

INSTALLATION

Parts and Specifications

	
<ol style="list-style-type: none">1. Control Panel2. Detergent Dispenser Drawer3. Drum4. Door5. Cover Cap6. Drain Pump Filter7. Drain Plug8. Levelling Feet	<ol style="list-style-type: none">1. Power Plug2. Transit Bolts3. Drain Hose

Accessories

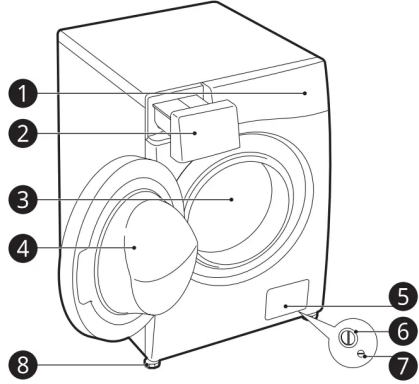
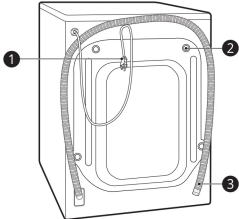
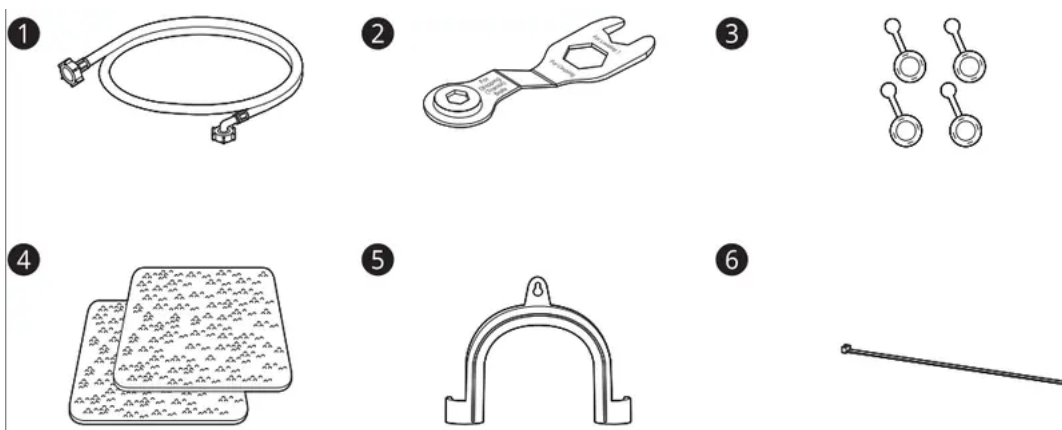

1. Cold Supply Hose (1 EA) (Option: Hot (1EA))
2. Spanner
3. Caps for Covering Transit Bolt Holes*
4. Anti-Slip Sheets*
5. Elbow Bracket for Securing Drain Hose*
6. Tie Strap*

Installation Place Requirements

- Install the appliance on a flat hard floor. (Allowable slope under the appliance: 1°)
- Never try to correct any unevenness in the floor with pieces of wood, cardboard or similar materials under the appliance.
- If it is impossible to avoid positioning the appliance next to a gas cooker or coal burning stove, an insulation (850 X 600 mm) covered with aluminum foil on the side facing the cooker or stove must be inserted between the two appliances.
- Ensure that when the appliance is installed, it is easily accessible for an engineer in the event of a breakdown.
- With the appliance installed, adjust all four feet using the transit bolt spanner provided to ensure the appliance is stable, and a clearance of approximately 5 mm is left between the top of the appliance and the underside of any worktop.
- Additional clearance should have 100 mm for the wall and 20 mm for rear, right and left side.

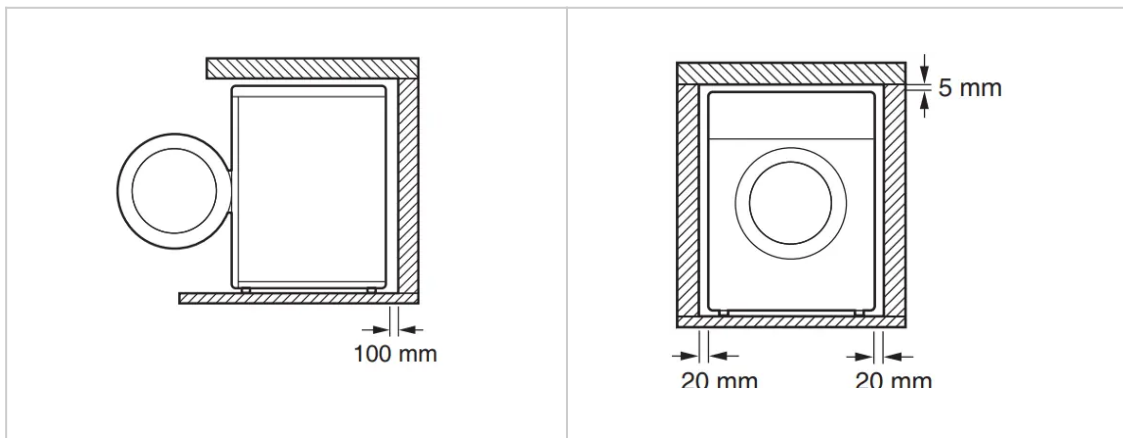

WARNING This appliance must only be used for domestic household purposes and should not be used in mobile applications.

NOTE If the appliance is installed on a raised platform, it must be securely fastened in order to eliminate the risk of falling off.

Wooden Floors (Suspended Floors)

When installing the appliance on wooden floors, use rubber cups to prevent the appliance from excessive vibration and unbalance.

- To prevent vibration, we recommend you to place rubber cups (1) at least 15 mm thick to each foot of the appliance, secured to at least two floor beams with screws.

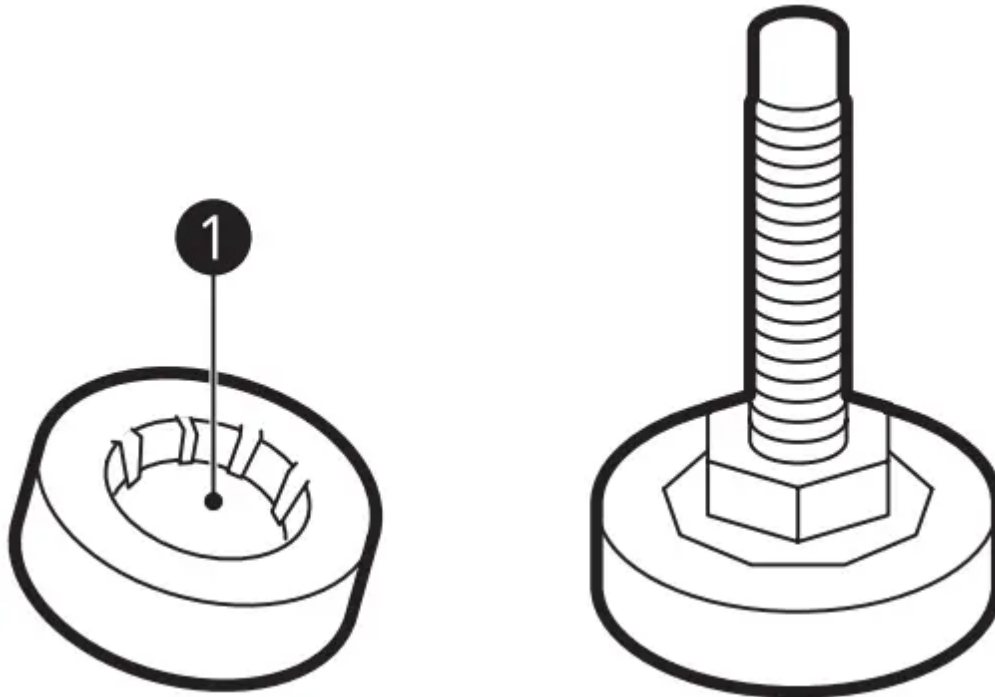

- If possible, install the appliance in one of the corners of the room, where the floor is more stable.
- Fit the rubber cups to reduce vibration.

Ventilation Make sure that air circulation around the appliance should not be impeded by carpets, rugs, etc.

Ambient Temperature

- Do not install the appliance in rooms where freezing temperatures may occur. Frozen hoses may burst under pressure. The reliability of the electronic control unit may be impaired at temperatures below freezing point.
- If the appliance is delivered in winter and temperatures are below freezing, place the appliance at room temperature for a few hours before putting it into operation.

Electrical Connection

- Do not use an extension cord or double adapter.
- Always unplug the appliance and turn off the water inlet after use.
- Connect the appliance to an earthed socket in accordance with current wiring regulations.

- The appliance must be positioned so that the plug is easily accessible.
- Repairs to the appliance must only be carried out by the qualified personnel. Repairs carried out by inexperienced persons may cause injury or serious malfunctioning. Contact your LG Electronics service centre.
- Power outlet must be at least 1 meter of either side of the location of the appliance.

WARNING The power plug must be plugged into an appropriate outlet socket that is installed and grounded in accordance with all local codes and ordinances.

Unpacking the Appliance

Lifting the Appliance Off the Foam Base

1. After removing the carton and shipping material, lift the appliance off the foam base. Make sure the tub support (1) comes off with the base and is not stuck to the bottom of the appliance.
2. If you must lay the appliance down to remove the carton base (2) always protect the side of the appliance and lay it carefully on its side. Do not lay the appliance on its front or back.

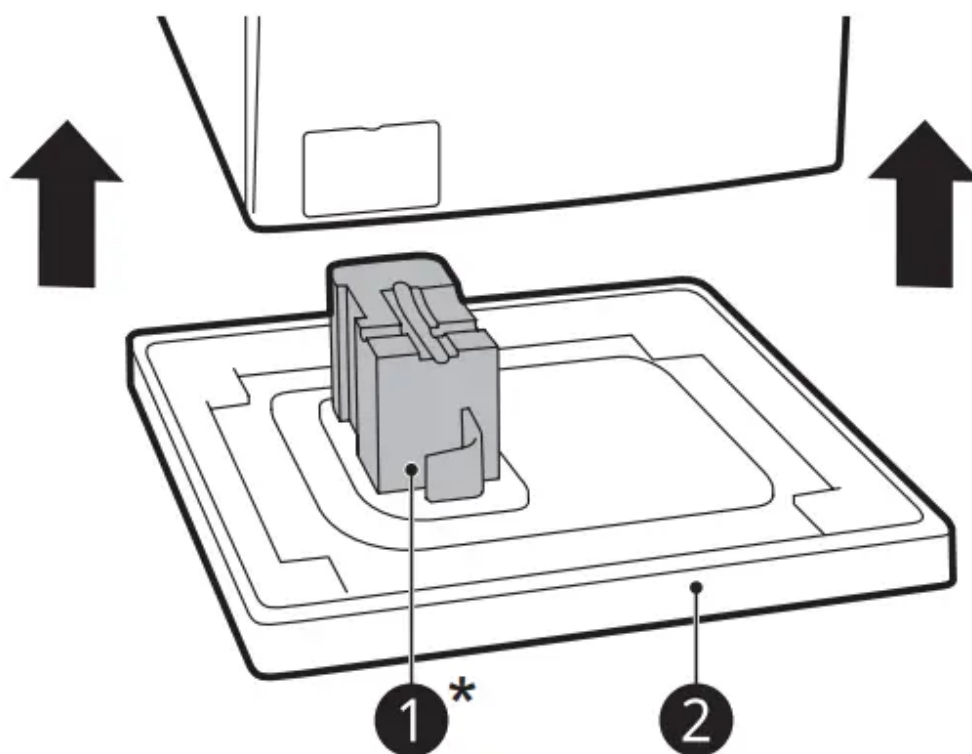

Removing the Bolt Assemblies

1. Starting with the bottom two transit bolts (1), use the spanner (included) to fully loosen all transit bolts by turning them counterclockwise.

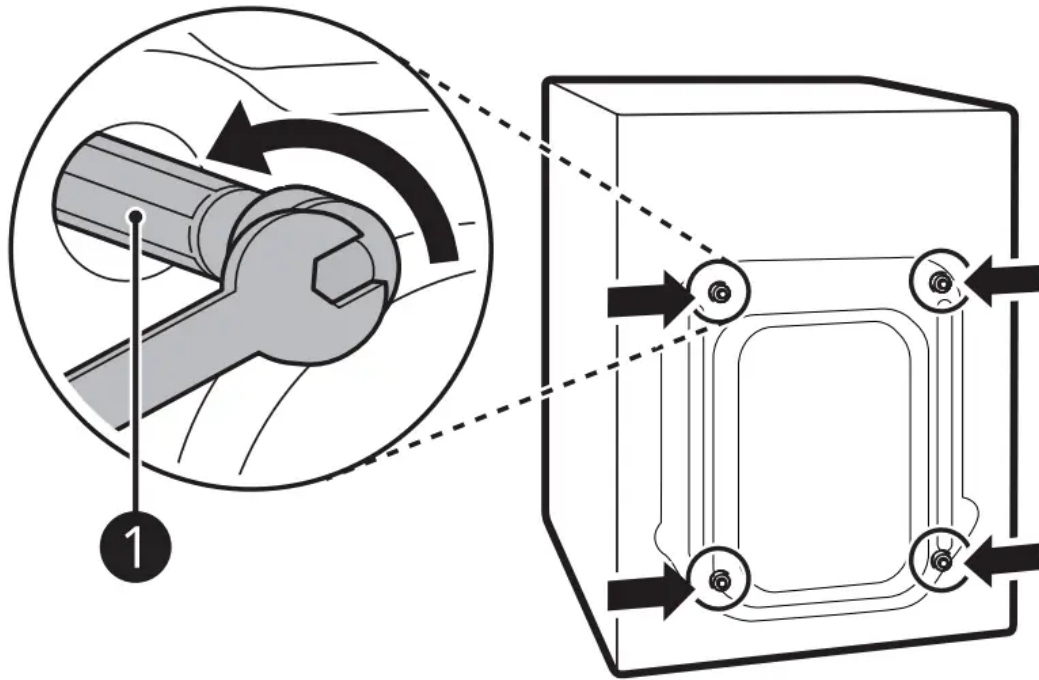

2. Remove the bolt assemblies by wiggling them slightly while pulling them out.

3. Install the hole caps. Locate the hole caps (2) included in the accessory pack or attached on the back.

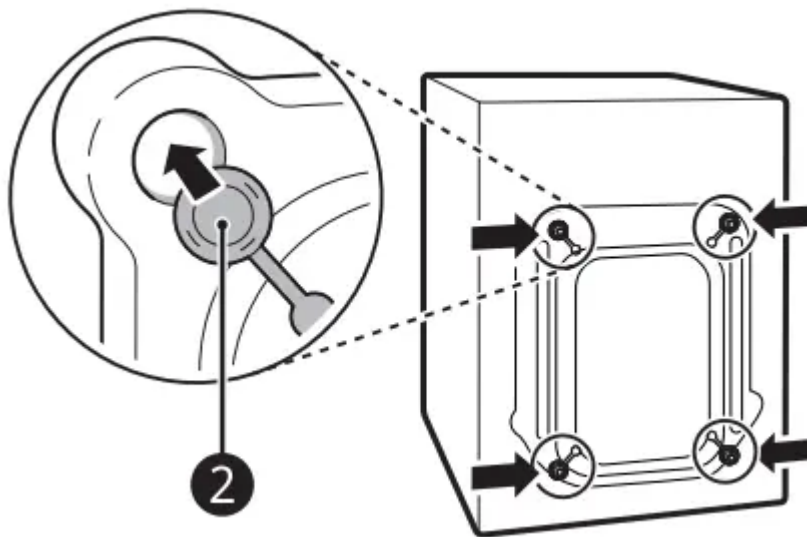

Leveling the Appliance

When pushing down the edges of the top plate diagonally, the appliance should not move up and down at all (check both directions). If the appliance rocks when pushing the top plate of the appliance diagonally, adjust the feet again.

NOTE Timber or suspended type flooring may contribute to excessive vibration and unbalance. Reinforcement or bracing of the timber floor may need to be considered to stop or reduce excessive

noise and vibration. Do not install the washer on any elevated surface, stand or plinth as it can become unstable and fall causing serious injury and damage.

Adjusting and Levelling the Feet

When installing the appliance, the appliance should be aligned and perfectly level. If the appliance is not aligned and level properly, the appliance may be damaged or may not operate properly.

1. Turn the levelling feet as required if the floor is uneven.

- Do not insert pieces of wood etc. under the feet.
- Make sure that all four feet should be stable and resting on the floor.

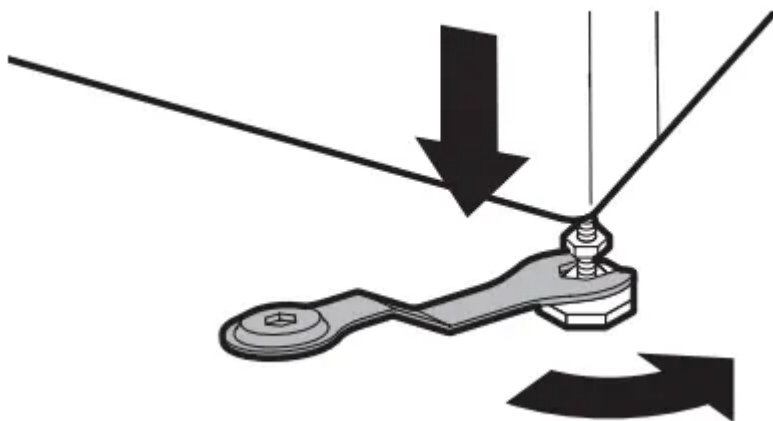
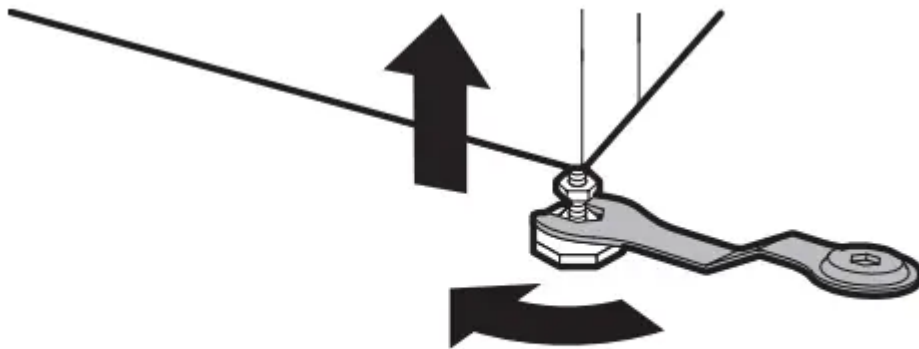

2. Check if the appliance is perfectly level using a spirit level (1)

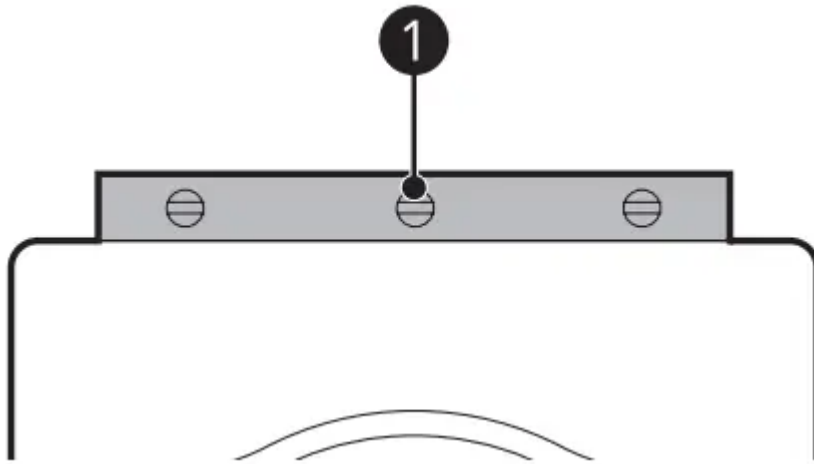

3. Secure the levelling feet with the lock nuts (2) by turning counterclockwise against the bottom of the appliance.

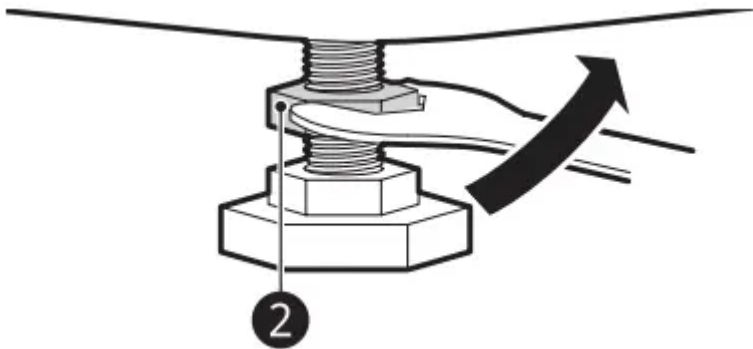

4. Check if all lock nuts at the bottom of the appliance are secured properly.

NOTE

- Proper placement and leveling of the appliance will ensure long, regular, and reliable operation.
- The appliance must be 100% horizontal and stand firmly in position.
- It must not 'Seesaw' across corners under the load.
- Do not let the feet of the appliance get wet. Failure to do so may cause vibration or noise.

Using Anti-Slip Sheets

This feature may vary depending on the models purchased.

If you install the appliance on a slippery surface, it may move because of excessive vibration. Incorrect leveling may cause malfunction through noise and vibration. If this occurs, install the anti-slip sheets under the leveling feet and adjust the level.

1. Clean the floor to attach the anti-slip sheets.
 - Use a dry rag to remove and clean foreign objects and moisture. If moisture remains, the anti-slip sheets may slip.
2. Adjust the level after placing the appliance in the installation area.
3. Place the adhesive side (1) of the anti-slip sheets on the floor.
 - The most effective way is to install the antislip sheets under the front feet. If it is difficult to place the sheets under the front feet of the appliance, attach them under the rear feet.

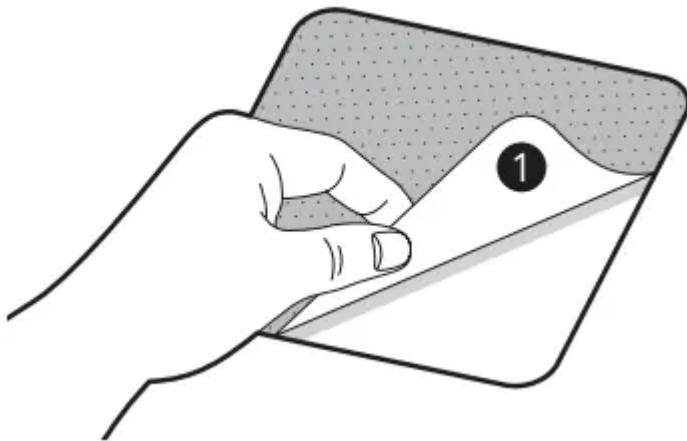

4. Put the appliance on the anti-slip sheets.
 - Do not attach the adhesive side (1) of anti-slip sheets to the feet of the appliance.

Connecting the Water Inlet Hose

- Water pressure must be between 100 kPa and 800 kPa (1.0 – 8.0 kgf/cm²). If the water pressure is more than 800 kPa, a decompression device should be installed.
- Do not overtighten the water inlet hose to all valves.
- Periodically check the condition of the hose and replace the hose if necessary.

Checking the Rubber Seal on the Water Inlet Hose

Two rubber seals (1) are supplied with the water inlet hoses. They are used for preventing water leaks. Ensure the washers are in place before connecting the inlet hose. Make sure the connection to taps is sufficiently tight. Do not use any mechanical device to overtighten the inlet hoses. Hand tighten only with the aid of a soft cloth if necessary. After both ends have been connected, open the taps slowly and check for leaks. The curved end of the inlet hose must be connected to the machine.

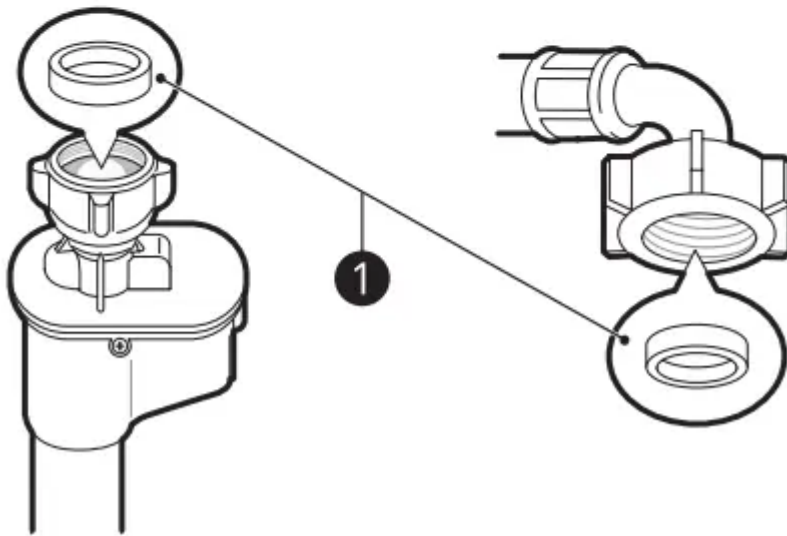
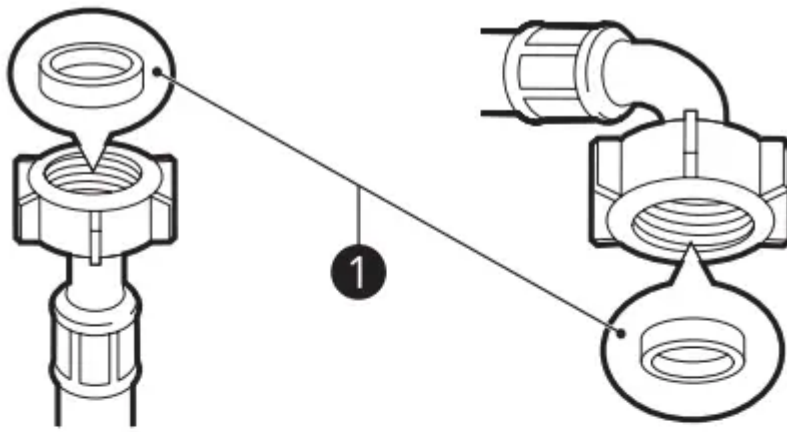

Connecting Hose to Water Tap (Each country's methods of connection will vary. Refer to the appropriate type below)

Connecting Screw-Type Hose to a Tap with a Thread

Screw the hose connection to a water supply tap, which has a $\frac{3}{4}$ " threaded union. Use the straight end of the hose to connect to the tap. Connect the curved end of the hose to the machine.



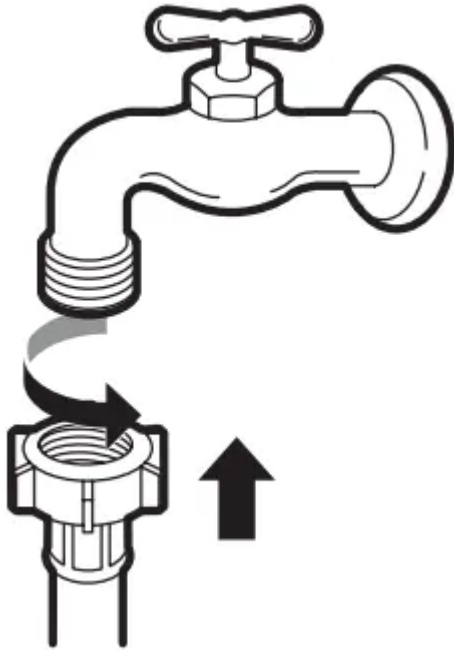

NOTE Before connecting the inlet hose to the water tap, turn on the water tap to flush out foreign substances (dirt, sand, sawdust, and etc.) in the water lines. Let the water drain into a bucket, and check the water temperature.

Connecting Screw-Type Hose to Tap Without Thread

1. Unscrew the adapter ring plate and loose the four fixing screws	
2. Remove the guide plate if the tap is too large to fit the adapter.	
3. Push the adapter onto the end of the tap so that the rubber seal forms a watertight connection. Tighten the four fixing screws and the adapter ring plate.	
4. Pull the connector latch plate down, push the supply hose onto the adapter, and release the connector latch plate. Make sure the adapter locks into place	

NOTE After connecting the supply hose to the water tap, turn on the water tap to flush out foreign substances (dirt, sand, sawdust, and etc.) in the water lines. Let the water drain into a bucket, and check the water temperature.

Connecting the Hose to the Appliance

Screw the water line to the water supply on the back of the appliance.



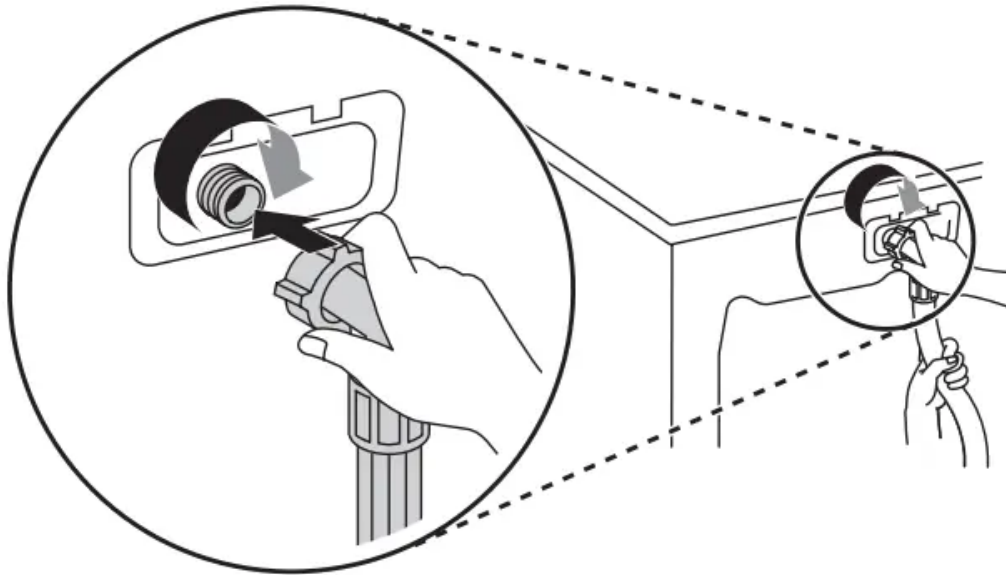

NOTE

- After completing connection, if water leaks from the hose, repeat the same steps. Use the most conventional type of tap for the water supply. If the tap is square or too big, remove the guide plate before inserting the tap into the adaptor.
- Make sure that the hose should not be kinked or trapped.

Installing the Drain Hose

Installing the Drain Hose with the Elbow Bracket

The drain hose should not be placed higher than 100 cm above the floor. Water in the appliance may not drain or may drain slowly.

- Securing the drain hose correctly will protect the floor from damage due to water leakage.

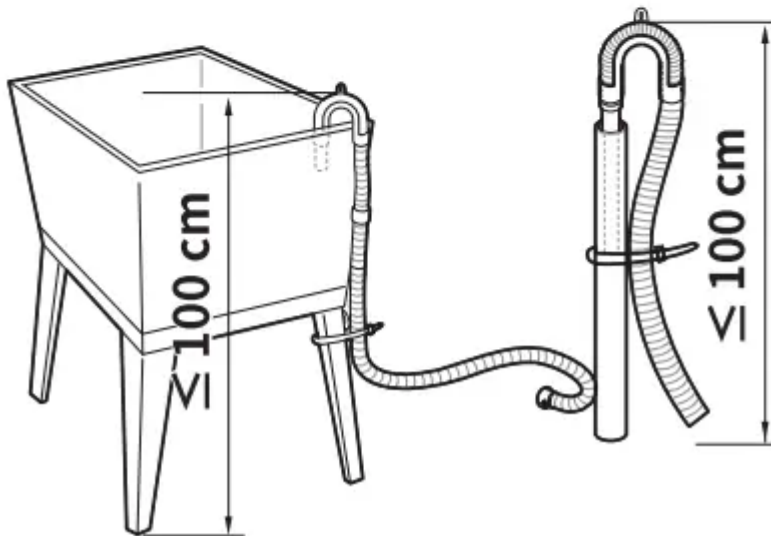
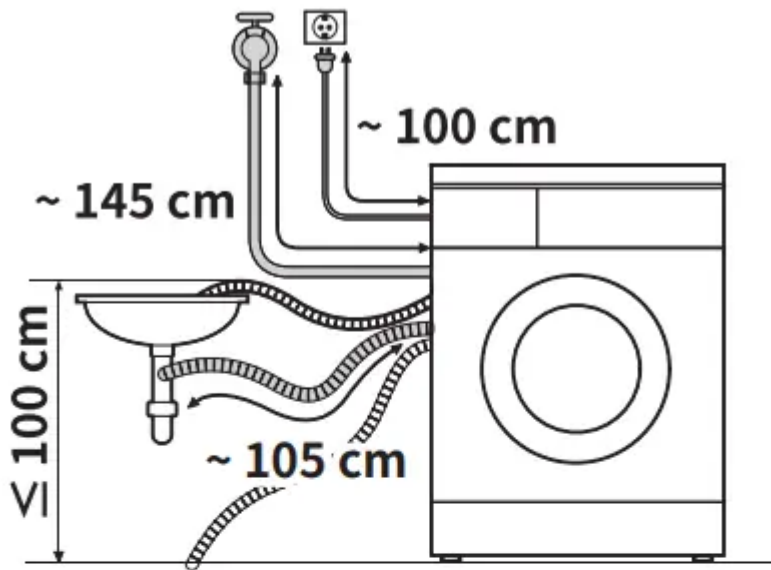

- If the drain hose is too long, do not force it back into the appliance. This will cause abnormal noise.
- When installing the drain hose to a sink, secure it tightly with string.

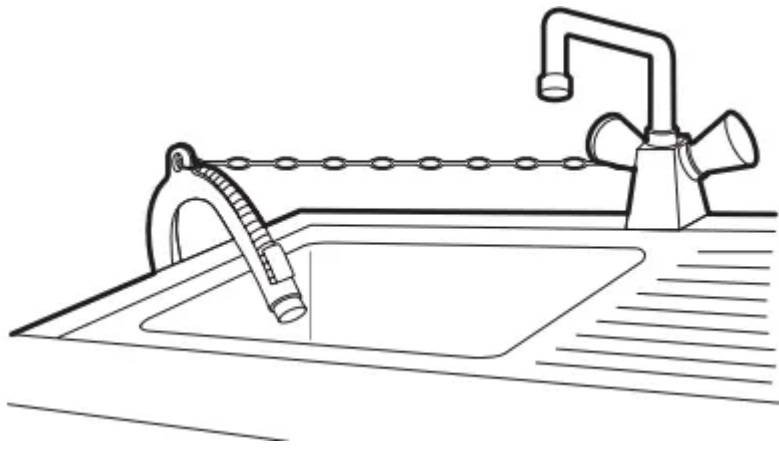

OPERATION

Operation Overview

<p>1. Sort laundry and load items.</p> <ul style="list-style-type: none">• Sort laundry by fabric type, soil level, colour and load size as needed. Open the door and load items into the appliance.
<p>2. Add detergent or softener</p> <ul style="list-style-type: none">• Add the proper amount of detergent to the detergent dispenser drawer. If desired, add bleach or fabric softener to the appropriate areas of the dispenser.
<p>3 Turn on the appliance.</p> <ul style="list-style-type: none">• Press the Power button to turn on the appliance.
<p>4. Choose the desired cycle.</p> <ul style="list-style-type: none">• Press the cycle button repeatedly or turn the cycle selector knob until the desired cycle is selected.• Now select a wash temperature and spin speed. Pay attention to the care labeling of your clothes
<p>5 Begin cycle.</p> <ul style="list-style-type: none">• Press the Start/Pause button to begin the cycle. The appliance will agitate briefly without water to measure the weight of the load. If the Start/Pause button is not pressed within 15 minutes, the appliance will shut off and all settings will be lost.
<p>6 End of cycle.</p> <ul style="list-style-type: none">• When the cycle is finished, a melody will sound. Immediately remove your clothing from the appliance to reduce wrinkling. Check around the door seal when removing the load for small items that may be caught in the seal.

Preparing the Wash Load

Sorting the Clothes

- For best washing results, sort your clothes according to the care label stating fabric type and washing temperature. Adjust the spin speed or spin intensity in accordance with the fabric type.
- Soil level (Heavy, Normal, Light):
- Separate clothes according to soil level. If possible, do not wash heavily soiled items with lightly soiled ones.
- Colour (White, Lights, Dark): Wash dark or dyed clothes separately from whites or light colours. Mixing dyed clothes with light clothes can result in dye transfer or discolouration of lighter clothes.
- Lint (Lint producers, Collectors): Wash separately lint producing fabrics from lint collecting fabrics. Lint producers can result in pilling and linting on the lint collectors.

Checking the Clothes Care Label

The symbols tell you about the fabric content of your garment and how it should be washed.

NOTE

The dashes under the symbol give you information about the type of fabric and the maximum allowance of mechanical stress.

Checking the Clothes before Loading

- Combine large and small items in a load. Load large items first.
- Large items should not be more than half of the total wash load. Do not wash single items. This may cause an unbalanced load. Add one or two similar items.
- Check all pockets to make sure that they are empty. Items such as nails, hair clips, matches, pens, coins and keys can damage both your appliance and clothes.
- Wash delicates (stockings, underwired bras) in a wash net.
- Close zippers, hooks and strings to make sure that these items do not snag on other clothes.
- Pre-treat dirt and stains by brushing a small amount of detergent dissolved water onto stains to help lift dirt.

Adding Detergents and Softeners

Detergent Dosage



- Detergent should be used according to the instruction of the detergent manufacturer and selected according to type, colour, soiling of the fabric and the washing temperature. Use only detergents that are suitable for Drum (front load) type washers.

- If too many suds occur, reduce the detergent amount.
- If too much detergent is used, too many suds can occur and this will result in poor washing results or cause heavy load to the motor.
- If you wish to use liquid detergent, follow the guidelines provided by the detergent manufacturer.
- You can pour liquid detergent directly into the main detergent drawer if you are starting the wash cycle immediately.
- Do not use liquid detergent if you are using
- Delay End function, or if you have selected
- Pre Wash option, as the liquid will dispense immediately and may harden in the drawer or the tub.
- Detergent usage may need to be adjusted for water temperature, water hardness, size and soil level of the load. For best results, avoid oversudsing.
- Refer to the label of the clothes, before choosing the detergent and water temperature.
- Use only suitable detergents for the respective type of clothing:
 - Liquid detergent is often designed for special applications, e.g. for coloured fabric, wool, delicate or dark laundry.
 - Powdered detergent is suitable for all types of fabric.
 - For better washing results of white and pale garments, use powdered detergent with bleach.
 - Detergent is flushed from the dispenser at the beginning of the wash cycle.

NOTE

- Do not let the detergent harden. Doing so may lead to blockages, poor rinse performance or odour.
- Full load: According to manufacturer's recommendation or less.
- Part load: ½ of the normal amount
- Minimum load: ⅓ of full load

Adding Detergent

- Detergent for main wash (1) only => 
- Detergent for pre-wash (2) and main wash (1) =>  

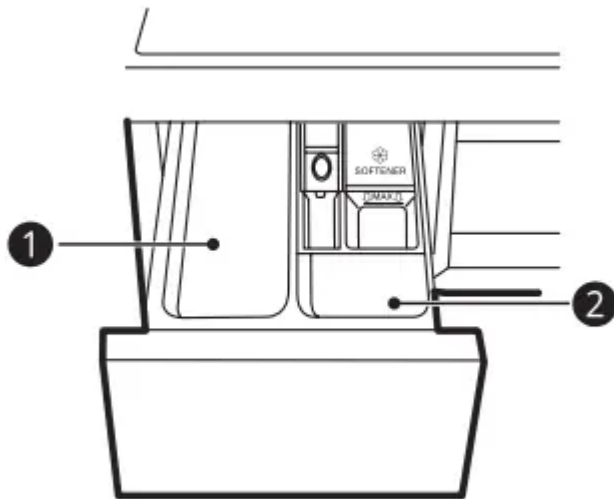

NOTE

- Use the appropriate amount of detergent. Too much detergent, bleach or softener may cause an overflow.
- When selecting Pre Wash on a full load, divide the dosage into $\frac{1}{3}$ for pre wash and $\frac{2}{3}$ for main wash.

Adding Detergent Tablet

Detergent tablets can also be used when washing as an alternative to powder or liquid.

1. Open the door and put detergent tablets into the drum.

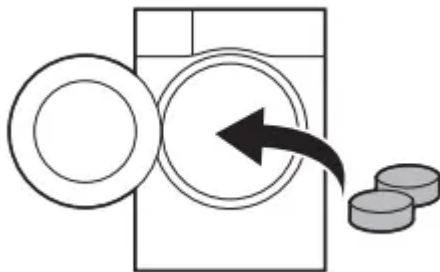

2. Load the clothes into the drum and close the door.

NOTE Do not put tablets into the drawer

Adding Fabric Softener

- Do not exceed the maximum fill line. Overfilling can cause early dispensing of the fabric softener, which may stain clothes. Close the dispenser drawer slowly.



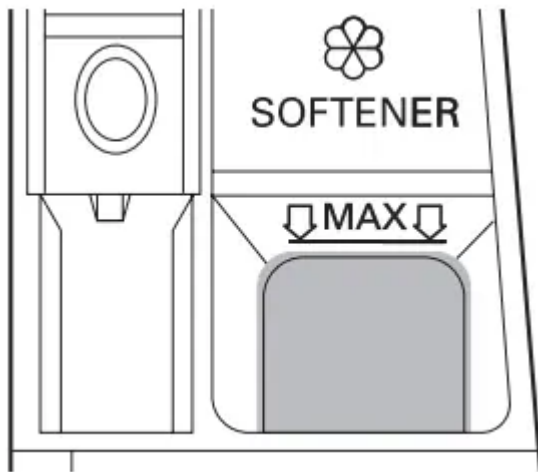

- Do not leave the fabric softener in the detergent drawer for more than 1 day (Fabric softener may harden).
- Softener will automatically be added during the last rinse cycle.
- Do not open the drawer when water is being supplied.
- Solvents (e.g. benzene, etc.) must not be used.

NOTE

- Do not pour fabric softener directly onto the garments, as this may cause stains on your clothing.

Adding Water Softener

A water softener, such as anti-limescale can be used to cut down on the use of detergent in areas with high water hardness level.

- First add detergent, and then the water softener. Dispense according to the amount specified on the packaging.

Control Panel

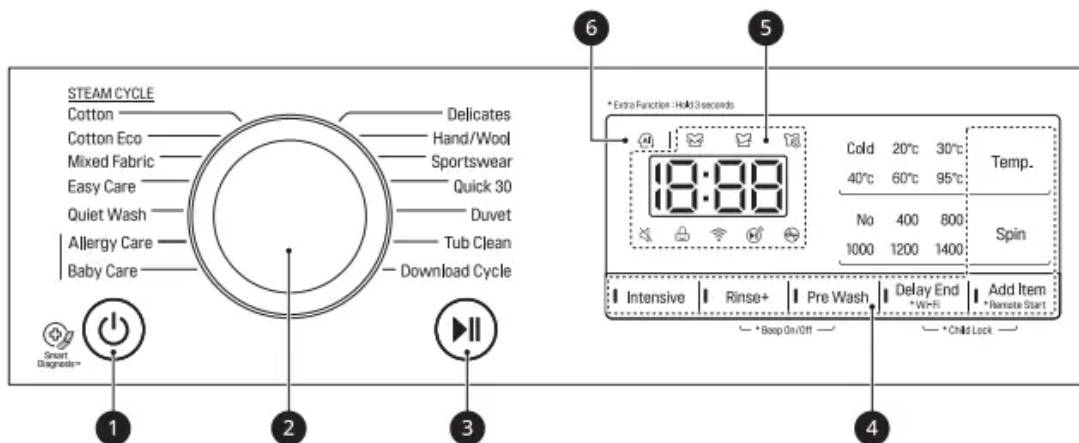

1. Power Button

Press the Power button to turn on or off the appliance. (2) Programme Knob

2. Programmes are available according to the laundry type.

The lamp will light up to indicate the selected programme.

3. Start/Pause Button

This Start/Pause button is used to start the wash cycle or pause the wash cycle.

If a temporary stop of the wash cycle is needed, press the Start/Pause button.

4. Extra Options and Functions

- Extra options and functions are available for better washing performance. Several options and functions can be customized.
- To use the extra functions, press and hold the corresponding button for 3 seconds. The corresponding symbol lights up in the display.
- In order to use the Remote Start function, refer to SMART FUNCTIONS.
- This allows you to select an additional programmes and will light when selected.



: When this icon is illuminated, the beep sound is off simultaneously.





: When this icon is illuminated, the control panel is locked except for the power button.



: This icon is illuminated when the appliance is connected to WLAN network.

5. Display

6. AI DD

-  AI DD provides automatic load sensing that determines the best wash action.
-  is activated when Cotton, Mixed Fabric and Easy Care programmes are selected and operates when these selected programmes are in operation.

Extra Options and Functions

Intensive

1. You can use this option to wash heavily soiled laundry.
Press the Power button.
2. Select a washing programme.
3. Press the Intensive button.
4. Press the Start/Pause button.

Rinse

You can select an additional Rinse by pressing the Rinse+ button. This option is recommended for people with detergent allergies.

Rinse+

This option is used to add an additional rinse to the wash cycle.

Pre Wash

This option is recommended when washing a heavily soiled load.

1. Press the Power button.
2. Select a washing programme.
3. Press the Pre Wash button.
4. Press the Start/Pause button

Delay End

You can set this function so that the appliance starts automatically and finishes after a specified time interval.

1. Press the Power button.
2. Select a washing programme.
3. Press the Delay End button to set a required time.
4. Press the Start/Pause button.

NOTE

- The delay time is the time to the end of the programme, not the start. The actual running time may vary due to water temperature, wash load and other factors.
- To cancel the function, the Power button should be pressed.
- Avoid using liquid detergent for this function.

CAUTION

- When adding the laundry, ensure the load is completely within the drum before closing the door. If the laundry is caught in the door seal or door latch, the door gasket may get damaged. It may cause water leakage and malfunctions.
- Forcing the door open will cause damage to parts and create safety hazards.
- If you open the door of drum whilst there is excessive sudsing, water may leak and cause damage to the flooring.

Wi-Fi

When WLAN is connected, the Wi-Fi icon on the control panel is lit.

Add Item

You can use this option in order to add or remove the laundry after the washing programme has started.

1. Press the Add Item button when the LED is turned on. If the LED is not illuminated, the Add item opportunity time has expired and the function will not operate.
2. Open the door after it unlocks itself.
3. Add or remove laundry.
4. Close the door and press the Start/Pause button.

NOTE For safety reasons, the door remains locked when the water level or temperature inside of the drum is high. It is not possible to add laundry at this time.

Temp.

You can use this option to select the wash temperature for the selected programme. Press this button until the desired setting is lit. Not all temperatures will be available in certain cycles. All rinses are in cold water.

- Select the water temperature suitable for the type of load you are washing. Follow the garment fabric care labels for best results.



Spin speed can be selected by pressing the Spin button repeatedly.

1. Press the Power button.
2. Select a washing programme.
3. Press the Spin button to select the appropriate spin speed.
4. Press the Start/Pause button.

NOTE When you select No, the tub will still rotate for a short time to drain quickly



This function can only be selected when the appliance is in operation and a wash is in progress.

- Press and hold the Rinse+ and Pre Wash button simultaneously for 3 seconds to set the this function.

NOTE

- Once this function is set, the setting is memorized even after the power is turned off.
- If you want to turn the beeper off, simply repeat this process.



Use this function to disable the controls. This function can prevent children from changing cycles or operating the appliance.

Locking the Control Panel

1. Press and hold the Delay End and Add Item button for 3 seconds.
2. A beeper will sound, and CL will appear on the display. When the Child Lock is set, all buttons are locked except for the Power button.

NOTE Turning off the power will not reset this function. You must deactivate this function before you can access any other functions.

Unlocking the Control Panel

Press and hold the Delay End and Add Item button for 3 seconds.

SMART FUNCTIONS

Using LG SmartThinQ Application



This feature is only available on the model with SmartThinQ or **SmartThinQ** logo

1. Check the distance between the appliance and the wireless router (Wi-Fi network).
 - If the distance between the appliance and the wireless router is too far, the signal strength becomes weak. It may take a long time to register or installation may fail.
2. Turn off the Mobile data or Cellular Data on your smartphone.
 - For iPhones, turn data off by going to Settings → Cellular → Cellular Data.

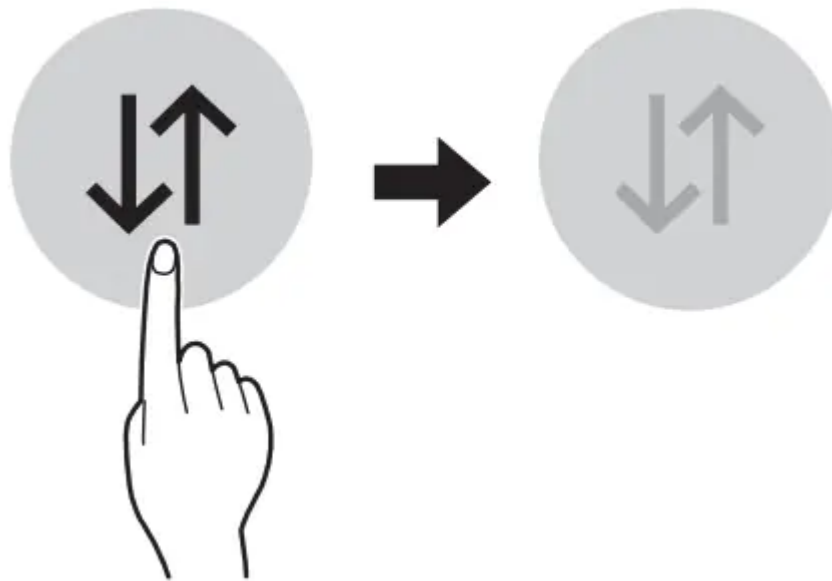

3. Connect your smartphone to the wireless router.

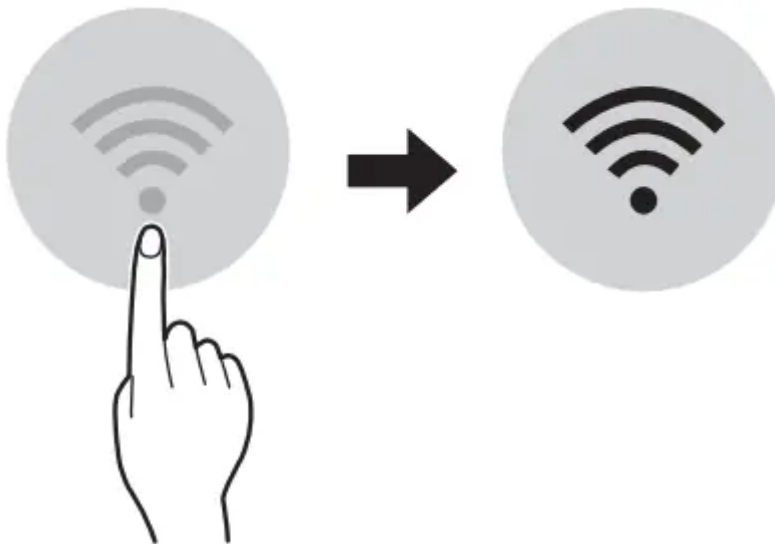

NOTE

- To verify the Wi-Fi connection, check that Wi-Fi  icon on the control panel is lit.
- The appliance supports 2.4 GHz Wi-Fi networks only. To check your network frequency, contact your Internet service provider or refer to your wireless router manual.
- LG SmartThinQ is not responsible for any network connection problems or any faults, malfunctions, or errors caused by network connection.
- If the appliance is having trouble connecting to the Wi-Fi network, it may be too far from the router.
- Purchase a Wi-Fi repeater (range extender) to improve the Wi-Fi signal strength.
- The Wi-Fi connection may not connect or may be interrupted because of the home network environment.

- The network connection may not work properly depending on the Internet service provider.
- The surrounding wireless environment can make the wireless network service run slowly.
- The appliance cannot be registered due to problems with the wireless signal transmission.
- Unplug the appliance and wait about a minute before trying again.
- If the firewall on your wireless router is enabled, disable the firewall or add an exception to it.
- The wireless network name (SSID) should be a combination of English letters and numbers. (Do not use special characters.)
- Smartphone user interface (UI) may vary depending on the mobile operating system (OS) and the manufacturer.
- If the security protocol of the router is set to WEP, you may fail to set up the network. Please change it to other security protocols (WPA2 is recommended) and register the product again.

Installing LG SmartThinQ

Search for the LG SmartThinQ application from the Google Play Store or Apple App Store on a smart phone. Follow instructions to download and install the application.

Smart Diagnosis

Use this function if you need an accurate diagnosis by an LG Electronics customer information centre when the appliance malfunctions or fails. Use this function only to contact the service representative, not during the normal operation.

1. Press the Power button to turn on the appliance. Do not press any other buttons
2. When instructed to do so by the call centre, place the mouthpiece of your phone close to the Smart Diagnosis icon.

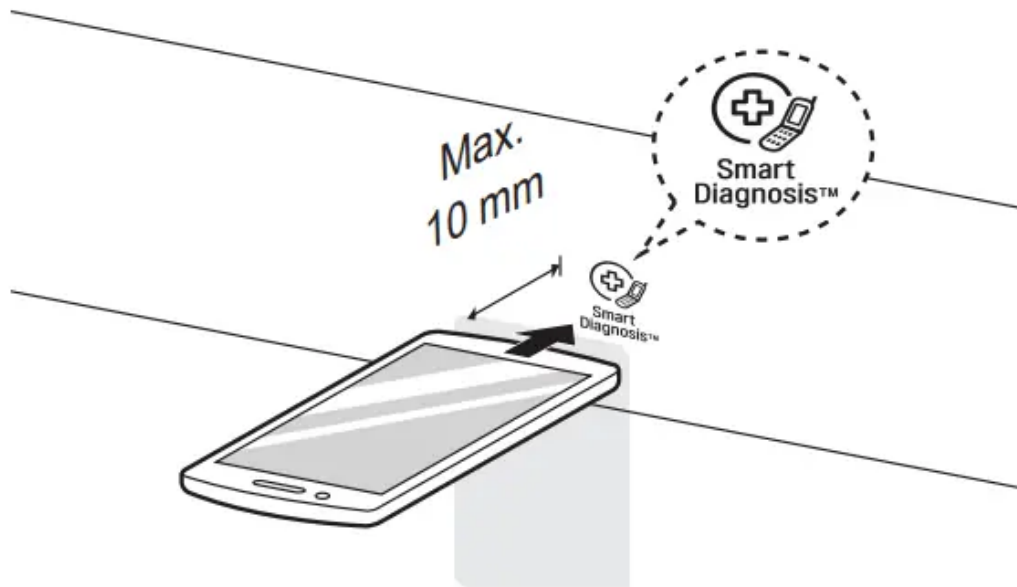

3. Press and hold the Temp. button for 3 seconds. for data transfer is displayed.
4. Keep the phone in place until the tone transmission has finished. Time remaining for data transfer is displayed.
 - For best results, do not move the phone while the tones are being transmitted.
 - If the call centre agent is not able to get an accurate recording of the data, you may be asked to try again.
5. Once the countdown is over and the tones have stopped, resume your conversation with the call centre agent, who will then be able to assist you using the information transmitted for analysis.

NOTE

- This function depends on the local call quality.
- The communication performance will improve and you can receive better service if you use the home phone.
- If the data transfer is poor due to poor call quality, you may not receive the best diagnosis service.

MAINTENANCE

Cleaning After Every Wash

Care After Wash

- After the wash cycle is finished, wipe the door and door seal to remove any moisture.
- Leave the door slightly open to dry the drum.
- Wipe the appliance with a dry cloth to remove any moisture

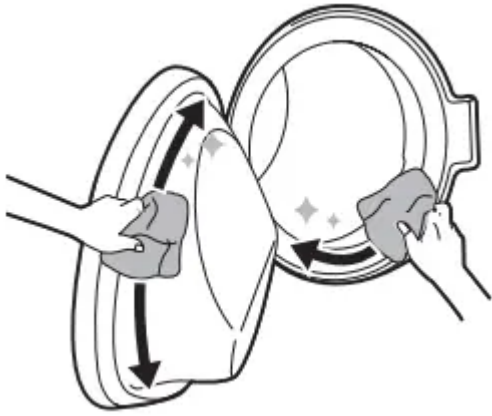

Cleaning the Exterior

Exterior

Immediately wipe off any spills. Wipe with a damp cloth.

WARNING Do not attempt to separate any panels or disassemble the appliance. Do not apply any sharp objects to the control panel in order to operate the appliance.

Door

- Wash with a damp cloth on the outside and inside and then dry with a soft cloth.

WARNING

Do not attempt to separate any panels or disassemble the appliance. Do not apply any sharp objects to the control panel in order to operate the appliance.

Cleaning the Interior

- Use a towel or soft cloth to wipe around the door opening and door glass.
- Always remove items from the appliance as soon as the cycle is complete. Leaving damp items in the appliance can cause wrinkling, colour transfer, and odour.

Cleaning the Appliance Periodically

Tub Clean

This function is used to clean inside of the appliance.

A higher water level is used in this programme at higher spin speed. Run this function once a month (or more often if needed) to remove detergent buildup and other residue.

1. Remove any clothing or items from the appliance and close the door
2. Open the dispenser drawer and add anti-limescale powder to the main wash compartment.
 - Tablets can be placed directly into the drum as an alternative to powder.
3. Close the dispenser drawer slowly.

4. Turn on the power, and then select the Tub Clean

- **tcl** will be displayed on the display

5. Press the Start/Pause button to start.

6. After the programme is complete, leave the door open to dry the door opening, gasket, and door glass.

CAUTION

Leave the door open to dry inside of the appliance only if the children are supervised at home.

Cleaning the Water Inlet Filter

The water inlet filter collects lime or any sediment that may be in water that is supplied to the appliance. Clean the inlet filter every six months or so, or more often if the water is very hard or contains traces of limescale.

1. Turn off the water tap and unscrew the water inlet hose.

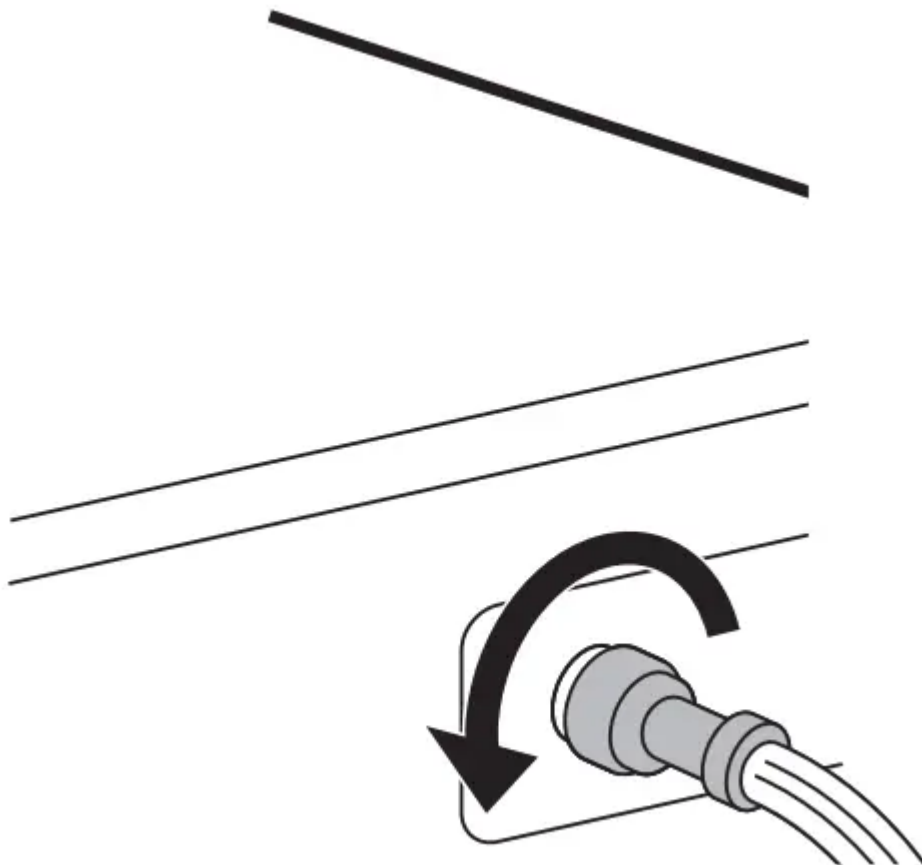

2. Remove the water inlet filter with small pliers and then clean the filter using a medium bristle tooth brush.

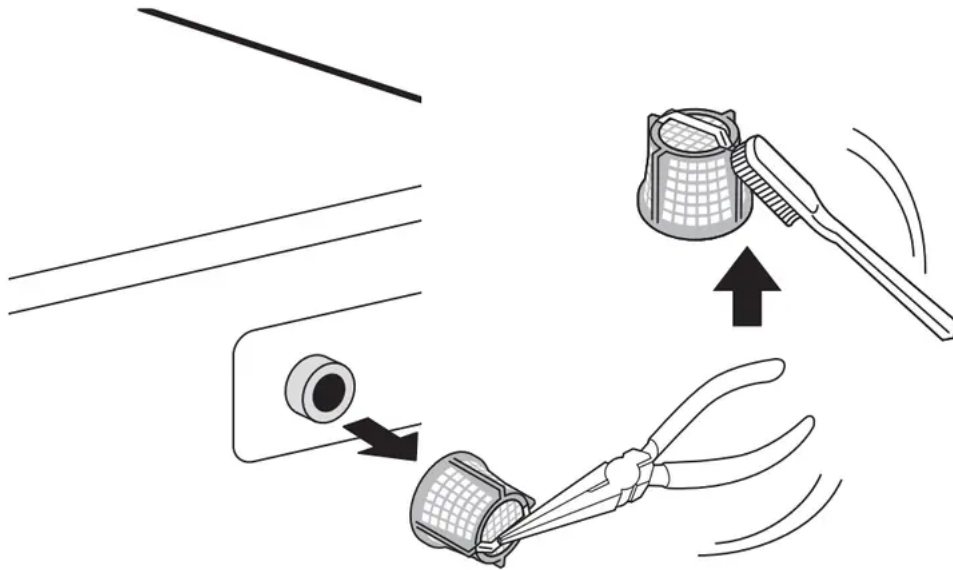

NOTE

- Turn off the supply tap to the appliance if the appliance is to be left for a certain period of time (e.g. holiday), especially if there is no floor drain (gully) in the immediate vicinity.
- **IE** will be displayed on the control panel when the water is not entering the detergent drawer.

Cleaning the Drain Pump Filter and Performing an Emergency Water Evacuation

The drain filter collects threads and small objects that may have been accidentally left in the clothes. Make sure that the filter is clean every six months to ensure smooth running of your appliance.

Allow the water to cool before cleaning the drain pump filter. Open the door in an emergency or perform an emergency water evacuation.

1. Unplug the appliance.
2. Open the cover cap and pull out the drain tube.

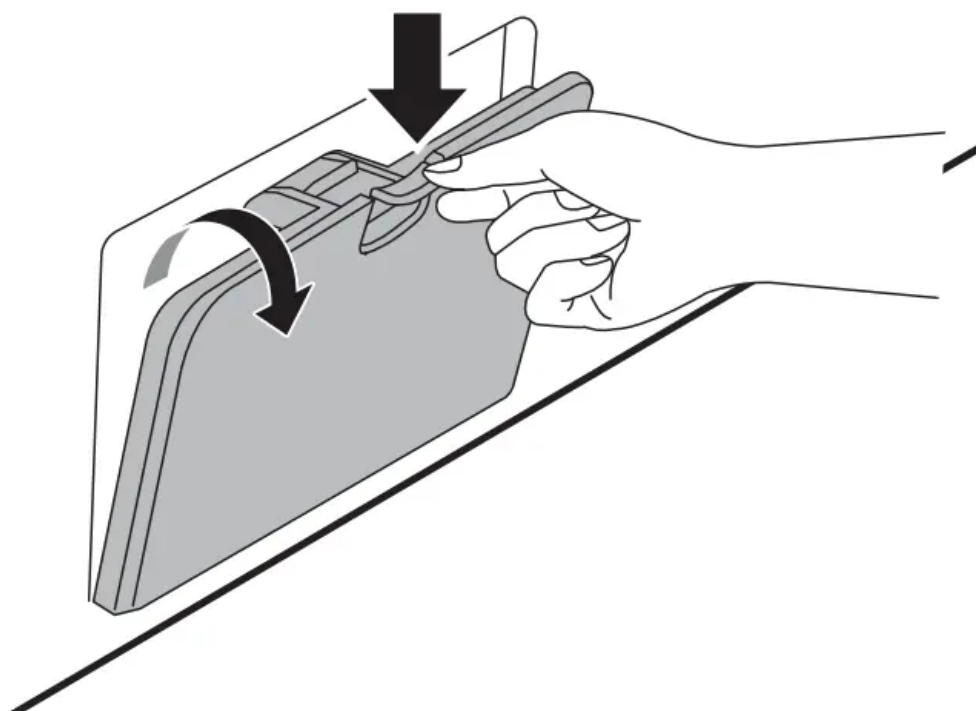

3. Remove the drain plug from the drain tube first (1), and then drain the water. Then slowly unscrew the drain pump filter (2) to drain the remaining water and then proceed to remove any debris or objects from the filter.

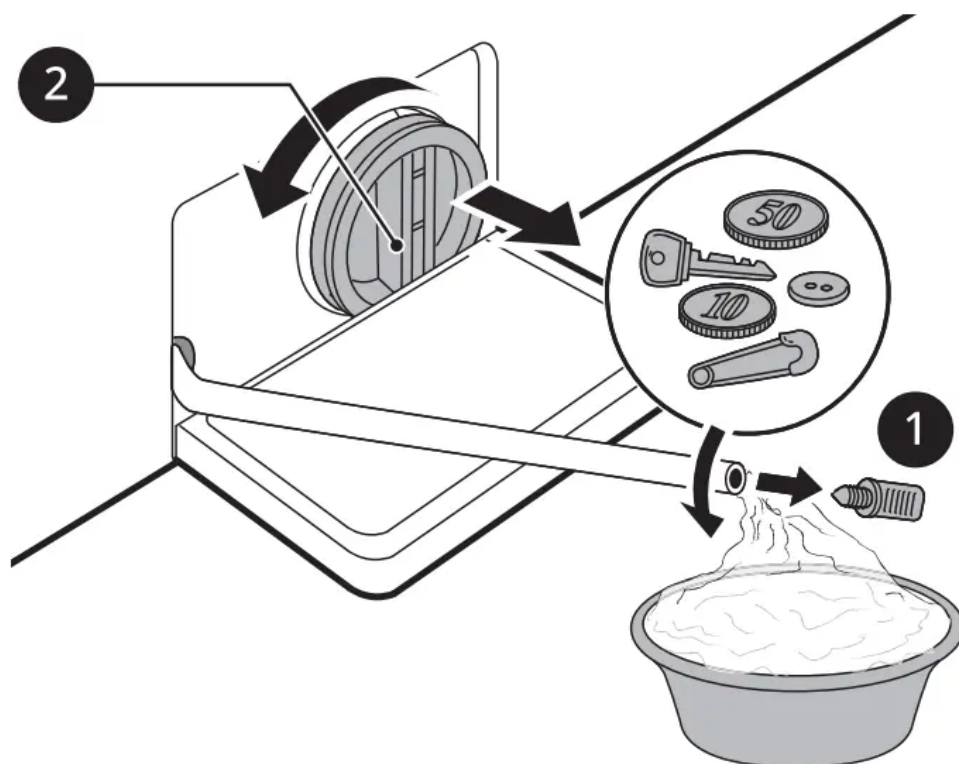

4. After cleaning the drain pump filter, carefully reinsert the filter and screw the drain cap back in clockwise carefully to avoid cross-threading and leakage. Reinsert the plug back into the drain tube and place the tube into its holder.

5. Close the cover cap.

CAUTION

- Be careful when draining, as the water may be hot.
- Run the drum cleaning programme once a month (or more often, as needed) to remove excess detergent and other debris.

Cleaning the Dispenser Drawer

Detergent and fabric softener can build up in the dispenser drawer. Liquid detergents can remain under the dispenser drawer and not dispense completely. Remove the drawer and inserts and check for build-up of cleaning products once or twice a month.

1. Remove the detergent dispenser drawer by pulling the drawer straight out until the drawer stops.

- Then gently pull the drawer outward while pressing hard the disengage button.

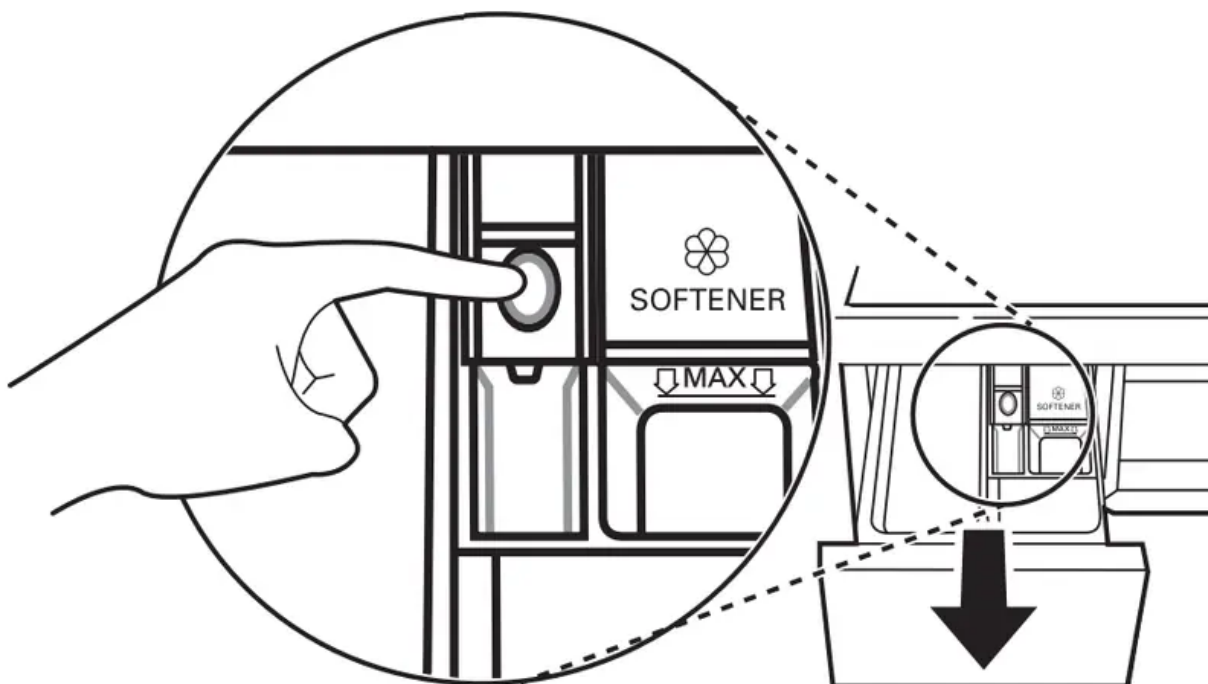

2. Remove the build-up of detergent and softener.

- Rinse the drawer and the components of the drawer with warm water to remove the build-up from detergent and softener. Use only water to clean the dispenser drawer. Dry the drawer and the components of the drawer with a soft cloth or towel.







3. To clean the drawer opening, use a cloth or small, non-metal brush to clean the recess.
 - Remove all residue from the upper and lower parts of the recess.
4. Wipe any moisture off the recess with a soft cloth or towel.
5. Reassemble the components of the drawer to the proper compartments and insert the drawer.

TROUBLESHOOTING



Symptoms	Possible Cause & Solution
IE INLET ERROR	<p>Water supply is not adequate in that location. Water does not enter appliance or it enters slowly.</p> <ul style="list-style-type: none"> • Check another tap in the house. <p>Water supply tap is not completely open. Water does not enter the appliance or it enters slowly.</p> <ul style="list-style-type: none"> • Open fully tap. <p>Water supply hose(s) are kinked.</p> <ul style="list-style-type: none"> • Straighten hose or reinstall the water inlet hose The filter of the supply hose(s) are clogged. • Check and clean the filter of the inlet hose. <p>If water leakage occurs in the aqua stop supply hose, indicator will become red.</p> <ul style="list-style-type: none"> • Replace the aqua stop supply hose.
UE UNBALANCE ERROR	<p>The appliance has a system which detects and corrects the unbalance of the appliance.</p> <ul style="list-style-type: none"> • The laundry may be too wet at the end of the cycle, rearrange the load to allow proper spinning. Close the door and press Start/Pause button. It may take a few moments before the appliance begins to spin. The door must be locked before spin can be achieved. <p>Load is too small. This system may stop spinning or even interrupt the spin cycle altogether if individual heavy articles (e.g. bath mat, bath robe, etc.) are loaded.</p> <ul style="list-style-type: none"> • Add 1 or 2 similar items or smaller articles of laundry to help balance the load. Close the door and press Start/Pause button. It may take a few moments before the appliance begins to spin. The door must be locked before spin can be achieved.
OE WATER OUTLET ERROR	<p>Drain hose is kinked or clogged. Water in the appliance does not drain or drains slowly.</p> <ul style="list-style-type: none"> • Clean and straighten the drain hose. <hr/> <p>The drain filter is clogged.</p>



Symptoms	Possible Cause & Solution
	<ul style="list-style-type: none"> • Check and clean the drain filter.
 DOOR ERROR	Door sensor malfunctions. <ul style="list-style-type: none"> • Please call LG service centre. You can find your local LG service centre phone number in the warranty card.
 CONTROL ERROR	This is a control error. <ul style="list-style-type: none"> • Unplug the power plug and call for service.
 MOTOR LOCKED ERROR	Over load in motor. <ul style="list-style-type: none"> • Let the appliance wait for 30 minutes until the motor is cooled down and then, restart the cycle.
 OVERFLOW ERROR	Water overfills due to the faulty water valve <ul style="list-style-type: none"> • Close the water tap. • Unplug the power plug. • Call for service.
 PRESSURE SENSOR ERROR	Water level sensor malfunctions. <ul style="list-style-type: none"> • Close the water tap. • Unplug the power plug. • Call for service.
 VIBRATION SENSOR ERROR	Vibration sensor malfunctions. <ul style="list-style-type: none"> • Call for service.
 FROZEN FAILURE	Is supply/drain hose or drain pump frozen? <ul style="list-style-type: none"> • Supply warm water into the drum in order to unfreeze the drain hose and the drain pump. Cover the supply hose with wet and warm towel.

Symptoms	Possible Cause & Solution
AE WATER LEAKAGE	Water leaks. <ul style="list-style-type: none"> • Call for service.
PF POWER FAILURE	The appliance experienced a mains power failure. <ul style="list-style-type: none"> • Restart the cycle.

Noises



Symptoms	Possible Cause & Solution
<p>Rattling and clanking noise</p>	<p>Foreign objects, such as keys, coins, or safety pins may be in the drum.</p> <ul style="list-style-type: none"> • Stop the appliance, check the drum for foreign objects. If the noise continues after the appliance is restarted, call for service.
<p>Thumping sound</p>	<p>Heavy wash loads may produce a thumping sound. This is usually normal.</p> <ul style="list-style-type: none"> • If the sound continues, the appliance is probably out of balance. Stop and redistribute the wash load. <p>Wash load may be out of balance.</p> <ul style="list-style-type: none"> • Pause the cycle and redistribute the load after the door unlocks.
<p>Vibrating noise</p>	<p>Package materials are not removed.</p> <ul style="list-style-type: none"> • Remove package materials. <p>Wash load may be unevenly distributed in the drum.</p> <ul style="list-style-type: none"> • Pause the cycle and redistribute the load after the door unlocks. <p>Not all leveling feet are resting firmly and evenly on the floor.</p> <ul style="list-style-type: none"> • Adjust the leveling of the appliance. Floor not rigid enough. • Check if the floor is solid and does not flex.

Operation

Symptoms	Possible Cause & Solution
<p>Water is leaking.</p>	<p>House drain pipes are clogged.</p> <ul style="list-style-type: none"> • Unclog waste pipes. Contact plumber if necessary. <p>Leakage is caused by improper installation of drain hose or clogged drain hose.</p> <ul style="list-style-type: none"> • Clean and straighten the drain hose. Check and clean the drain filter regularly. <p>Drain pump filter cap is not fitted correctly.</p> <ul style="list-style-type: none"> • Refit the drain pump filter.
<p>Appliance does not operate.</p>	<p>Control panel has powered off due to inactivity.</p> <ul style="list-style-type: none"> • This is normal. Press the Power button to turn the appliance on. <p>Appliance is unplugged.</p> <ul style="list-style-type: none"> • Make sure that the cord should be plugged securely into a working outlet. <p>Water supply is turned off.</p> <ul style="list-style-type: none"> • Turn the water supply tap completely. <p>Controls are not set properly.</p> <ul style="list-style-type: none"> • Make sure that the cycle should be correctly set. Close the door and press the Start/Pause button. <p>Door is open.</p> <ul style="list-style-type: none"> • Close the door and make sure that nothing should be caught under the door preventing it from closing completely. <p>Circuit breaker/fuse is tripped/blown.</p> <ul style="list-style-type: none"> • Check house circuit breakers/fuses. Replace fuses or reset breaker. The appliance should be on a dedicated branch circuit. The appliance will resume the cycle where it stopped once power is restored.
	<p>Control needs to be reset.</p> <ul style="list-style-type: none"> • Press the Power button, then reselect the desired programme and press the Start/Pause button.

	<p>Start/Pause was not pressed after a cycle was set.</p> <ul style="list-style-type: none"> • Press the Power button, then reselect the desired programme and press the Start/Pause button. The appliance is turned off if the Start/Pause button is not pressed within 15 minutes.
	<p>Extremely low water pressure.</p> <ul style="list-style-type: none"> • Check another tap in the house to make sure that household water pressure should be adequate.
	<p>Appliance is heating the water or making steam.</p> <ul style="list-style-type: none"> • The drum may stop operating temporarily during certain cycles, while water is safely heated to a set temperature.
Buttons may not function properly.	<p>The door cannot be opened for safety reasons once the appliance starts.</p> <ul style="list-style-type: none"> • Check if the CL is illuminated. You can safely open the door after the Door Lock icon turns off.
Door does not open.	<p>The door cannot be opened for safety reasons once the appliance starts.</p> <ul style="list-style-type: none"> • Check if the © icon is illuminated. You can safely open the door after the  icon turns off.
Appliance is not filling properly.	<p>Inlet Filter clogged.</p> <ul style="list-style-type: none"> • Make sure the inlet filters on the fill valves are not clogged.
	<p>Inlet hoses may be kinked.</p> <ul style="list-style-type: none"> • Check that inlet hoses are not kinked or clogged.
	<p>Insufficient water supply.</p> <ul style="list-style-type: none"> • Make sure that both hot and cold water taps are turned on all the way.

	<p>Hot and cold inlet hoses are reversed.</p> <ul style="list-style-type: none"> • Check inlet hose connections.
<p>Appliance does not drain water.</p>	<p>Kinked drain hose.</p> <ul style="list-style-type: none"> • Ensure that the drain hose is not kinked.
	<p>Drain located higher than 1.2 m above the floor.</p> <ul style="list-style-type: none"> • Make sure that the drain hose should not be higher than 1.2 m above the bottom of the appliance.
<p>Detergent is not dispensed completely or not dispensed at all.</p>	<p>Too much detergent is used.</p> <ul style="list-style-type: none"> • Follow the guidelines provided by the detergent manufacturer.
	<p>Drain Pump Filter may be blocked.</p> <ul style="list-style-type: none"> • Clean the Drain filter.
<p>Cycle time is longer than usual.</p>	<p>The load is too small.</p> <ul style="list-style-type: none"> • Add more items to allow the appliance to balance the loads. <p>Heavy articles are mixed with lighter items.</p> <ul style="list-style-type: none"> • Always try to wash articles with similar weight in order to allow the appliance to evenly distribute the weight of the load for spinning. <p>The load is out of balance.</p> <ul style="list-style-type: none"> • Manually redistribute the load if articles have become tangled.
<p>Cycle end is delayed</p>	<p>Unbalance is detected or suds removing programme is on.</p> <ul style="list-style-type: none"> • This is normal. The time remaining shown on the display is only an estimated duration. Actual time may vary.

Performance

Symptoms	Possible Cause & Solution
<p>Poor stain removal</p>	<p>Previously set stains.</p> <ul style="list-style-type: none"> Articles that have been previously washed may have stains which have been set. These stains may be difficult to remove and may require hand washing or pre-treating to aid in stain removal.
<p>Staining</p>	<p>Bleach or softener is dispensed too soon.</p> <ul style="list-style-type: none"> Dispenser compartment is overfilled. It makes bleach or softer dispensed rapidly. Always measure bleach or softener to prevent overfilling. Close the dispenser drawer slowly. <p>Bleach or softener was added directly to the wash load in the drum.</p> <ul style="list-style-type: none"> Always use the dispensers to ensure that laundry products are properly dispensed at the right time in the cycle. <p>Clothes were not properly sorted.</p> <ul style="list-style-type: none"> Always wash dark colours separately from light colours and whites to prevent discolouration. Never wash heavily soiled items with lightly soiled items.
<p>Wrinkling</p>	<p>Appliance is not unloaded promptly.</p> <ul style="list-style-type: none"> Always remove items from the appliance as soon as the cycle is complete. Appliance is overloaded. The appliance can be fully loaded, but the drum should not be tightly packed with items. The door of the appliance should be closed easily. <p>Hot and cold water inlet hoses are reversed.</p> <ul style="list-style-type: none"> Hot water rinse can set wrinkles in garments. Check the inlet hose connections. <p>Spin speed may be too high.</p> <ul style="list-style-type: none"> Set the spin speed to suit the garment type.

Odour



<p>Musty or mildewy odour in appliance</p>	<p>Inside of drum is not cleaned properly.</p> <ul style="list-style-type: none"> • Run the Tub Clean function regularly. <p>The drain hose is not properly installed, causing siphoning (water flowing back inside of the appliance).</p> <ul style="list-style-type: none"> • When installing the drain hose, make sure that it does not get kinked or blocked. <p>The detergent dispenser drawer is not cleaned regularly.</p> <ul style="list-style-type: none"> • Clean the detergent dispenser drawer, especially the top and the bottom of the drawer's opening. <p>Odours can occur if the drain hose is not properly installed, causing siphoning (water flowing back inside of the appliance).</p> <ul style="list-style-type: none"> • When installing the drain hose, make sure that it does not get kinked or blocked. <p>If the detergent dispenser drawer is not cleaned regularly, odours can occur from mold or foreign substances.</p> <ul style="list-style-type: none"> • Clean the detergent dispenser drawer, especially the top and bottom of the drawer's opening.
---	---

Wi-fi



Symptoms	Possible Cause & Solution
<p>Your home appliance and smart phone is not connected to the Wi-Fi network.</p>	<p>The password for the Wi-Fi that you are trying to connect to is incorrect.</p> <ul style="list-style-type: none"> • Find the Wi-Fi network connected to your smartphone and remove it, then register your appliance on LG SmartThinQ. <p>Mobile data for your smartphone is turned on.</p> <ul style="list-style-type: none"> • Turn off the Mobile data of your smartphone and register the appliance using the Wi-Fi network. <p>The wireless network name (SSID) is set incorrectly.</p> <ul style="list-style-type: none"> • The wireless network name (SSID) should be a combination of English letters and numbers. (Do not use special characters). <p>The router frequency is not 2.4 GHz.</p> <ul style="list-style-type: none"> • Only a 2.4 GHz router frequency is supported. Set the wireless router to 2.4 GHz and connect the appliance to the wireless router. To check the router frequency, check with your internet service provider or the router manufacturer. <p>The distance between the appliance and the router is too far.</p> <ul style="list-style-type: none"> • If the distance between the appliance and the router is too far, the signal may be weak and the connection may not be configured correctly. Move the location of the router so that it is closer to the appliance.

Warning

This content is compiled from multiple sources and is provided for reference purposes only. It may not be complete or fully applicable to all situations. If you are unable to resolve your issue, please contact the product manufacturer or an authorized service provider for official support.

