

IMPORTANT SAFETY INSTRUCTIONS

These warnings are provided in the interests of your safety. Ensure that you understand Them all before installing or using this appliance. Your safety is of paramount importance. If you are unsure about any of the meanings or these warnings contact the Customer Care Department.

Installation

- This appliance is heavy. Care should be taken when moving it.
- It is dangerous to alter the specifications or attempt to modify this product in any way.
- Ensure that the appliance does not stand on the electrical supply cable. If the supply cord is damaged, it must be replaced by a special cord available from your Local Service Centre.
- Any electrical work required to install this appliance should be carried out by a qualified electrician or competent person.
- Whenever possible, the back of the appliance should be close to a wall but leaving the required distance for ventilation as stated in the installation instructions.
- The appliance should be left for 2 hours after installation before it is turned on, in order to allow the refrigerant to settle.

Child Safety

- This appliance is not intended for use by young children or infirm persons unless they have been adequately supervised by a responsible person to ensure that they can use the appliance safely.
- Yong children should be supervised to ensure that they do not play with the appliance.

During Use

- This appliance is designed for domestic use only, specifically for the storage of edible foodstuffs only.
- Frozen food should not be refrozen once it has thawed out.
- Do not place carbonated or fizzy drinks in the freezer.
- Ice lollies can cause frost/freezer bums' if consumed straight from the freezer.
- Do not remove items from the freezer if your hands are damp/wet, as this could cause skin abrasions or frost/freezer bums.

Maintenance and Cleaning

- Switch off, and unplug the appliance before carrying out any cleaning or maintenance work.
- Do not use sharp instruments to scrape off frost or ice. (See defrosting instructions).

CAUTION:

- You must not use any mechanical device to speed up the defrosting process.
- Do not damage the refrigerant circuit.
- You must not use any electric appliance inside the appliance except those that are recommended by the manufacturer.

Servicing

This product should be serviced by an authorized service agent, and only genuine spare parts should be used.

- Under no circumstances should you attempt to repair the machine yourself. Repairs carried out by inexperienced persons may cause injury or serious malfunctioning. Contact your local Service Centre.

Warnings

- This appliance is not intended for use by persons (including children) with reduced physical, sensory or mental capabilities, or lack of experience and knowledge, unless they have been given supervision or instruction concerning use of the appliance by a person responsible for their safety.
- It is hazardous for anyone other than an Authorised Service Person to service this appliance. In Queensland - the authorized Service Person MUST hold a Gas Work Authorisation for hydrocarbon refrigerants, to carry out servicing or repairs which involve the removal of covers.
- Children should be supervised to ensure that they do not play with the appliance. If the supply cord is damaged, it must be replaced by the manufacturer, its service agent or similarly qualified persons in order to avoid a hazard.
- Keep ventilation openings, in the appliance enclosure or in the built-in structure, clear of obstruction.
- Do not use mechanical devices or other means to accelerate the defrosting process, other than those recommended by the manufacturer.
- Do not damage the refrigerant circuit.
- Do not use electrical appliances inside the food storage compartments of the appliance, unless they are of the type recommended by the manufacturer.

- Please abandon the refrigerator according to local regulators for it use flammable blowing gas and refrigerant

Do not store explosive substances such as aerosol cans with a flammable propellant in this appliance.

This appliance is intended to be used in household and similar applications such as

- staff kitchen areas in shops, offices and other working environments;
- farm houses and by clients in hotels, motels and other residential type environments;
- bed and breakfast type environments;
- catering and similar non-retail applications.

Description of the Appliance

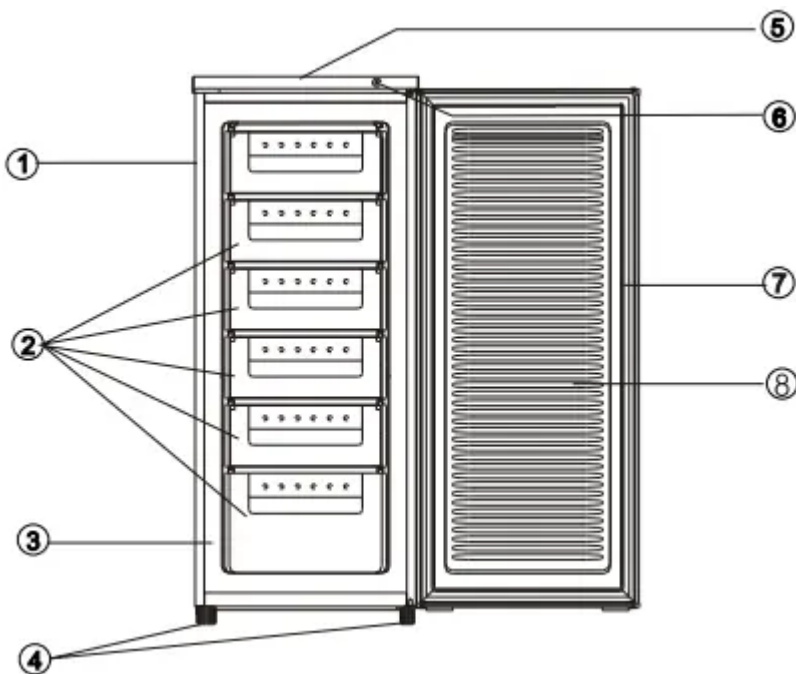

1. Cabinet
2. Plastic drawer with plastic cover
3. Compressor(at the rear of cabinet)
4. Adjustable Feet
5. Worktop
6. Thermostat Knob
7. Door Gasket
8. Door Assembly

USING THE APPLIANCE

 This appliance is designed for domestic use only, specifically for the storage of edible foodstuffs.

This appliance is designed to operate in ambient temperatures (surrounding air temperature) between 16°C(50 F) and 32°C

If these temperatures are exceeded i.e., colder or warmer, the appliance will not operate correctly. Should the ambient temperatures be exceeded for long periods, the temperature in the freezer section will rise above -18 C and food spoilage may occur.

Before Use

Remove all securing tapes and foam under the condenser at the back of the cabinet. Wash the inside of the appliance with lukewarm water with a little bicarbonate of soda added (5ml to 0.5 litre of water). Do not use soap or detergent as the smell may linger. Dry the appliance thoroughly.

Thermostat Control

The thermostat control situated in the control panel regulates the temperature of the freezer compartment.

Position MIN - Cold

Position NORMAL- Colder. Normally set at this position.

Position MAX - Coldest, the compressor works continuously in this mode.

The temperature will be affected by:

- Room temperature
- How often the door is opened
- How much food is stored
- Position of the appliance

In determining the correct temperature control setting, all these factors have to be considered and some experimentation may be necessary

 Do not allow children to tamper with the controls or play with the product.

 Do not use detergents, abrasive powders, highly perfumed cleaning products, wax polishes or products containing alcohol.

To Start the Appliance

1. Allow the appliance to stand for 2 hours after installation.

2. Plug in the appliance and switch on at the mains supply.
3. Turn the thermostat control to the required setting. A midway setting is usually suitable for normal operation (see thermostat control).
4. Leave the appliance for approximately 4 hours for the correct temperature to be reached before placing food inside.

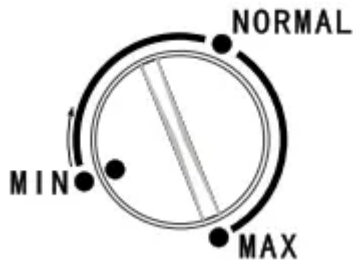

The Freezer Compartment

The freezer temperature is controlled automatically by the thermostat situated in the control panel.

Due to the different installations, methods of usage and weather conditions, adjustments to the temperature settings may be required.

i These are best assessed against a temperature reading on a thermometer buried in the frozen food. The reading must be taken quickly as the thermometer temperature will rise rapidly after removal.

Freezing Fresh Food

The maximum quantity of food you can freeze in 24 hours is 6.5kg. Place the fresh food on the freezer compartment. Food may need rearranging to achieve this.

During the freezing process the temperature of fresh food should be reduced quickly so that ice crystals are kept as small as possible to prevent damaging the structure of food. If freezing takes place slowly large ice crystals form and these will affect the quality of food once it has defrosted.

Packets to be frozen should be placed in the basket in contact with the baskets surface as far as possible and spaced apart to allow cold air to circulate between them. They should not touch existing packets.

! Frozen food should not be refrozen once it has thawed out.

Do not remove items from the freezer if your hands are damp/wet, as this could cause skin abrasions or frost/freezer bums'.

Frozen Food Storage

Pre-packed commercially frozen food should be stored in accordance with the manufacturer's instructions and should be put in the freezer as soon as possible after purchase. Your freezer provides for long term storage which generally means up to 3 months but the length of the time can vary and it is important to follow the recommended times shown on packets of commercially frozen food.

 *Do not place sealed containers or carbonated liquids such as fizzy drinks into the freezer as it creates pressure on the container which may cause it to explode resulting to damage to the freezer.*

Ice cubes and ice lollies should not be consumed immediately after removal from the freezer as it may result in low temperature skin abrasions. Manufacturers storage times should be adhered to.

Hints and Tips

- Any opened packets of frozen food, should be rewrapped in airtight materials to prevent surface evaporation which causes drying or 'freezer burn'.
- Frozen food which is allowed to thaw accidentally should either be used immediately or thrown away. Alternatively if the food is uncooked and has not been completely defrosted it can be cooked and then refrozen.
- Aim to check dates on packets and rotate food regularly. Although storage longer than recommended is not harmful, flavours and textures begin to change.

HINTS AND TIPS

Normal Operating Sounds

- You may hear faint gurgling or bubbling sounds when the refrigerant is pumped through the coils or tubing at the rear, to the cooling plate/evaporator.
- When the compressor is on, the refrigerant is being pumped round, and you will hear a whirring sound or pulsating noise from the compressor.
- A thermostat controls the compressor, and you will hear a faint 'click' when the thermostat cuts in and out.

Food Storage

- To obtain the best results from your appliance, neither hot foods nor liquids which may evaporate, should be placed in the compartment.
- Avoid buying frozen food if you cannot store it straight away. The use of an insulated container is advisable. When you arrive home place the frozen food in the freezer immediately.

- Keep the time between buying chilled food and placing it in your freezer as short as possible.
- Do not push food together too much, try to allow air to circulate around each item.
- Do not store food uncovered.
- Ensure that food placed in the freezer is dated and labeled and used in date order to ensure that food is consumed at its best.
- Remove suspect food from your freezer and clean, refer to cleaning and maintenance.

Energy Saving Advice

- Do not install the appliance close to sources of heat, such as a cooker, dishwasher or radiator.
- Locate the appliance in a cool well ventilated room and make sure that the air openings of the cabinet are not obstructed.
- Avoid unnecessary frosting in the cabinet by packing all foodstuffs into airtight packages before placing them in the freezer.
- Always leave warm food to cool down to room temperature before placing in the freezer.
- Food which is to be frozen (when cool) should be placed in the fridge before being transferred to the freezer.
- Thaw frozen food in the fridge. This will ensure safer defrosting of foods.
- Try to avoid keeping the door open for long periods, or opening the door too frequently as warm air will enter the cabinet, and cause the compressor to switch on unnecessarily.
- Ensure there are no obstructions preventing the door from closing properly.

In the Event of a Power Failure

If there is a power failure during the storage of frozen foods, keep the door closed. If the temperature within your freezer should rise do not refreeze the food without checking it's condition.

The following guidelines should assist you:

Ice Cream: Once thawed should be discarded.

Fruit and Vegetables: If soft should be cooked and used up.

Bread and Cakes: Can be refrozen without danger.

Shellfish: Should be refrigerated and used up quickly.

Cooked Dishes: i.e. casseroles, should be refrigerated and used up.

Large Pieces of Meat: Can be re-frozen providing there are ice crystals remaining within them.

Small Joints: Should be cooked and then re-frozen as cooked dishes.

Chicken: Should be cooked and re-frozen as a fresh dish

MAINTENANCE AND CLEANING

 Before any maintenance or cleaning work is carried out DISCONNECT the appliance from the ELECTRICITY supply

Internal Cleaning

Clean the inside and accessories with warm water and bicarbonate of soda (5ml to 0.5 litre of water). Rinse and dry thoroughly.

 Do not use detergents, abrasive powders, highly perfumed cleaning products, wax polishes or cleaning products containing bleach or alcohol.

External Cleaning

Wash the outer cabinet with warm soapy water.

 Do NOT use abrasive products.

There are sharp edges on the underside of the product so care should be taken when cleaning.

To Defrost the Freezer

1. Wrap any food in layers of newspaper or blankets.
2. Switch the appliance off at the wall socket and remove the plug.
3. Open the freezer door.
4. Place a suitable container to collect the defrost water.
5. After defrosting, clean and dry the interior.
6. Switch the appliance on and replace any frozen food.



- Defrosting can be speeded up by putting bowls of hot (not boiling) water in the freezer and loosening the frost with a suitable plastic scraper.
- If the temperature of frozen food is allowed to rise during defrosting, its storage life may be shortened.

When the Appliance is Not in Use

When the appliance is not in use for long periods, disconnect from the electricity supply, empty all of the food and clean the appliance, leaving the door ajar to prevent unpleasant smells.

WHAT HAPPENS IF SOMETHING GOES WRONG

BEFORE contacting your local service centre, check the following points:

Symptom	Solution
No power to the appliance	Check there is power at the socket.
	Check there is not a power cut by checking the household lights.
	Check the fuse has not blown.
The temperature in the freezer section is too high	Check the ambient temperature is within appliances operating limits of 10°C to 43°C. Relocate the appliance if necessary.
	Check the thermostat is turned to the correct Setting relative to ambient conditions.
The freezer door will not open	- Has door just been opened? If so leave for a few minutes to allow the air pressure to equalise.
The compressor runs continuously	Make sure that the thermostat is not set to Max . See Thermostat Control on page 5 for details.
	Check that the door is closed.
	Large quantities of food have recently been placed in the cabinet / and or door is frequently opened.
	Check that air ventilation is not obstructed.
Excessive frost and ice has built up	Ensure the door is not left open.
	Check that nothing is preventing the door from closing.
	Is the door gasket intact and clean.
	Has advised periodic defrosting been carried out.
Noise	Refer to normal operating sounds.

If after the above checks there is still a fault call your local Service Centre.

In-guarantee customers should ensure that the above checks have been made as charges will apply if the fault is not a mechanical or electrical breakdown.

Please note that proof of purchase is required for in-guarantee service calls.

Door Reversal

The side at which the door opens can be changed from the right side (as supplied) to the left side, if the installation site requires.

 **Warning!** When changing the side at which the door opens, the appliance must not be connected to the mains. Remove plug from the mains beforehand.

Tilt the appliance slightly towards the rear and prop it securely.

Unscrew the door hinge screws and remove the hinge pin bracket. Open the door a little way and take it out downwards.

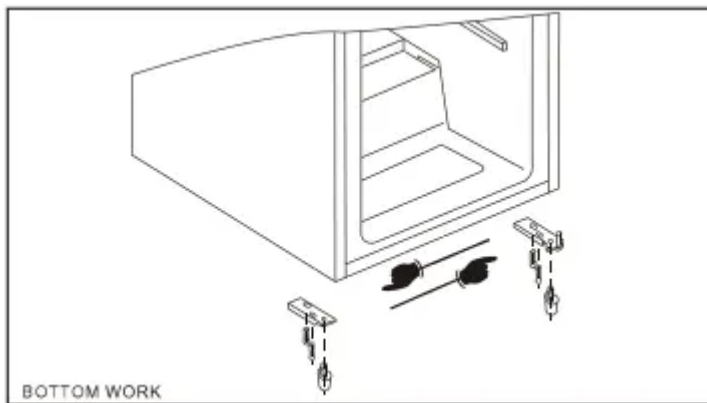

Unscrew the upper pin and screw it into place on the opposite side. Fit the door into the upper pin and close it.

Screw the hinge pin bracket securely into place on the opposite side using the screws.

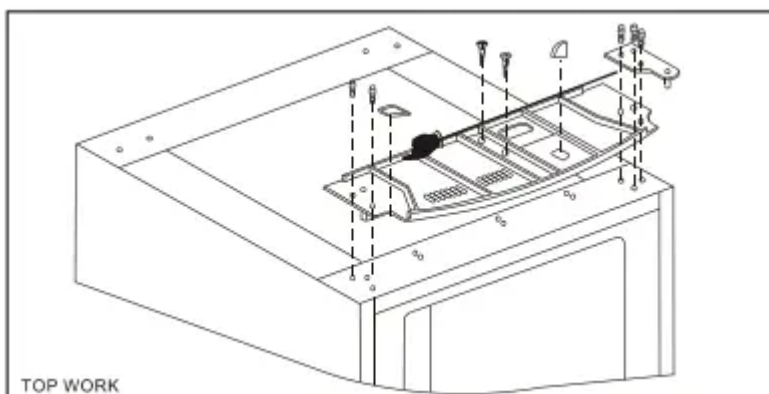

Installation Requirements

To ensure correct operation this appliance must not be located where the temperatures will fall below 10°C or rise above 43°C

Avoid the following locations: unventilated kitchen, outhouse, conservatory, garage.

For correct operation this appliance must be installed:

In a dry atmosphere.

Out of direct sunlight.

Away from extreme temperature (not next to a cooker or other sources of heat).

Your appliance will be heavy when loaded with food and must therefore be stood on a strong firm floor.

Ventilation Requirements

Gently push into place until the back of the freezer keeps a required distance from wall.

When in position a 50 mm (2") clear space above the appliance should be maintained.

If space above the appliance is not available, clearance of 25mm (1") should be maintained on both sides.

 Ensure that the appliance does not stand on the electrical supply cable.

Parts which heat up should not be exposed. Whenever possible, the back of the appliance should be close to a wall but leaving the required distance for ventilation.

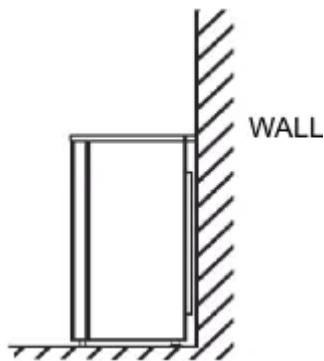

Levelling

The appliance should be level, to eliminate rocking:

Ensure the appliance is upright and both adjusters are in firm contact with the floor so that the cabinet is level.

Adjust the level by screwing out the appropriate level adjuster at the front, (use your fingers or a suitable spanner).

 This appliance is heavy. Care should be taken when moving it.

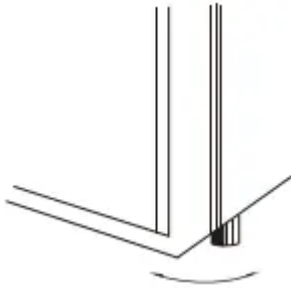

** For the detailed specifications, please refer to the nameplate at the back of the freezer. The specifications are subject to change without prior notice.*

Warning

This content is compiled from multiple sources and is provided for reference purposes only. It may not be complete or fully applicable to all situations. If you are unable to resolve your issue, please contact the product manufacturer or an authorized service provider for official support.

Document generated by [ManualsFile](#)

