

SET UP & USE

PARTS & FEATURES

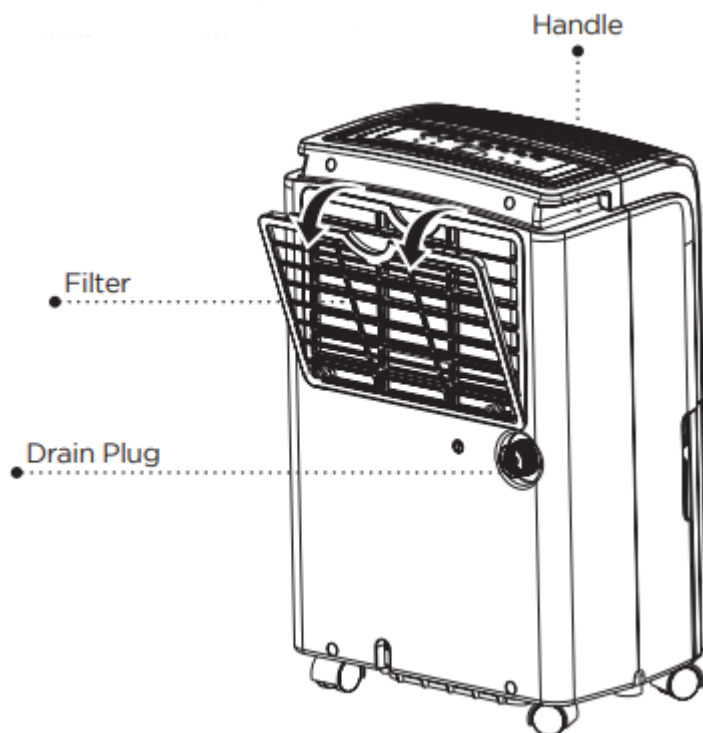

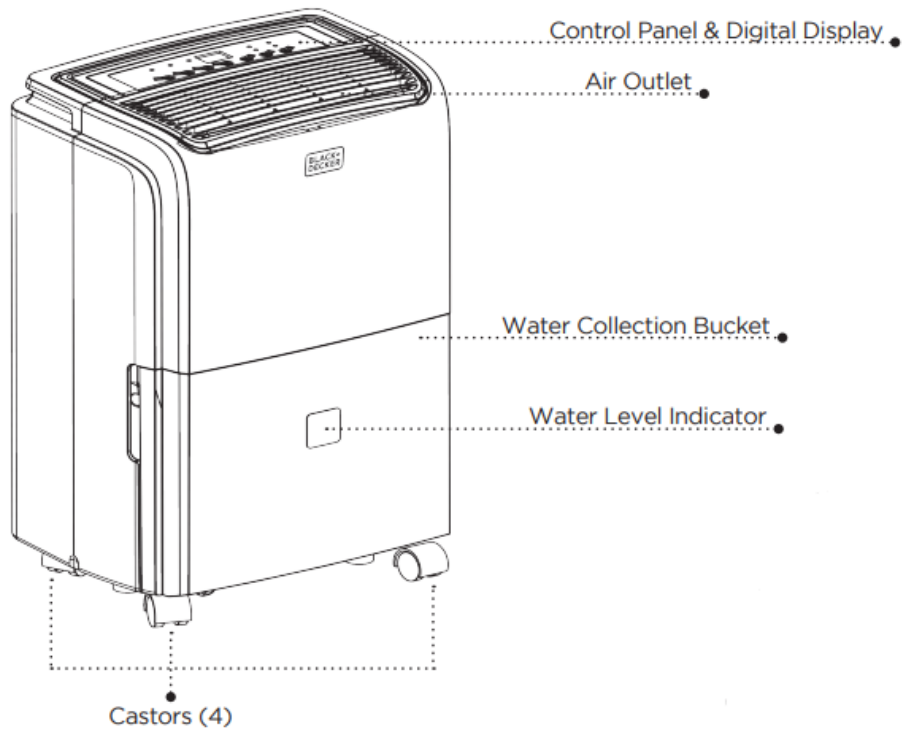
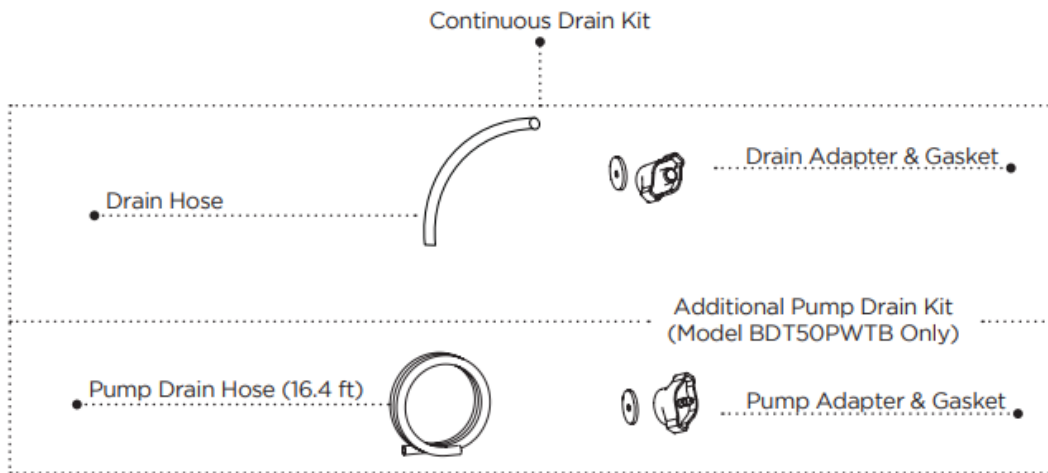

CONTROL PANEL

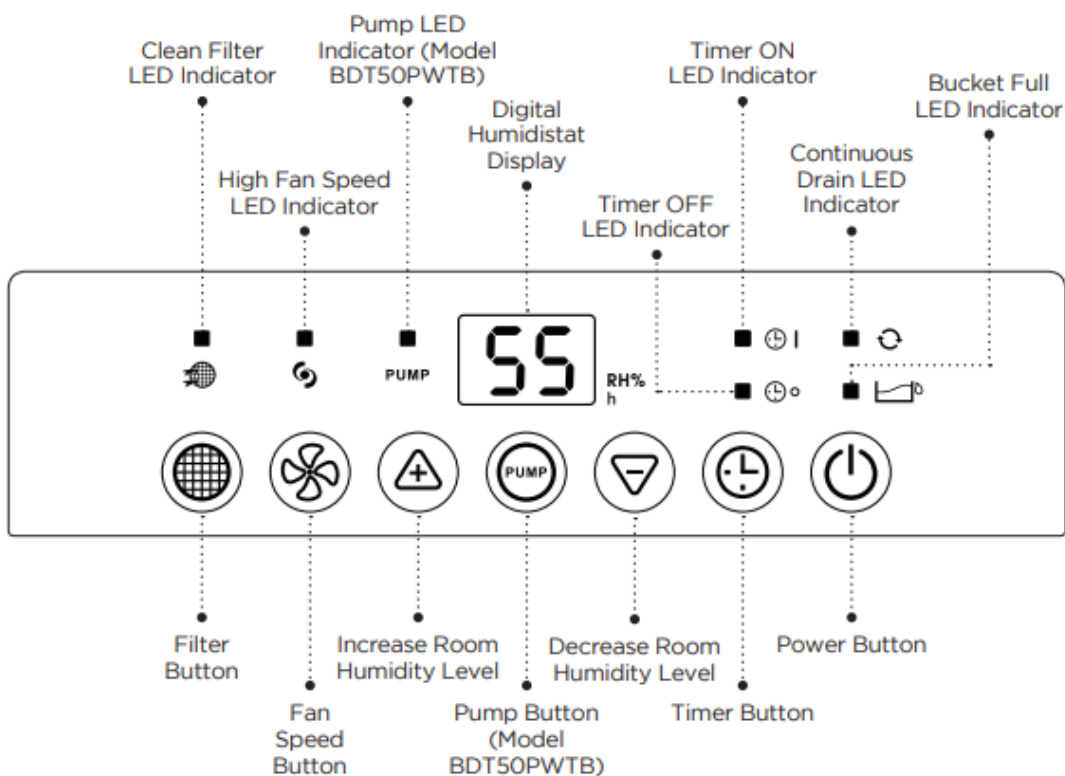

ERROR CODES: (Will appear in the digital humidistat display)

E1: The temperature sensor on the discharge pipe may be faulty and may need to be changed.

E2: The temperature sensor on the heat exchanger may be faulty and may need to be changed.

E3: If the E3 error code is shown on the digital display, check to make sure the room temperature is below 90°F. If the room temperature is too high, place the dehumidifier in a location where the

room temperature is below 90°F for at least 2 hours before operating again. If the E3 code appears again, contact the customer service department.

EH: The humidity sensor may be faulty and may need to be changed.

P1 (Model BDT50PWTB): Bucket is not in the proper position. Make sure the bucket is in place and securely seated for the dehumidifier to operate. If error code reappears after adjusting the bucket, please contact the customer service department.

If any of these error codes appear and remain in the display, please contact the customer service department as listed on page 18 of the user manual.

INSTALLATION GUIDE

When you open the box, you should have received:

Portable dehumidifier

User Guide

Castors (4)

Continuous Drain Kit

If you purchased a model with a pump (BDT50PWTB) there will be an additional pump drain kit

To Install Castors:

1. For the 20 pint model (BDT20WTB) and the 30 pint model (BDT30WTB) gently lift the lid of the bucket (see fig 1).

For the 40 pint model (BDT40WTB) and the 50 pint models (BDT50WTB, BDT50PWTB) gently lift off the lid of the bucket (see fig 2). Do not pull on handle.

2. Tilt the dehumidifier no more than 45 degrees and push to insert the castors into the base of the unit. Make sure the ring around the castor is flush against the bottom of the dehumidifier. (see fig. 3).

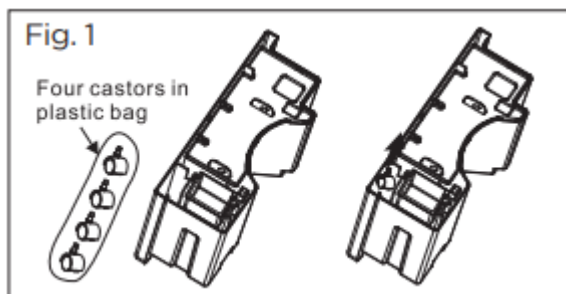

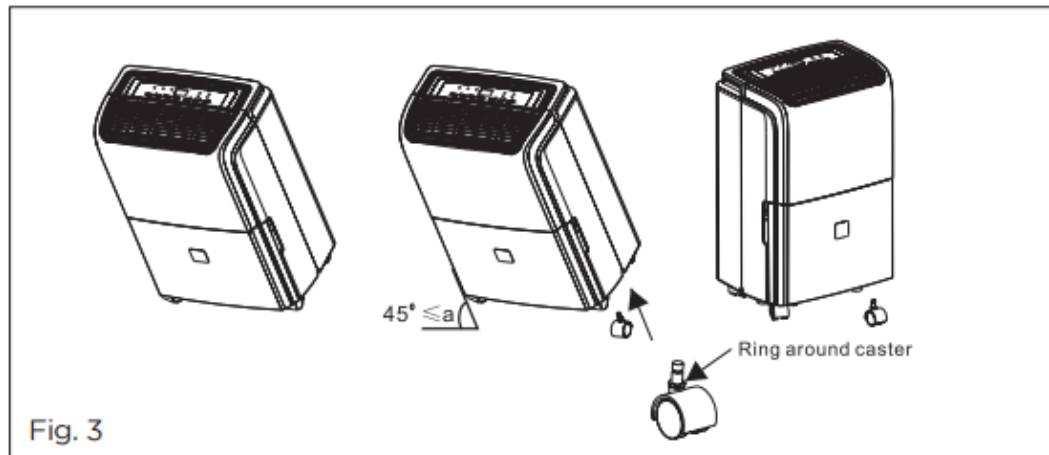
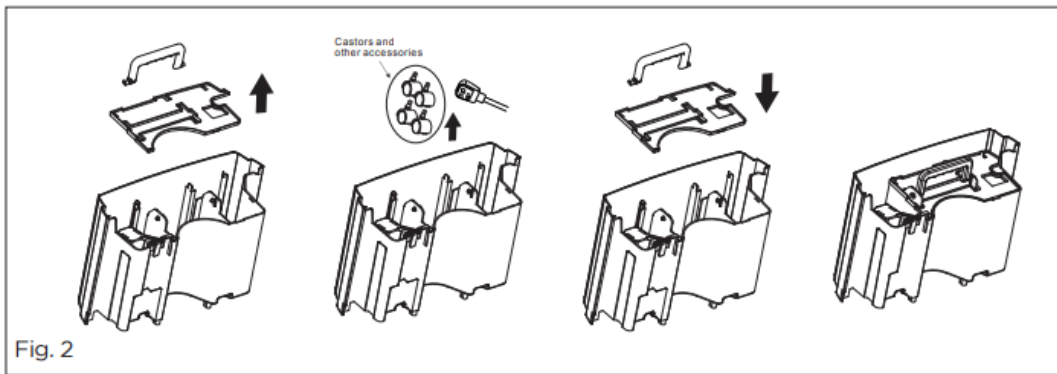

BEFORE FIRST OPERATION

1. Grip each side of the bucket and pull to remove the bucket from the dehumidifier (Fig. 4).

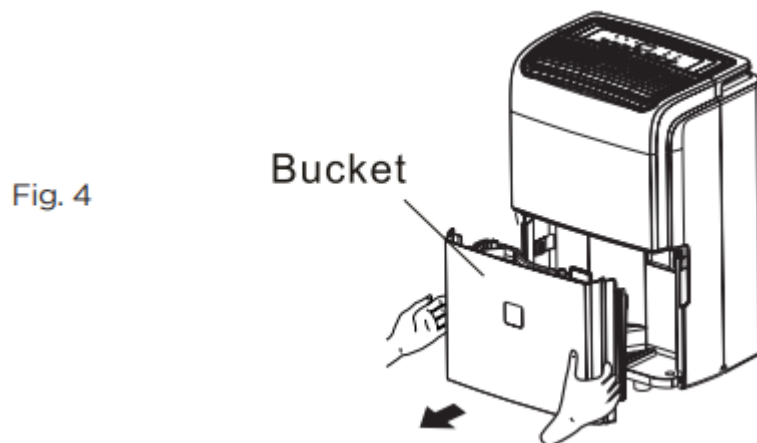

2. Check inside the bucket to make sure the float system is in the correct position. If not, place the float in the correct position (Fig. 5).

Fig. 5

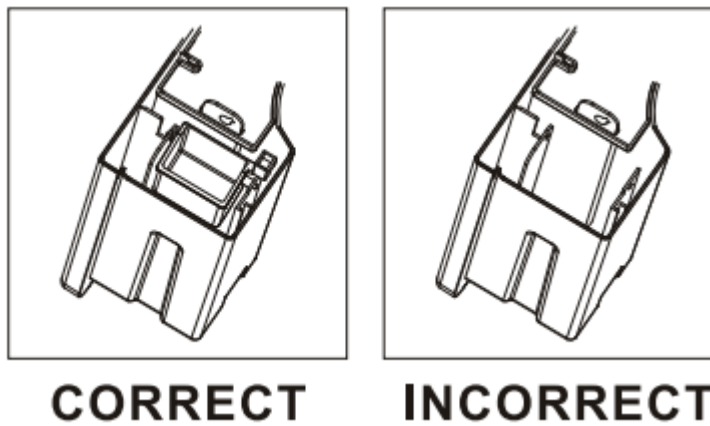

3. Re-insert the bucket once you have determined the float system is in the correct position (Fig. 6)

Fig. 6

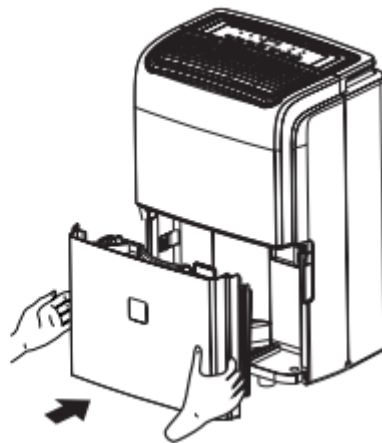





The float in the bucket is essential to the “bucket full” system working properly. Do not remove the float and make sure the float can rotate freely.

OPERATION INSTRUCTIONS

NOTE: Unit may shut off automatically during 24 hour period if collection bucket is full (see below). If continuous drainage mode is utilized, and drain hose is connected, the unit will operate continuously (see page 12).



1. Press the POWER button once to turn the unit on. Press POWER button again when you're ready to turn it off.





2. Press the  or  buttons under the display to select the desired relative humidity in the room. Each press will change the room humidity by 5%. The room humidity is selectable from 35-80% or continuous. The unit will cycle on and off to maintain the humidity level chosen on the digital display. After few seconds, it will display the ambient humidity. When the ambient humidity is lower than the set humidity, the compressor will stop running, and after few minutes the fan will stop running.

3. If you want the dehumidifier to operate continuously regardless of the room humidity, press  button until you see “CO” on the display. This will enable continuous operation and the  indicator will light up on the control panel.

4. Press the FAN SPEED button to select between High and Low Speeds. If HIGH speed is selected the  indicator will light up.

TIMER FUNCTION

To program the unit to automatically turn ON, press the TIMER button when the unit is OFF. Press the  or  to increase the timer in 30 minute increments up to 10 hours. After 10 hours, each press of the  will increase the timer in 1 hour increments up to 24 hours. Once the desired time is reached, the unit will automatically turn ON.

To program the unit to automatically turn OFF, press the TIMER button when the unit is ON. Each press of the  or  buttons will change the timer setting in 30 minute increments up to 10 hours. After 10 hours, each press of the  or  buttons will increase or decrease the timer in 1 hour increments up to 24 hours. Once the desired time is over, the unit will automatically power OFF.

FULL WATER COLLECTION BUCKET

When the water collection bucket is full, the unit will shut off automatically, make a beeping noise and the BUCKET FULL indicator will light. The dehumidifier will not run again until the bucket is emptied and properly placed back inside the unit.

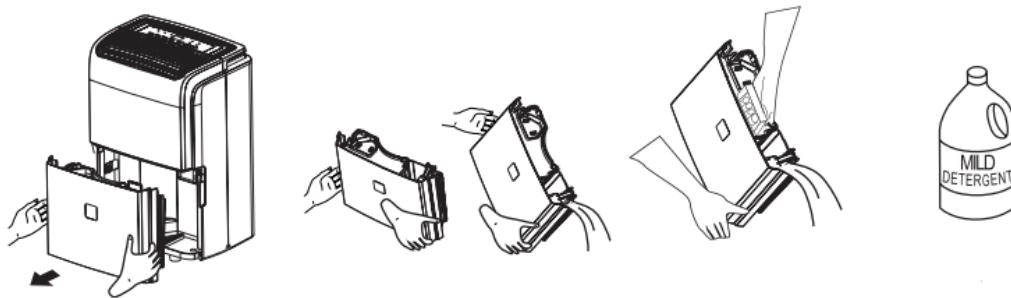

NOTE: When the bucket is full or removed from the unit, the compressor will turn off but the fan will continue to run for a few minutes. This is completely normal. The dehumidifier will not be removing moisture from the air at this time.

Over time, the dehumidifier will create a more stable humidity in the area it is located.

The more moisture the dehumidifier removes from the air, the more often you may have to empty the bucket unless you choose to use the continuous drain option. The number of times the bucket will need to be emptied daily will depend on the dehumidifier model.

BDT20WTB	20 pints of moisture removed every 24 hours	empty maximum of 3 times per day
BDT30WTB	30 pints of moisture removed every 24 hours	empty maximum of 4 times per day
BDT40WTB	40 pints of moisture removed every 24 hours	empty maximum of 3 times per day
BDT50PWTB/ BDT50WTB	50 pints of moisture removed every 24 hours	empty maximum of 4 times per day

CAUTION: Do not place the water collection bucket on the floor when it is full as it is uneven on the bottom and may spill.

FILTER CLEANING

When the filter needs to be cleaned, the filter indicator light will come on (after approximately 250 hours of use). Remove the filter from the back of the unit by using your thumbs to press down on the filter tabs directly above the filter.



Clean the filter with warm, soapy water and dry thoroughly before putting back in place. Once filter is back in the unit, press the FILTER button to reset the filter indicator.

CAUTION: Do not clean the filter in a dishwasher. Do not operate the dehumidifier without the included filter in place.

AUTOMATIC DEFROST

When frost builds up on the evaporator coils, the compressor will cycle off and the fan will continue to run until the frost disappears. When the coils are completely defrosted, the compressor or fan (depending on model) will automatically restart and dehumidification will resume.

AUTOMATIC RESTART

In the event of a power interruption such as a power outage or the plug being disconnected from the outlet, your dehumidifier will automatically restart in the same setting once power has been restored to the unit. The only functions/ features that will have to be restored manually upon resumption of power are the timer function and the child lock mode.

CONTINUOUS DRAINAGE

Water can be automatically emptied by attaching the clear hose (included) or a standard garden hose (not included) to the drain port on the back of the dehumidifier. This will allow the unit to run continuously (depending on the selected humidity level) without having to empty the unit's water collection bucket.

To use with clear hose (included)

1. Place dehumidifier on a perfectly level surface.
2. Unscrew and remove drain cap to access the garden hose nozzle threads. (See fig. 7)
3. Insert the included gasket into the front of the included drain adaptor (see fig. 8).
4. Force the included clear hose on to the drain adaptor (see fig. 9).
5. Turn drain adaptor clockwise on to the nozzle thread on the back of the unit (see fig. 9).
6. Once securely installed, lead the drain hose to a nearby drain lower than the height of the drain plug. (Make sure there are no kinks or knots in the hose)
7. Turn on the unit and select desired relative humidity level.

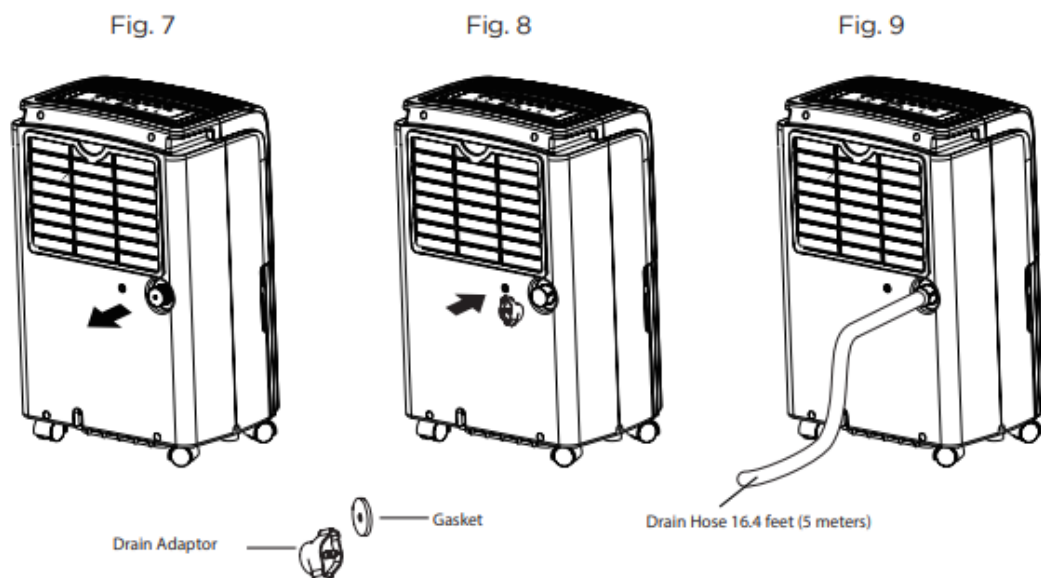

To use with standard garden hose (not included)

1. Place dehumidifier on a level surface.
2. Unscrew and remove drain cap to access the garden hose nozzle threads.

3. Screw on garden hose to the now accessible nozzle threads.
4. Once securely installed, lead the drain hose to a nearby drain lower than the height of the drain plug. (Make sure there are no kinks or knots in the hose)
5. Turn on the unit and select desired relative humidity level.

NOTE: The thread standard for garden hoses in the U.S. is known as GHT with an outer diameter of 11/16 inches and a pitch of 11.5 TPI.

CAUTION: Placing the dehumidifier on an uneven surface or improper hose installation may result in water filling up the bucket and causing the unit to shut off. Empty the bucket if the auto shutoff occurs, check dehumidifier location for stability and check hose for proper installation. The collection bucket must be properly placed in the dehumidifier for it to operate.

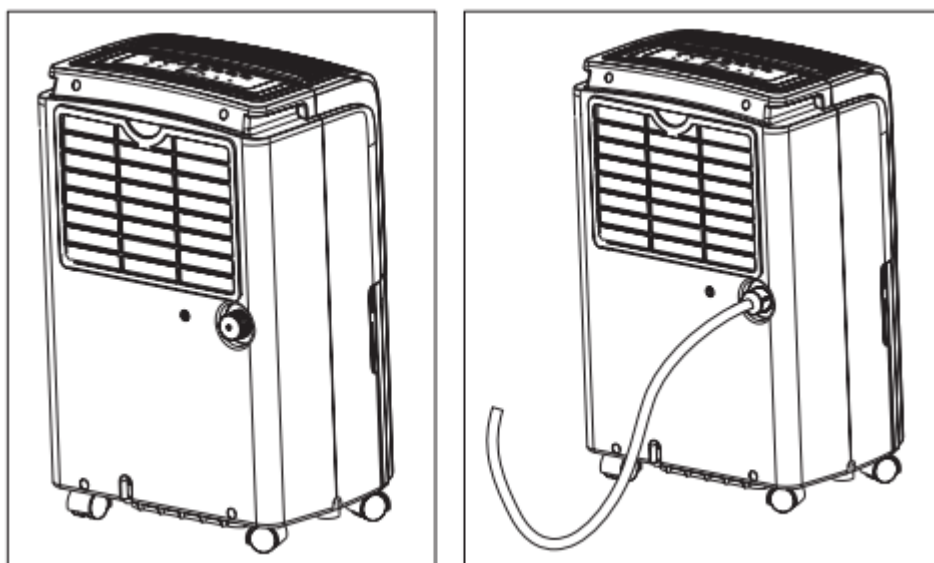

INTERNAL PUMP MODE

The internal pump allows the unit to operate without having to empty the bucket and requires the installation of the included pump drain hose kit. To install the kit, remove the drain cap on the back of the unit (see Fig. 6 on page 12). Insert the included gasket into the front of the included pump adapter (see Fig. 7 on page 12). Force the included CLEAR drain hose on to the pump adapter and turn adapter clockwise on to the garden hose type nozzle on the back of the unit (see Fig. 8 on page 12). Once securely installed, lead the drain hose to a nearby drain, sink or out a window. Turn on the dehumidifier and press the PUMP button to activate the internal pump. The “PUMP” LED indicator should illuminate.

NOTE: Be aware that a small internal tank must fill before the pump will function and operation may be intermittent depending on the amount of humidity in the air at the time. Water can be pumped up to 16' in height from base of unit. Make sure there are no kinks or knots in the hose.

NOTE: Even once you activate the internal pump, you may not get water running out of the drain hose right away as there is a small, internal tank which must fill first. Also, the water will not run out

of the drain hose on a continuous basis unless the dehumidifier has been placed in a very high humidity area. Otherwise, it will power on and off as needed based on the home comfort mode set by the user and the ambient humidity level in the area.

Water can be pumped up to 16' in height from base of drain plug. Make sure there are no kinks or knots in the hose. ONLY use included clear drain hose when utilizing the internal pump.

GENERAL INFORMATION

Recommended humidity levels: 30%-50% (Too dry, less than 15%, too humid, greater than 50%)

During operation, it is normal for the exhaust coming from the side of the dehumidifier to be warm.

Caused by preliminary factory testing, there may also be a small amount of water present in the bucket before using the dehumidifier for the first time, which is normal.

Operating temperature: 41°F-90°F (5°C-32°C)

Operating humidity: 30% RH-90% RH

SPECIFICATIONS

BDT20WTB

Dehumidifying capacity: 20 pints per day

Bucket capacity: 8 pints

Air flow volume (high/low): 182/155 CFM

Power: 115v, 60 Hz, 3.5A

Power consumption: 260 watts

BDT30WTB

Dehumidifying capacity: 30 pints per day

Bucket capacity: 8 pints

Air flow volume (high/low): 182/155 CFM

Power: 115v, 60 Hz, 4.2A

Power consumption: 330 watts

BDT40WTB

Dehumidifying capacity: 40 pints per day

Bucket capacity: 14.3 pints

Air flow volume (high/low): 182/155 CFM

Power: 115v, 60 Hz, 5.0A

Power consumption: 395 watts

BDT50WTB

Dehumidifying capacity: 50 pints per day

Bucket capacity: 14.3 pints

Air flow volume (high/low): 182/155 CFM

Power: 115v, 60 Hz, 7.0A

Power consumption: 540 watts

BDT50PWTB

Dehumidifying capacity: 50 pints per day

Bucket capacity: 14.3 pints

Air flow volume (high/low): 182/155 CFM

Power: 115v, 60 Hz, 7.0A

Power consumption: 540 watts

CLEANING & CARE

CARE AND CLEANING GUIDE

NOTE: Make sure power is off and power cord is not plugged into electrical outlet prior to performing and cleaning to the unit

The water collection bucket should be cleaned every few weeks to prevent the growth of mold, mildew and bacteria. Use a mild detergent to clean the bucket. Once clean, completely dry the bucket and place it back inside the humidifier.

To keep the unit housing clean, keep the unit from being exposed directly to the sun or to prevent color fading. Clean the surface with a damp cloth and dry with a soft towel.

STORING FOR EXTENDED PERIOD OR TRANSPORTING THE UNIT

1. Unplug the unit.
2. Clean or replace filter.
3. Empty any excess water from water collection bucket.
4. Store in dry place.

TROUBLE SHOOTING

Troubleshoot your problem by using the chart below. If the dehumidifier still does not work properly, contact W Appliance Co. customer service center or the nearest authorized service center.

Customers must never troubleshoot internal components.

TROUBLE	POSSIBLE CAUSE	POSSIBLE REMEDY
Dehumidifier does not start	The dehumidifier is unplugged	Make sure the dehumidifier's plug is pushed completely into the outlet
	The fuse is blown/circuit breaker is tripped	Check the house fuse/circuit breaker box and replace fuse or reset breaker
	Dehumidifier has reached its present level or the bucket is full	The dehumidifier automatically turns off when either condition occurs. Change to a lower setting or empty the water bucket and replace properly
	Bucket is not in the proper position	The bucket must be in place and securely seated for the dehumidifier to operate
	Power failure	There is a protective time delay (up to 3 min.) to prevent tripping of the compressor overload. For this reason, the unit may not start normal dehumidification for 3 minutes after it is powered back on
Dehumidifier does not dry the air as it should	Not enough time allowed for unit to remove moisture	When first installed, allow at least 24 hours to maintain the desired dryness
	Airflow is restricted	Make sure there are no curtains, blinds, or furniture blocking the front or back of the dehumidifier.
	Dirty filter	See the FILTER CLEANING section on page 10
	The humidity control may not be set low enough	For drier air, press the  button to lower the percent humidity desired in the room or set the dehumidifier to CO for maximum dehumidification
	Doors and windows may not be closed tightly	Check that all doors, windows and other openings are securely closed
	Clothes dryer may be blowing moist air into the room	Install the dehumidifier away from the dryer. The dryer should be vented outside.
	Room temperature is too low	Moisture removal is best at higher room temperatures. Lower room temperatures will

TROUBLE	POSSIBLE CAUSE	POSSIBLE REMEDY
		reduce the moisture removal rate. This model is designed to operate at temperatures above 41°F
Dehumidifier runs too much	The area is too large for the capability of the dehumidifier	The capacity of your dehumidifier may not be adequate for the room size
	Doors and windows are open	Close all doors and windows to the outside
Frost appears on the coils	The dehumidifier has recently been turned on or the room temperature is below 41°F	This is normal. Frost will usually disappear within 60 minutes. For details, see "AUTO DEFROST" section on page 11
Controls cannot be set	The compressor will turn off and the fan will automatically continue to run for approximately 3 minutes at a fixed setting	This is normal. Wait approximately 3 minutes and set the fan speed at the desired level
Fan noise	Air is moving through the unit	This is normal
Water on the floor	Hose connection may be loose	Check the hose connection. See the CONTINUOUS DRAINAGE SECTION on page 12
	Hose is attached but not draining into a drain	Disconnect the hose if using the bucket or place the hose near a drain

Troubleshoot your problem by using the chart below. If the dehumidifier still does not work properly, contact W Appliance Co. customer service center or the nearest authorized service center. Customers must never troubleshoot internal components.



TROUBLE	POSSIBLE CAUSE	POSSIBLE REMEDY
Error Code "E1"	The temperature sensor on the discharge pipe may be faulty and may need to be changed.	Contact the customer service center
Error Code "E2"	Heat exchanger may be faulty and may need to be changed.	Contact the customer service center
Error Code "E3"	The room temperature may be too high.	Check to make sure the room temperature is below 90°F. If the room temperature is too high, place the dehumidifier in a location where the room temperature is below 90°F for at least 2 hours before operating again.
Error Code "EH"	The humidity sensor may be faulty and may need to be changed	Contact the customer service center.
Error Code "P1" (Model BDT50PWTB)	Bucket is not in the proper position.	Make sure the bucket is in place and securely seated for the dehumidifier to operate. If error code reappears after adjusting the bucket, please contact the customer service department

Warning

This content is compiled from multiple sources and is provided for reference purposes only. It may not be complete or fully applicable to all situations. If you are unable to resolve your issue, please contact the product manufacturer or an authorized service provider for official support.

