

Guide to the Rotary Iron

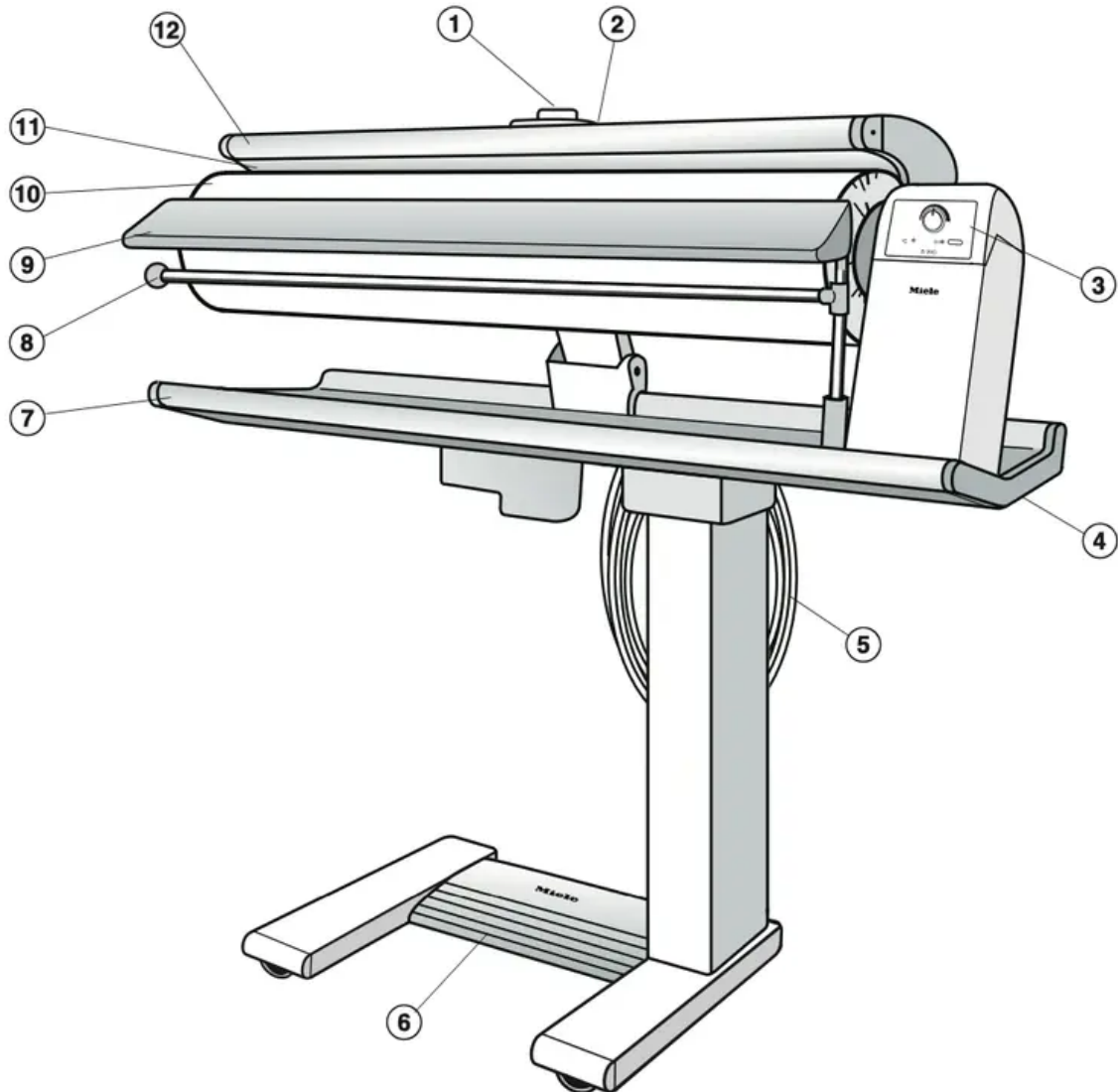

1. Temperature selector
2. Emergency release
3. Control panel
4. Release catch
5. Power cord
6. Foot pedal
7. Ironing table
8. Bar for hanging ironed laundry
9. Feed board

- 10. Roller (with ironing cover)
- 11. Heater plate
- 12. Finger guard

Control panel

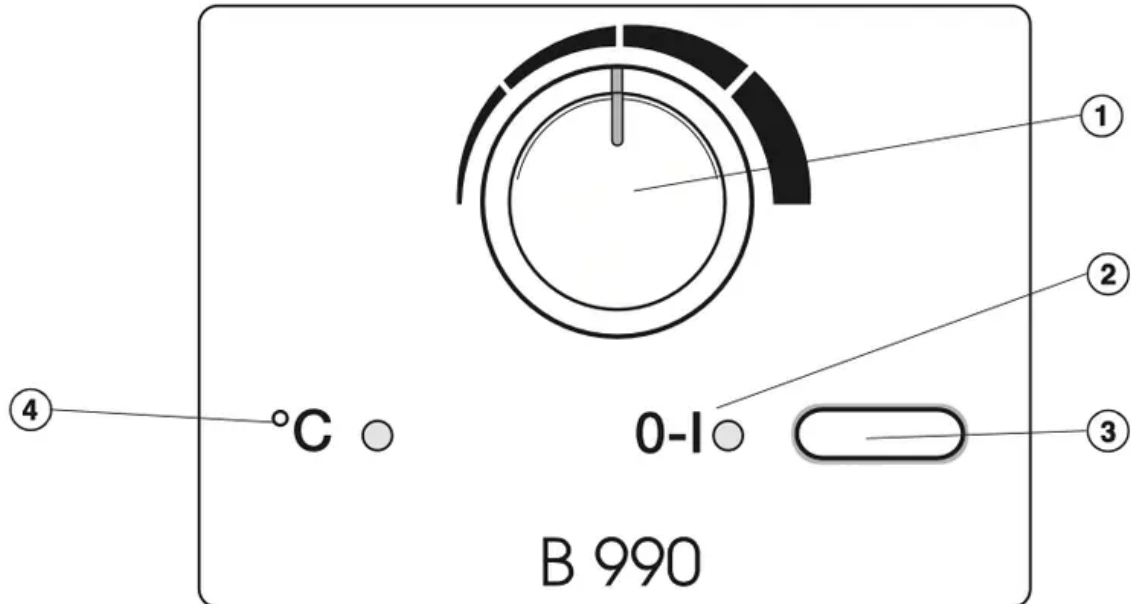

- 1. Roller speed selector
- 2. On-Off indicator "0-I"
- 3. On-Off button "0-I" for turning the rotary iron on and off
- 4. Temperature indicator °C

Moving the appliance

Transport strut

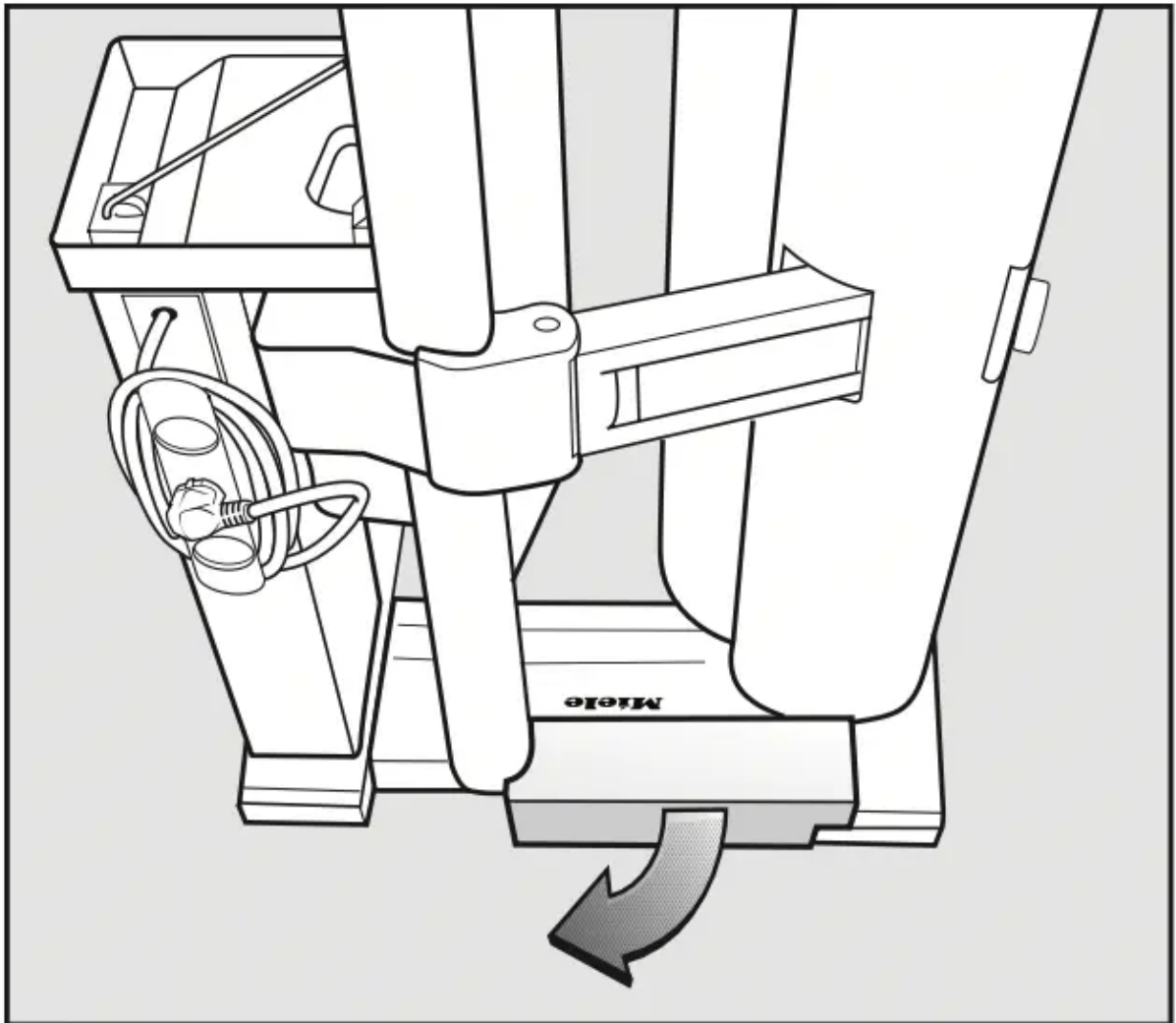

- Pull the transport strut out (see illustration).

Keep the transport strut in a safe place. It must be re-fitted if the appliance has to be moved again (e.g. when moving to a new home).

If the transport strut is in place, only transport the rotary iron in a folded position.

Moving the appliance

The rotary iron has four rollers.

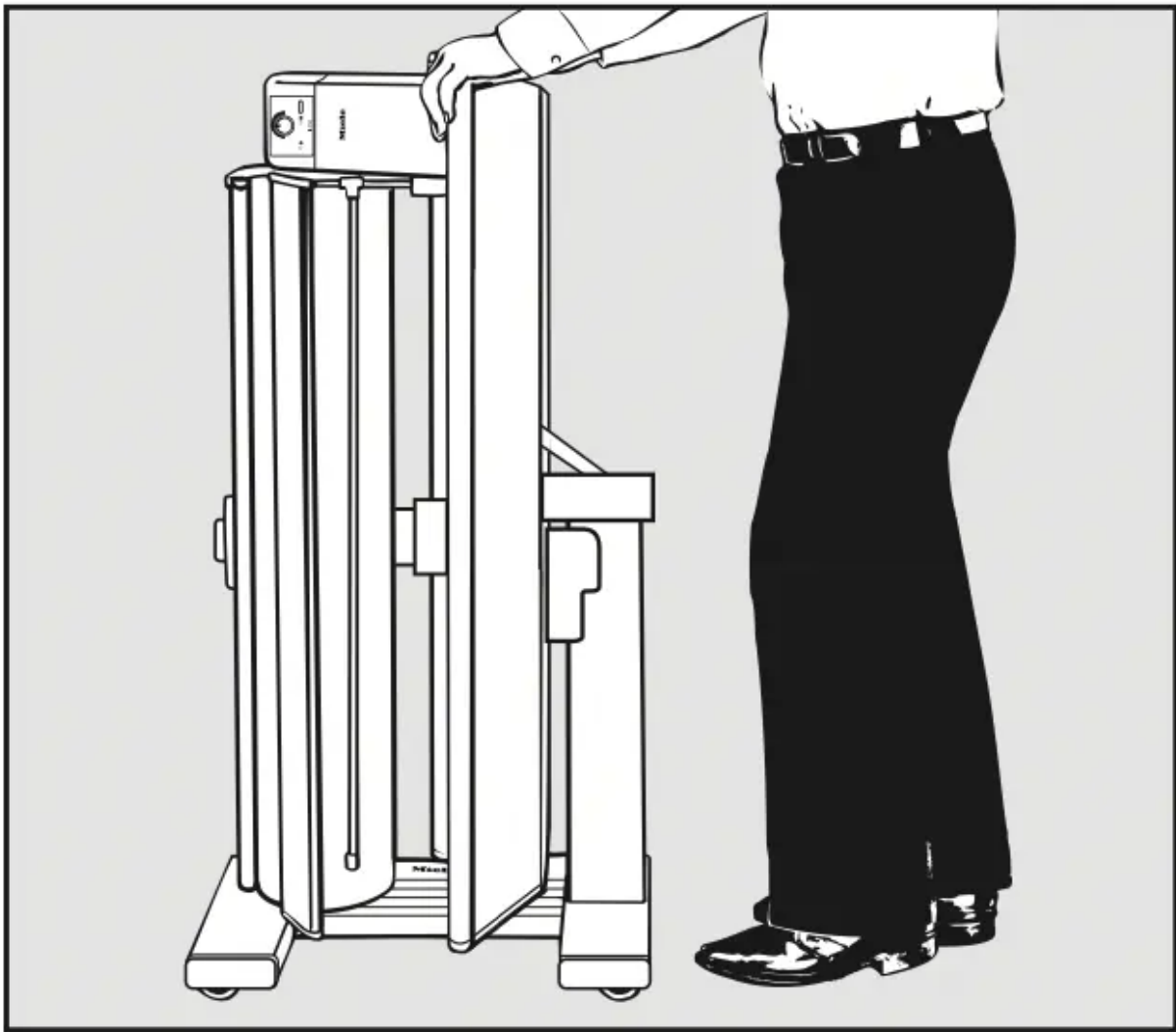

- Hold the rotary iron with the ironing table and push or pull to move it.

To steer and to overcome obstacles like carpet edges and doorways:

- Slightly tilt the appliance.

The rotary iron can be moved either when assembled or folded.

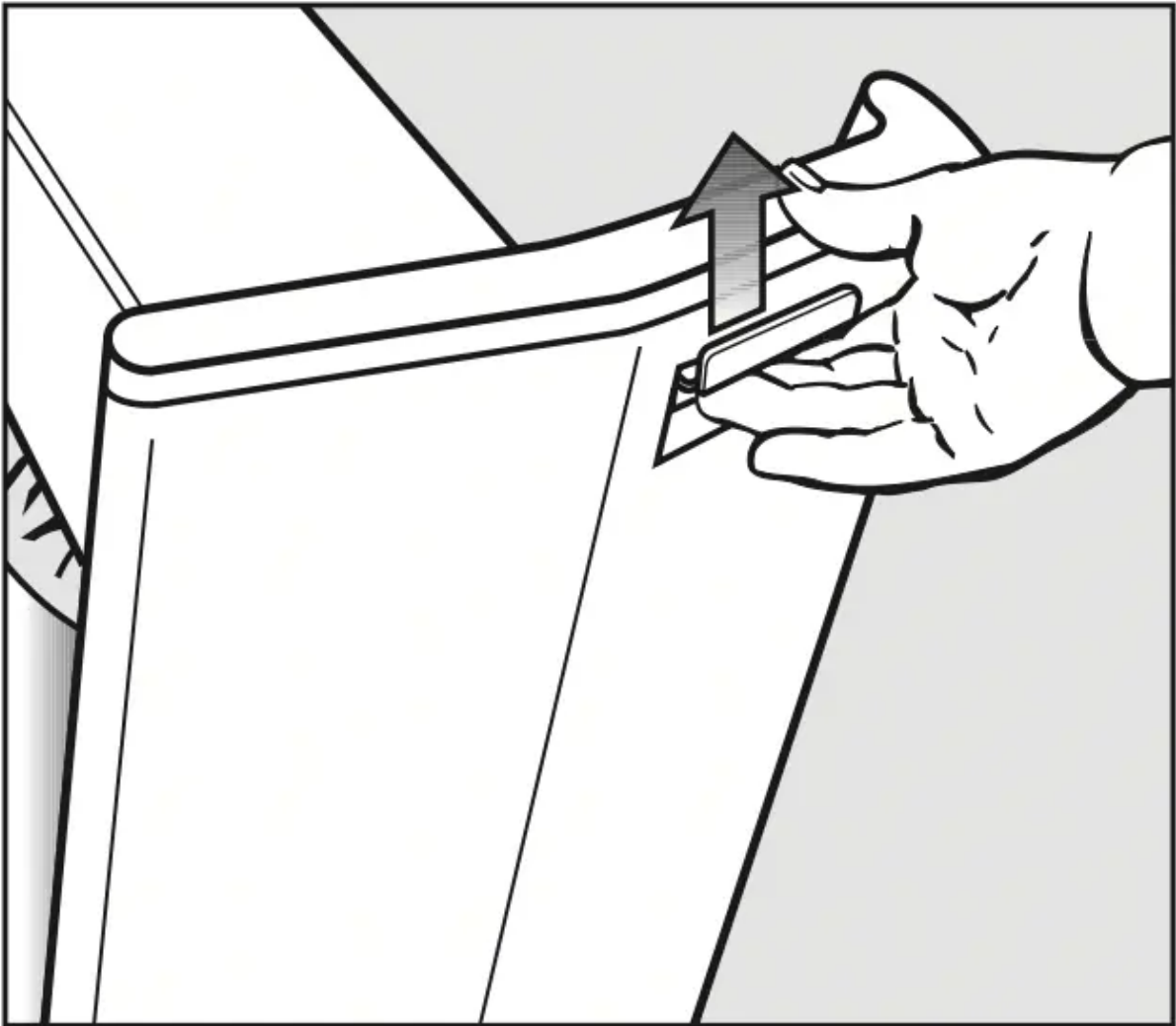

- Hold the ironing table and release the catch, located on the right hand side at the back, underneath the ironing table.

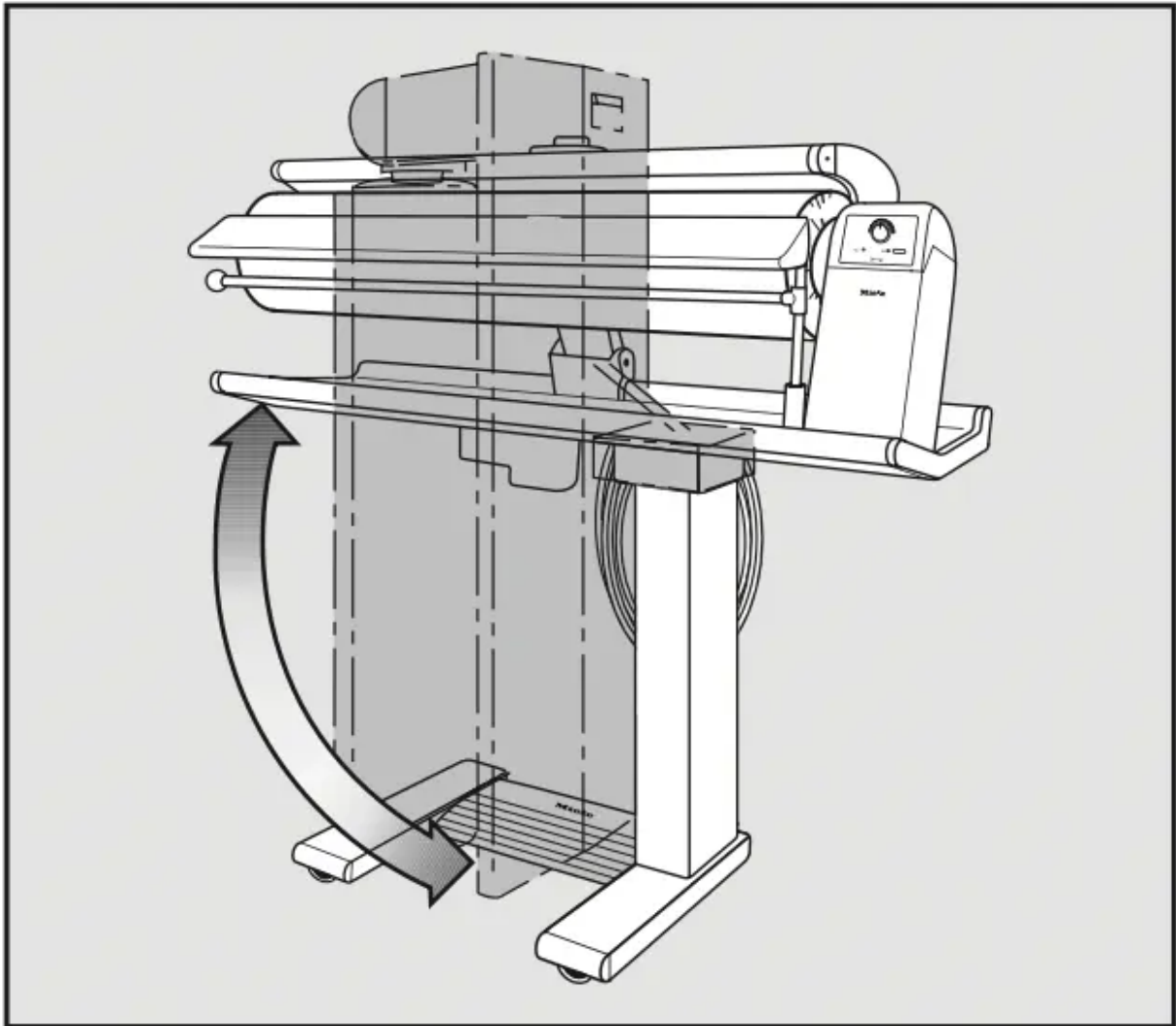

- Swing the top section of the rotary iron to the side until it clicks horizontally into position.

Before using for the first time

Power cord

The power cord is wound around a hook underneath the ironing table.

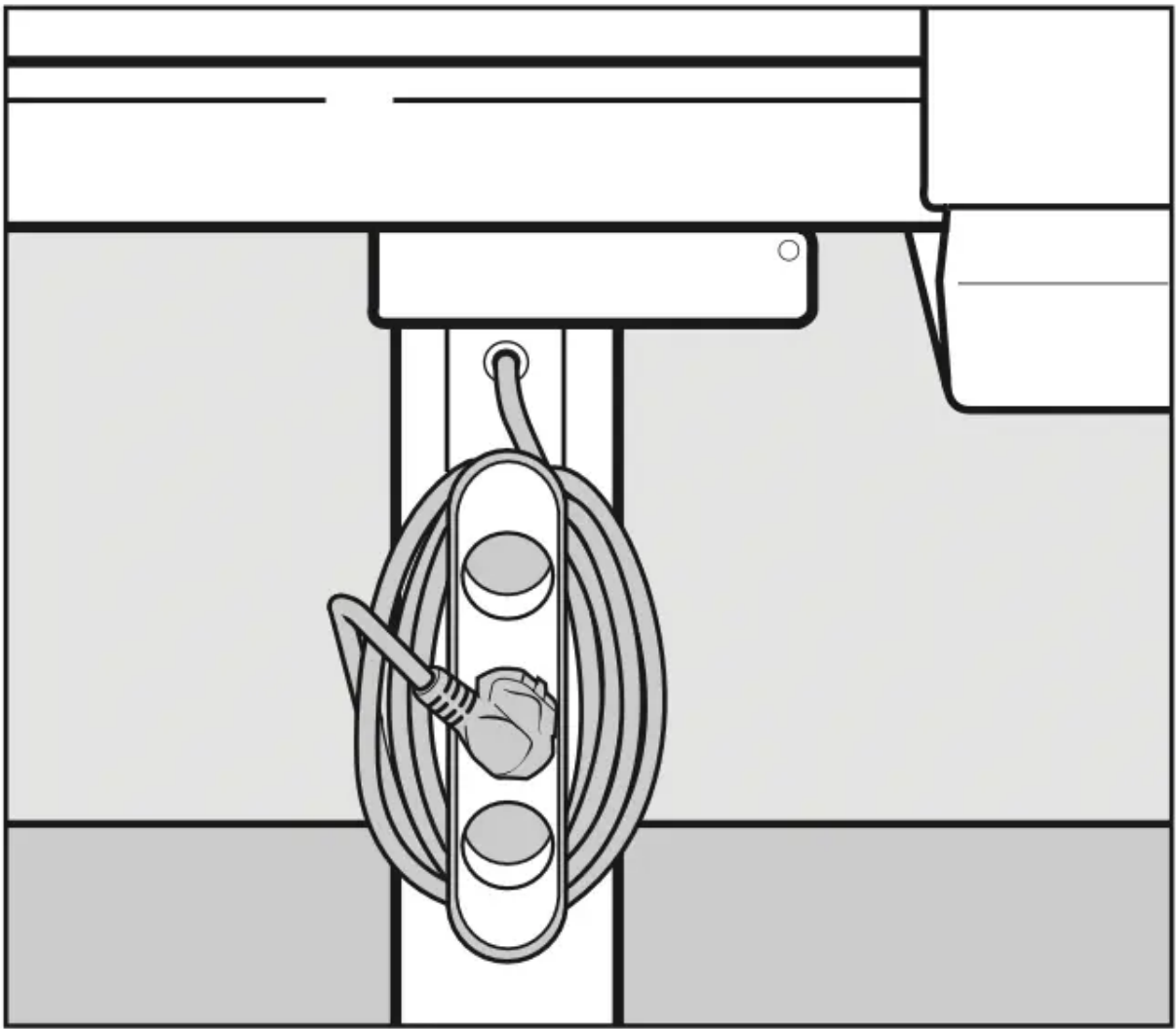

- Unwind the cord.

Warning: Do not insert the plug into the electrical socket yet.

* The plug shown is for illustration only.

Dust cover

The dust cover which protects the roller during transportation must be removed.

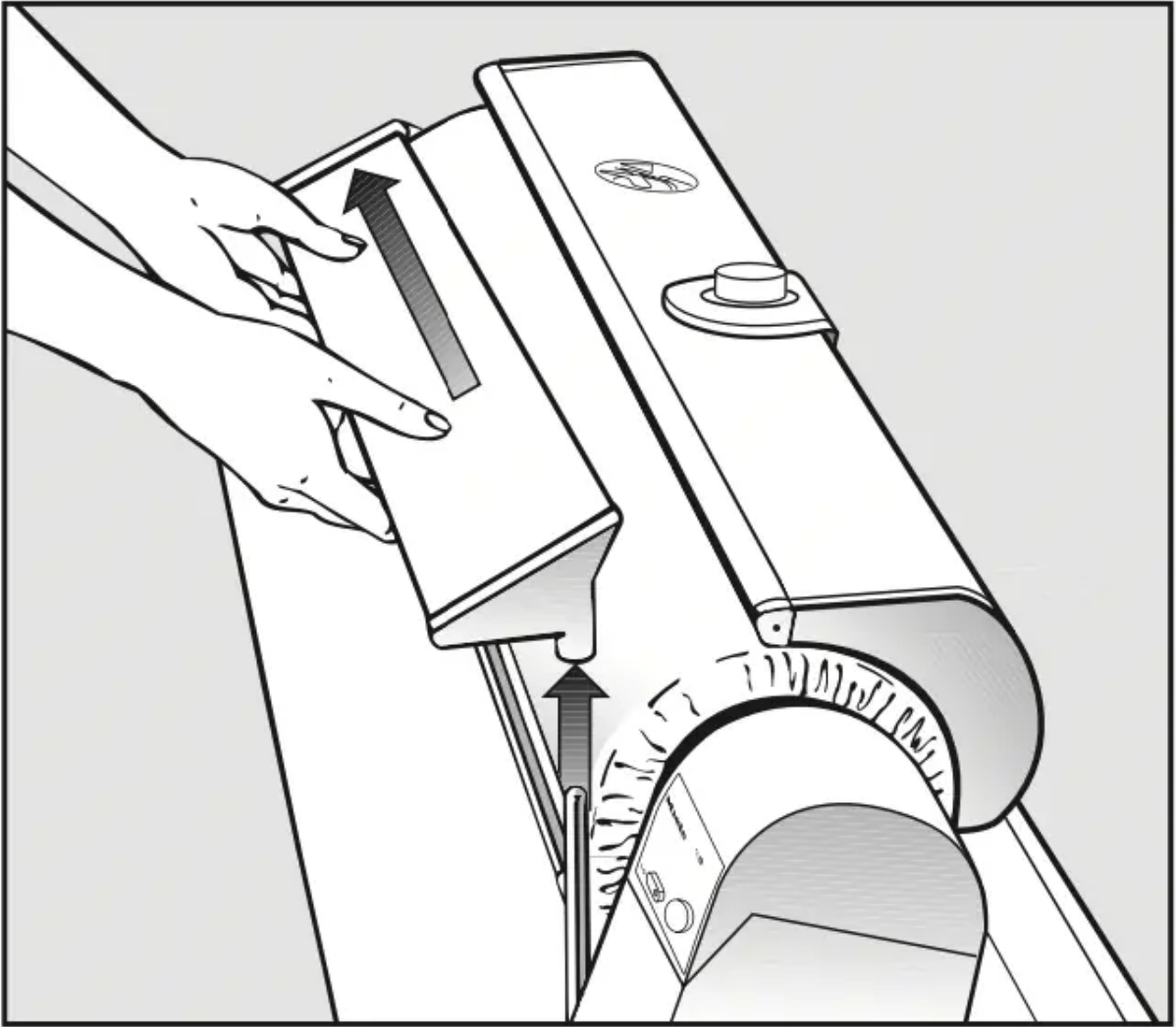

- First remove the feed board by lifting it out of the right hand holder, then pull it out to the left of the roller.
- Plug the appliance in and turn it on.
The heater plate will rise automatically.

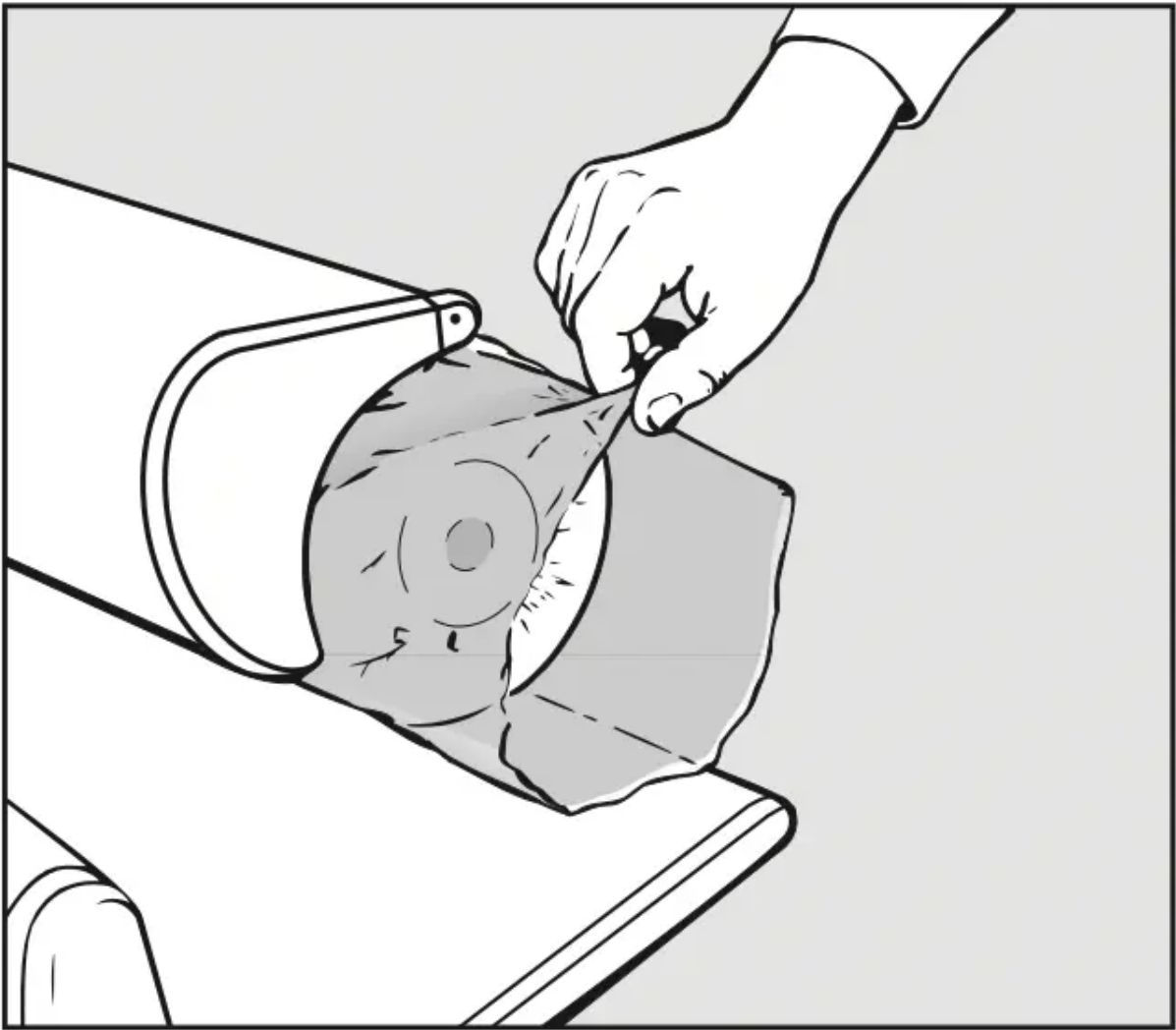

- The protective dust cover can now be pulled off.

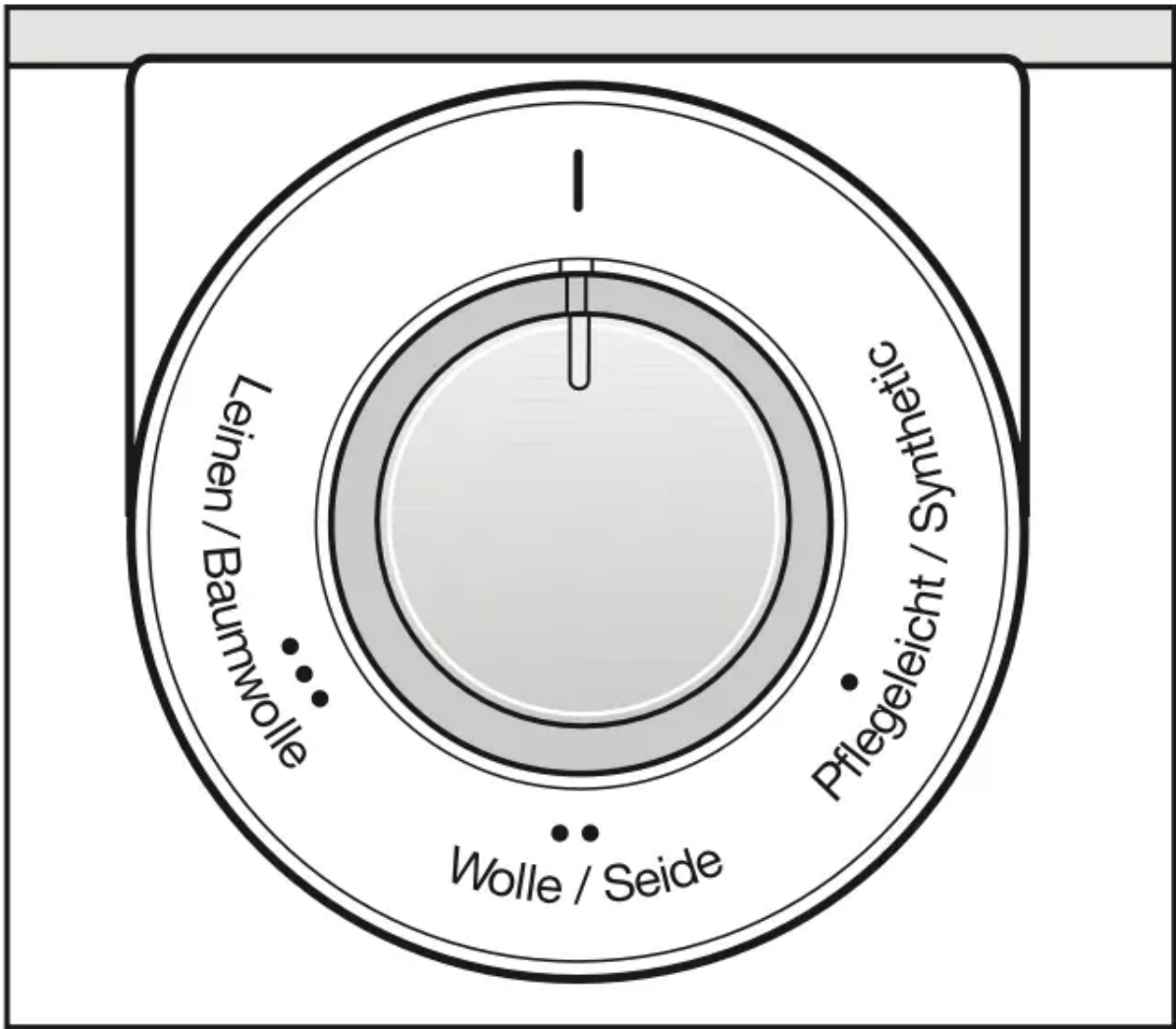

- Adhere the sticker (included) to the temperature control, as shown above.

Before ironing

Preparing the work area



A height adjustable chair and a flat surface, like a table to lay ironed laundry on, are useful.

When positioning the rotary iron horizontally be sure to secure the appliance so that it does not roll.

Place close by:

- a basket with the laundry ready for ironing to the left of the rotary iron,
- a surface for the ironed laundry to the right of the rotary iron.

Shirts, overalls, blouses, etc., should be hung on hangers immediately after ironing.

Small items can be hung over the swing out bar.

Have some water ready to re-dampen the laundry if necessary.

Preparing the laundry

Correct preparation of the laundry is essential for easy ironing.

Before ironing, the laundry should be:

- dampened
- pulled into shape and smoothed out
- sorted.

Correct dampness

The laundry needs to be sufficiently damp, so that on the first pass through the rotary iron at the correct temperature, it will come out smooth and dry. Dampen the laundry as you would for hand ironing, preferably several hours beforehand so that the articles achieve a uniform degree of dampness throughout.

If a tumble dryer is being used, select a "Machine iron" program.

- If preparation time is short use warm water to re-dampen.

Material	Dampness for ironing
Silk	wrap in a damp cloth to avoid water marks
Synthetics e.g. Nylon, Polyester, etc.	slightly damp to dry
Wool e.g. pants	press under a damp cloth
Cotton	slightly damp
Linen	quite damp

Pulling into shape and smoothing out

- Pull the dampened laundry into shape as usual.
- Smooth out ribbons, straps, seams and hems.

- Large items such as table cloths, bed linens, etc. should be folded lengthways into a number of pleats so that they can be ironed as easily as possible.

Sorting

- Sort the laundry according to how much heat is required for ironing.

Start ironing at a lower temperature and gradually increase the temperature according to the fabric being ironed.

Minimum Iron (Perlon, Nylon, etc.) ●

Woolens, Silk ●●

Cottons, Linen ●●●

- Iron starched items last to avoid any starch deposits on other items.

Testing the finger guard

The finger guard is a safety feature and should be checked each time the rotary iron is used.

- With the rotary iron turned on, press the foot pedal down.

The heater plate comes down onto the rotating roller.

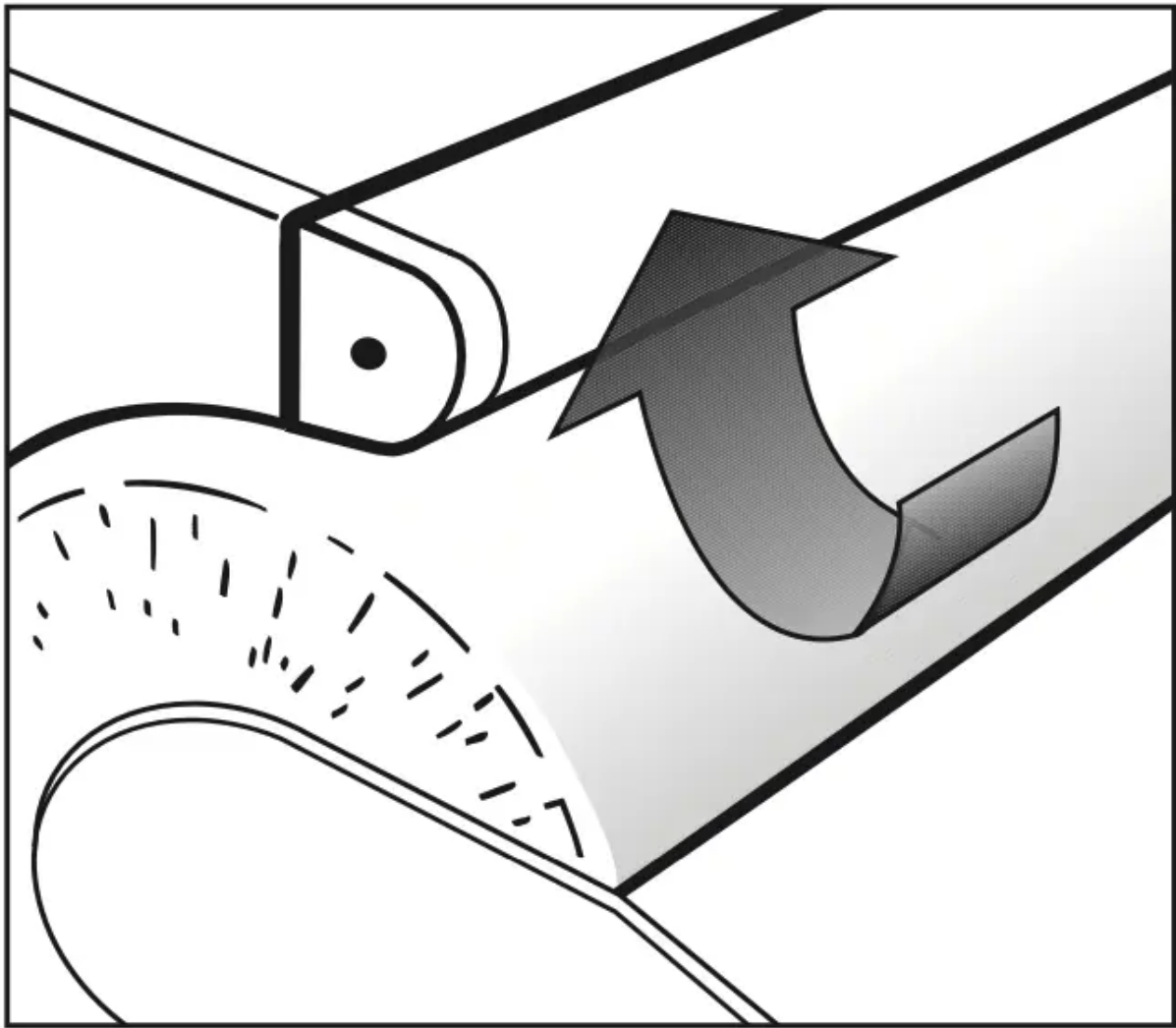

- If you lift the finger guard now, the roller stops rotating and the heater plate rises.

This shows that the finger guard is working.

- Let go of the finger guard and remove your foot from the foot pedal.
- Press the foot pedal down again.

The heater plate lowers and the roller rotates.

Please note:

Any unevenness in the ironing cover will smooth itself out after 3 hours of use.

When using a new machine, if delicate laundry is not properly pulled into the rotary iron continue ironing. This is usually solved after 5-10 minutes of ironing.

If a new ironing cover is used, wash the cloth at a high temperature (140°F/ 60°C) to achieve an optimal pull-in of the laundry.

Ironing

Turning on and off

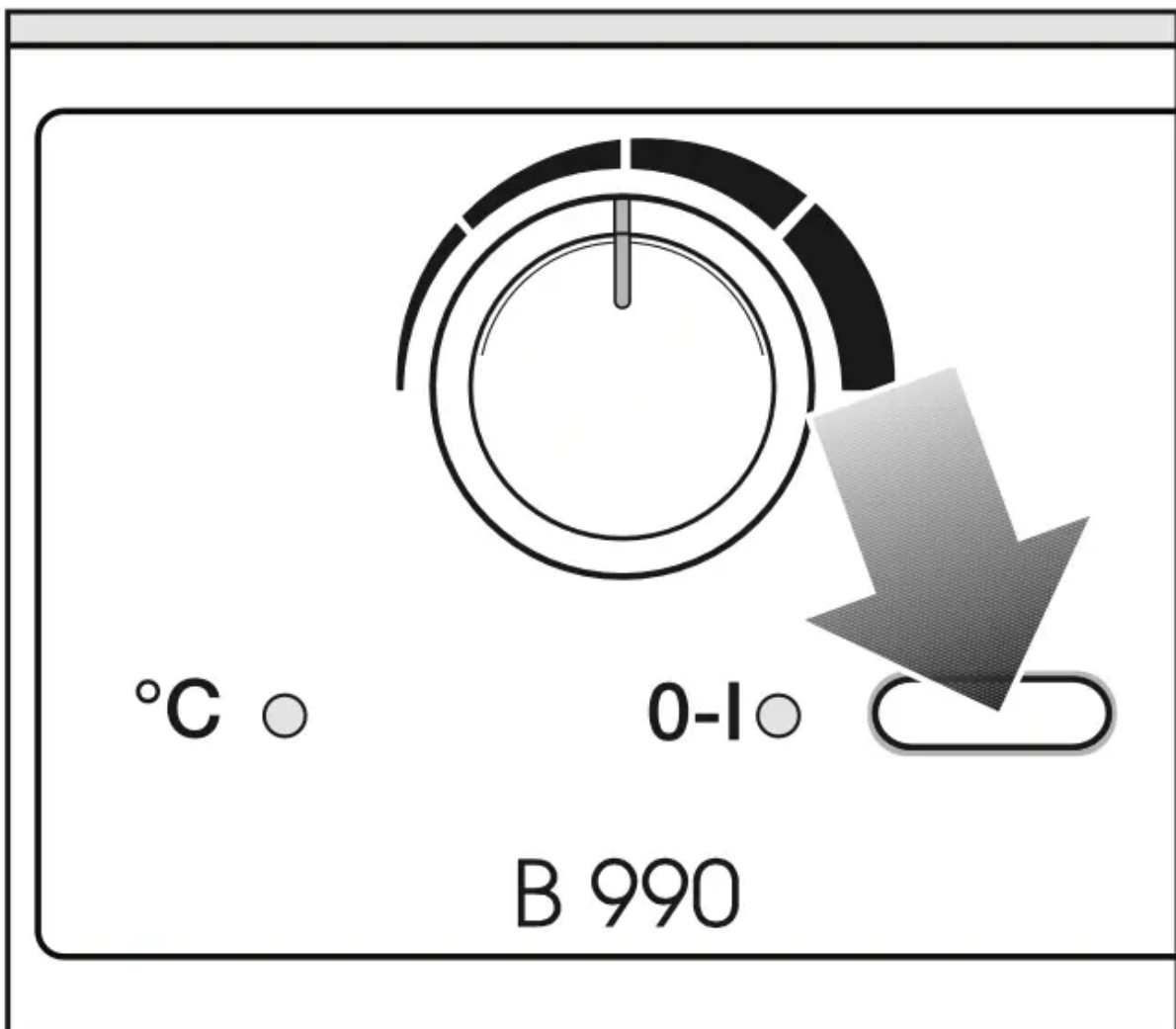

The rotary iron is turned on and off with the "0-I" button.

To turn on

- Press the button in.

The indicator light comes on.

To turn off

- Press and release the button.

The indicator light goes out.

Selecting the ironing temperature

The temperature selector is used to set the ironing temperature.

The temperature range is marked by dots on the ring around the temperature selector. These correspond with the international fabric care symbols for ironing.

Material	Dot Symbol	Temperature range
Minimum Iron	●	cool iron (low temperature)
Woolens	●●	medium hot iron (medium temperature)
Cottons	●●●	hot iron (high temperature)
	I	104 - 140 °F (40 - 60 °C)

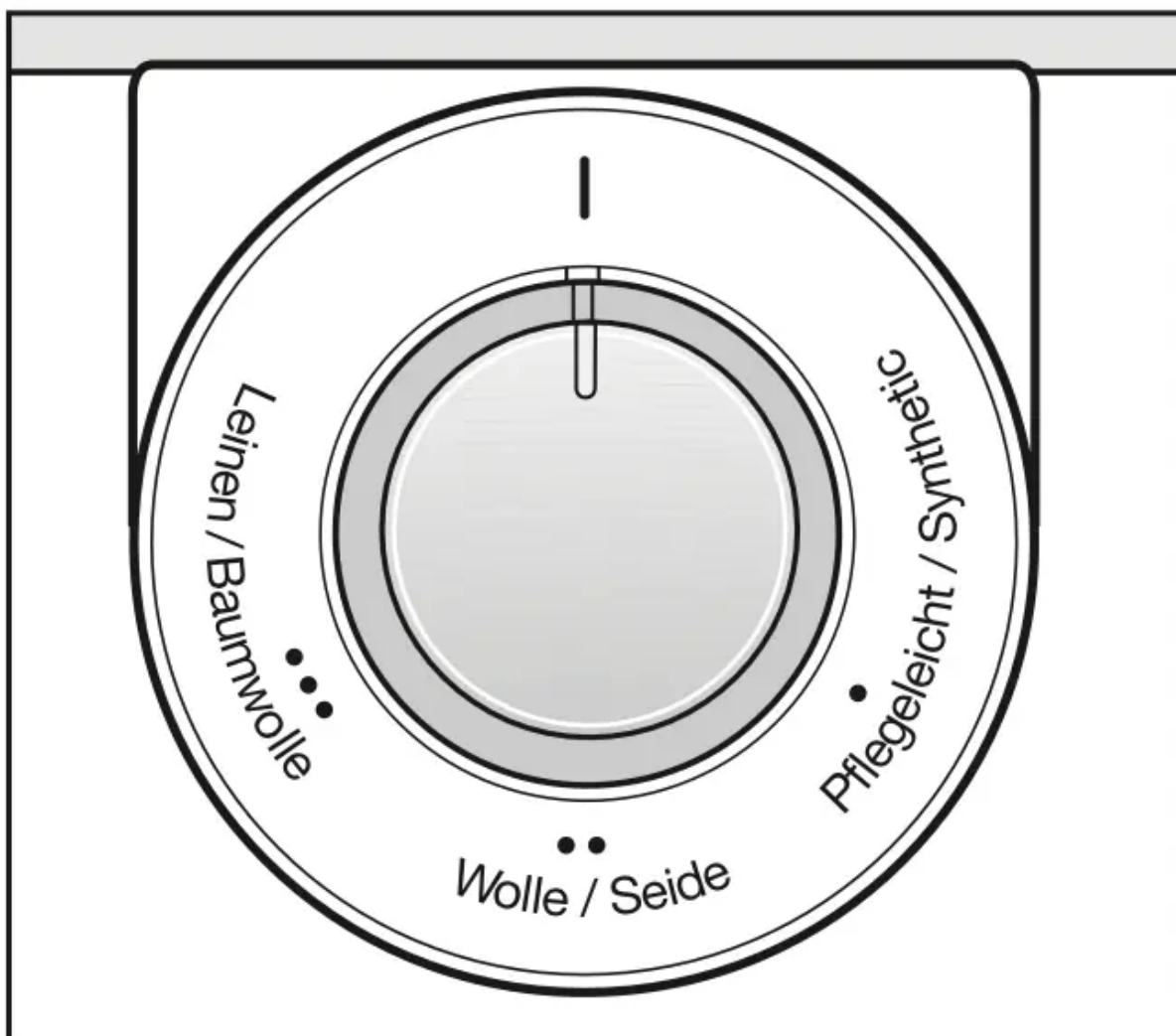

- Turn the temperature selector to the desired temperature.

The temperature "C°" indicator will light while the heater plate is heating up. The light will go out when the temperature selected is reached.

When ironing a fabric blend, e.g. poly cottons, the more delicate fiber determines the ironing temperature. However, if there is more cotton than polyester, the item can be ironed on the Woolens setting.

Do not use the cotton setting.

Selecting the roller speed

There are 5 roller speed settings, from low (approximately 6.5 ft/min.[2 m/min]) to high 15 ft/min. [4.5 m/min]).

A lower roller speed makes it easier to iron complicated articles such as shirts and blouses. It is also best to select a low roller speed when ironing folded items, which may require more than one pass through the rotary iron to get them smooth and dry.

Thinner, single thickness items, e.g. handkerchiefs can be ironed at a higher roller speed.

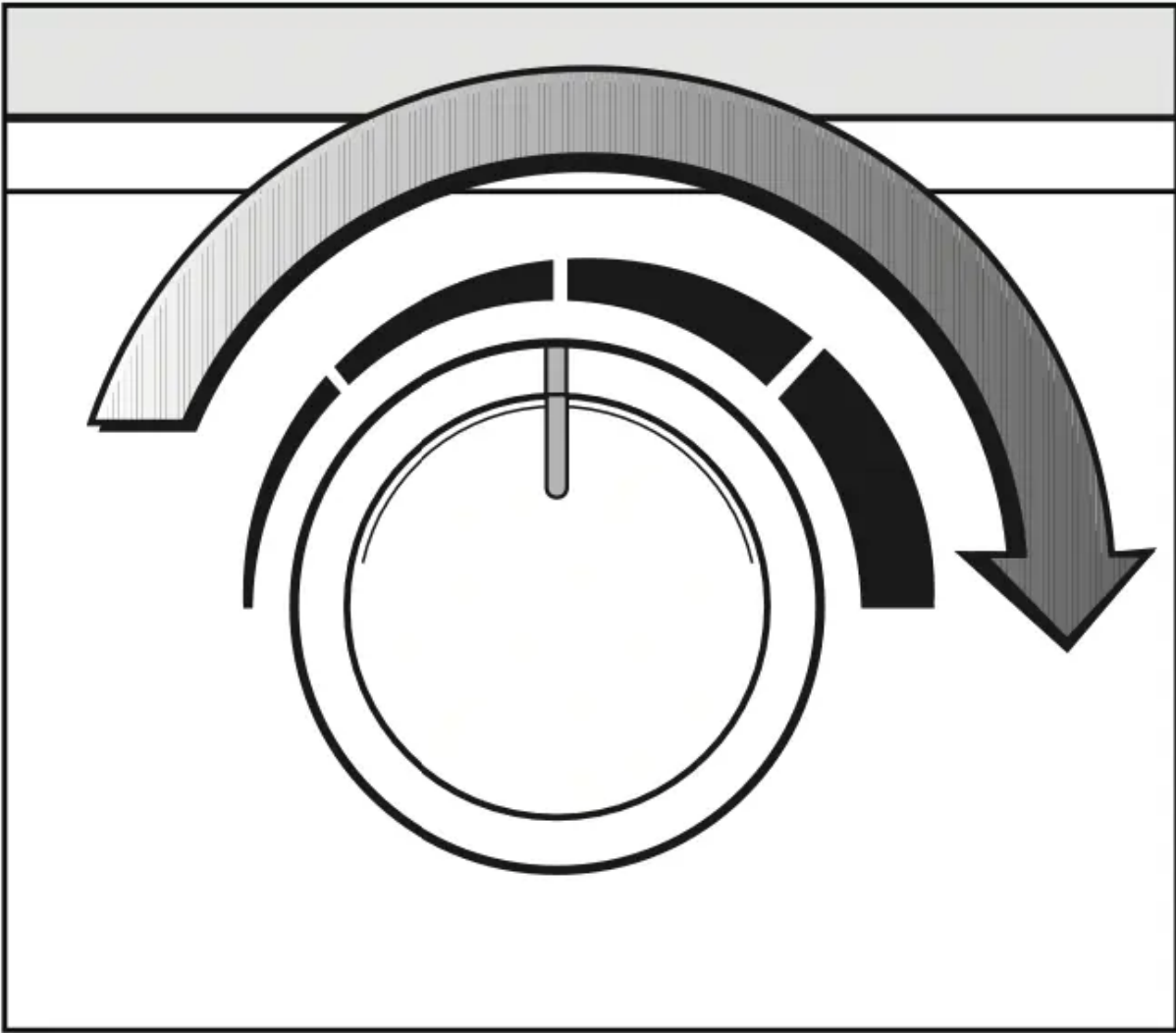

- Set the roller speed selector to the desired speed.

Ironing

The ironing process is controlled by the foot pedal which has three operating positions:

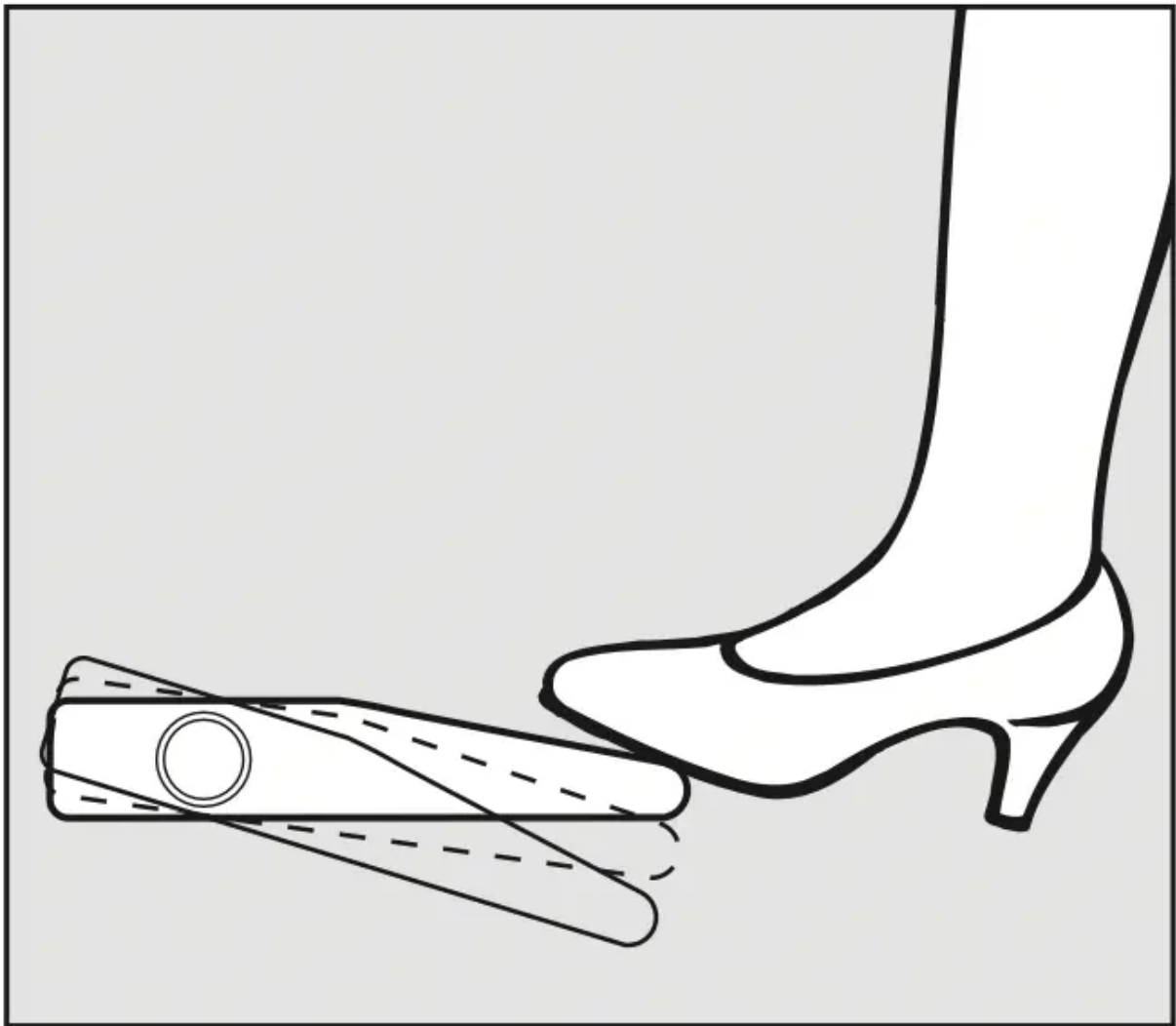

- raising the heater plate (rest)
- pressing
- ironing

To iron

- Press the foot pedal down to the floor.

Warning: Do not put fingers between the heater plate and the roller. Danger of burning and injuring fingers.

To press

- First press the foot pedal down to the floor and then lift your foot up a little so that the heater plate remains in position but the roller does not rotate.

To raise the heater plate

- Take your foot off the pedal.

Positioning the laundry

- Arrange the laundry items on the feed board so that they are straight and then smooth out.

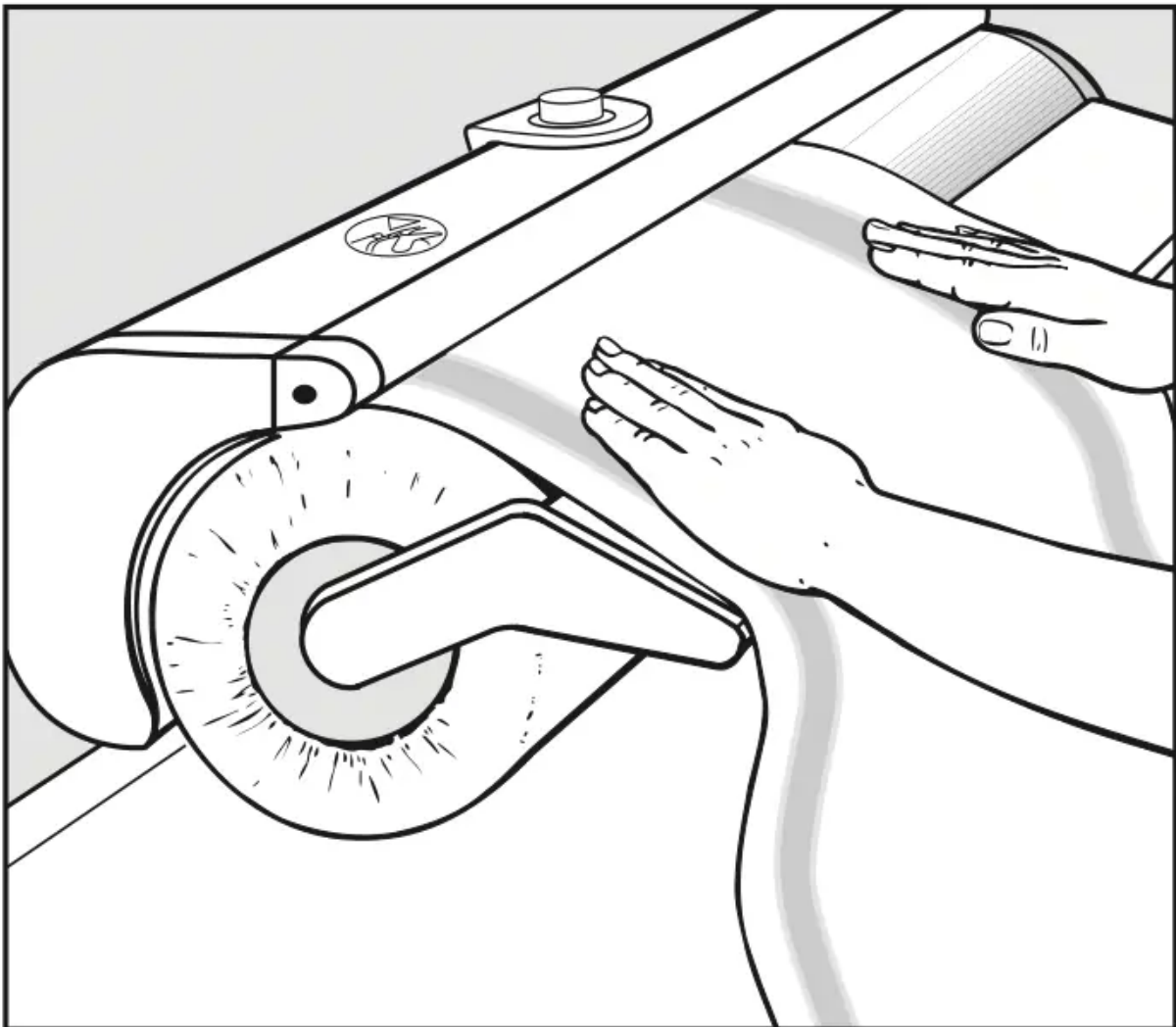

- Then turn the roller by hand, always keeping your hands away from the heater plate, so that the edge of the item to be ironed can be held by the heater plate.
- Press down the foot pedal.

Removing the feed board

The feed board can be removed when shaped garments are being ironed, e.g. skirts (round).

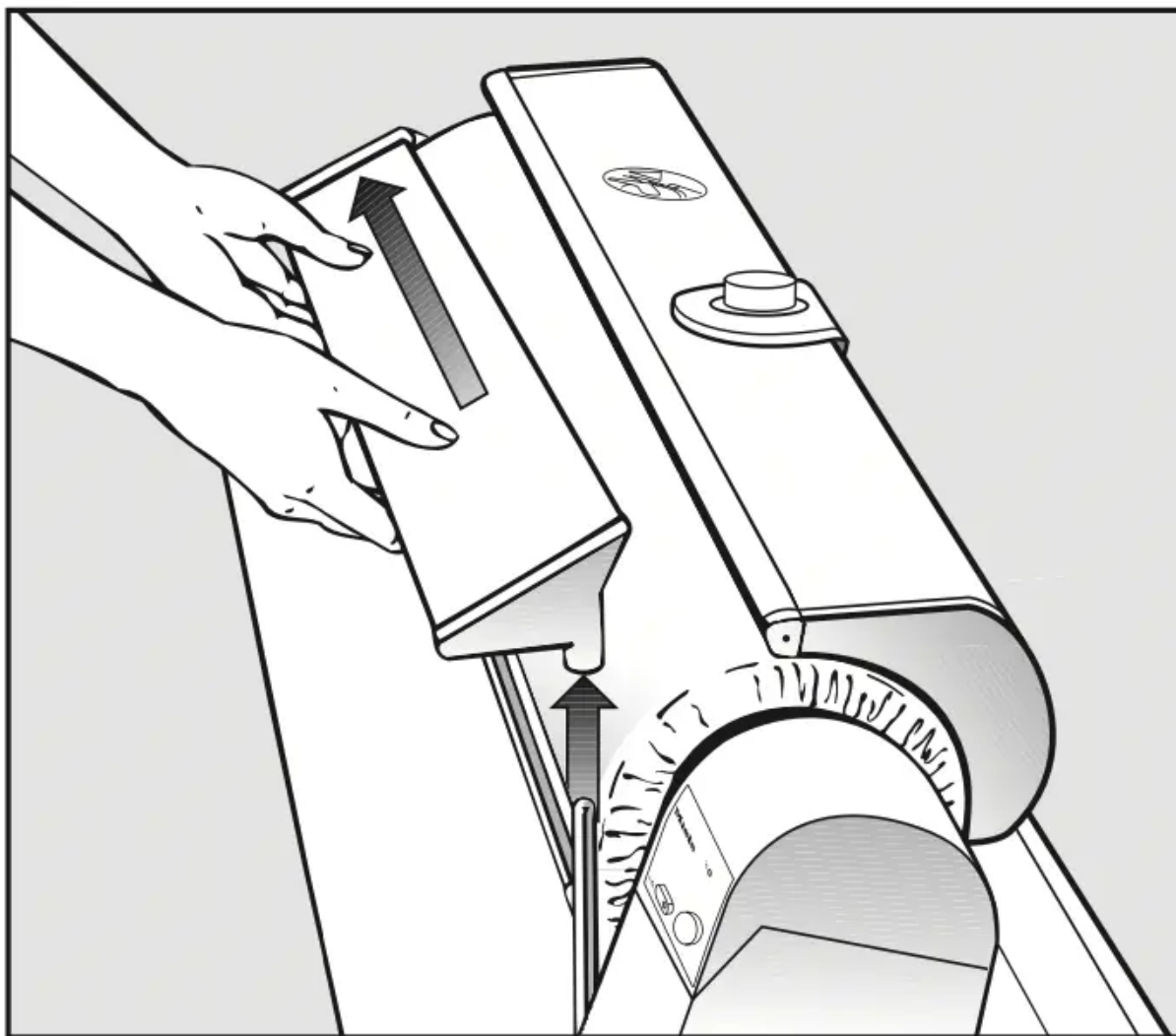

- Lift the feed board out of the right hand holder and then pull it out to the left of the roller.

Laundry bar

Ironed laundry can be hung over the swing out bar to avoid creasing.

Warning: Take care not to press down on the bar when it is swung out, this could cause the rotary iron to tip over.

Ironing tips

- To avoid creasing stop the roller, pull the item back slightly and smooth out. If necessary, dampen again with a wet cloth or spray bottle.
- If possible, always use the whole length of the roller, otherwise the roller will lose its elasticity.
- For small items such as handkerchiefs, alternate between using the right and left hand sides of the roller.
- Items with raised buttons should be ironed face down on to the roller so that they are pressed into the cushioned surface.
- Cover zippers, metal buttons, and metal hooks with a cloth to protect the heater plate.

- To protect the heater plate do not iron buttons that are not heat resistant or very large.
- When you have nearly finished ironing you can turn the temperature selector to **I** and continue ironing small items at a low temperature.

After ironing

- Turn the appliance off.
- Turn the temperature to **I**.
- Remove the plug from the outlet.

If the rotary iron is to be stored away

- Allow the heater plate to cool.
- When the heater plate has cooled completely, fold the rotary iron.
- Wind up the power cord.
- Pull the cover on.

Power failure

In the event of a power failure, pull the emergency release lever up.

If there is a power failure when the rotary iron is in use, the heater plate will stay on the roller. The item being ironed will be held there possibly becoming scorched.

To free the trapped item

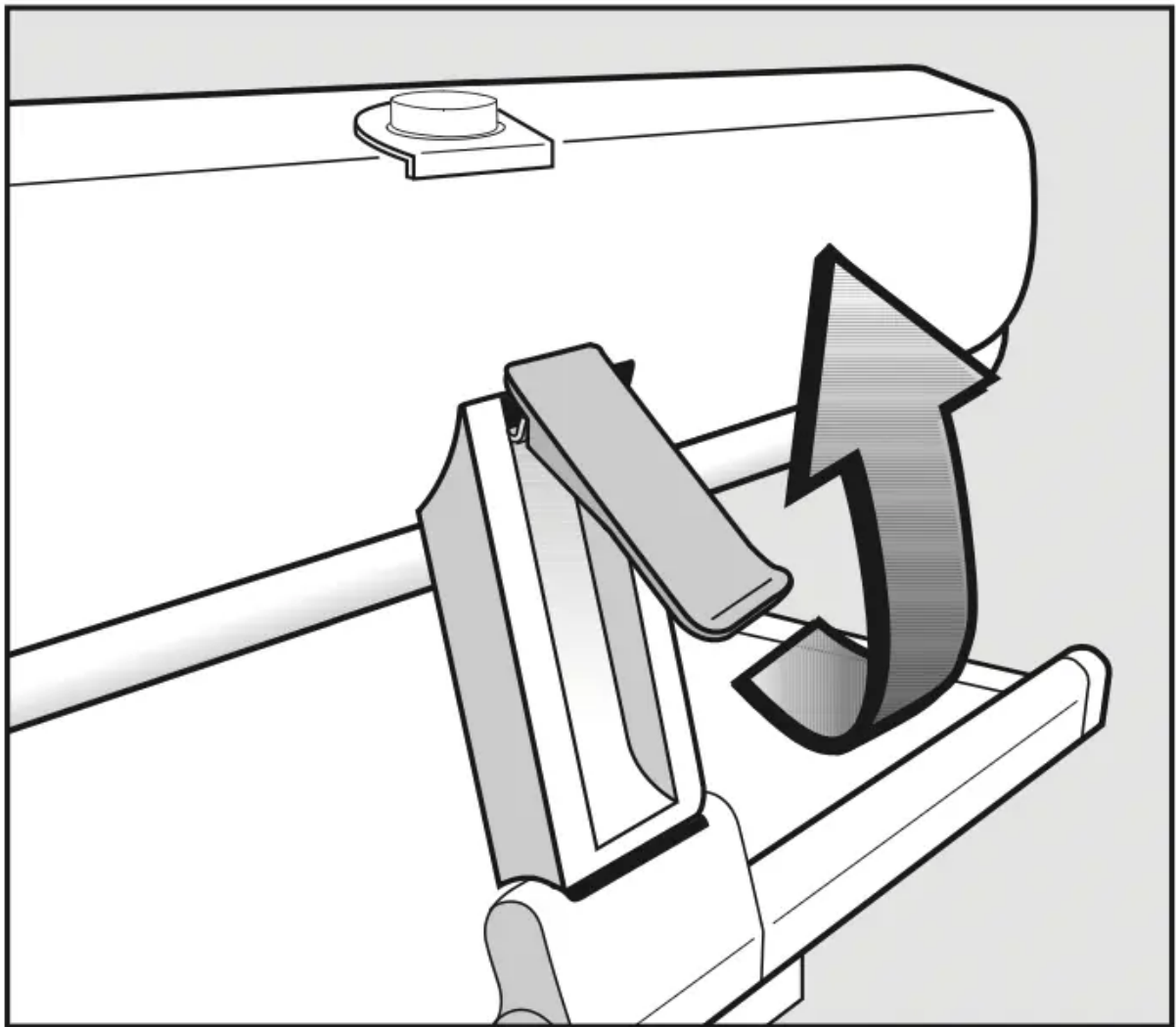

- Pull the emergency release lever up.

The pressure is reduced and the item can be removed.

When power has been restored (the On/Off indicator comes on) push the emergency release lever back down. Continue ironing as usual.

Ironing Tips

Tablecloths

- Avoid folds by ironing the middle first.

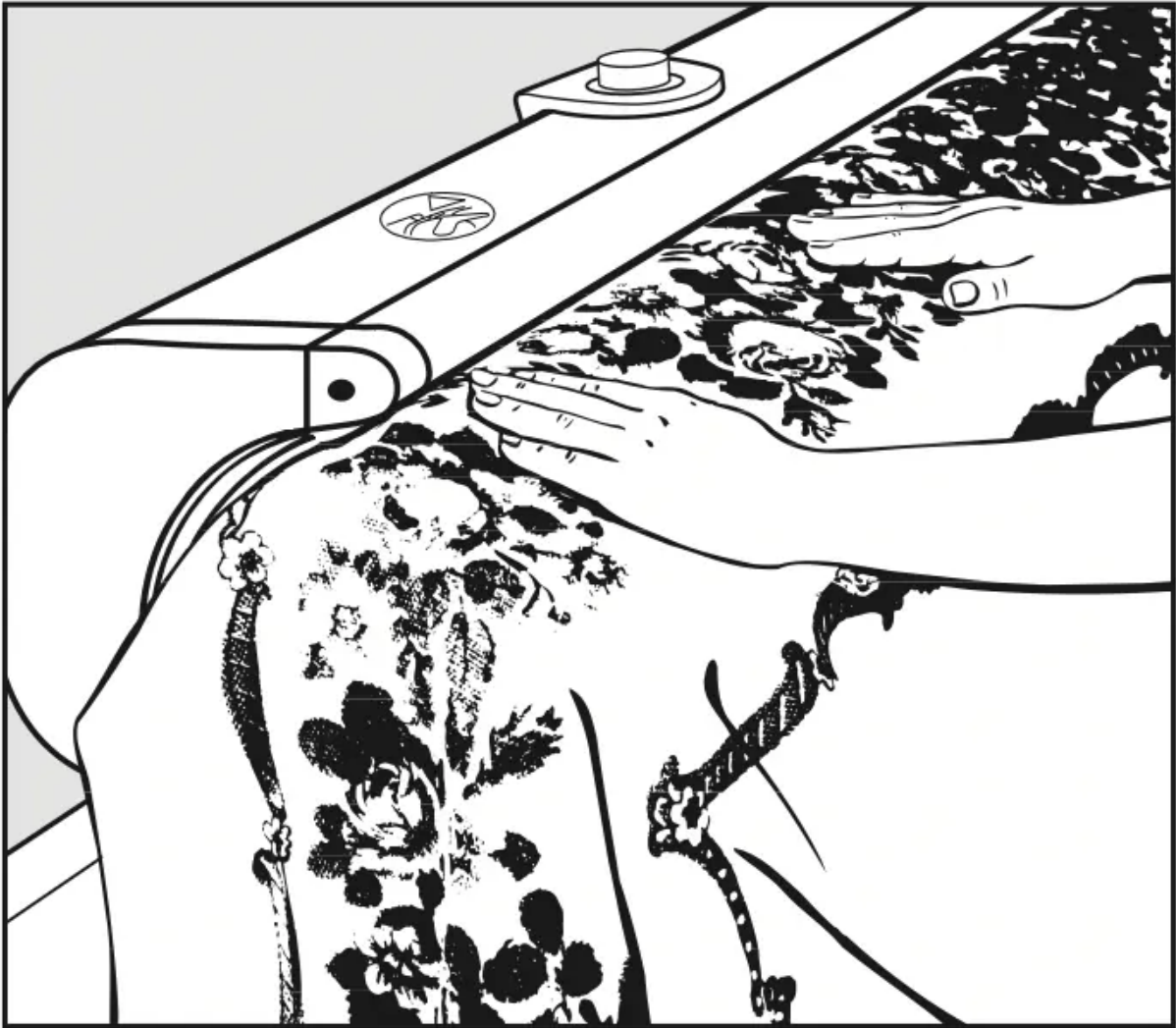

- Place the tablecloth crossways so that the ends hang over to the left and right.
- Iron the middle section.



- Fold in half with unironed edges together and place over the left end of the roller with the ironed middle section hanging over the edge to prevent creasing. Then pass both sides of the non ironed sections through the rotary iron.

Napkins, hand towels

- Lay the item with the straight grain of the fabric to the feed board.

This will prevent it from losing its shape and will be easier to fold.

Pass handkerchiefs diagonally through the rotary iron and, if necessary, fold them and then iron again.

- Please use the whole length of the roller.

Sheets and bedspreads

Sheets may be ironed like tablecloths, or if a lengthwise fold is acceptable, fold the sheet together lengthwise and iron it on both sides.

To accentuate embroidery and raised patterns on bedspreads, iron first in one direction and then in the other.

Pillow cases

- Lay the pillowcase on the feeder plate, position under the heater plate and iron in one step.
- If the open end has buttons, only pass it through the rotary iron if the buttons are heat resistant.

Duvet covers

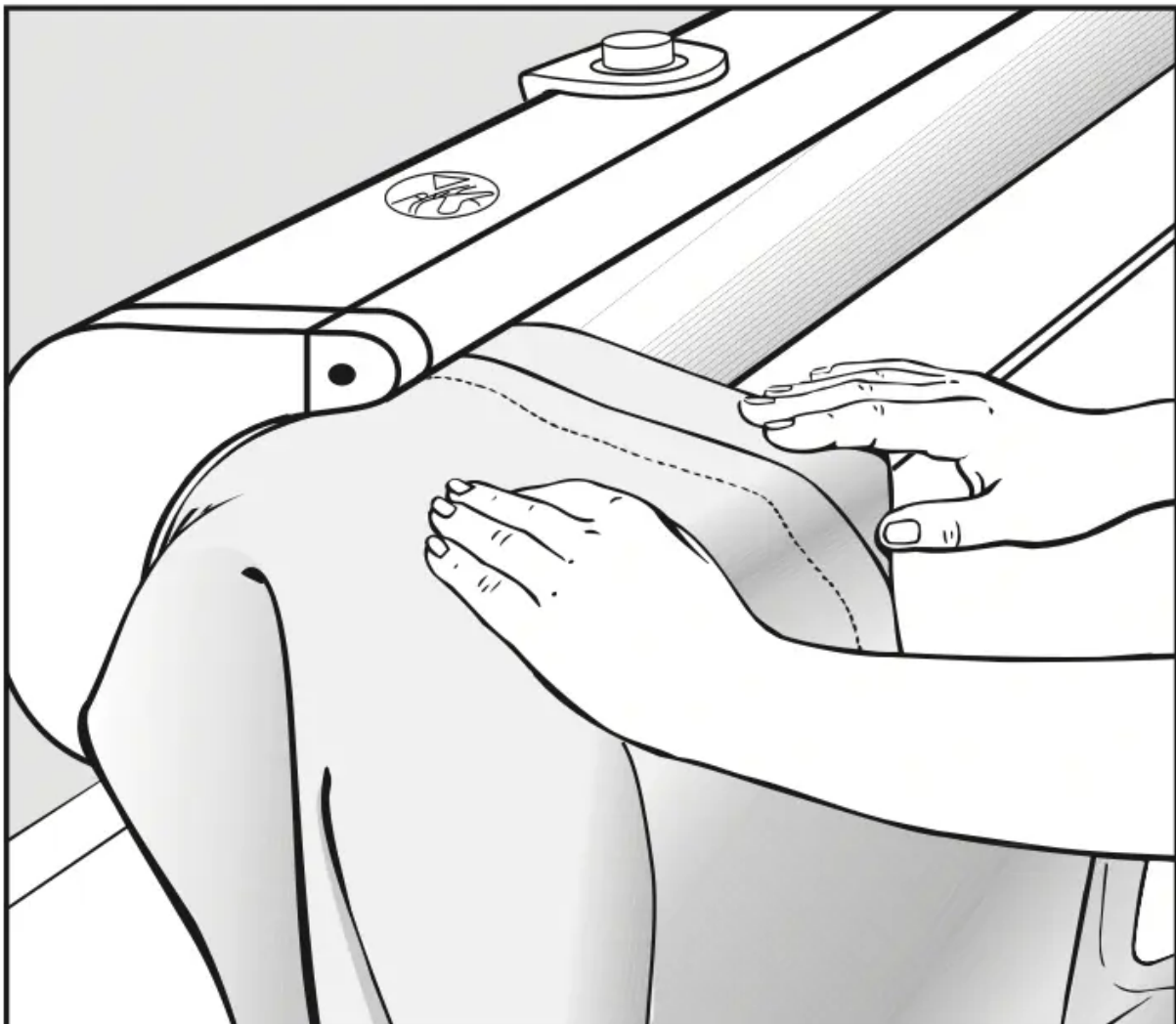

If the duvet cover has buttons at the open end, iron the buttons first.

Note: Only pass this end through the rotary iron if the buttons are heat-resistant.

- Start the first run by carefully feeding this end in first on the left side of the roller, taking care not to damage any buttons.

To iron without a fold

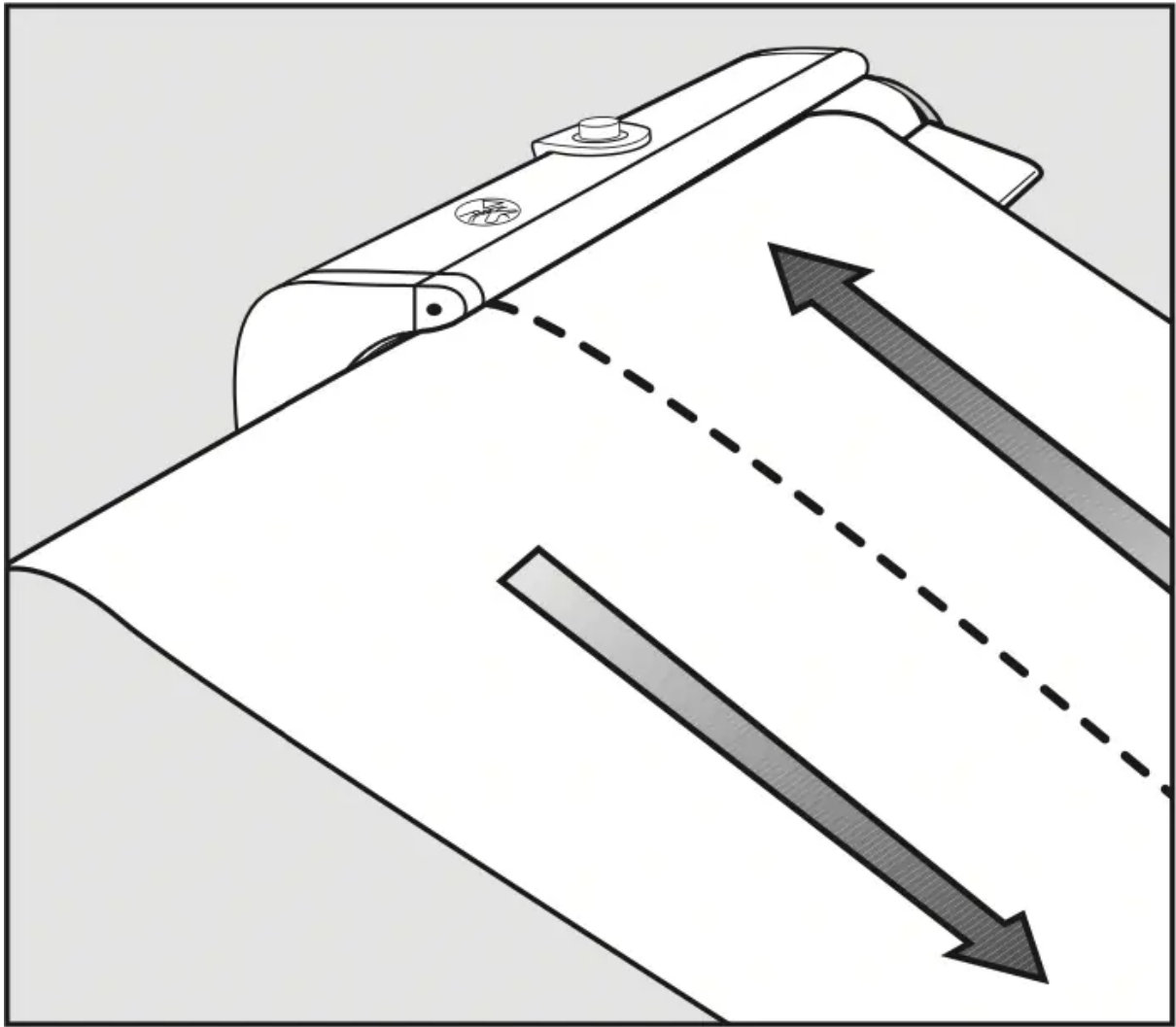

- It is best to iron the cover in two runs lengthwise.

If folds are acceptable

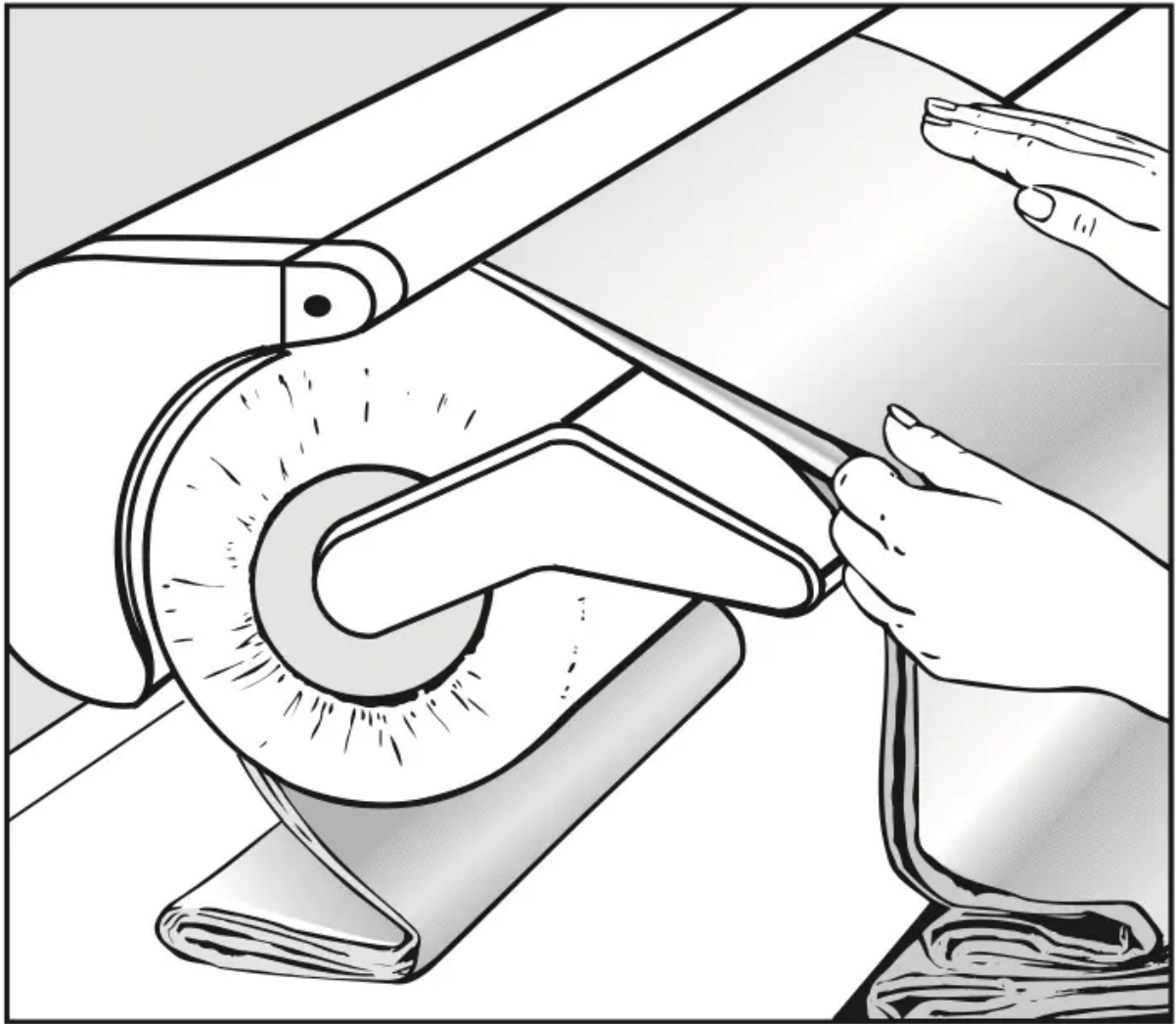

- Fold the duvet cover lengthwise and iron both sides.

Shirts

- Remove the feed board to iron shirts.

1. Shoulder yoke

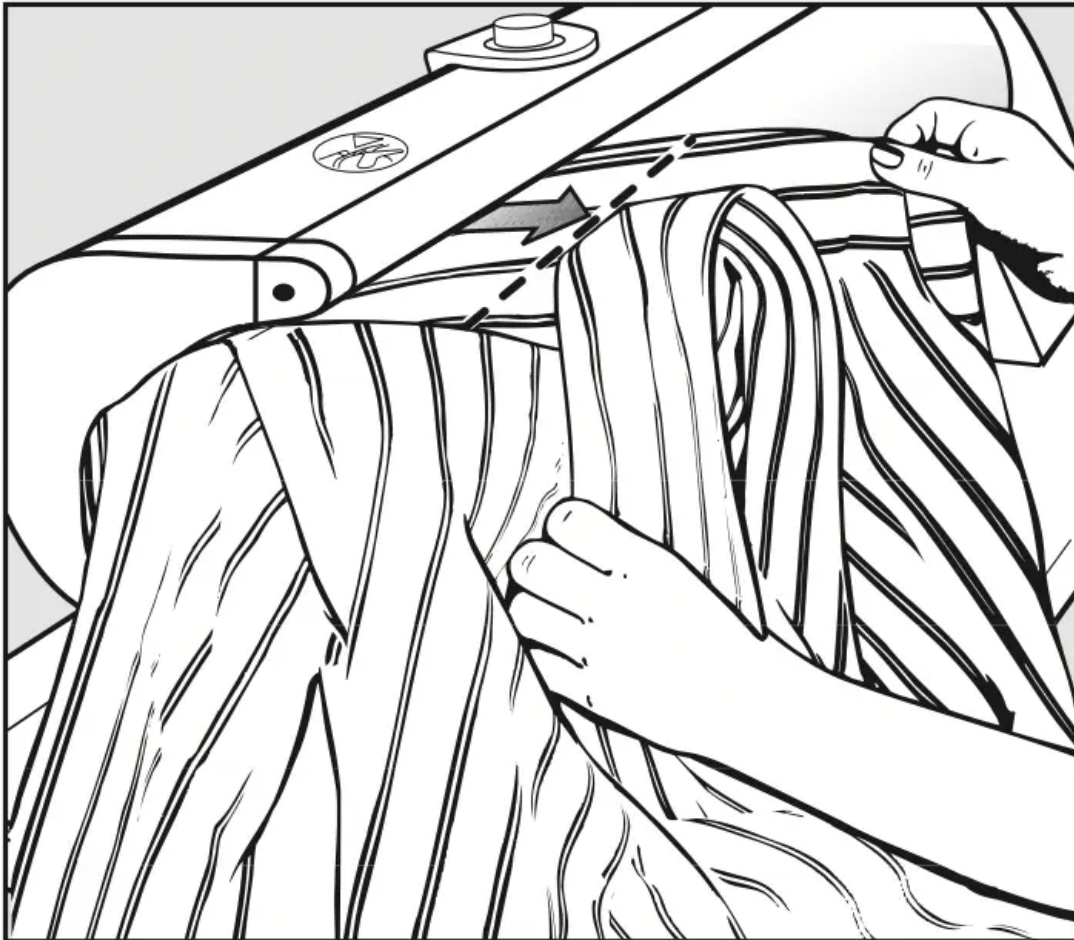

Arrange the yoke, collar first, on the roller and smooth out.
Hot press the yoke.

2. Collar

The collar is ironed on both sides using the left hand end of the roller. Stop ironing when the button comes to the heater plate.

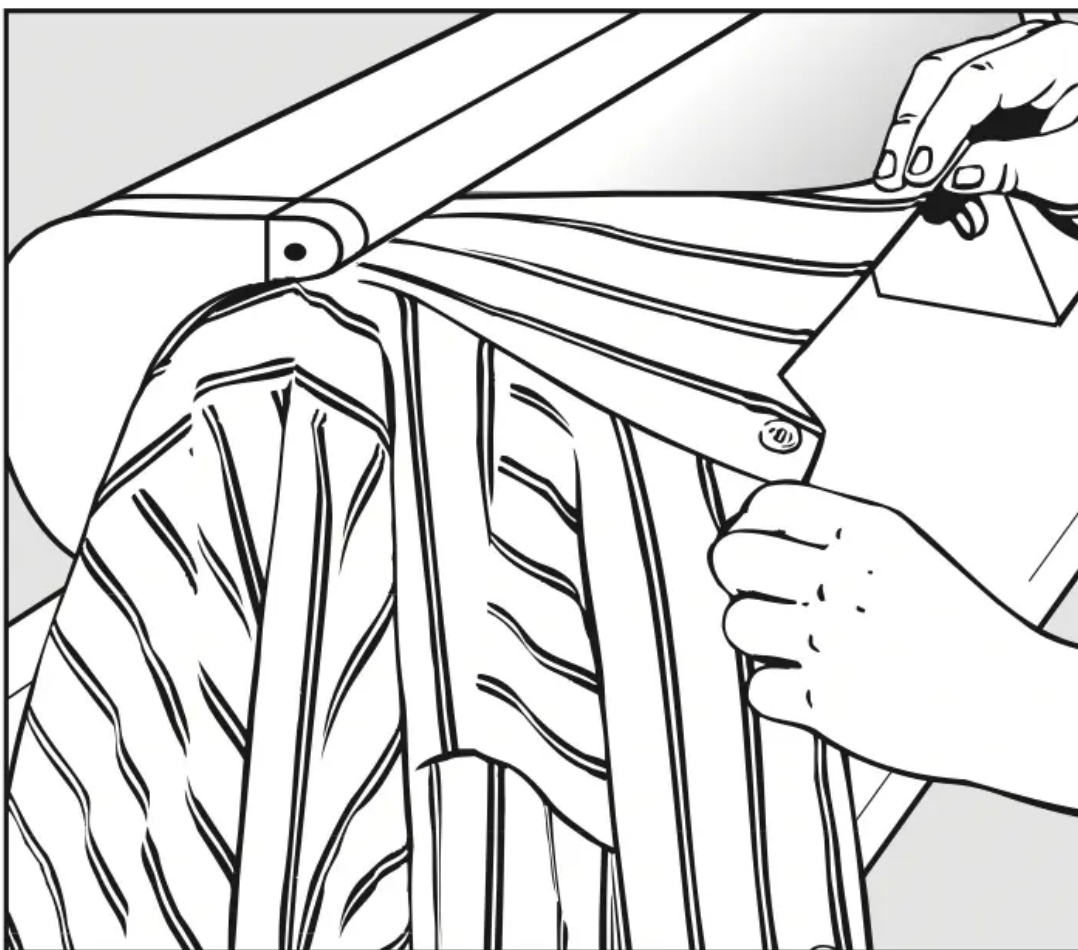

Then turn down the collar and press lightly, holding taut.

3. Front sides

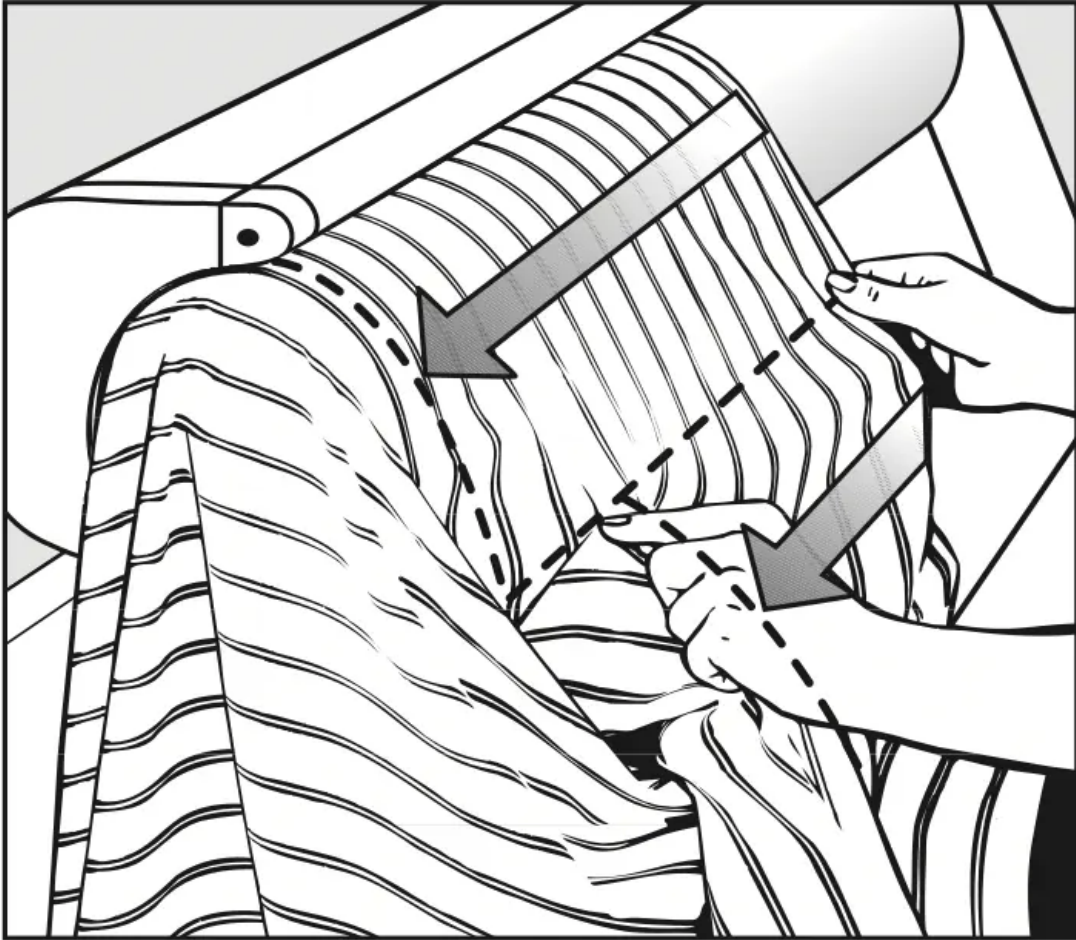

Lay the button hole front on the left hand end of the roller with the side seam along the edge of the roller.

Iron from the button hem up to the armhole.

Now move the shirt out and iron past the armhole to the side seam.

Iron the button side inside out so the buttons are pressed into the cushioned surface of the roller.

4. Back

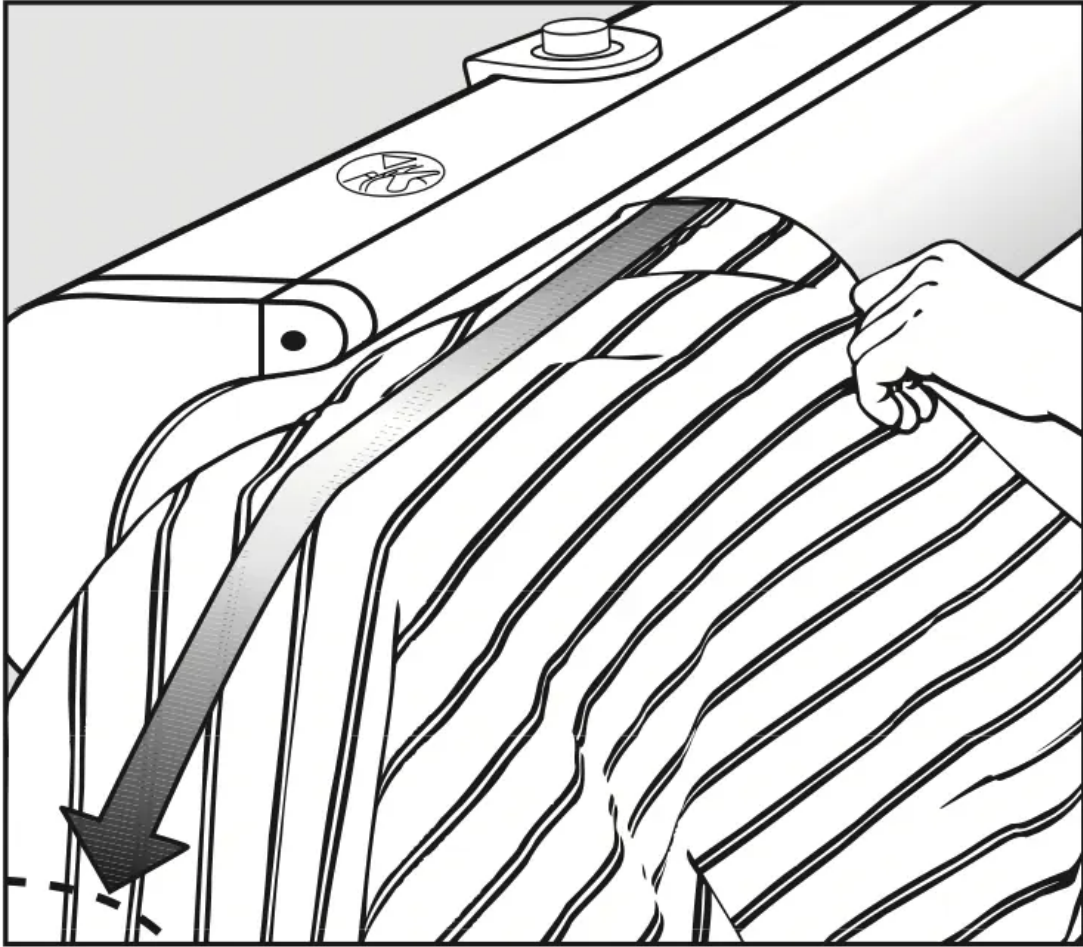

Start at the side seam. Pull the shirt over the roller as far as the arm hole. Smooth it out. Starting from the side seam iron past the armhole, then pull the shirt further onto the roller and iron the full back length to the second arm hole.

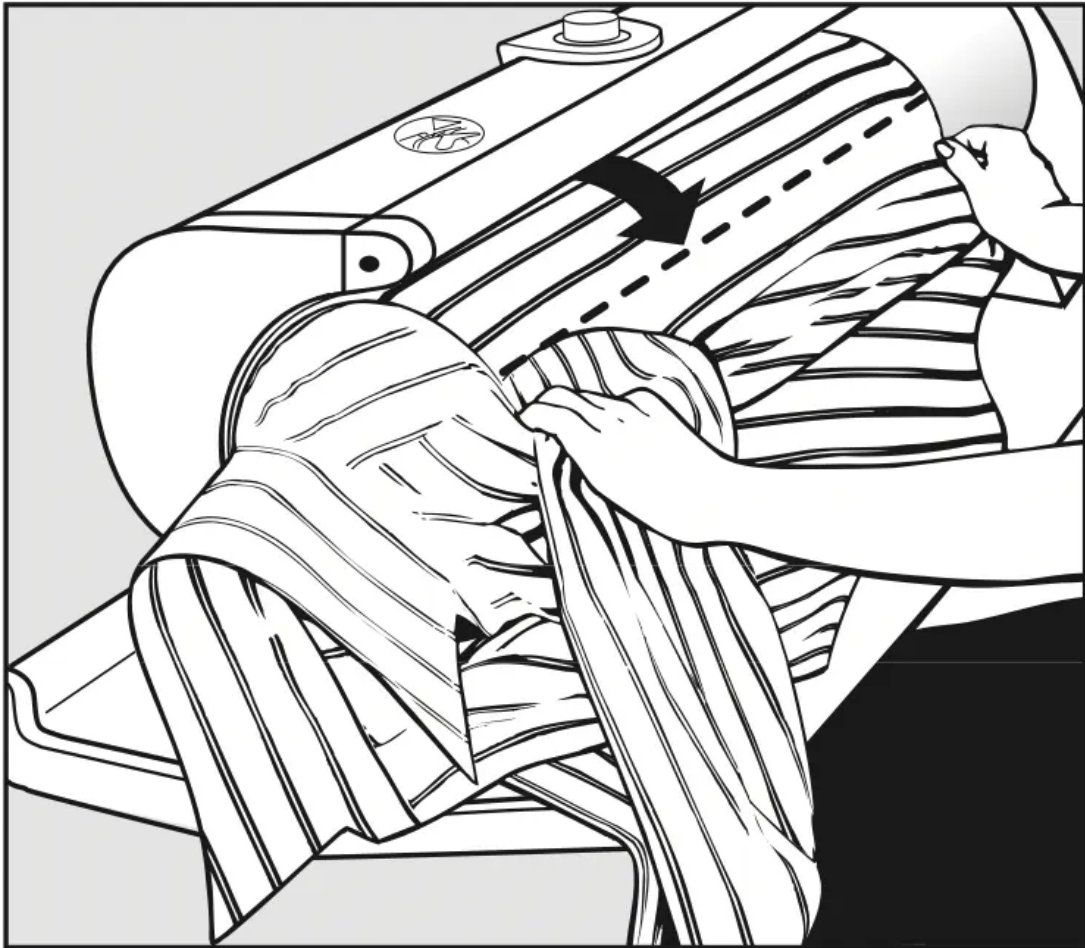

Pull the shirt further down the roller and iron past the arm hole.

5. Cuffs and sleeves

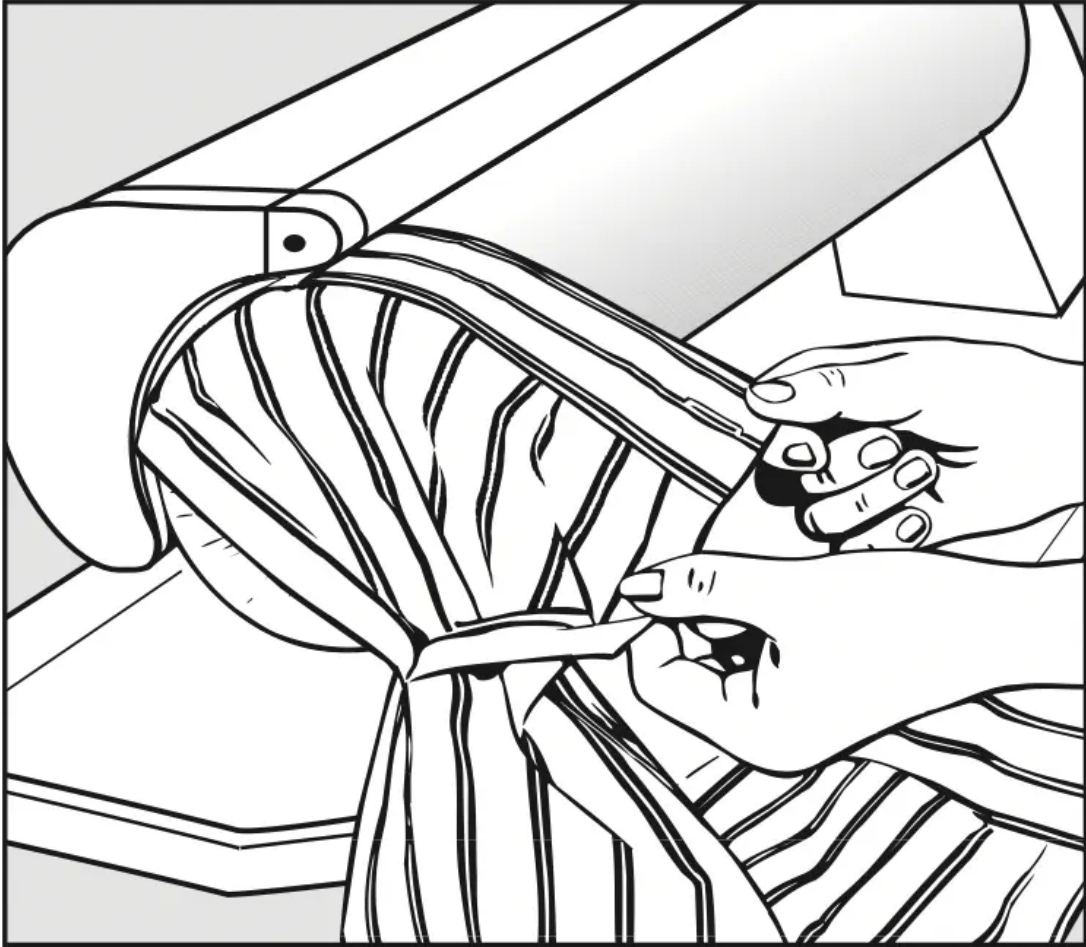

First iron both sides of the cuff on the left edge of the roller. Fold double-cuffs with one button hole placed over the other one and press lightly. Smooth out the sleeve and place it on the edge of the roller.

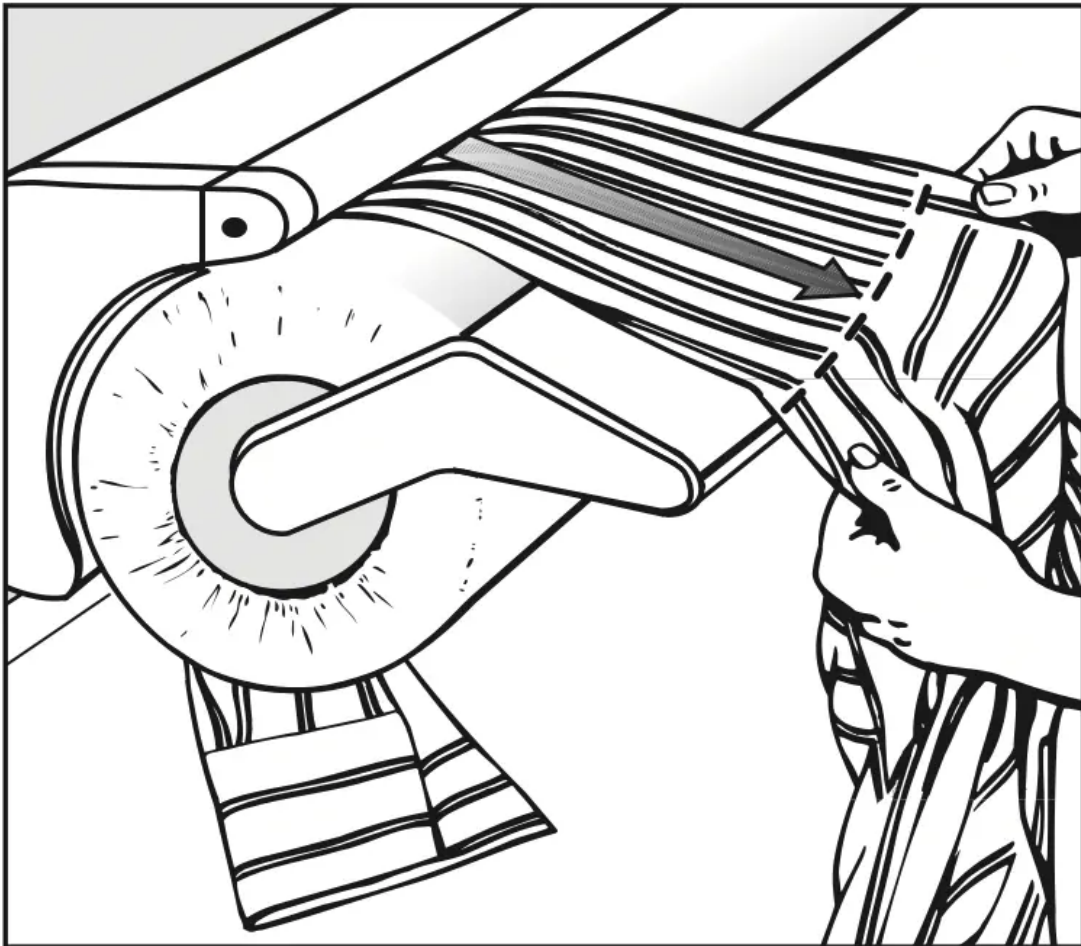

Iron the arm from the edge of the cuff to the underarm. Shift diagonally to iron the full width of the arm hole.

Pants

Ironing pants and jeans

- Iron the upper part from waistband to inseam of pants and jeans in sections. Set on a slow speed.
- Iron the legs from hem to inseam one leg after another.

Pressing woolen and dress pants

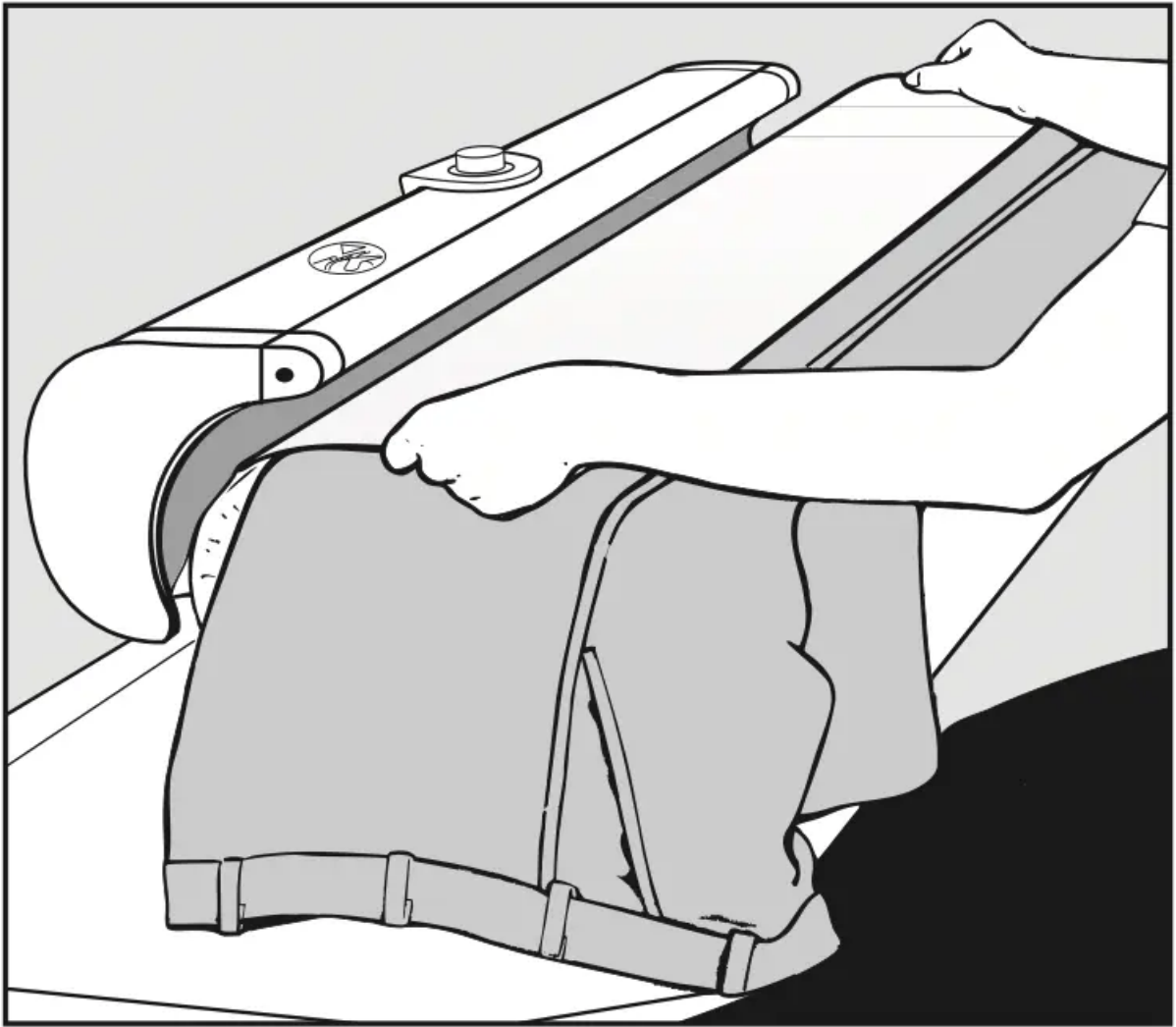

- Lay the pant legs separately on the roller. Let the upper part hang down over the left hand edge of the roller.
- Cover with a damp cloth. Then turn the roller by hand until the part of the pants to be pressed is covered by the heater plate.
- Press each leg from both sides starting from the crease.

Skirts

These are best ironed without the feed board.

- Pull the skirt over the roller from the hem to the waistband.
- Lay a damp cloth over it.
- Iron each section of the skirt in turn.

Cleaning and Care

Turn the iron off and unplug it from the outlet before performing any maintenance work.

Cleaning the heater plate

- Check that the temperature selector is set **I**.
- Allow the heater plate to cool before cleaning.
- Pull the emergency release lever up to make sure easier cleaning.
- Clean lime or starch deposits from the heater plate using a non abrasive household cleaner. Avoid spraying the heater plate.

Do not use abrasive cleaners.

Cleaning the casing

- Depending on soiling, the casing can be wiped down with a dry or damp cloth.

Do not use abrasive cleaners.

Washing or replacing the iron cover

It is normal for the ironing cover on the roller to become slightly brown with use.

- Wash the cover with a hot temperature program (140°F [60°C]).

If the cover looks worn and used, it can be easily replaced.

Ironing covers are available at your Miele dealer or Miele.

Warning: The ironing cover should only be changed when the appliance is cold.

- Remove the feed board.

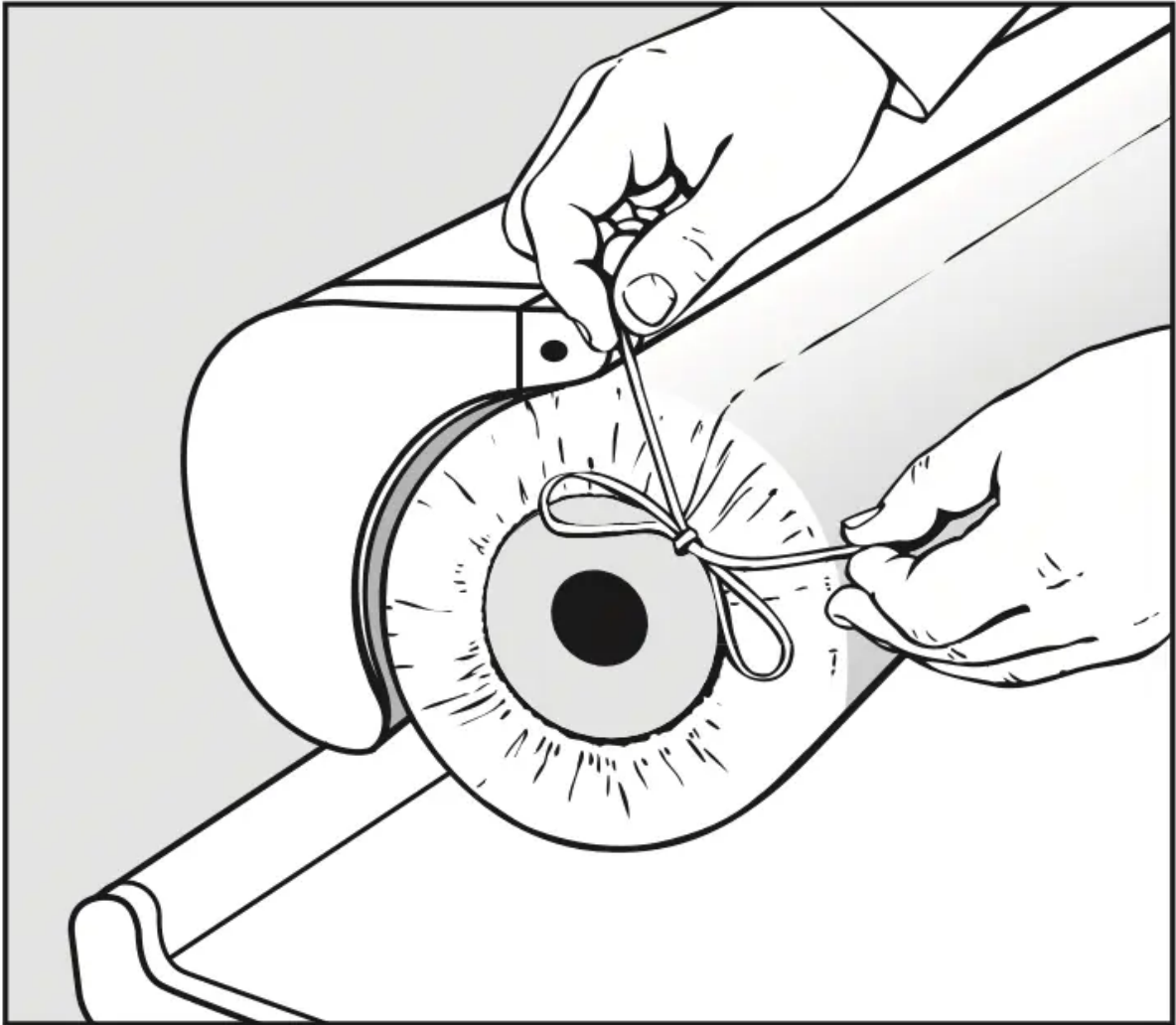

- Untie the old ironing cover cords at each end of the roller.

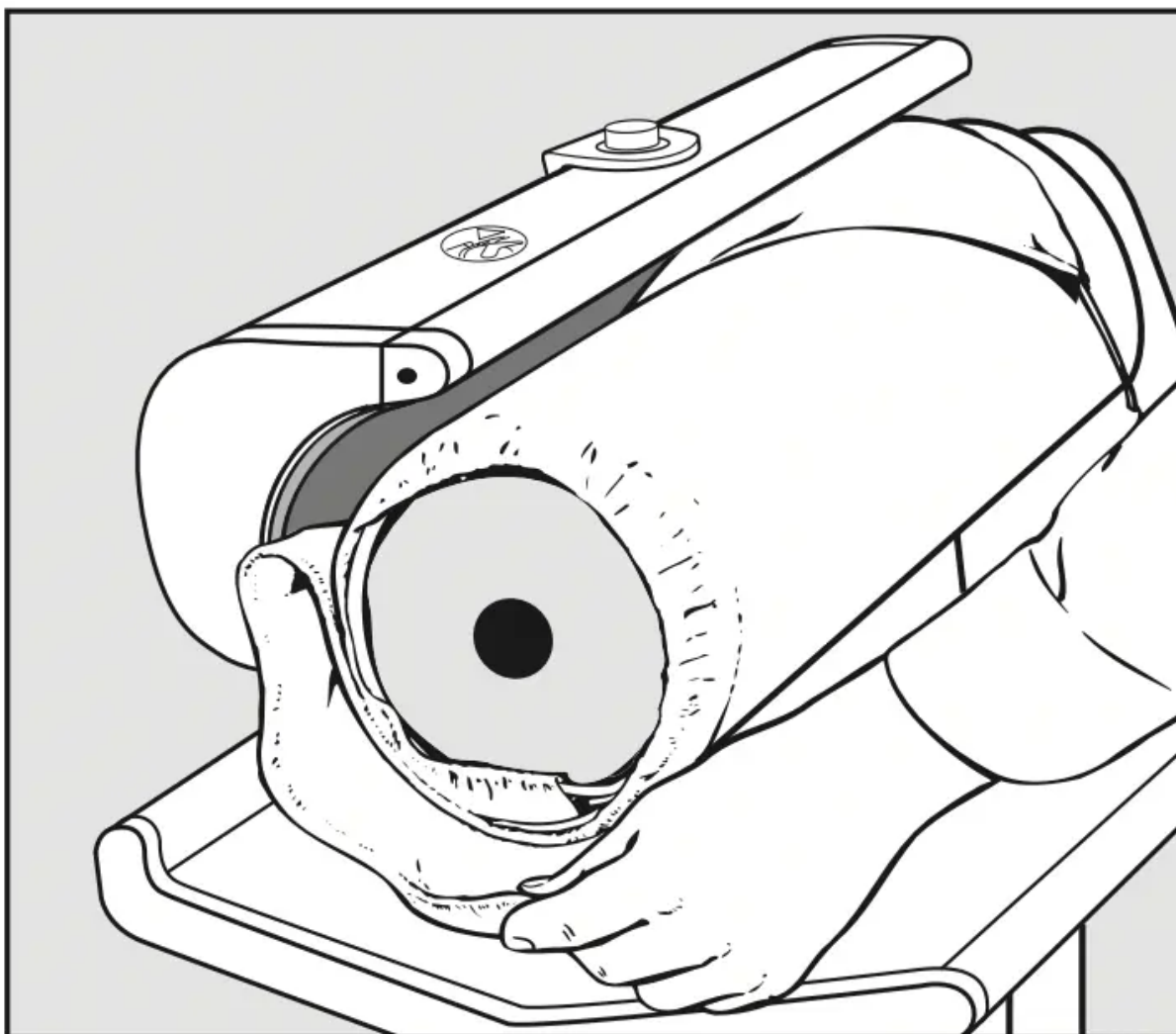

- Unwind the old ironing cover.

When the iron is turned on, the heater plate heats up immediately. The temperature selector must be turned to the  setting.

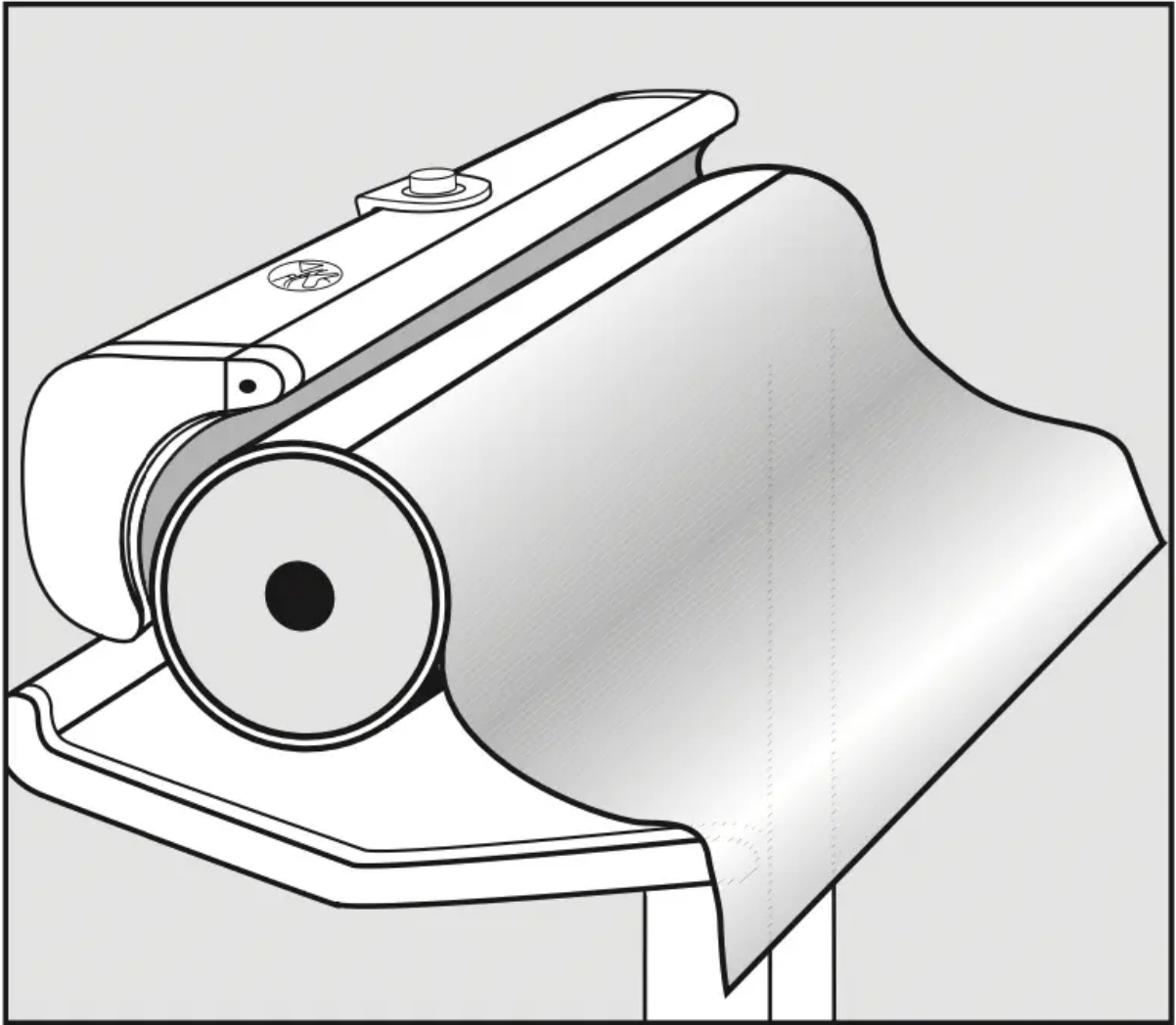

- Completely unwind the padding cover attached to the roller and let it hang down smoothly.

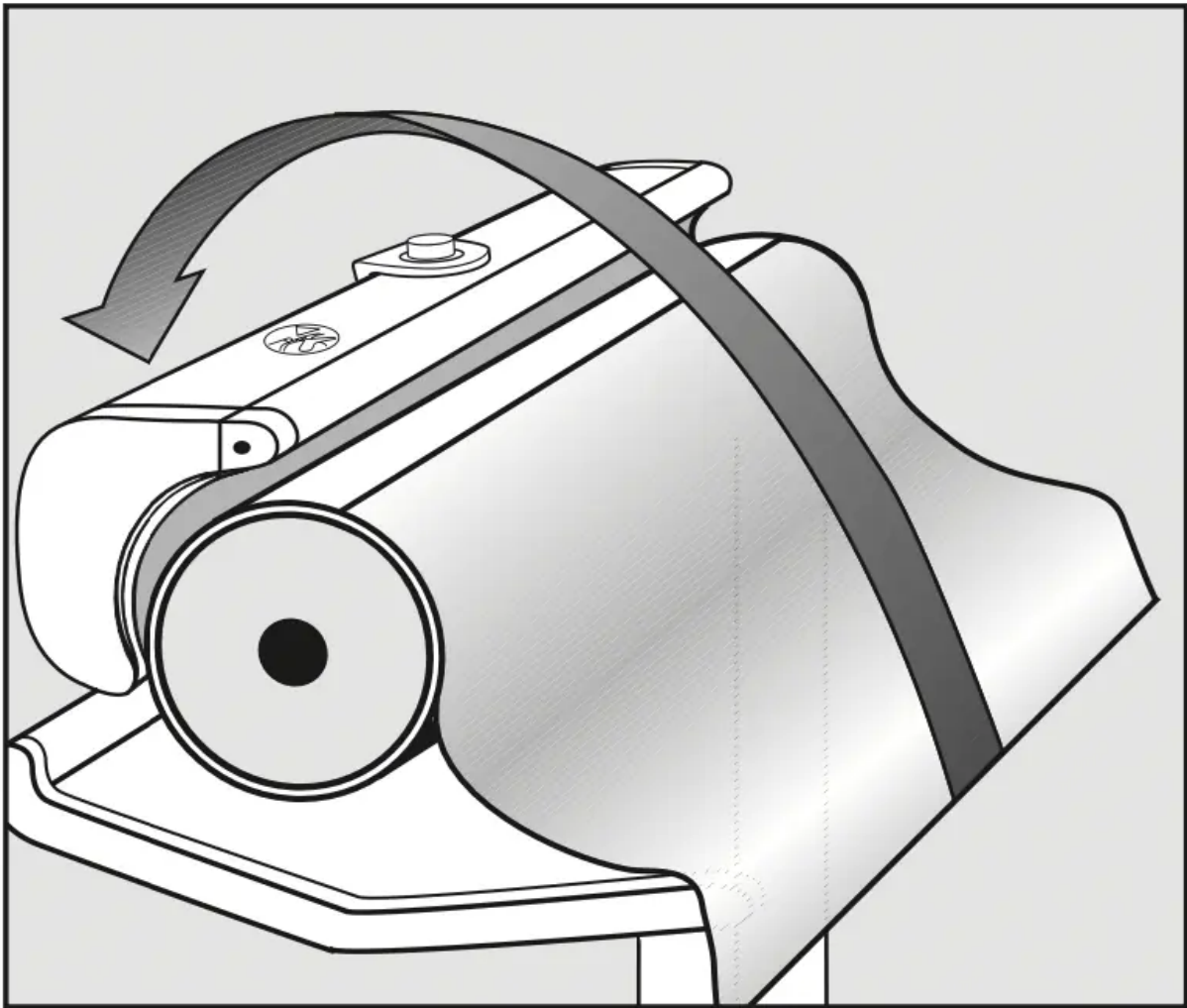

- Hold the corners of the padding cover, pull taut and keeping taut lay over the heater plate.

The slot which holds the ironing cover is now at the top.

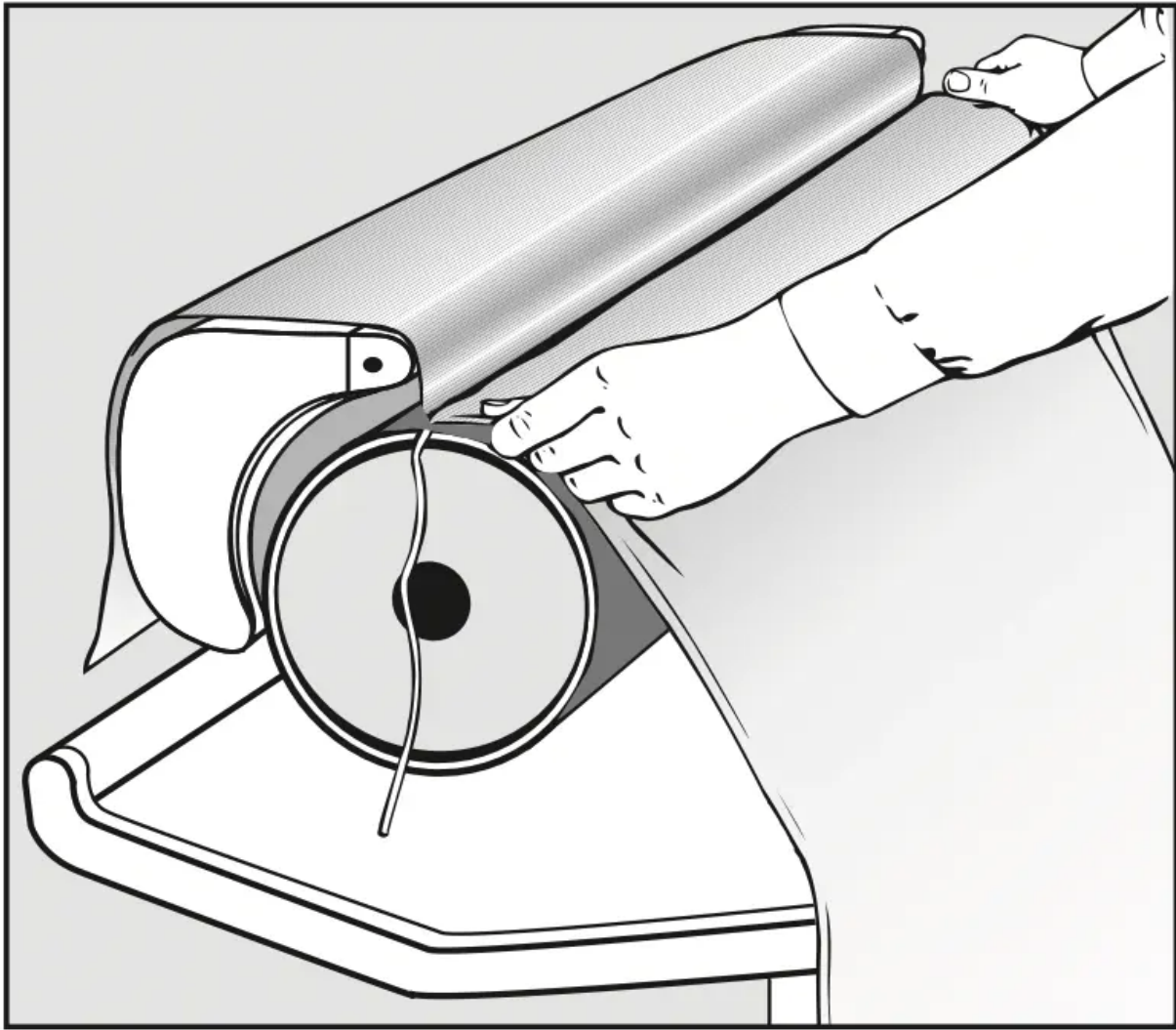

- Insert the long edge of the new ironing cover into the retaining slot with the side seams inside (upside down). Keep side ties hanging free and smooth out.

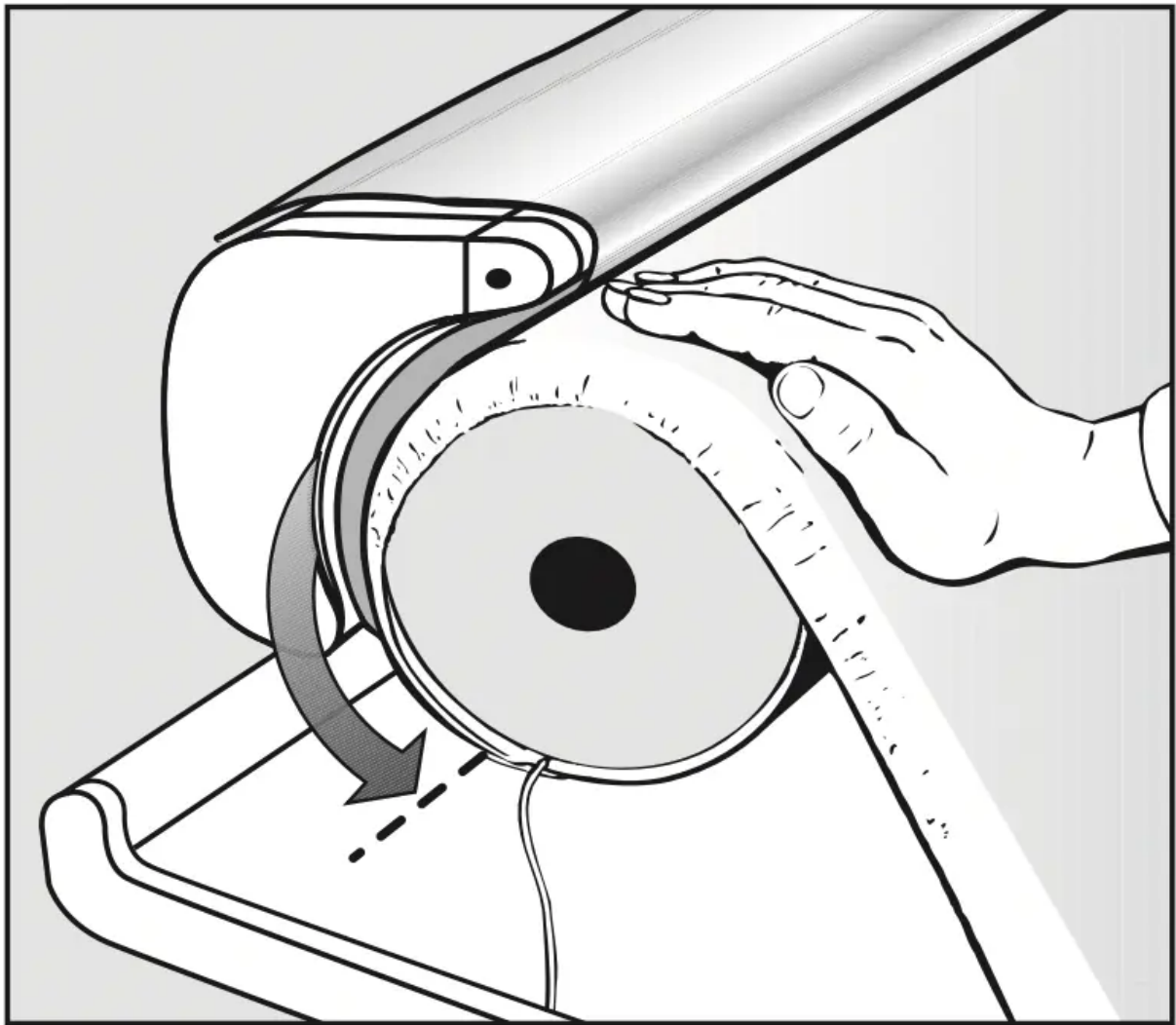

- Turn the roller by hand in the direction you iron (see arrow) until the retaining slot is at the bottom.
- Turn the rotary iron on.

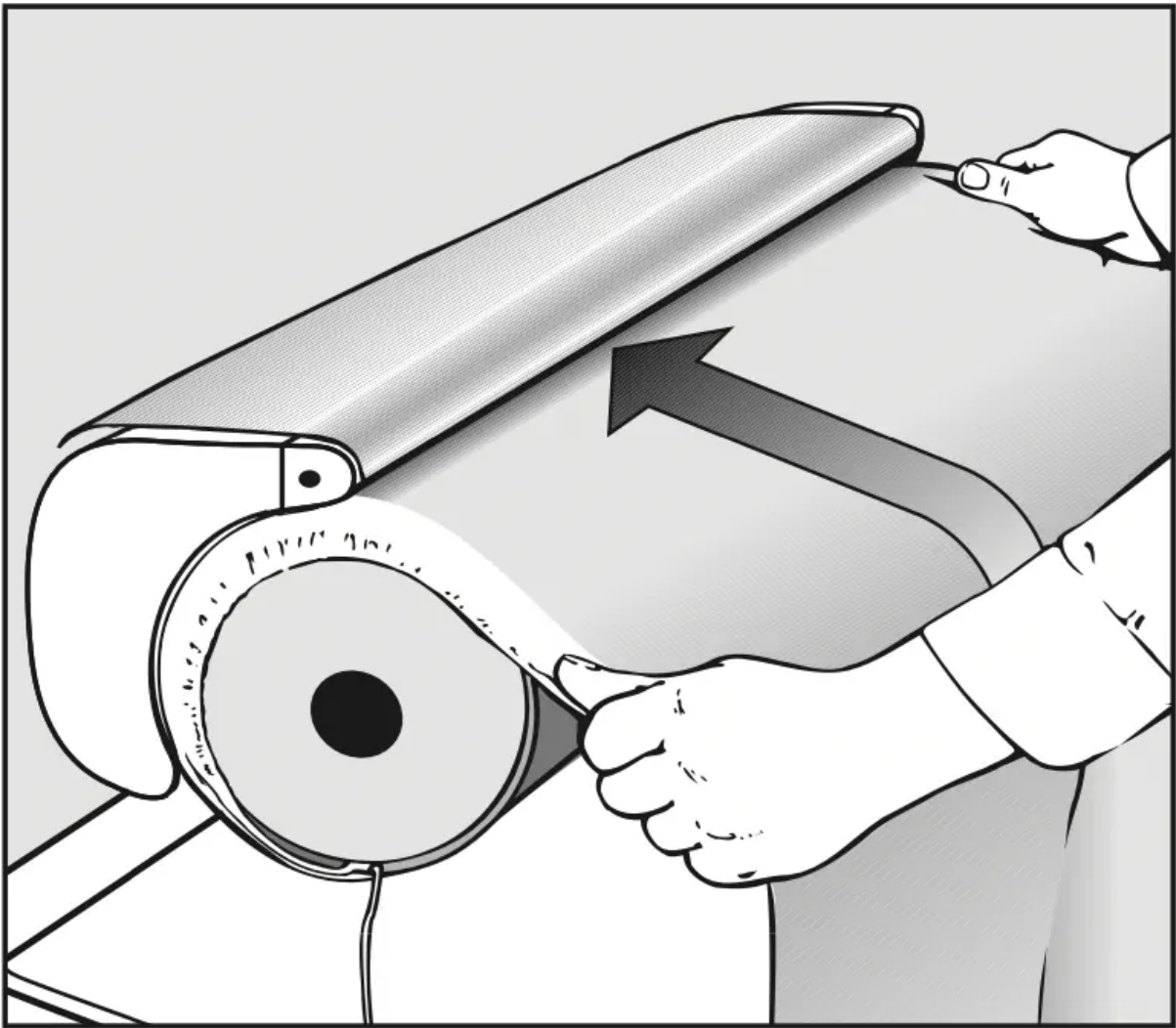

- Press the foot pedal and "iron" the new cloth around.

Do not let the cords get under the cloth as it turns.

After the roller has gone through three or four revolutions and the end of the ironing cover is under the heater plate:

- Turn the rotary iron off while keeping the foot pedal pressed down.

The ironing cover is held firmly in place with the heater plate which is still lowered.

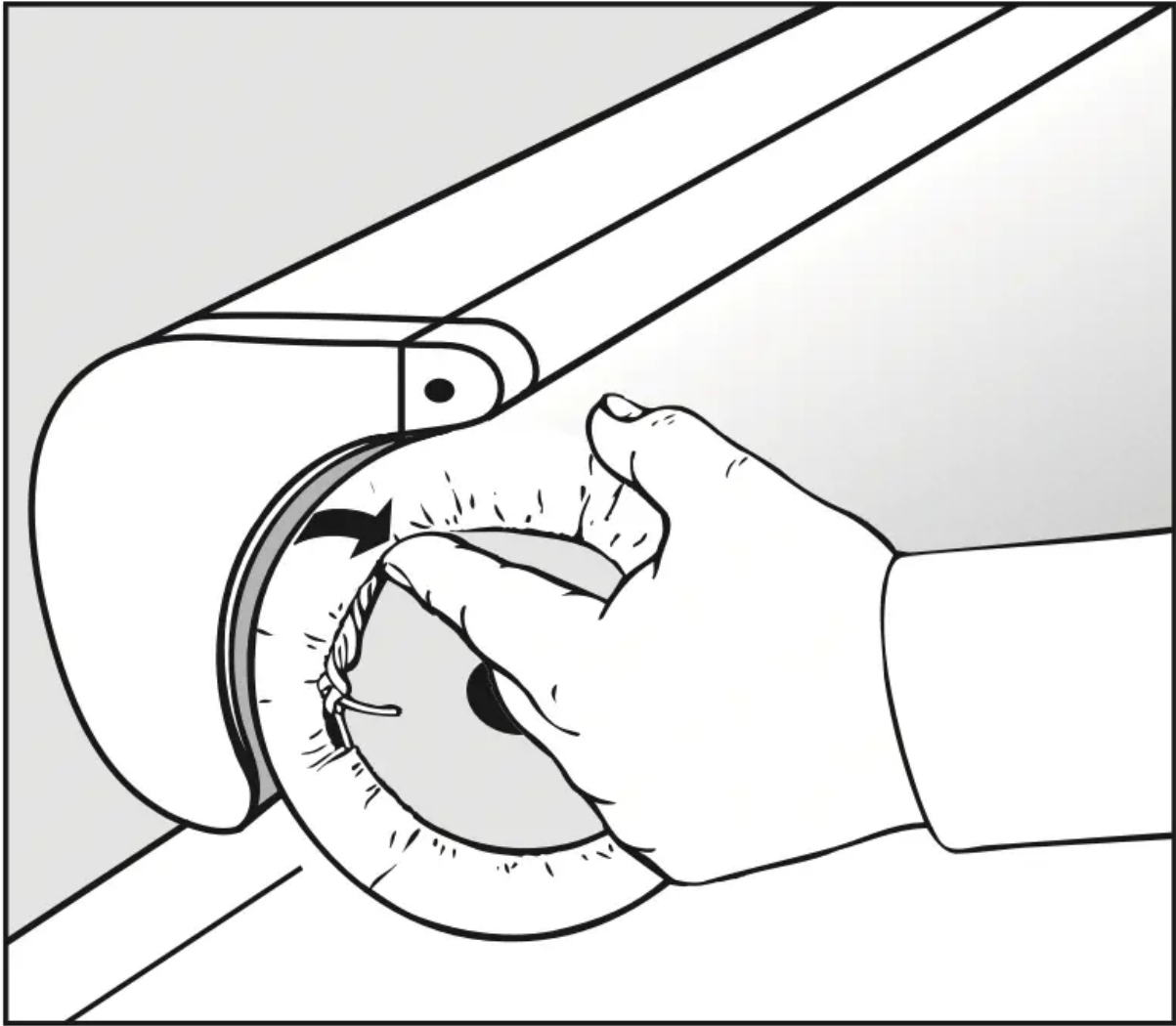

- Tighten the cords at the left and right hand sides of the roller, tie together and tuck in.
- Put the feed board back in place.
- Turn the rotary iron on - the heater plate will rise.

Troubleshooting

Repairs should only be carried out by an authorized technician in accordance with local and national safety regulations. Unauthorized repairs could cause injury or appliance damage.

The rotary iron does not turn on.	
Possible fault	Solution
The rotary iron has no power.	Plug the machine in and check if the circuit breaker has tripped.
The laundry is not properly or poorly pulled in.	
This tends to happen when ironing delicate items with a new machine.	Continue ironing, the issue is usually resolved after 5-10 minutes of ironing.
New iron cover	A new rotary iron cover should be washed at 140°F (60°C) for the laundry to be ideally pulled in.
Lime or starch deposits on the heater plate.	Clean with household cleaners or dishwasher detergent.
Creases/Folds occur	
The heater plate is soiled (lime deposits).	Clean the heater plate with household cleaners or dishwasher detergent.
The rotary iron cover is heavily soiled.	
Deposits	Wash the iron cover with household detergent at 140°F (60°C) or replace with a new one. See "Washing or replacing the ironing cover".
The heater plate does not press on the roller.	
The emergency release was activated.	Press the emergency release down (see "Power failure").

Warning

This content is compiled from multiple sources and is provided for reference purposes only. It may not be complete or fully applicable to all situations. If you are unable to resolve your issue, please contact the product manufacturer or an authorized service provider for official support.

Document generated by [ManualsFile](#)

