

# FEATURE GUIDE

## WARNING: Food Poisoning Hazard

- Do not let food sit in oven more than one hour before or after cooking.
- Doing so can result in food poisoning or sickness.

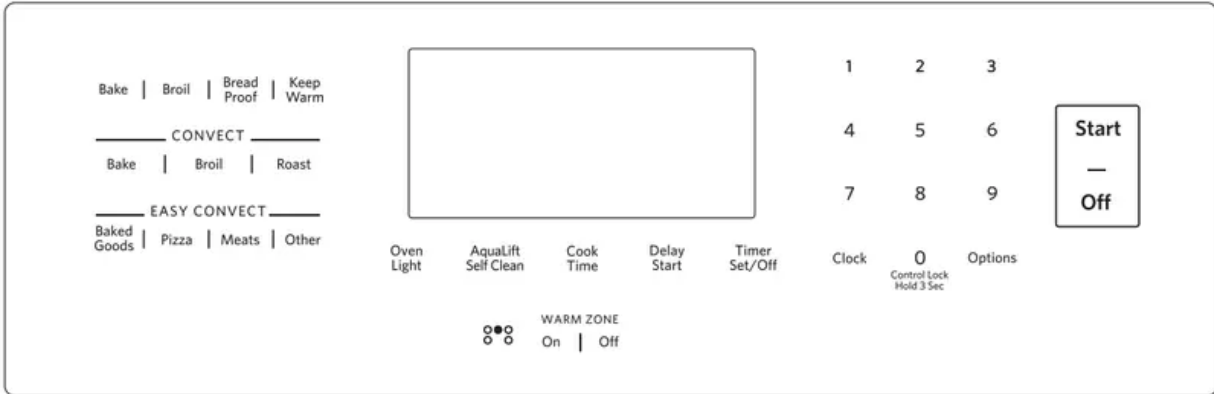

KEYPAD	FEATURE	INSTRUCTIONS
CLOCK	Clock	<p>This clock can use a 12- or 24-hour cycle.</p> <ol style="list-style-type: none"> <li>1. Press CLOCK.</li> <li>2. Press “3” for AM or “6” for PM.</li> <li>3. Press the number keypads to set the time of day.</li> <li>4. Press CLOCK or START.</li> </ol>
OVEN LIGHT	Oven cavity light	<p>While the oven door is closed, press OVEN LIGHT to turn the light on and off. The oven light will come on when the oven door is opened.</p>
TIMER SET/OFF	Oven timer	<p>The Timer can be set in hours or minutes up to 9 hours and 59 minutes.</p> <ol style="list-style-type: none"> <li>1. Press TIMER SET/OFF.</li> <li>2. Press the number keypads to set the length of time in hr-min-min. Leading zeros do not have to be entered. For example, for 2 minutes, enter “2.”</li> <li>3. Press TIMER SET/OFF to begin the countdown. If enabled, end-of-cycle tones will sound at end of countdown.</li> <li>4. Press TIMER SET/OFF to cancel the Timer and return to the time of day. Do not press the Off keypad because the oven will turn off.</li> </ol>
START	Cooking start	<p>The Start keypad begins any oven function. If Start is not pressed within 2 minutes after pressing a keypad, the function is canceled and the time of day is displayed.</p>
OFF	Range function	<p>The Off keypad stops any oven function except the Clock, Timer, Control Lock, and Warm Zone.</p>
BAKE		<ol style="list-style-type: none"> <li>1. Press BAKE.</li> </ol>



KEYPAD	FEATURE	INSTRUCTIONS
	Baking and roasting	<p>2. Press the number keypads to set the desired temperature. If the temperature entered is not in the range of the temperatures allowed, the minimum or maximum allowed temperature will be displayed. Enter a temperature in the allowable range.</p> <p>3. Press START.</p> <p>4. To change the temperature, repeat Step 2. Press START for the change to take effect.</p> <p>5. Press OFF when finished.</p>
BROIL	Broiling	<p>1. Press BROIL.</p> <p>2. Select the broiling temperature by pressing “1” - high (500°F [261°C]), “2” - medium (450°F [234°C]) or “3” - low (400°F [204°C]).</p> <p>3. Press START, and then allow the oven to preheat for 5 minutes.</p> <p>4. Position the cookware in the oven, and then leave the door open 6" (15 cm) at the broil stop position.</p> <p>5. Press OFF when finished.</p>
CONVECT BAKE	Convection cooking	<p>1. Press CONVECT BAKE.</p> <p>2. Press the number keypads to set the desired temperature. If the temperature entered is not in the range of the temperatures allowed, the minimum or maximum allowed temperature will be displayed. Enter a temperature in the allowable range.</p> <p>3. Press START.</p>

KEYPAD	FEATURE	INSTRUCTIONS
		<p>4. To change the temperature, repeat Step 2. Press START for the change to take effect.</p> <p>5. Press OFF when finished.</p>
CONVECT ROAST	Convection cooking	<p>1. Press CONVECT ROAST.</p> <p>2. Press the number keypads to set the desired temperature. If the temperature entered is not in the range of the temperatures allowed, the minimum or maximum allowed temperature will be displayed. Enter a temperature in the allowable range.</p> <p>3. Press START.</p> <p>4. To change the temperature, repeat Step 2. Press START for the change to take effect.</p> <p>5. Press OFF when finished.</p>
CONVECT BROIL	Convection cooking	<p>1. Press CONVECT BROIL.</p> <p>2. Press the number keypads to set the desired temperature. If the temperature entered is not in the range of the temperatures allowed, the minimum or maximum allowed temperature will be displayed. Enter a temperature in the allowable range.</p> <p>3. Press START and leave the door closed.</p> <p>4. To change the temperature, repeat Step 2. Press START for the change to take effect.</p> <p>5. Press OFF when finished.</p>
EASYCONVECT™ CONVERSION	Recipe conversion for	<p><b>NOTE:</b> For best results, preheat your oven to the required temperature prior to using EasyConvect™ Conversion. After</p>

KEYPAD	FEATURE	INSTRUCTIONS
	convection cooking	<p>preheating is complete, press OFF before using EasyConvect™ Conversion.</p> <ol style="list-style-type: none"> <li>1. Press the appropriate EasyConvect™ keypad (MEATS, PIZZA, BAKED GOODS or OTHER).</li> <li>2. Press START.</li> <li>3. Press the number keypads to enter the standard cook temperature, and then press START.</li> <li>4. Enter the standard cook time, and then press START.</li> <li>5. Place food in the oven at the appropriate time.</li> </ol> <p>Check food for doneness before the stop time is reached. If food will not be done when stop time is reached, add more cooking time before time elapses. At the end of the stop time, the oven will automatically turn off.</p> <ol style="list-style-type: none"> <li>6. Press OFF when finished.</li> </ol>
BREAD PROOF	Proofing bread	<ol style="list-style-type: none"> <li>1. Press BREAD PROOF until the desired proof is displayed (“Standard Proof” or “Rapid Proof”).</li> </ol> <p><b>NOTE:</b> “Rapid” operates at a slightly higher temperature for second rise of formed dough.</p> <ol style="list-style-type: none"> <li>2. Press START. Let the dough rise until nearly doubled in size. Proofing time may vary depending on dough type and quantity.</li> <li>3. Press OFF when finished proofing.</li> </ol>
KEEP WARM	Hold warm	<p>Food must be at serving temperature before placing it in the warmed oven.</p> <ol style="list-style-type: none"> <li>1. Press KEEP WARM.</li> </ol>

KEYPAD	FEATURE	INSTRUCTIONS
		<p>2. Press the number keypads to set the desired temperature. If the temperature entered is not in the range of the temperatures allowed, the minimum or maximum allowed temperature will be displayed. Enter a temperature in the allowable range.</p> <p>3. Press START.</p> <p>4. Press OFF when finished.</p>
DELAY START	Delayed start	The Delay Start keypad is used to enter the starting time for an oven function with a delayed start. Delay Start should not be used for foods such as breads and cakes because they may not bake properly
COOK TIME	Timed cooking	Cook Time allows the oven to be set to turn on at a certain time of day, cook for a set length of time, and/or shut off automatically
WARM ZONE ON/ OFF	Warming zone	Press WARM ZONE ON to select the warming element on the cooktop, and then press START. Press WARM ZONE OFF to turn off the warming element.
AQUALIFT SELF CLEAN	AquaLift® selfclean cycle	See the “Clean Cycle” section.
CONTROL LOCK hold 3 sec.	Oven control lockout	<p>No keypads will function with the controls locked.</p> <p>1. Check that the oven and the Timer are off.</p> <p>2. Press and hold the “0” keypad for 3 seconds.</p> <p>3. If enabled, a tone will sound, and “CONTROL LOCKED” will be displayed.</p> <p>4. Repeat to unlock</p>

KEYPAD	FEATURE	INSTRUCTIONS
OPTIONS	Oven use functions	Enables you to personalize the audible tones and oven operation to suit your needs.

## COOKTOP USE

### WARNING: Fire Hazard

- Turn off all controls when done cooking.
- Failure to do so can result in death or fire.

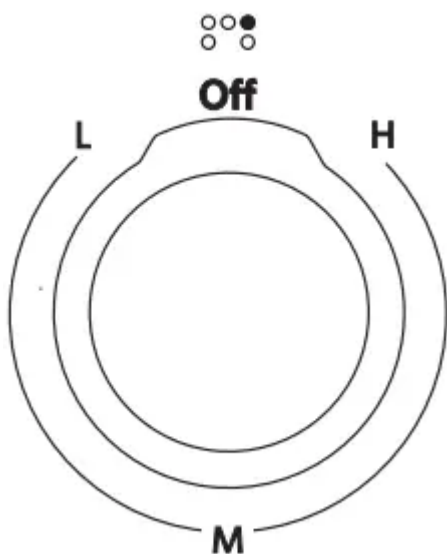

The control knobs can be set to anywhere between “H” and “L.” Push in and turn to setting.

**REMEMBER:** When range is in use, the entire cooktop area may become hot.

### Ceramic Glass

The surface cooking area will glow red when an element is on. Some parts of the surface cooking area may not glow red when an element is on. This is normal operation. It will also randomly cycle off and back on again, even while on High, to keep the cooktop from extreme temperatures.

It is normal for the surface of ceramic glass to appear to change color when surface cooking areas are hot. As the glass cools, it will return to its original color.

Clean the cooktop after each use to help avoid scratches, pitting, abrasions and to condition the glass surface. Ceramic glass cooktop cleaner and a cooktop scraper are also recommended for stubborn soils. Do not use abrasive cleaners, cleaning pads or harsh chemicals for cleaning. The Cooktop Care Kit Part Number 31605 contains all of the items needed to clean and condition your ceramic glass cooktop.

**IMPORTANT:** To avoid permanent damage to the cooktop surface and to make soils easier to remove, clean the cooktop after each use to remove all soils.

- For cooktops with two dual elements in the front positions, the fastest boiling performance for pots 10" (25.4 cm) and larger will be on the larger dual element with both elements on "Dual Hi." For best low heat performance on pans 10" (25.4 cm) and larger, use the smaller dual element set at "Single Lo."
- For best melting performance with small pans, use the EvenHeat™ element.
- Use flat-bottomed cookware for best heat conduction and energy efficiency. Cookware with rounded, warped, ribbed or dented bottoms could cause uneven heating and poor cooking results.
- Determine flatness by placing the straight edge of a ruler across the bottom of the cookware. While you rotate the ruler, no space or light should be visible between it and the cookware.
- Cookware designed with slightly indented bottoms or small expansion channels can be used.
- Make sure the bottoms of pots and pans are clean and dry before using them. Residue and water can leave deposits when heated.
- Avoid storing jars or cans above the cooktop. Dropping a heavy or hard object onto the cooktop could crack the cooktop.
- To avoid damage to the cooktop, do not leave a hot lid on the cooktop. As the cooktop cools, air can become trapped between the lid and the cooktop, and the ceramic glass could break when the lid is removed.
- For foods containing sugar in any form, clean up all spills and soils as soon as possible. Allow the cooktop to cool down slightly. Then, while wearing oven mitts, remove the spills using a scraper while the surface is still warm. If sugary spills are allowed to cool down, they can adhere to the cooktop and can cause pitting and permanent marks.
- To avoid scratches, do not slide cookware or bakeware across the cooktop. Aluminum or copper bottoms and rough finishes on cookware or bakeware could leave scratches or marks on the cooktop.
- Do not cook popcorn in prepackaged aluminum containers on the cooktop. They could leave aluminum marks that cannot be removed completely.
- To avoid damage to the cooktop, do not allow objects that could melt, such as plastic or aluminum foil, to touch any part of the entire cooktop.
- To avoid damage to the cooktop, do not use the cooktop as a cutting board.
- To avoid damage to the cooktop, do not cook foods directly on the cooktop.

## Cooktop On Indicator Light

The Cooktop On Indicator Light is located on the console panel. When any control knob on the console panel is turned on, the Cooktop On Indicator Light will glow.

## Hot Surface Indicator Light

On ceramic glass models, the Hot Surface Indicator Light is located on the console panel. The Hot Surface Indicator Light will glow as long as any surface cooking area is too hot to touch, even after the surface cooking area is turned off.

## Dual-Size Cooking Element

The Dual-Size Cooking Element offers flexibility depending on the size of the cookware. Single size can be used in the same way as a regular element. The dual size combines both the single and outer element and is recommended for larger size cookware.

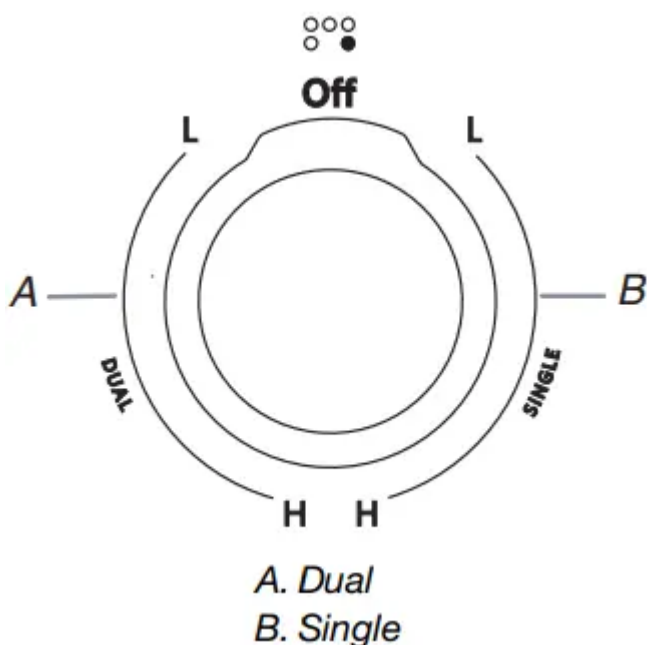

## Even-Heat™ Element

The Even-Heat™ Element offers flexibility due to a wide range of settings between High and Melt. The High heat option can be used to boil small amounts of liquid quickly. To reduce the power setting, turn the knob clockwise. The Melt setting is designed for delicate foods that require low heat, such as when melting chocolate or holding sauces. Use cookware appropriate in size for the Even-Heat™ Element.

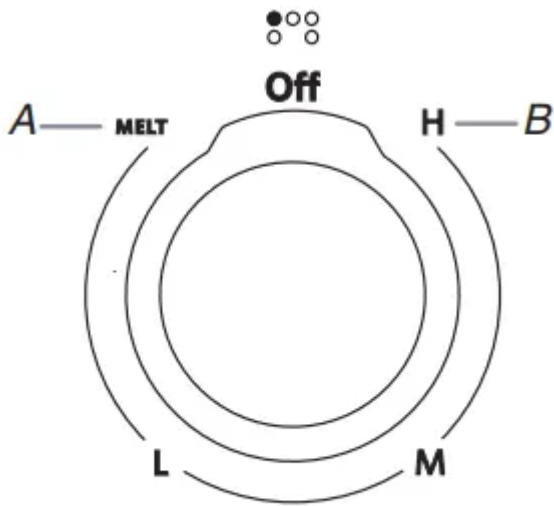

*A. Melt option*  
*B. High heat option*

## Warm Zone Element

**WARNING:** Food Poisoning Hazard

- Do not let food sit for more than one hour before or after cooking.
- Doing so can result in food poisoning or sickness.

Use the Cooktop Warm Zone element to keep cooked foods warm. One hour is the recommended maximum time to maintain food quality.

Do not use it to heat cold foods.

The Warm Zone element can be used alone or when any of the other surface cooking areas are being used.

The Warm Zone element area will not glow red when cycling on. However, the Element On indicator light will glow while the Cooktop Warm Zone element is in use.

Use only cookware recommended for oven and cooktop use.

Cover all foods with a lid or aluminum foil. When warming baked goods, allow a small opening in the cover for moisture to escape.

To avoid damage to the cooktop, do not use plastic wrap to cover food because the plastic wrap may melt.

Use pot holders or oven mitts to remove food.

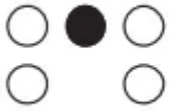

# WARM ZONE

## On



## Off

### To Use:

1. To turn on, press WARM ZONE ON and then START.
2. To turn off, press WARM ZONE OFF.

### Cookware

**IMPORTANT:** Do not leave empty cookware on a hot surface cooking area, element or surface burner.

Ideal cookware should have a flat bottom, straight sides and a wellfitting lid, and the material should be of medium-to-heavy thickness.

Rough finishes may scratch the cooktop. Aluminum and copper may be used as a core or base in cookware. However, when used as a base, they can leave permanent marks on the surfaces.

Cookware material is a factor in how quickly and evenly heat is transferred, which affects cooking results. A nonstick finish has the same characteristics as its base material. For example, aluminum cookware with a nonstick finish will take on the properties of aluminum.

Cookware with nonstick surfaces should not be used under the broiler.

Check for flatness by placing the straight edge of a ruler across the bottom of the cookware. While you rotate the ruler, no space or light should be visible between it and the cookware.

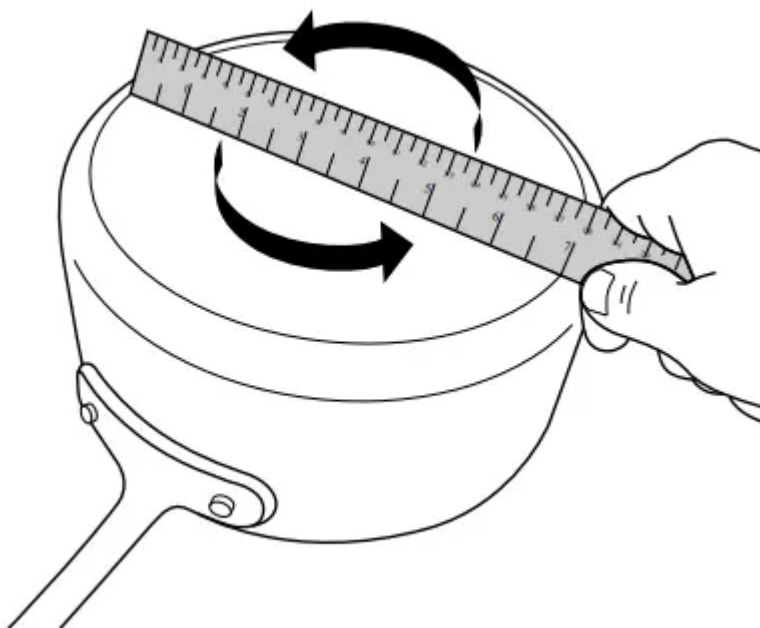

Use the following chart as a guide for cookware material characteristics.

Cookware	Characteristics
Aluminum	<p>Heats quickly and evenly.</p> <p>Suitable for all types of cooking.</p> <p>Medium or heavy thickness is best for most cooking tasks.</p> <p>May leave aluminum residues, which may be diminished if cleaned immediately after cooking.</p>
Cast iron	<p>Heats slowly and evenly.</p> <p>Good for browning and frying.</p> <p>Maintains heat for slow cooking.</p> <p>Rough edges or burrs may scratch the cooktop.</p>
Ceramic or Ceramic glass	<p>Follow manufacturer's instructions.</p> <p>Heats slowly, but unevenly.</p> <p>Ideal results on low to medium heat settings.</p> <p>May scratch the cooktop.</p>
Copper	<p>Heats very quickly and evenly.</p> <p>May leave copper residues, which may be diminished if cleaned immediately after cooking.</p> <p>Can leave a permanent stain or bond to the cooktop if overheated.</p>
Earthenware	<p>Follow manufacturer's instructions.</p> <p>Use on low heat settings.</p> <p>May scratch the cooktop.</p>
Porcelain enamel-on steel or cast iron	<p>See stainless steel or cast iron.</p> <p>Porcelain enamel bakeware without the metal base may bond to the cooktop if overheated.</p>
Stainless steel	<p>Heats quickly, but unevenly.</p>



Cookware	Characteristics
	A core or base of aluminum or copper on stainless steel provides even heating.

Use flat-bottomed cookware for best cooking results and energy efficiency. The cookware should be about the same size as the cooking area outlined on the cooktop. Cookware should not extend more than ½" (1.3 cm) outside the area.

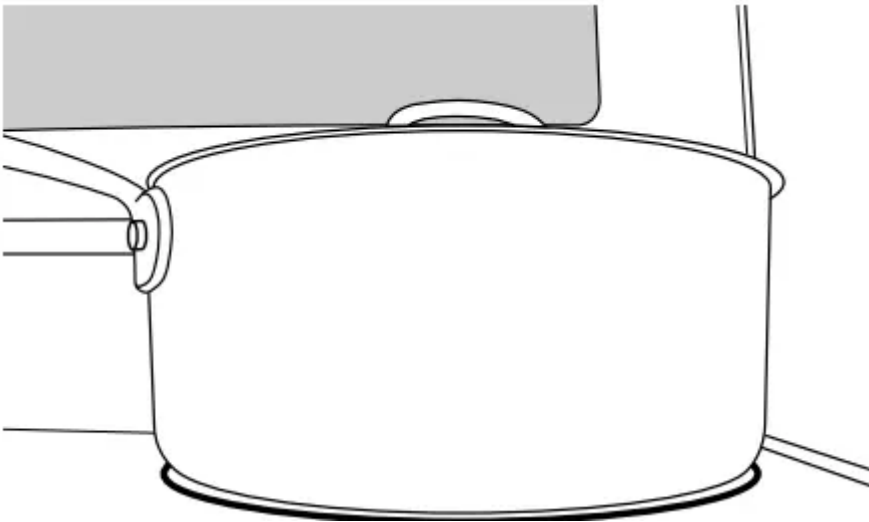

## Home Canning

Canning can be performed on a glass smooth top cooking surface or traditional coil element cooktop. When canning for long periods, alternate the use of surface cooking areas or elements between batches. This allows time for the most recently used areas to cool.

- Center the canner on the largest surface cooking area or element. On electric cooktops, canners should not extend more than ½" (1.3 cm) beyond the surface cooking area or element.
- Do not place canner on 2 surface cooking areas or elements at the same time.
- On ceramic glass models, use only flat-bottomed canners to avoid damage to the cooktop and elements.
- For more information, contact your local agricultural extension office, or refer to published home canning guides. Companies that manufacture home canning products can also offer assistance.

## OVEN USE

Odors and smoke are normal when the oven is used the first few times, or when it is heavily soiled.

**IMPORTANT:** The health of some birds is extremely sensitive to the fumes given off. Exposure to the fumes may result in death to certain birds. Always move birds to another closed and well-ventilated room.

## **Electronic Oven Controls**

### **Control Display**

The display will light up when first powered up or after a power loss. When oven is not in use, the time of day is displayed.

### **Tones**

Tones are audible signals, indicating the following:

#### **One Tone**

Valid pad press.

Oven is preheated (long tone).

Kitchen timer (long tone with a reminder tone every 60 seconds).

Function has been entered.

#### **Three Tones**

Invalid pad press.

#### **Four Tones**

End of cycle (with a reminder tone every 60 seconds).

Use the Options key to change the tone settings.

### **Options**

Many features of the oven control can be adjusted to meet your personal needs. These changes are made using the Options keypad.

Use the Options keypad to scroll through the features that can be changed. Each press of the Options keypad will advance the display to the next setting. After selecting the feature to be changed, the control will prompt you for the required input. Details of all of the feature changes are explained in the following sections. Press OFF to exit Options.

#### **Fahrenheit and Celsius**

The temperature is preset to Fahrenheit, but can be changed to Celsius.

1. Press OPTIONS until "TEMP UNIT" is displayed.
2. The current setting will be displayed.

3. Press the “1” keypad to adjust the setting.
4. Press OFF to save the setting and display the time of day.

### **Audible Tones Disable**

Turns off all tones, including the end of cycle tone and key press tones.

1. Press OPTIONS until “SOUND” is displayed.
2. The current setting will be displayed.
3. Press the “1” keypad to adjust the setting.
4. Press OFF to save the setting and display the time of day.

### **Sound Volume**

Sets the pitch of the tone to either high or low.

1. Press OPTIONS until “SOUND VOLUME” is displayed.
2. The current setting will be displayed.
3. Press the “1” keypad to adjust the setting.
4. Press OFF to save the setting and display the time of day.

### **End of Cycle Tone**

Activates or turns off the tones that sound at the end of a cycle.

1. Press OPTIONS until “END TONE” is displayed.
2. The current setting will be displayed.
3. Press the “1” keypad to adjust the setting.
4. Press OFF to save the setting and display the time of day.

### **Key Press Tones**

Activates or turns off the tones when a keypad is pressed.

1. Press OPTIONS until “KEYPRESS TONE” is displayed.
2. The current setting will be displayed.
3. Press the “1” keypad to adjust the setting.
4. Press OFF to save the setting and display the time of day.

## Reminder Tones Disable

Turns off the short repeating tone that sounds every 1 minute after the end of cycle tones.

1. Press OPTIONS until "REMINDER TONE" is displayed.
2. The current setting will be displayed.
3. Press the "1" keypad to adjust the setting.
4. Press OFF to save the setting and display the time of day.

## 12/24 Hour Clock

1. Press OPTIONS until "12/24 HOUR" is displayed.
2. The current setting will be displayed.
3. Press the "1" keypad to adjust the setting.
4. Press OFF to save the setting and display the time of day.

## Demo Mode

**IMPORTANT:** This feature is intended for use on the sales floor with 120 V power connection and permits the control features to be demonstrated without heating elements or burners turning on. If this feature is activated, the oven will not work.

1. Press OPTIONS until "DEMO MODE" is displayed.
2. The current setting will be displayed.
3. Press the "1" keypad to adjust the setting.
4. Press OFF to save the setting and display the time of day.

## 12-Hour Shutoff

The oven control is set to automatically shut off the oven 12 hours after the oven initiates a cook or clean function. This will not interfere with any timed or delay cook functions.

1. Press OPTIONS until "12 HR AUTO OFF" is displayed.
2. The current setting will be displayed.
3. Press the "1" keypad to adjust the setting.
4. Press OFF to save the setting and display the time of day.

## Languages - Scrolling Display Text

Language options are English, Spanish and French.

1. Press OPTIONS until "LANGUAGE" is displayed.

2. The current setting will be displayed.
3. Press the number keypads to adjust the setting.
4. Press OFF to save the setting and display the time of day.

## Energy Save

The Energy Save mode deactivates the display to reduce energy consumption.

1. Press OPTIONS until "ENERGY SAVE" is displayed.
2. The current setting will be displayed.
3. Press the "1" keypad to adjust the setting.
4. Press OFF to save the setting and display the time of day.

## Oven Temperature Offset Control

**IMPORTANT:** Do not use a thermometer to measure oven temperature. Elements will cycle on and off as needed to provide consistent temperature but may run slightly hot or cool at any point in time due to this cycling. Most thermometers are slow to react to temperature change and will not provide an accurate reading due to this cycling.

The oven provides accurate temperatures; however, it may cook faster or slower than your previous oven, so the temperature can be adjusted to personalize it for your cooking needs. It can be changed to Fahrenheit or Celsius.

To Adjust Oven Temperature:

1. Press OPTIONS until "TEMP CALIB" is displayed.
2. The current setting will be displayed. Press the "1" keypad to toggle between the oven and the warming drawer.
3. Press START to select the choice displayed in Step 2. Wait 10 seconds for the display to change, or press START, and then continue with Step 4.
4. Press the "3" keypad to increase the temperature in 5°F (3°C) increments, or press the "6" keypad to decrease the temperature in 5°F (3°C) increments. The range is from -30°F to +30°F (-18°C to +18°C).
5. Press OFF to save the setting and display the time of day.

## Keep Warm

**WARNING:** Food Poisoning Hazard

- Do not let food sit in oven more than one hour before or after cooking.
- Doing so can result in food poisoning or sickness.

**IMPORTANT:** Food must be at serving temperature before placing it in the warmed oven. Food may be held up to 1 hour; however, breads and casseroles may become too dry if left in the oven during the Keep Warm function. For best results, cover food.

The Keep Warm feature allows hot cooked foods to stay at serving temperature.

**To Use:**

1. Press KEEP WARM.
2. Press the number keypads to set the desired temperature. If the temperature entered is not in the range of the temperatures allowed, the minimum or maximum allowed temperature will be displayed. Enter a temperature in the allowable range.

**NOTE:** The temperature may be changed at any time by pressing the number keypads to enter the desired temperature and then START.

3. Press START.
4. Place food in the oven.
5. Press OFF when finished.
6. Remove food from the oven.

**To Cancel Keep Warm:**

Press OFF. Remove food from oven.

**Sabbath Mode**

The Sabbath Mode sets the oven to remain on in a bake setting until turned off.

When the Sabbath Mode is set, only the Bake cycle will operate. All other cooking and cleaning cycles are disabled. No tones will sound, and the displays will not indicate temperature changes.

When the oven door is opened or closed, the oven light will not turn on or off and the heating elements will not turn on or off immediately.

**NOTE:** Warm Zone is not available when Sabbath Mode is enabled.

**To Enable Sabbath Mode Capability (One Time Only):**

1. Press OPTIONS until "SABBATH" is displayed.
2. Press the "1" keypad. Sabbath Mode can be activated for baking.
3. Press START or OFF to save the setting and display the time of day.

**NOTE:** To disable the Sabbath Mode, repeat steps 1 through 3 to change the status from "SABBATH ON" to "SABBATH OFF."

**To Activate Sabbath Mode:**

1. Press BAKE.



2. Press the number keypads to set the desired temperature. If the temperature entered is not in the range of the temperatures allowed, the minimum or maximum allowed temperature will be displayed. Enter a temperature in the allowable range.
3. Press START. For timed cooking in Sabbath Mode, press COOK TIME, then the number keypad to set the desired cook time. Press START.
4. Press OPTIONS. Three tones will sound. Then press “7.” “SAb” will appear in the display.

#### **To Adjust Temperature (When Sabbath Mode is Running):**

1. Press BAKE.
2. Press the number keypad as instructed by the scrolling text to select the new temperature.  
**NOTE:** The temperature adjustment will not appear on the display, and no tones will sound. The scrolling text will be shown on the display as it was before the keypad was pressed.
3. Press START.

#### **To Deactivate Sabbath Mode:**

Press OPTIONS, and then press “7” to return to regular baking, or press OFF to turn off the range.

### **Aluminum Foil**

**IMPORTANT:** To avoid permanent damage to the oven bottom finish, do not line the oven bottom with any type of foil or liner. For best cooking results, do not cover entire oven rack with foil because air must be able to move freely.

### **Positioning Racks and Bakeware**

**IMPORTANT:** To avoid permanent damage to the porcelain finish, do not place food or bakeware directly on the oven door or bottom.

#### **Bakeware**

To cook food evenly, hot air must be able to circulate. Allow 2" (5 cm) of space around bakeware and oven walls. Make sure that no bakeware piece is directly over another.

#### **Racks**

- Position racks before turning on the oven.
- Do not position racks with bakeware on them.
- Make sure racks are level.

To position a rack, pull it out to the stop position, raise the front edge, and then lift out. Use the following illustration and charts as a guide.

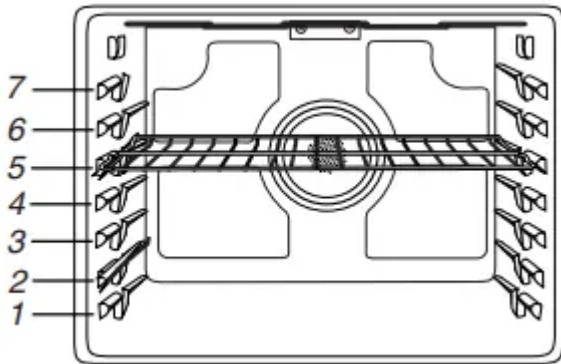

The oven has 7 positions for a flat rack, as shown in the previous illustration and the following table.

Flat Rack Position	Type of Food
7	Broiling/searing meats, hamburgers, steaks
6	Broiled meats, poultry, fish
3 or 4	Most baked goods, casseroles
2	Roasted meats
1	Large roasts or poultry

For hamburger patties to have a well-seared exterior and a rare interior, use a flat rack in rack position 7. Side 1 should cook for approximately 2½ to 3½ minutes. Side 2 should cook for approximately 4 to 5 minutes. Expect a moderate degree of smoke when broiling.

**IMPORTANT:** If your model has a Max Capacity Rack, the recessed ends must be placed in the rack position above the desired position of the food. See the following illustration.

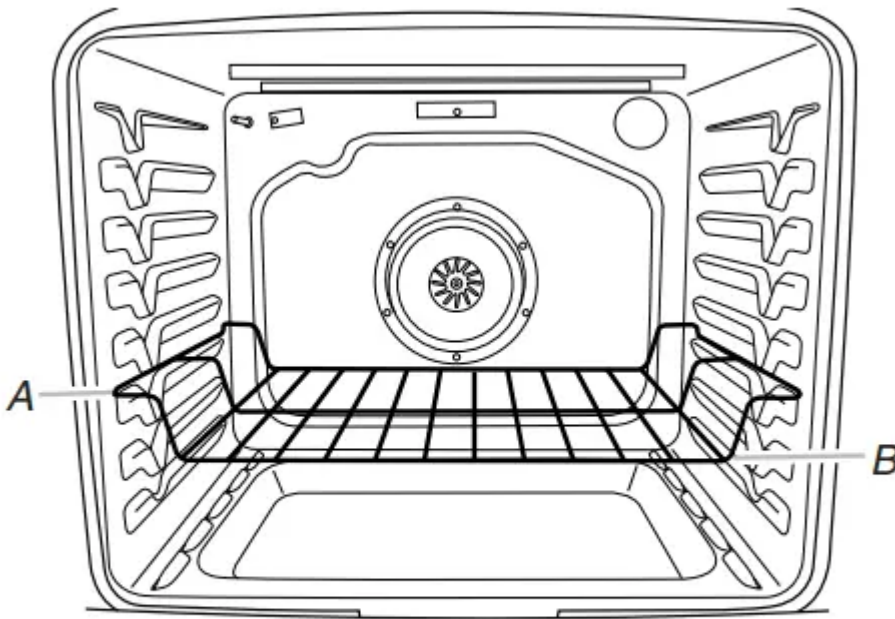

*A. Ends of rack in position 3  
B. Food in position 2*

**IMPORTANT:** These rack positions are for flat racks. If a Max Capacity Rack is used, the rack position must be adjusted as shown in the previous figure.

**Multiple Rack Cooking**

2-rack: Use rack positions 2 and 5 for regular baking.

2-rack (convection only): Use rack positions 2 and 5.

3-rack (true convection only): Use rack positions 2, 4 and 6.

**Baking Cookies and Layer Cakes on 2 Racks Baking Layer Cakes**

For best results when baking cakes on 2 racks, use racks 2 and 5 with the Bake function. Place the cakes on the racks as shown.

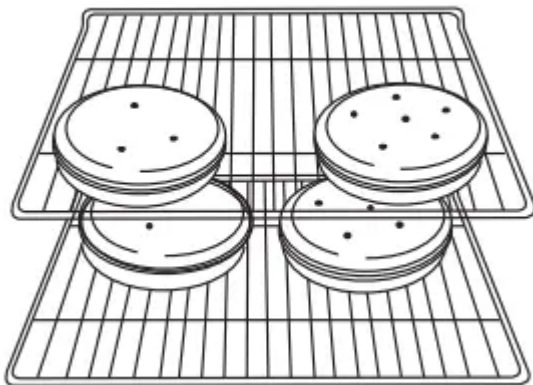

**Baking Cookies**

For best results baking 2 racks of cookies, use racks 2 and 5 with Convection Bake.



## Oven Vent

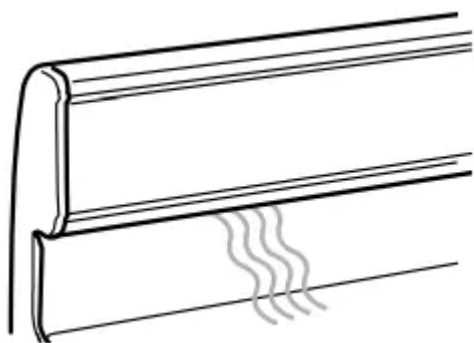

The oven vent releases hot air and moisture from the oven, and should not be blocked or covered. Blocking or covering the oven vent will cause poor air circulation, affecting cooking and cleaning results. Do not set plastics, paper or other items that could melt or burn near the oven vent.

## Baking and Roasting

### Preheating

When beginning a Bake, Convection Bake or Convection Roast cycle, the oven will begin preheating after Start is pressed. The oven will take approximately 12 to 15 minutes to reach 350°F (177°C) with all of the oven racks provided with your oven inside the oven cavity.

Higher temperatures will take longer to preheat. The preheat cycle rapidly increases the oven temperature.

The actual oven temperature will go above your set temperature to offset the heat lost when your oven door is opened to insert food. This ensures that when you place your food in the oven, the oven will begin at the proper temperature. Insert your food when the preheat tone sounds.

Do not open the door during preheat before the tone sounds.

### Oven Temperature

While in use, the oven elements will cycle on and off as needed to maintain a consistent temperature, but they may run slightly hot or cool at any point in time due to this cycling. Opening the oven door while in use will release the hot air and cool the oven which could impact the cooking time and performance. It is recommended to use the oven light to monitor cooking progress.

**NOTE:** On models with convection, the convection fan may run in the non-convection bake mode to improve oven performance.

Temperature Management System

The Temperature Management System electronically regulates the oven heat levels during preheat and bake to maintain a precise temperature range for optimal cooking results. The bake and broil elements or burners cycle on and off in intervals. On convection range models, the fan will run while preheating and may be cycled on and off for short intervals during Bake to provide the best results. This feature is automatically activated when the oven is in use.

Before baking and roasting, position racks according to the “Positioning Racks and Bakeware” section. When roasting, it is not necessary to wait for the oven preheat cycle to end before putting food in unless it is recommended in the recipe.

## Broiling

Leave the door open 6" (15 cm) at the broil stop position to ensure proper broiling temperature. Preheat the oven for 5 minutes before putting food in unless recommended otherwise in the recipe. Position food on grid in a broiler pan, and then place it in the center of the oven rack.

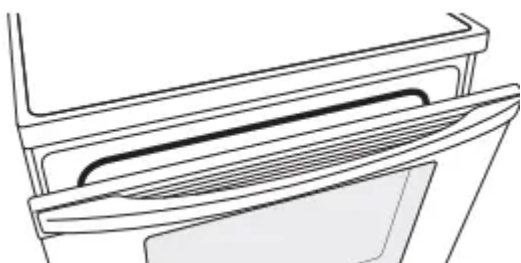

**NOTE:** Odors and smoke are normal the first few times the oven is used or if the oven is heavily soiled.

Changing the temperature when broiling allows more precise control when cooking. The lower the broil setting, the slower the cooking. Thicker cuts and unevenly shaped pieces of meat, fish and poultry may cook better at lower broil settings. Use racks 6 or 7 for broiling. Refer to the “Positioning Racks and Bakeware” section for more information.

On lower settings, the broil element will cycle on and off to maintain the proper temperature.

- For best results, use a broiler pan and grid. It is designed to drain juices and help avoid spatter and smoke.

## Convection Cooking

In a convection oven, the fan-circulated hot air continually distributes heat more evenly than the natural movement of air in a standard thermal oven. This movement of hot air helps maintain a consistent temperature throughout the oven, cooking foods more evenly, crisping surfaces while sealing in moisture and yielding crustier breads.

During convection cooking, the bake, broil and convection (true convection only) elements cycle on and off in intervals to maintain the oven temperature, while the fan circulates the hot air.

If the oven door is opened during convection cooking, the fan will turn off immediately. It will come back on when the oven door is closed.

**NOTE:** The oven door must be closed for convection broiling.

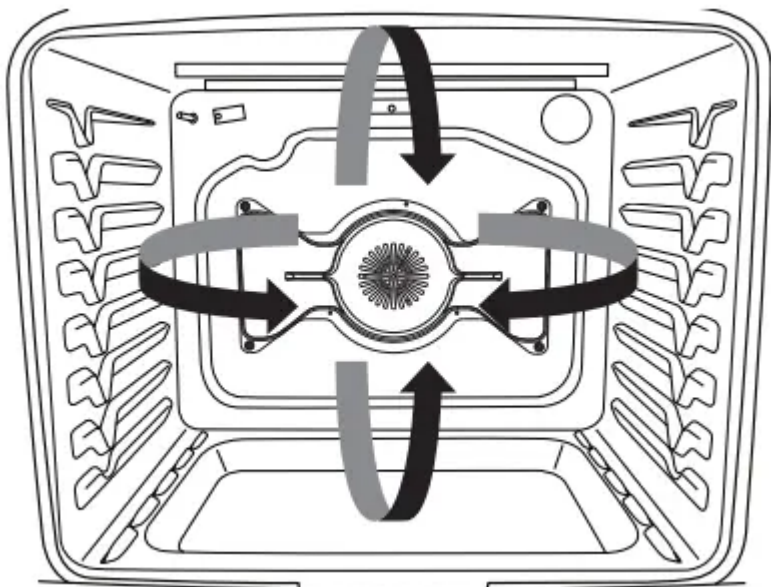

Position the racks according to the “Positioning Racks and Bakeware” section before starting convection cooking.

With convection cooking, most foods can be cooked at a lower temperature for a shorter length of time. These adjustments can be made using the following chart or by using the EasyConvect™ Conversion feature on your range.

Setting	Guidelines
CONVECT BAKE	Reduce the standard baking temperature 25°F (15°C).
CONVECT ROAST	Use standard recipe temperature. Cooking time may be reduced by 15% to 30% with Convection Roast so the food should be checked for doneness early
CONVECT BROIL	Use standard recipe temperature. Cooking time may be reduced so the food should be checked for doneness early.

### **Bow Tie True Convection with T.H.E.™ Element**

True convection adds an electric element around the convection fan to enhance the cooking performance. This feature enables 3-rack baking in your range. Use the following Convection Options chart as a guide.

### **Convection Options**



Setting	Foods
CONVECT BAKE	Single or multiple-rack baking for cookies, biscuits, breads, casseroles, tarts, tortes.
CONVECT ROAST	hole chicken or turkey, vegetables, pork roasts, beef roasts.
CONVECT BROIL	Thicker cuts or unevenly shaped pieces of meat, fish or poultry

### EasyConvect™ Conversion

Convection cooking temperatures and times can differ from those of standard cooking. Depending upon the selected category, EasyConvect™ conversion automatically reduces the standard recipe temperature and/or time you input for convection cooking. Foods are grouped into 4 general categories. Choose the category most appropriate for the food to be cooked. Use the following chart as a guide

Setting	Foods
MEATS	Chicken: whole and pieces Meat loaf, Roasts: pork, beef and ham (Turkey and large poultry are not included because their cook time varies.)
BAKED GOODS	Biscuits, Breads: quick and yeast Cakes and Cookies Casseroles
PIZZA	Fresh pizza, Frozen pizza
OTHER	Frozen convenience foods: french fries, nuggets, fish sticks, lasagna

To Use:

**NOTE:** For best results, preheat your oven to the desired temperature prior to using Easy Convect™ Conversion. After preheating is complete, press OFF before using EasyConvect™ Conversion.

1. Press the EASY CONVECT key for the desired option (MEATS, BAKED GOODS, PIZZA or OTHER).
2. Press START.

3. Press the number keys to enter standard cook temperature, and then press START.
4. Press the number keys to enter standard cook time, and then press START.
5. Place the food in the oven. Check food for doneness before the stop time is reached. If food will not be done when the stop time is reached, add more cooking time before time elapses. At the end of the stop time, the oven will automatically turn off.
6. Press OFF when finished.
7. Remove food from the oven.

## Proofing Bread

Proofing bread prepares the dough for baking by activating the yeast. Follow the recipe directions as a guide. Standard Proof should be used for fresh dough, thawed dough, and for the first and second rise. Rapid Proof (on some models) operates at a slightly higher temperature than Standard Proof, and it can be used for the second rise of formed dough.

### To Proof:

Before first proofing, place the dough in a lightly greased bowl and cover loosely with wax paper, coated with shortening. Place in position 2, and then close the oven door.

1. Press BREAD PROOF until the desired proof is displayed (“Standrd” or “Rapid”).
2. Press START. Let the dough rise until nearly doubled in size. Proofing time may vary depending on dough type and quantity.
3. Press OFF when finished proofing.

Before second proofing, shape the dough, place it in baking pan(s) and then cover loosely. Follow the same placement and control steps above. Before baking, remove the cover.

**NOTE:** If the oven temperature is greater than 120°F (49°C), the display will indicate “Oven Cooling” until the temperature is below 120°F (49°C).

## Cook Time

### WARNING: Food Poisoning Hazard

- Do not let food sit in oven more than one hour before or after cooking.
- Doing so can result in food poisoning or sickness.

### To Set a Timed Cook:

1. Press BAKE, CONVECT BAKE, CONVECT ROAST or CONVECT BROIL.
2. Press the number keypads to set the desired temperature. If the temperature entered is not in the range of the temperatures allowed, the minimum or maximum allowed temperature will be displayed. Enter a temperature in the allowable range.
3. Press COOK TIME.

4. Press the number keypads to enter the length of time to cook.
5. Press START. The display will count down the time. When the time ends, the oven will shut off automatically. The temperature and/or time setting can be changed at any time by repeating steps 2 through 5.
6. Press OFF to clear the display.

**NOTE:** The time setting for any timed cooking function, including EasyConvect™ Conversion, can be adjusted by following the previous steps 3 through 5.

#### **To Set a Delayed Timed Cook:**

1. Press DELAY START.
2. Press the number keypads to enter the number of hours and/or minutes you want to delay the start time.
3. Press BAKE, CONVECT BAKE, CONVECT ROAST or CONVECT BROIL.
4. Press the number keypads to set the desired temperature. If the temperature entered is not in the range of the temperatures allowed, the minimum or maximum allowed temperature will be displayed. Enter a temperature in the allowable range.
5. Press START or COOK TIME.
6. Press number keypads to enter the length of time to cook.
7. Press START.

When the start time is reached, the oven will automatically turn on. The temperature and/or time settings can be changed after the delay countdown by repeating steps 1 through 7.

When resetting the time and temperature, it is necessary to press Start between steps 4 and 5 to continue making changes. When the set cook time ends, the oven will shut off automatically.

8. Press OFF to clear the display

## **RANGE CARE**

### **Clean Cycle**



AquaLift® Technology is an innovative cleaning solution that utilizes heat and water to release baked-on spills from the oven in less than 1 hour. This new cleaning technology is a low-heat, odor-free alternative to traditional self-cleaning options.

Allow the oven to cool to room temperature before using the Clean cycle. If your oven cavity is above 200°F (93°C), "Oven Cooling" will appear in the display, and the Clean cycle will not be activated until the oven cavity cools down.

#### To Clean:

1. Remove all racks and accessories from the oven cavity and wipe excess soil. Use a plastic scraper to remove easily removed soils.

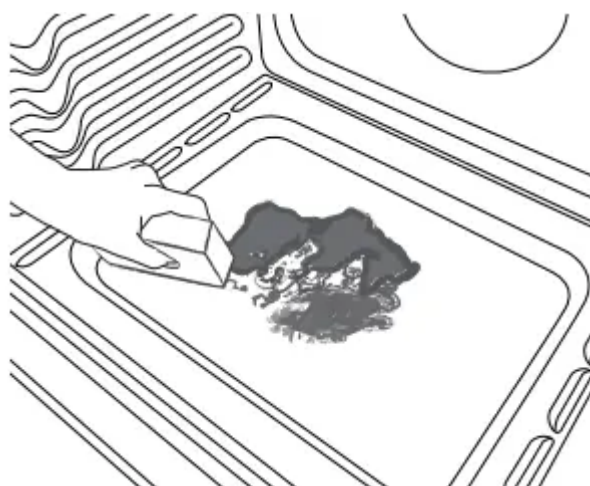

2. Pour 2 cups (16 oz [500 mL]) of distilled or filtered water onto the bottom of the empty oven and close the oven door.

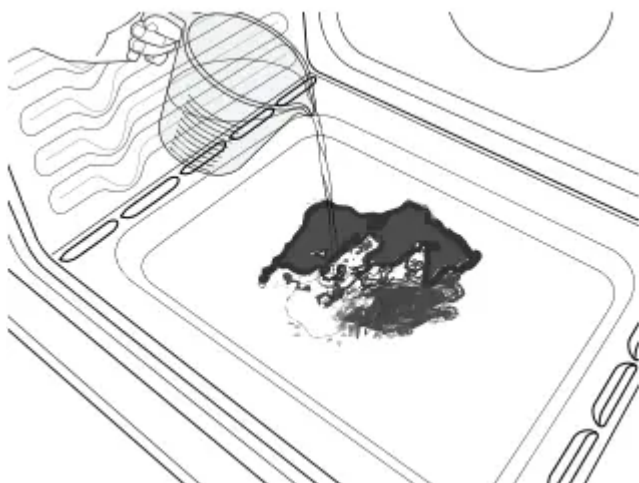

**IMPORTANT:** Do not use chemicals or other additives with the water. Do not open the oven door during the Clean cycle. The water on the oven bottom is hot.

3. Press AQUALIFT SELF CLEAN and then START on the oven control panel.
4. Allow 40 minutes for cleaning and cool down. A beep will sound when the Clean cycle is complete.

5. Press OFF at the end of the cycle. Off may be pressed at any time to stop the Clean cycle.

6. Remove the residual water and loosened soils with a sponge or cloth immediately after the Clean cycle is complete. Much of the initial 2 cups (16 oz [500 mL]) of water will remain in the oven after the cycle is completed. If additional soils remain, leave a small amount of water in the oven bottom to assist with the cleaning.

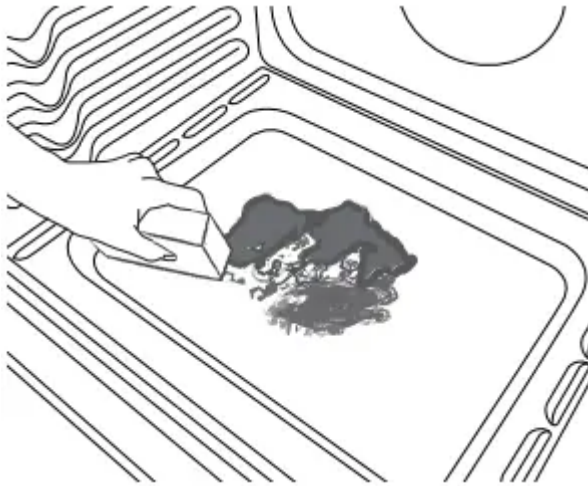

7. If any soils remain, remove them with a non-scratch scrubbing sponge or plastic scraper. Additional Clean cycles may be run to help remove the stubborn soils.

**IMPORTANT:** Do not use oven cleaners. The use of chemicals, including commercial oven cleaners or metal scouring pads, may cause permanent damage to the porcelain surface of the oven interior.

**NOTES:**

- The range should be level to ensure that the entire surface of the bottom of the oven cavity is covered by water at the beginning of the Clean cycle.
- For best results, use distilled or filtered water. Tap water may leave mineral deposits on the oven bottom.
- Before removing the residual water and loosened soils at the end of the Clean cycle, insert a cloth or paper towel between the lower edge of the oven door and the front frame to keep water from spilling onto the front of the range and the floor.
- Soil baked on through several cooking cycles will be more difficult to remove with the Clean cycle.
- Nonabrasive scrub sponges or eraser style cleaning pads (without cleaners) can be effective for cleaning the oven cavity walls, oven door and oven bottom for difficult soils. For best results, moisten the pads and sponges before use.
- Run an additional Clean cycle for stubborn soils.

- affresh® Kitchen and Appliance Cleaner and affresh® Cooktop Cleaner may be used to clean the oven bottom, walls and door when the oven has finished the cycle and returned to room temperature. If affresh® Cooktop Cleaner is used, wiping out the oven with distilled water is recommended as well.

## **General Cleaning**

**IMPORTANT:** Before cleaning, make sure all controls are off and the oven and cooktop are cool. Always follow label instructions on cleaning products.

Soap, water and a soft cloth or sponge are suggested first unless otherwise noted.

### **EXTERIOR PORCELAIN ENAMEL SURFACES (on some models)**

Food spills containing acids, such as vinegar and tomato, should be cleaned as soon as the entire range is cool. These spills may affect the finish.

#### **Cleaning Method:**

- Glass cleaner, mild liquid cleaner or nonabrasive scrubbing pad: Gently clean around the model/serial/rating plate because scrubbing may remove numbers.
- affresh® Kitchen and Appliance Cleaner Part Number W10355010 (not included)

### **STAINLESS STEEL (on some models)**

**NOTE:** To avoid damage to stainless steel surfaces, do not use soap-filled scouring pads, abrasive cleaners, Cooktop Cleaner, steel-wool pads, gritty washcloths or abrasive paper towels. Damage may occur to stainless steel surfaces, even with one-time or limited use.

#### **Cleaning Method:**

Rub in direction of grain to avoid damaging.

- affresh® Stainless Steel Cleaner Part Number W10355016:

### **METALLIC PAINT (on some models)**

Do not use abrasive cleaners, cleaners with bleach, rust removers, ammonia or sodium hydroxide (lye) because paint surface may stain.

### **CERAMIC GLASS (on some models)**

#### **Cleaning Method:**

Use affresh® Cooktop Cleaner Part Number W10355051, Cooktop Cleaning Pads Part Number W10391473 and Cooktop Scraper Part Number WA906B to clean and remove stains from the cooktop. Use Cooktop Protectant Part Number 31463A regularly to avoid stain buildup, pitting and

scratching, while conditioning the cooktop for easier future cleaning. These can be ordered as accessories. The Cooktop Scraper uses razor blades. Store razor blades out of the reach of children.

Do not use steel wool, abrasive powder cleansers, chlorine bleach, rust remover or ammonia because damage may occur.

### **Light to moderate soil**

- Can be cleaned with damp paper towels or sponge. Light stains should be addressed with cleaner and cleaning pad. Sugary spills (jellies, candy, syrup)
- Cooktop Scraper: Scrape off sugary spills while the cooktop is still warm. You may want to wear oven mitts while cleaning the cooktop.
- affresh® Cooktop Cleaner and Cooktop Cleaning Pads: Clean as soon as cooktop has cooled down. Rub product into surface with a Cooktop Cleaning Pad. Continue rubbing until white film disappears.

### **Heavy soil, dark streaks, specks and discoloration**

Clean with affresh® Cooktop Cleaner or nonabrasive cleaner and cleaning pad.

### **Burned-on soil**

- affresh® Cooktop Cleaner or nonabrasive cleanser with Cooktop Cleaning Pads:

Clean as soon as cooktop has cooled down. Rub product into soil with a Cooktop Cleaning Pad. Continue rubbing until white film disappears.

### **Metal marks from aluminum and copper**

- affresh® Cooktop Cleaner and Cooktop Cleaning Pads:

Clean as soon as cooktop has cooled down. Rub product into surface with a Cooktop Cleaning Pad. Continue rubbing until white film disappears. The marks will not totally disappear, but after many cleanings they will become less noticeable.

### **Tiny scratches and abrasions**

- affresh® Cooktop Cleaner and Cooktop Cleaning Pads:

Clean as soon as cooktop has cooled down. Rub product into surface with a Cooktop Cleaning Pad. Continue rubbing until white film disappears. Scratches and abrasions do not affect cooking performance, and after many cleanings they will become less noticeable.

## **COOKTOP CONTROLS**

To avoid damage to the cooktop controls, do not use steel wool, abrasive cleansers or oven cleaner.

To avoid damage, do not soak knobs.

When replacing knobs, make sure knobs are in the Off position.

On some models, do not remove seals under knobs.

**Cleaning Method:**

- Soap and water: Pull knobs straight away from control panel to remove.

**CONTROL PANEL AND OVEN DOOR EXTERIOR**

To avoid damage to the control panel, do not use abrasive cleaners, steel-wool pads, gritty washcloths or abrasive paper towels.

**Cleaning Method:**

- Glass cleaner and soft cloth or sponge: Apply glass cleaner to soft cloth or sponge, not directly on panel.
- affresh® Kitchen and Appliance Cleaner Part Number W10355010 (not included)

**OVEN RACKS**

Cleaning Method:

Steel-wool pad.

For racks that have discolored and are harder to slide, a light coating of vegetable oil applied to the rack guides will help them slide.

**STORAGE DRAWER OR WARMING DRAWER (on some models)**

Check that storage drawer or warming drawer is cool and empty before cleaning.

**Cleaning Method:**

- Mild detergent.

**OVEN CAVITY**

Use AquaLift® Technology regularly to clean oven spills. Do not use oven cleaners.

Food spills should be cleaned when oven cools. At high temperatures, foods react with porcelain and staining, etching, pitting or faint white spots can result.

**Cleaning Method:**

- Clean cycle: See “Clean Cycle” first.



## Oven Light

The oven light is a standard 40-watt appliance bulb. Before replacing, make sure the oven and cooktop are cool and the control knobs are in the Off position.

### To Replace:

1. Unplug range or disconnect power.
2. Turn the glass bulb cover in the back of the oven counterclockwise to remove.
3. Turn bulb counterclockwise to remove from socket.
4. Replace bulb by turning clockwise.
5. Replace bulb cover by turning clockwise.
6. Plug in range or reconnect power.

## Appliance Outlets

The 120-volt appliance outlet located on the control console may be used to run portable appliances placed on countertops beside the range.

The outlet operates independently and is not affected by range control settings.

**NOTE:** Do not place portable appliances on the cooktop. Damage to the portable appliance could result if the cooktop is hot.

### Appliance Outlet Circuit Breaker:

The circuit breaker for the appliance outlet on your range is located next to the outlet. It is rated for 12 amps.

If the circuit breaker trips, it can be reset by pressing the switch. A delay of several minutes may be required for the circuit breaker to cool before it will reset.

# PROBLEM SOLVER



PROBLEM	POSSIBLE CAUSES AND/OR SOLUTIONS
Nothing will operate	<p>Power supply cord is unplugged - Plug into a grounded outlet.</p> <p>Energy Save is active, and the display is blank - Press any key on the control to display the time of day.</p> <p>Household fuse is blown, or a circuit breaker is tripped - Replace the fuse or reset the circuit breaker. If the problem continues, call an electrician.</p> <p>The control displays an F9 or F9 E0 error code - The electrical outlet in the home may be miswired. Contact a qualified electrician to verify the electrical supply.</p>
Cooktop will not operate	<p>The control knob is not set correctly - Push in knob before turning to a setting.</p> <p>On ceramic glass models, the oven control lockout is set - See the "Control Lock" keypad feature in the "Feature Guide" section.</p>
Excessive heat around cookware on cooktop	<p>Cookware is not the proper size - Use cookware about the same size as the surface cooking area, element or surface burner. Cookware should not extend more than ½" (1.3 cm) outside the cooking area.</p>
Cooktop cooking results not what expected	<p>Control knob set to incorrect heat level - See the "Cooktop Use" section.</p> <p>Range is not level - Level the range.</p>
Cooktop element cycles on and off on High setting	<p>Element cycling due to a temperature limiter - This is normal operation. The element may cycle on and off to keep the cooktop from overheating.</p>
Oven will not operate	<p>Delay Start is set - See the "Cook Time" section.</p> <p>Control Lock is on - Press and hold the "0" key for 3 seconds to unlock.</p> <p>Control is in Demo Mode - See the "Electronic Oven Controls" section. Demo Mode is used for display models in a showroom.</p>



PROBLEM	POSSIBLE CAUSES AND/OR SOLUTIONS
	Electronic oven control set incorrectly - See the "Electronic Oven Controls" section.
Oven temperature too high or too low	Oven temperature needs adjustment - See "Oven Temperature Control" in the "Electronic Oven Controls" section.
Oven indicator lights flash	Power to range is turned on or restored - See "Control Display" in the "Electronic Oven Controls" section. If the indicator lights keep flashing, call for service.
Display shows messages	<p>Power failure (display shows flashing time) - Press OFF to clear the display. On some models, reset the clock, if needed. See the "Clock" keypad feature in the "Feature Guide" section.</p> <p>Error code (display shows letter followed by number) - Depending on your model, press OFF to clear the display. See "Control Display" in the "Electronic Oven Controls" section. If it reappears, call for service.</p>
Clean cycle did not work on all spills	Several cooking cycles between Clean cycles or spills on oven walls and doors - Run additional Clean cycles. Use the AquaLift® Technology Cleaning Kit. affresh® Kitchen and Appliance Cleaner or affresh® Cooktop Cleaner can be used for stubborn soils.
Mineral deposits are left on the oven bottom after the Clean cycle	<p>Tap water was used in the Clean cycle - Use distilled or filtered water in the Clean cycle.</p> <p>To remove deposits, use a cloth soaked with vinegar. Then use a cloth dampened with water to thoroughly remove any vinegar residue.</p> <p>Range is not level - Mineral deposits will collect on dry areas of the oven bottom during the Clean cycle. Level the range. See the Installation Instructions.</p> <p>To remove deposits, use a cloth soaked with vinegar. Then use a cloth dampened with water to thoroughly remove any vinegar residue.</p>



PROBLEM	POSSIBLE CAUSES AND/OR SOLUTIONS
Oven cooking results not what expected	<p>Range is not level - Level the range.</p> <p>The set temperature was incorrect - Double-check the recipe in a reliable cookbook.</p> <p>Oven temperature needs adjustment - See “Oven Temperature Control” in the “Electronic Oven Controls” section.</p> <p>Oven was not preheated - See the “Baking and Roasting” section.</p> <p>Racks were positioned improperly - See the “Positioning Racks and Bakeware” section.</p> <p>Not enough air circulation around bakeware - See the “Positioning Racks and Bakeware” section.</p> <p>Batter distributed unevenly in pan - Check that batter is level in the pan.</p> <p>Darker browning of food caused by dull or dark bakeware - Lower oven temperature 25°F (15°C) or move rack to a higher position in the oven.</p> <p>Lighter browning of food caused by shiny or light colored bakeware - Move rack to a lower position in the oven.</p> <p>Incorrect length of cooking time was used - Adjust cooking time.</p> <p>Oven door was not closed - Be sure that the bakeware does not keep the door from closing.</p> <p>Oven door was opened during cooking - Oven peeking releases oven heat and can result in longer cooking times.</p> <p>Rack is too close to bake burner, making baked items too brown on bottom - Move rack to higher position in the oven.</p> <p>Pie crusts browning too quickly - Use aluminum foil to cover the edge of the crust and/or reduce baking temperature.</p>

**Warning**



This content is compiled from multiple sources and is provided for reference purposes only. It may not be complete or fully applicable to all situations. If you are unable to resolve your issue, please contact the product manufacturer or an authorized service provider for official support.

---

Document generated by [ManualsFile](#)

