

Overview



- 1 Dirt Bin and Filter
- 2 Top
- 3 Laser Cover
- 4 Start Button
- 5 Info LED
- 6 Battery LED
- 7 Handle
- 8 Front Bumper
- 9 Boundary Marker
- 10 Charge Base
- 11 Brush
- 12 Wall Following Sensor Window
- 13 Side Brush
- 14 Drop Sensor Window
- 15 Brush Guard
- 16 Battery Door
- 17 Wheels
- 18 Charging Contacts
- 19

19 Cleaning Too

INFO LED is used for:

- Wi-Fi connection status
- Cleaning status
- Errors

BATTERY LED is used to show:

- Charge state
- Battery Errors

Requirements: You need Wi-Fi, a phone or tablet running iOS 10 or greater, or Android 4.2 or greater, and a Neato account (free) in order to use some features.

Important Items

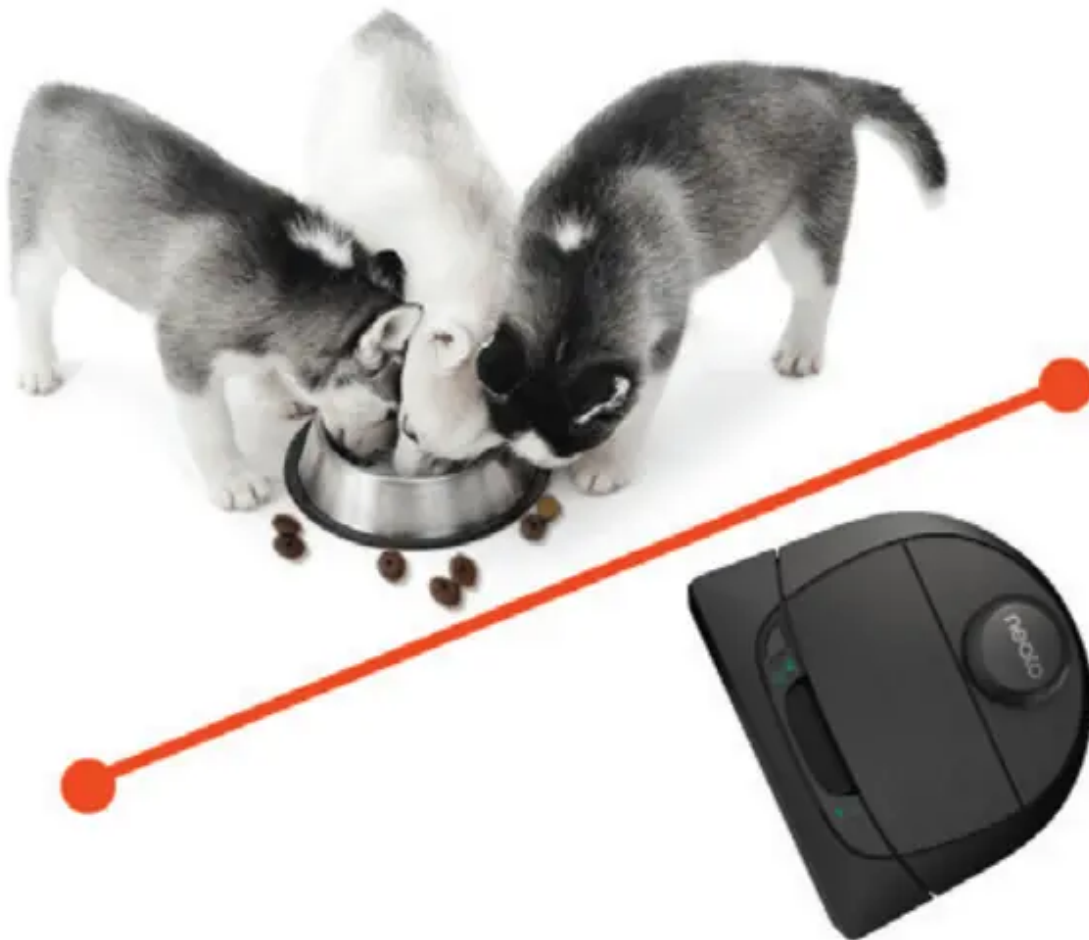

Keep your robot away from liquids and wet areas. Move or cover pet bowls and plant trays.

Clear the area of small items such as toys and clothing

Tie up wires, curtains, and other low hanging items.

Keep your Neato robot inside the house. It was not designed for outdoor cleaning or freezing temperatures.

Please observe your Neato robot during the first few cleaning runs, and make any adjustments to the cleaning environment to optimize navigation. Also, while Neato robots have a smart navigation system that avoids obstacles, the robot may occasionally bump into furniture, objects, pets, and people.

Neato robots will not always avoid small objects (for example, socks or jewelry) or cords on the floor. Therefore, if you have special objects that could potentially be damaged by bumping, remove these objects from the room, use boundary markers, or add No-Go Line on the Neato app.

Similarly, the Neato robot's rotating brush operates like a regular upright vacuum cleaner, so do not use the Neato robot on floors or rugs (e.g., with fringes) that you would not use a regular upright vacuum on.

If the area to be cleaned contains a cliff, drop, balcony, fireplace, stairs or other area where the vacuum could travel/fall that represents danger, place a physical barrier to prevent travel in that area to ensure safety. The drop sensors and boundary markers are to help the robot during cleaning but should not be solely relied upon to avoid a potential dangerous situation. Neato Robotics is not responsible for any damage to furniture, rugs or flooring.

Important Tips

To keep your robot out of places you don't want it to go, set down boundary markers included in specific models, but Neato Boundary Markers are compatible with all Neato robots), or set "No-Go" Lines in MyFloorPlan.

You can use scissors to cut boundary markers to a shorter length.

You can use removable tape to keep boundary markers flat on the floor.

To do a Reset of the Neato robot, press and hold the Start button for 15 seconds, and all the lights will turn off. Press Start button once more to turn the robot back on.

The Combo brush offers superior pick-up of pet hair and is ideal for homes with multiple types of flooring.

Shiny surfaces and black floors might cause navigation issues.

Before connecting your robot to your Neato account, view the How-To Video online at [supportneatorobotics](https://supportneatorobotics.com)

Start Button & LED Lights

BATTERY LED

ROBOT IS:	LED COLOR	WHAT IT MEANS
Cleaning	Solid Green	Battery level is normal
	Solid Yellow	Battery level is low and must be charged before a new cleaning can be started
	Solid Red	Battery level is low and robot must return to charge base
Charging	Green (Solid or pulsing)	Battery is charging and robot can start cleaning
	Pulsing Yellow	Battery is charging and must complete before cleaning can start
	Pulsing Red	Battery level is low and must be charged before a new cleaning can be started

* **NOTE:** if LED light is Blinking Red or Solid Red, your robot needs robot maintenance or your robot has a navigation issue. Please check the troubleshooting section of this guide.

Start Button & LED Lights

How Neato Works

HOUSE CLEANING

In normal operation, the Neato robot comes off of its base, explores its surroundings, and starts cleaning. It starts cleaning in sections approximately 15'x15' depending on layout and furniture in the room. It will continue to clean section by section until the entire area is cleaned.

Your Neato robot will also try to clean one room fully before moving on to the next, assuming it can detect your doorways. If it cleans a partial room, your Neato robot will come back to complete the room before finishing the job.

QUICK BOOST CHARGING

Sometimes the area to be cleaned is very large and the robot may need to recharge before finishing the job. With quick boost, it calculates how much battery is needed to complete the job, charges only that amount, so it can go back out quickly to finish the job.

SINGLE ROOM CLEANING

If you just want to clean a single room, you can manually place your robot in the room, press the start button, and close the door. Your Neato robot will clean the room and return to where you originally placed it. When the robot has finished cleaning, please put the robot back on its charge base.



MOVING A ROBOT MID-CLEANING

It is not recommended to pick up your robot and move it mid-cleaning. It can become disoriented, not follow its normal smart behavior, and have difficulty finding its charge base. If you pick up your robot, put it back down within 1 foot of where you picked it up for best results.

Using the Neato App

Follow the instructions in the Quick Start Guide to connect your robot to the Neato app.

It is recommended that you set up your robot to work with the Neato app to get the best experience and access to all of the features.

Benefits of using the Neato app:

- Neato FloorPlanner with “No-Go” Lines
- Easy access & control
- Start your robot when you are not home
- Easily pause cleaning from the app
- Instant notifications (cleaning complete, alerts, etc.)
- Battery status
- Maintenance alerts and context-sensitive help to keep your robot in top form
- Receive notifications of robot software updates

NOTE It is also possible to start and stop the robot using the Start Button on the robot.

OPERATING THE ROBOT FROM MULTIPLE SMARTPHONES TABLETS

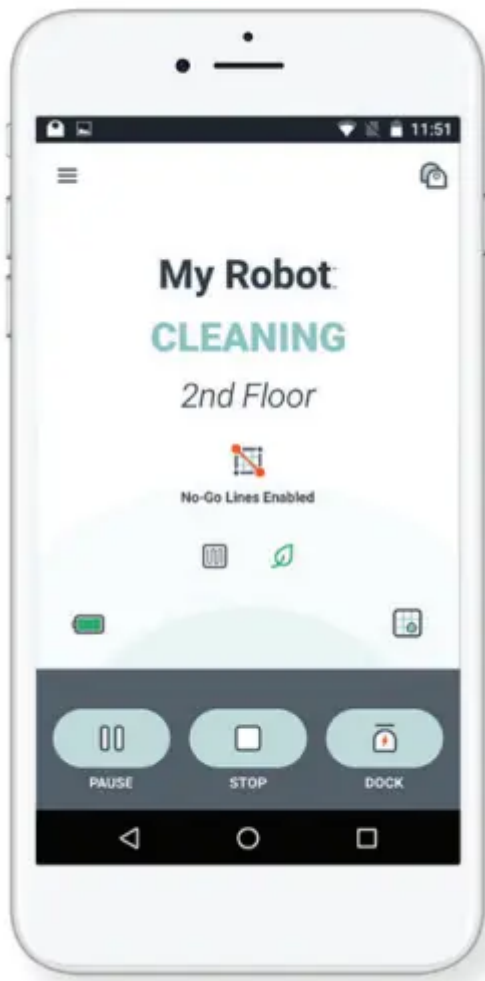

The Neato app can be used by multiple devices in a household to operate the same robot. Just download the Neato app to other smartphones or tablets, and sign in to the same My Neato account using the email and password used to set up the robot.

NOTE Neato Botvac D4 supports 2.4 Wi-Fi networks, channels 1 through 11.

For best results, locate your Wi-Fi router centrally where it can deliver a strong signal throughout the house.

HOUSE CLEANING

To start a House Cleaning, press the Start button in the Neato app, and your Neato robot will clean the entire floor on one level automatically moving from room to room. From the app you can Start, Pause, Resume, Stop, and Return to Start/Base.

NOTE When canceled mid-cleaning, your robot will stop in place. You can ask your robot to return to its base station using the Neato app. If the robot has detected the base, it will attempt to return to base and dock

SPOT CLEANING

To start a Spot Cleaning, select Spot, and press the Start button in the Neato app. Your Neato robot will clean a 7'x7' area.

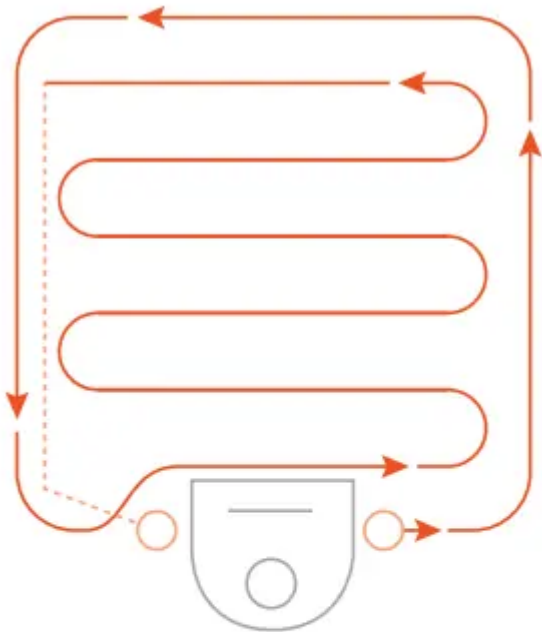

Place your robot centered and facing the area to be cleaned.

SCHEDULING YOUR NEATO ROBOT

Set up a schedule for regular vacuuming. You can set your preferences based on cleaning days and times.

NOTE If you are going away, you can turn the Enable Schedule setting off to put the schedule on hold.

PUSH NOTIFICATIONS

By turning on push notifications in the app, your robot can notify you about its status. Your phone/tablet will display messages such as cleaning complete, alerts, etc.

ROBOT SOFTWARE UPDATES

Keep the software on your robot current. You can initiate a robot software update using the Neato app.

TROUBLESHOOTING YOUR DEVICE

When an error occurs during operation of the robot, you can click the error link in the Neato app to see what it means and what to do. For additional information on troubleshooting your device, please see Help in the app.

SMARTWATCH CAPABLE



If you have an Apple Watch or a Wear OS enabled smartwatch, you can access some features on your watch such as start, stop, and receiving notifications. Your watch needs to be in the vicinity of your smartphone for these features to be accessible. After you have paired your smartwatch with your smartphone, go to the watch app on your smartphone and turn access on to the Neato app to view features on your watch.

Using Your Neato Robot Without the Neato App

HOUSE CLEANING



Press the
Start Button 1 x
for House Cleaning,
2 x for Spot
Cleaning

You can initiate House Cleaning by pressing the Start Button once. Your Neato robot will clean the entire floor on one level automatically moving from room to room.

NOTE: If you press the Start Button in the Neato app and the robot cannot find its location on MyFloorPlan, you will be notified of this and prompted to either cancel or clean anyway. If you select “clean anyway,” the robot will not use MyFloorPlan or respect any “No-Go” Lines, so you will need to use the boundary markers to keep the robot out of any areas you don’t want it to clean.

SPOT CLEANING

You can initiate Spot Cleaning by pressing the Start Button twice. During Spot Cleaning, if you press the Start Button, the robot will pause. If you press it again, it will resume. To cancel the Spot Cleaning, pause the robot and hold down the Start Button for 5 seconds.

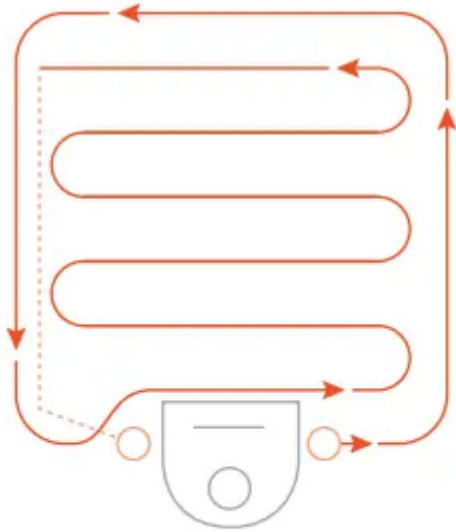

Place your robot
centered and
facing the area
to be cleaned.

FEATURES ONLY AVAILABLE VIA THE NEATO APP

Some features are only available if you connect your robot to the Neato app on your smartphone or tablet. These features include Neato FloorPlanner, scheduling, push notifications, and cleaning statistics.

Cleaning Profiles

When you start a house cleaning with the Neato app, you can select one of the profiles below to determine the robot's cleaning style.

ECO

In the Eco profile, the brush and blower are at a medium setting, allowing the robot to clean a larger area on a single charge. This is the quietest mode.

TURBO

In the Turbo profile, the robot brush and blower are set to high, providing strong suction and a faster rotating brush. Turbo consumes more battery power than Eco.

Extra Care Navigation

Extra Care navigation is useful if you have delicate furniture. When it is enabled, the robot navigates more carefully around objects. It leaves a wider buffer around items like chair legs.

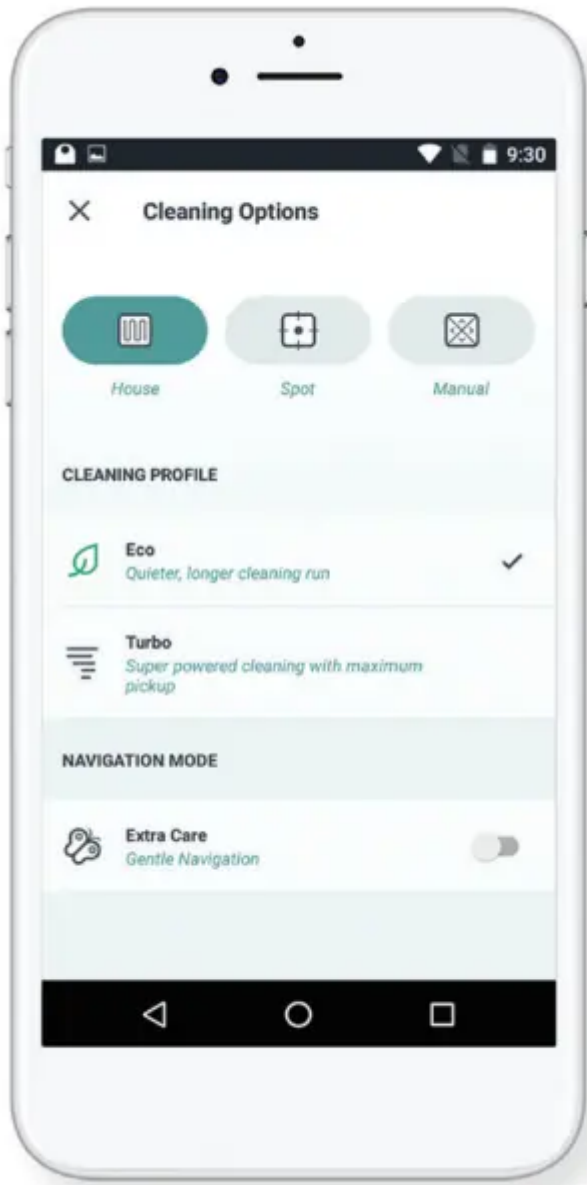

Neato FloorPlanner With “No-Go” Lines

NEATO FLOORPLANNER

Using the Neato app, Neato FloorPlanner allows you to set up virtual boundaries called “No-Go” Lines so you can tell the robot where not to go. This eliminates the need to use physical barriers, including Neato’s Boundary Markers.

	<p>Use the Neato app and the FloorPlanner map of your home to set up virtual boundaries called No-Go Lines so you can tell the robot where not to go.</p> <p>To set up virtual No-Go Lines, please be sure that the Neato App is installed on your selected device, then follow the next steps:</p>
--	---

	<p>Launch the Neato App and tap the “Tri-Bar” symbol in the left upper corner.</p>
<p>Select the “MY FLOOR PLAN” option.</p>	

Tap the “Get Started” button and follow the instructions to allow the robot to do a special cleaning run to create a floor map.

Once the cleaning is complete, you’ll be notified that the robot has created your new floor plan. Give the new floor plan a name and save.

<p>Tap the “ADD NO-GO LINE” icon and draw your boundary line directly on the map.</p> <p>Continue tapping the “ADD NO-GO LINE” button to create multiple boundary lines.</p>		
--	--	--

TIP: Draw No-Go Lines more accurately by zooming into the floor plan. Double tap or use the pinch gesture to zoom. Ensure there are no gaps in the boundaries created with the No-Go Lines.

When finished setting your boundaries, tap the “Save” icon to store your floor plan with virtual No-Go Lines added

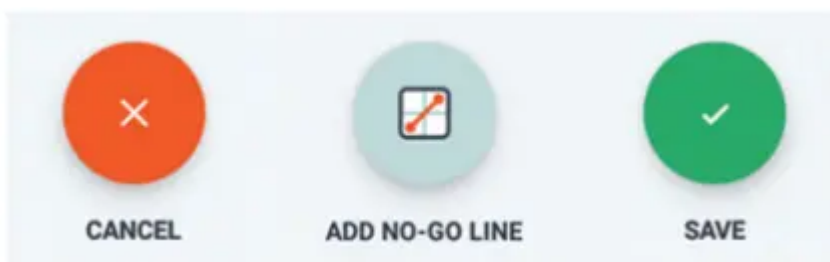

<p>A confirmation prompt will appear, letting you know that “No-Go” lines have been saved.</p> <p>Once saved, your new floor plan with virtual No-Go Lines will become your default map, and be utilized for future cleaning events.</p>		

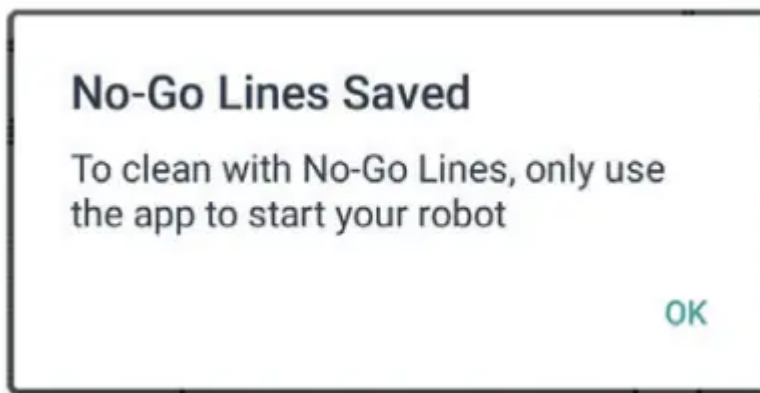

Cleaning with No-Go Lines

To clean with No-Go Lines enabled, the robot must start from the charge base and the cleaning must be initiated from the Neato app. Press the Start button on the app, or schedule a cleaning on the app.

NOTE:

- After each cleaning, tap the , to see a Cleaning Summary which shows where the robot has cleaned on the coverage map.
- To use No-Go Lines, the charge base must stay in the original location where the floor plan was created.
- If cleaning is initiated using the Start button on the robot, Amazon Alexa, Google Home, Chatbots, or IFTTT, it will not adhere to the No-Go Lines boundaries.

Maintaining Your Neato Robot

IMPORTANT

Your robot needs regular maintenance to operate reliably. This means checking/ cleaning the brushes and emptying the dirt bin after every use or as needed, depending on your environment. Failure to do this may cause problems with your robot and impact your robot's performance and void your warranty coverage.

DIRT BIN AND FILTERS

After each use, empty the dirt bin, clean the airways/opening, and filter. To remove the filter, pinch the handle and pull out. Replace the filter every 1 to 2 months or more frequently as needed.

BRUSHES

Remove the side brush, and set aside. Then, remove the brush guard by pulling up on both sides.

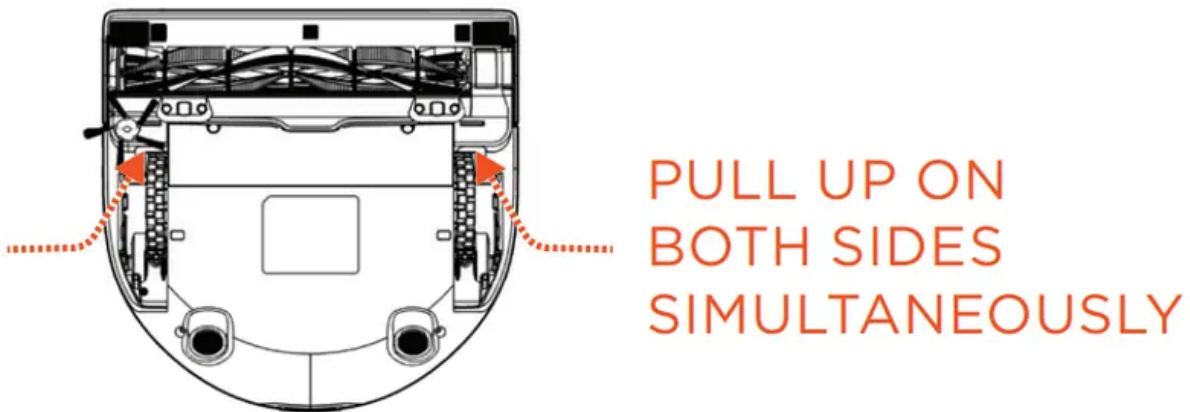

Use the hair/fiber blade to cut, and remove hair from the brush. Remove any debris from the brush ends and inside the brush cavity where the brush sits. Re-insert the brush, and replace the brush guard. It is recommended to clean the brush monthly.



ROBOT TOP

Clean the top of the robot and the area around the laser top with a soft cotton cloth.		
--	--	--

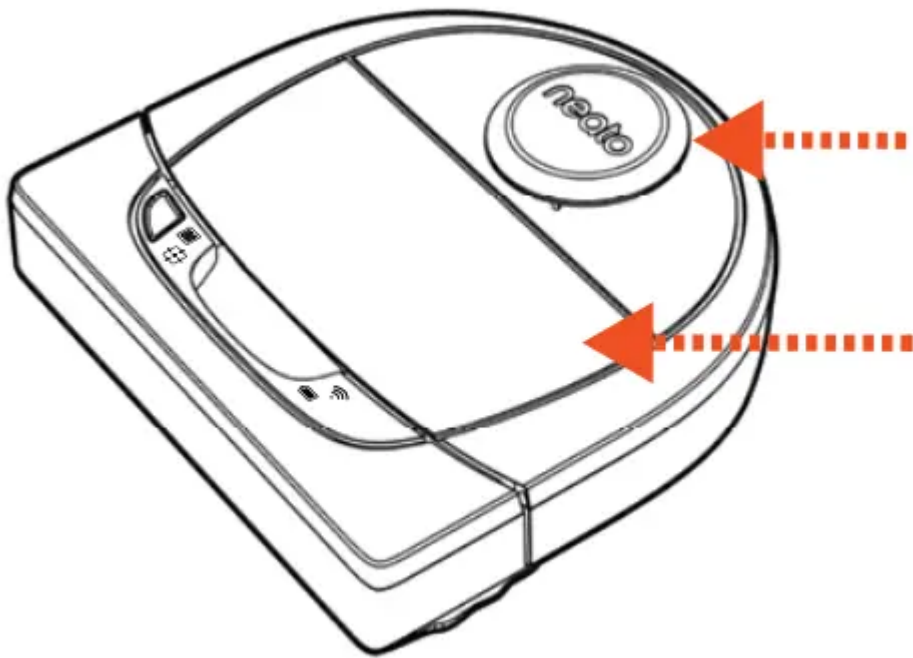

SENSORS

Use a dry cotton swab to clean the two drop sensor windows on the bottom of the robot.

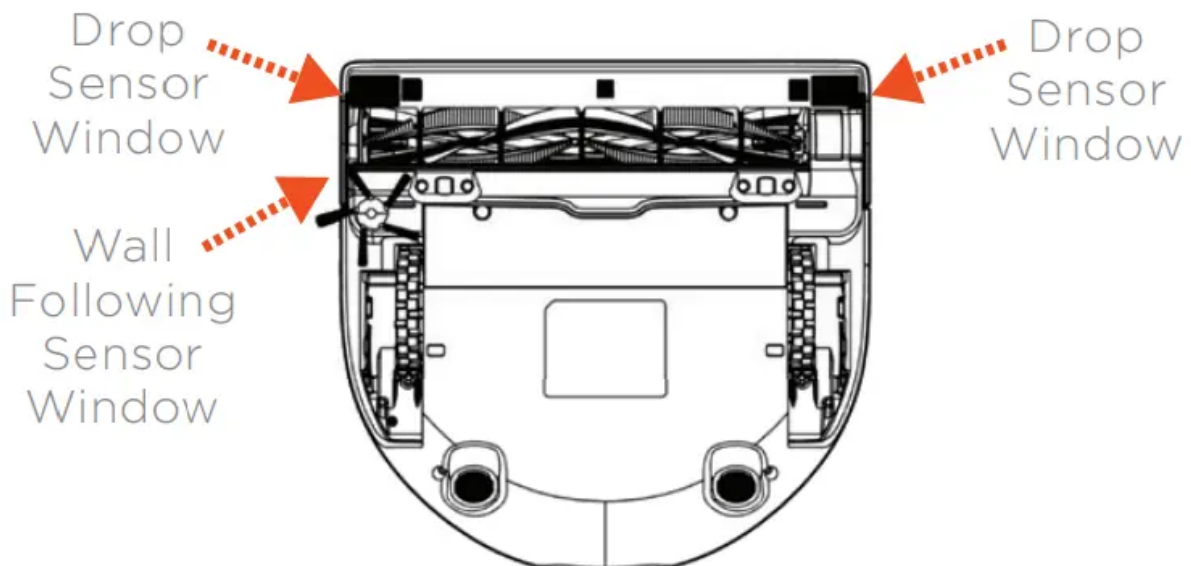

NOTE View the Neato How-To videos online at supportneatorobotics to see how to maintain your robot.

Troubleshooting



Neato app robot status	What it means	What to do
<p>“Robot Offline” message in the Neato app</p>	<p>The robot is disconnected from its Wi-Fi connection.</p>	<p>The Neato robot may occasionally go offline if the signal strength of the Wi-Fi connection is weak or intermittent. This is usually a temporary situation, and typically, the robot will go back online on its own once it re-establishes a connection. In cases where the robot does not come back online within a few minutes, check the following:</p> <ol style="list-style-type: none"> 1) Make sure the Wi-Fi network to which your robot is connected is working and that the signal strength is strong in any areas where the robot is cleaning. 2) Reset your Neato robot by taking it off of its charge base, press and hold the Start Button for 15 seconds to turn it off, and then press Start Button one more time to turn it on. Wait a few minutes and then check the Neato app to see if it now says READY TO CLEAN. 3) If the steps above do not fix the issue: Delete your robot from the Neato app, and go through the steps to connect your robot again. It should then say READY TO CLEAN.
<p>“It seems you are not connected to the internet” message in the Neato app</p>	<p>Your phone/ tablet with the Neato app is not connected to Wi-Fi or cellular service.</p>	<p>Make sure your phone/tablet is connected to Wi-Fi or cellular service so that the Neato app can communicate with your robot.</p>
<p>“Duplicate Floor Plan”</p>	<p>You are attempting to create a second or third</p>	<p>The robotic vacuum determines what floor plan it is in based on where it</p>



<p>message while creating multiple floor plans in the Neato App.</p>	<p>floor plan and it looks too similar to an existing floor plan that has been saved.</p>	<p>starts. Try moving the charge base to another location in the room or another room and start the new floor plan process again. It helps if there is a side wall or large furniture within 10 feet of the charge base to distinguish it from other rooms.</p>
<p>"Area too empty" message when creating a floor plan.</p>	<p>This means there is no side wall or large furniture near the charge base making it difficult for the robot to distinguish this area from others in the home.</p>	<p>Place the charge base in an area where there is a side wall or other large furniture within a 10 foot radius of the charging station.</p>

NOTE Context-Sensitive help is also provided in the Neato app to help you troubleshoot items.

Warning

This content is compiled from multiple sources and is provided for reference purposes only. It may not be complete or fully applicable to all situations. If you are unable to resolve your issue, please contact the product manufacturer or an authorized service provider for official support.

