

USER'S MANUAL for Treadmill

BEFORE YOU BEGIN

Thank you for selecting the revolutionary NORDICTRACK® COMMERCIAL 1750 treadmill. The COMMERCIAL 1750 treadmill offers an impressive selection of features designed to make your workouts at home more effective and enjoyable. And when you're not exercising, the unique treadmill can be folded up, requiring less than half the floor space of other treadmills.

For your benefit, read this manual carefully before using the treadmill. If you have questions after reading this manual, please see the front cover of this manual. To help us assist you, please note the product model number and serial number before contacting us. The model number and the location of the serial number decal are shown on the front cover of this manual.

Before reading further, please review the drawing below and familiarize yourself with the labeled parts.

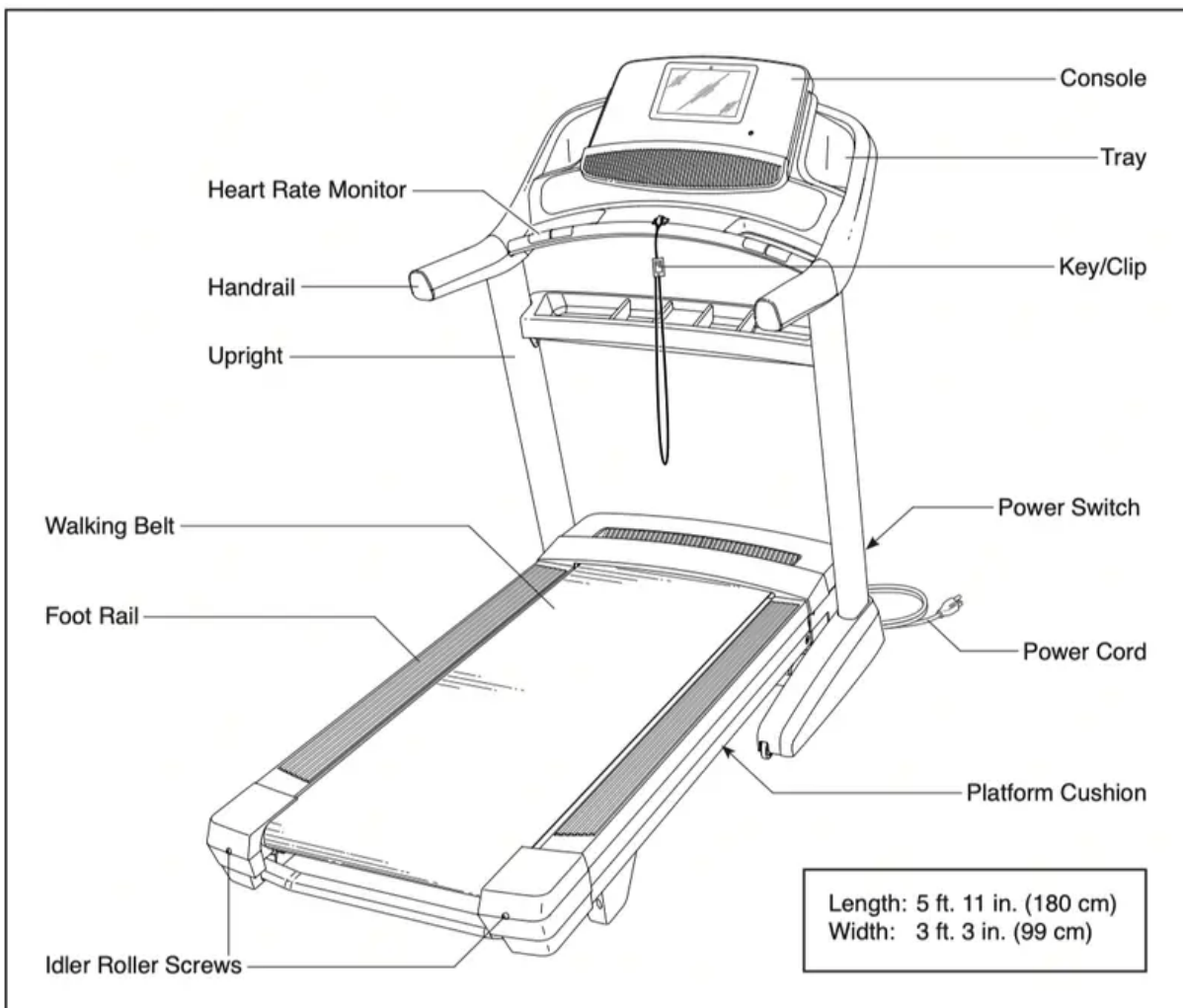

PART IDENTIFICATION CHART

Use the drawings below to identify small parts used for assembly. The number in parentheses below each drawing is the key number of the part, from the PART LIST near the end of this manual. The number following the key number is the quantity used for assembly. **Note:** If a part is not in the hardware kit, check to see whether it is preattached. Extra parts may be included.

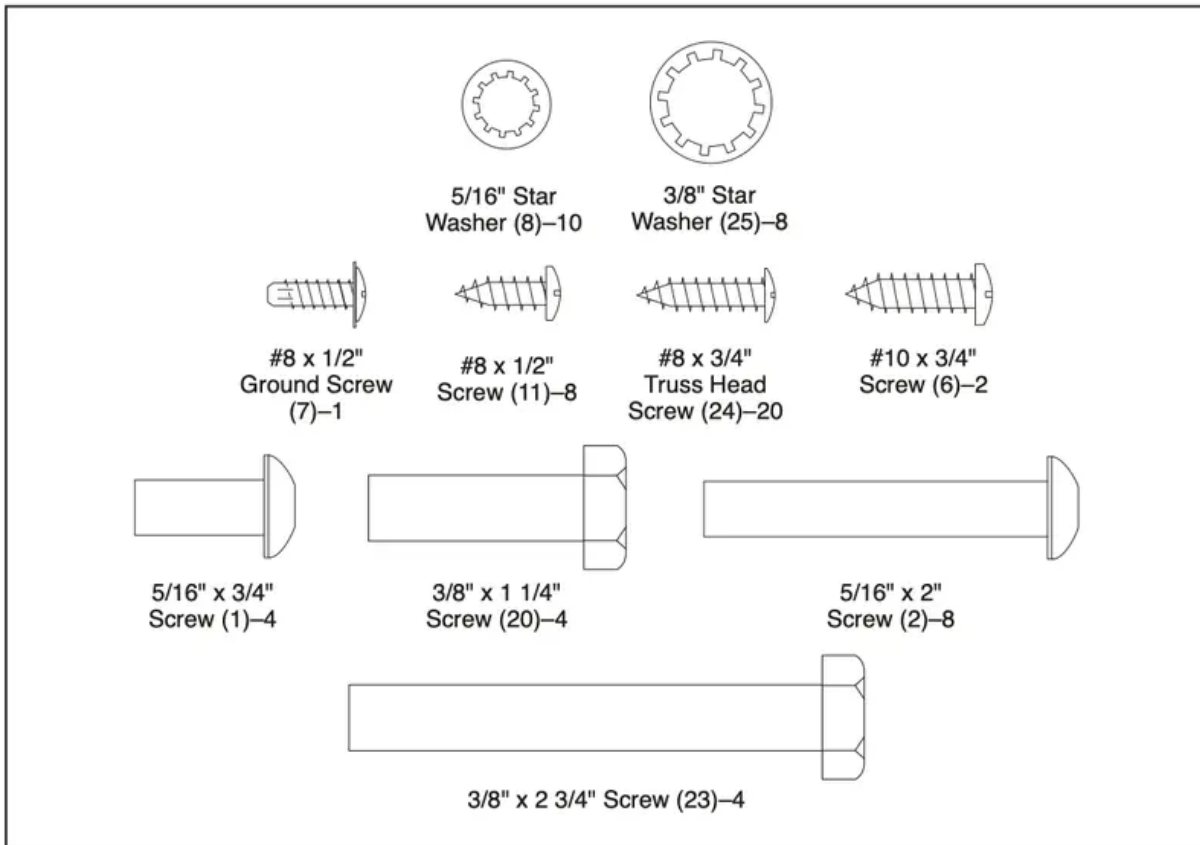

ASSEMBLY

- Assembly requires two persons.
- Place all parts in a cleared area and remove the packing materials. Do not dispose of the packing materials until you finish all assembly steps.
- After shipping, there may be an oily substance on the exterior of the treadmill. This is normal. If there is an oily substance on the treadmill, wipe it off with a soft cloth and a mild, non-abrasive cleaner.
- To identify small parts, see page 7.
- Left parts are marked "L" or "Left" and right parts are marked "R" or "Right."
- Assembly requires the following tools:

the included hex key

one adjustable wrench

one Phillips screwdriver



To avoid damaging parts, do not use power tools.

1. Go to my.nordictrack.com on your computer and register your product.

- documents your ownership
- activates your warranty
- ensures priority customer support if assistance is ever needed

Note: If you do not have internet access, call Customer Care (see the front cover of this manual) and register your product.

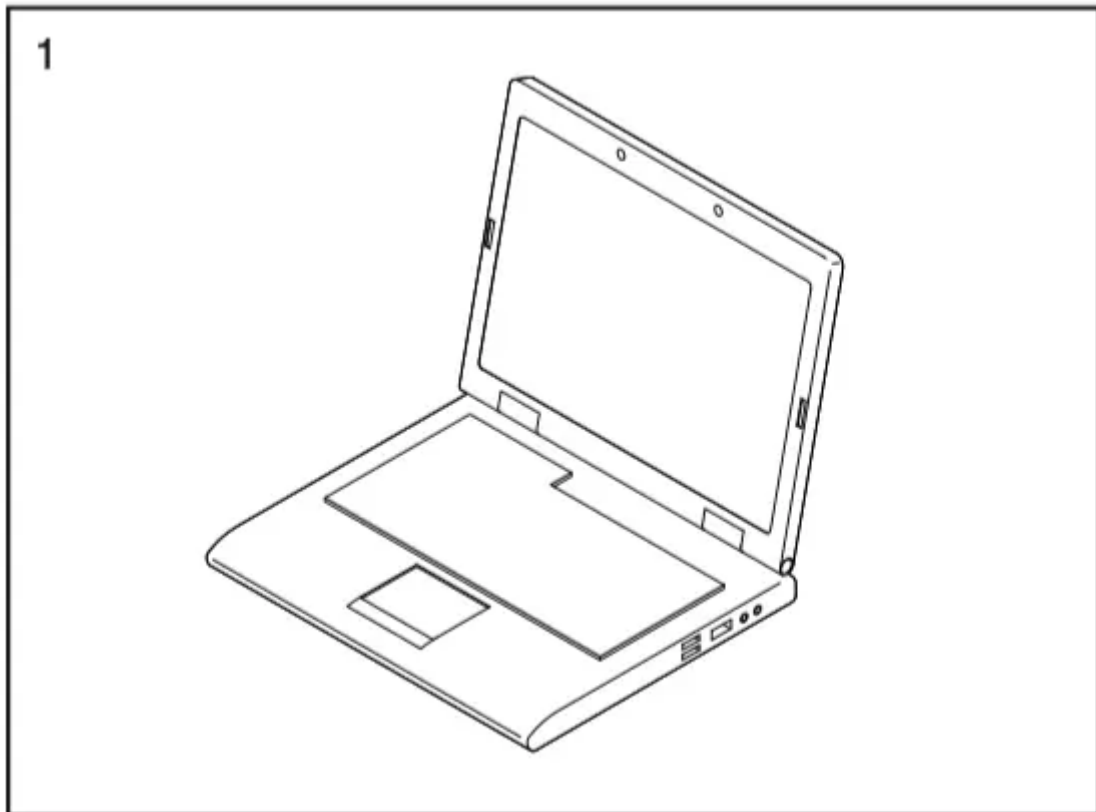

2. Make sure that the power cord is unplugged.

Remove the tie securing the Upright Wire (83) to the front of the Base (93).

Next, identify the Right Upright (84). Have a second person hold the Right Upright near the Base (93).

See the inset drawing. Tie the wire tie (A) in the Right Upright (84) securely around the end of the Upright Wire (83). Then, insert the Upright Wire into the lower end of the Right Upright as you pull the other end of the wire tie through the Right Upright.

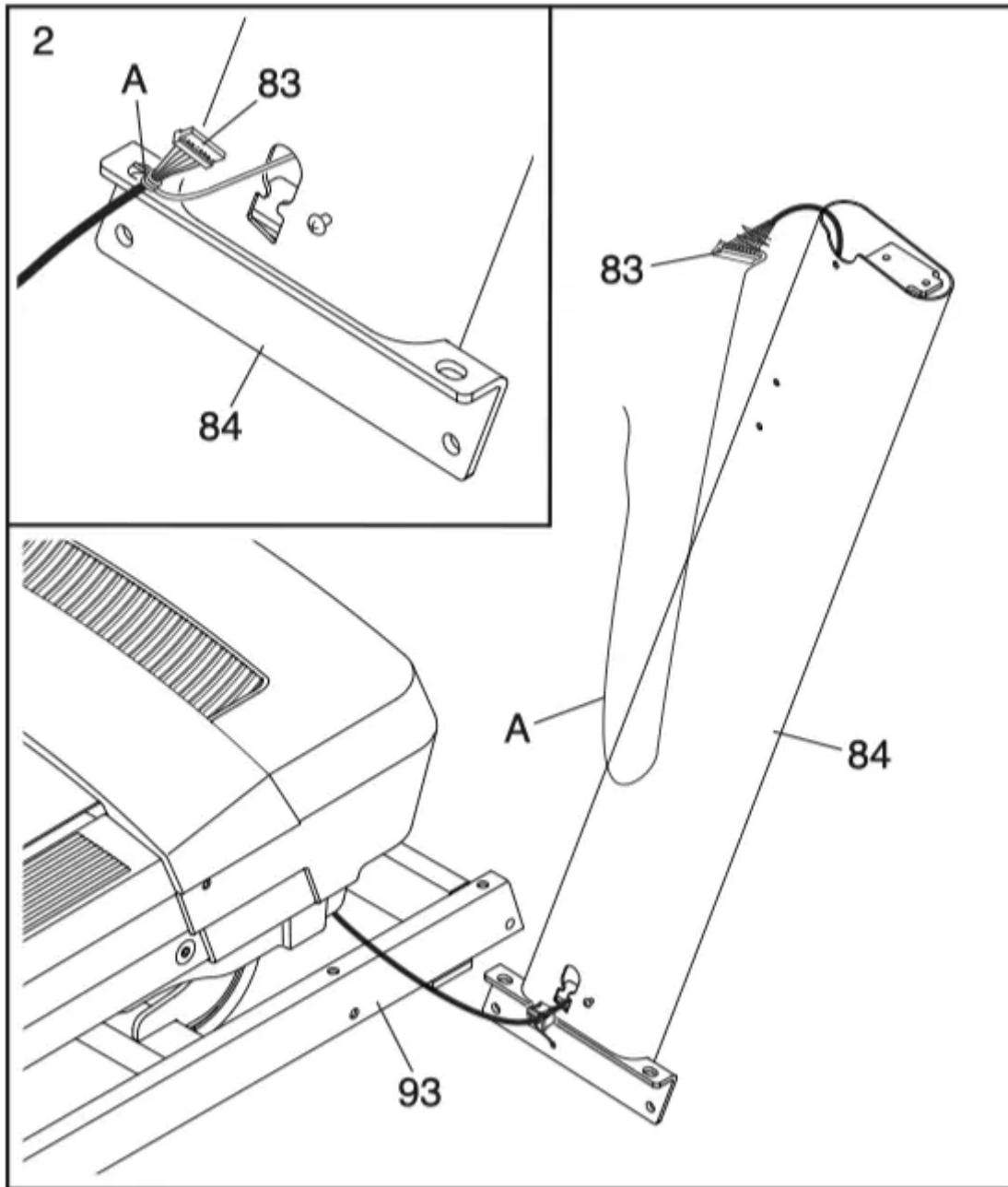

3. Lay the Right Upright (84) near the Base (93).

Press the Upright Grommet (86) into the square hole (B) in the Right Upright. Make sure not to pinch the ground wire (C).

If there is a screw (D) preattached to the Right Upright (84), remove and discard it.

Then, attach the ground wire (C) to the Right Upright (84) with a #8 x 1/2" Ground Screw (7).

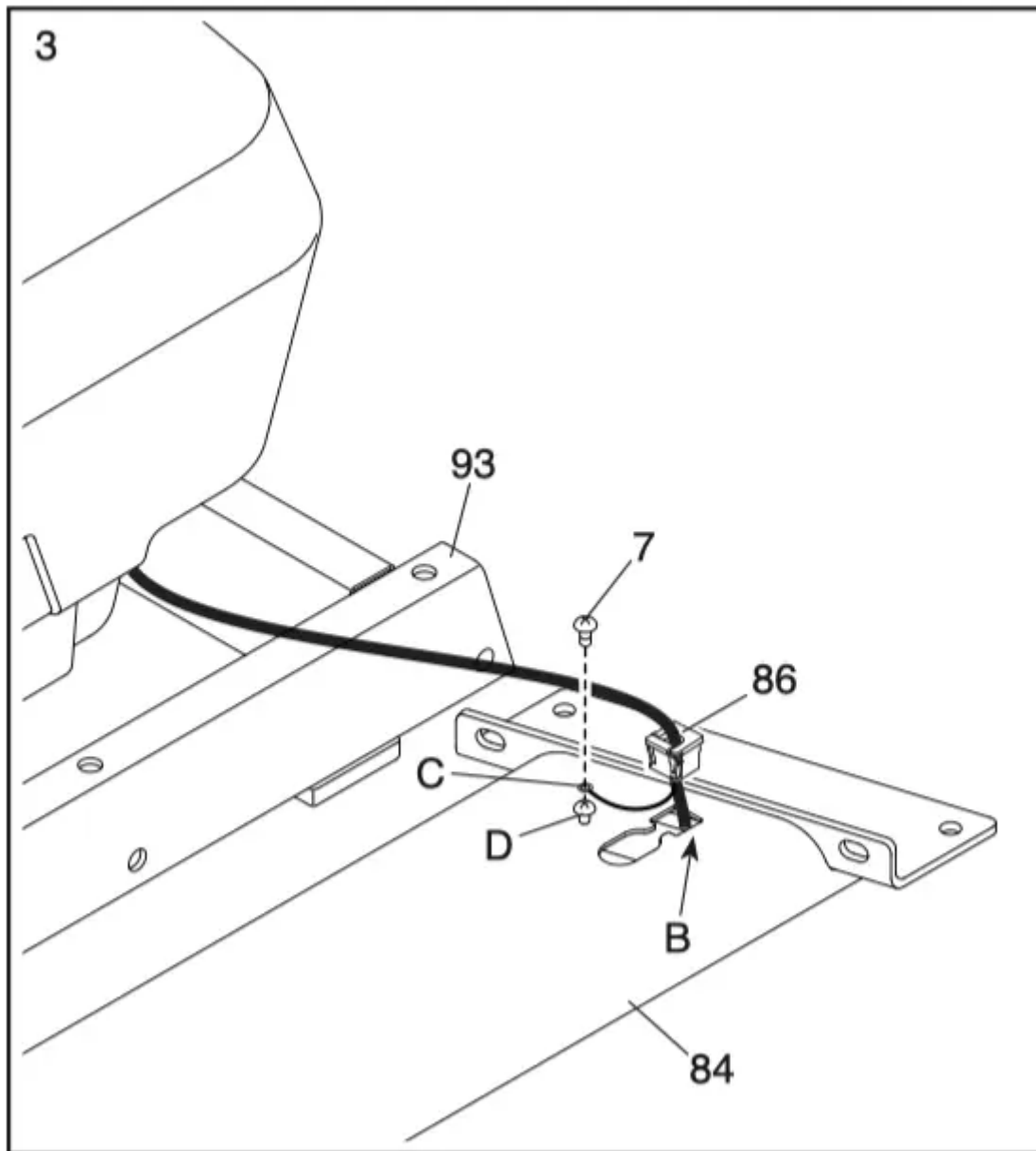

4. Hold the Right Upright (84) against the Base (93). Make sure not to pinch the Upright Wire (83). Attach the Right Upright (84) with two $\frac{3}{8}$ " x $2\frac{3}{4}$ " Screws (23), two $\frac{3}{8}$ " x $1\frac{1}{4}$ " Screws (20), and four $\frac{3}{8}$ " Star Washers (25) as shown; do not fully tighten the Screws yet. Attach the Left Upright (not shown) in the same way. Note: There are no wires on the left side.

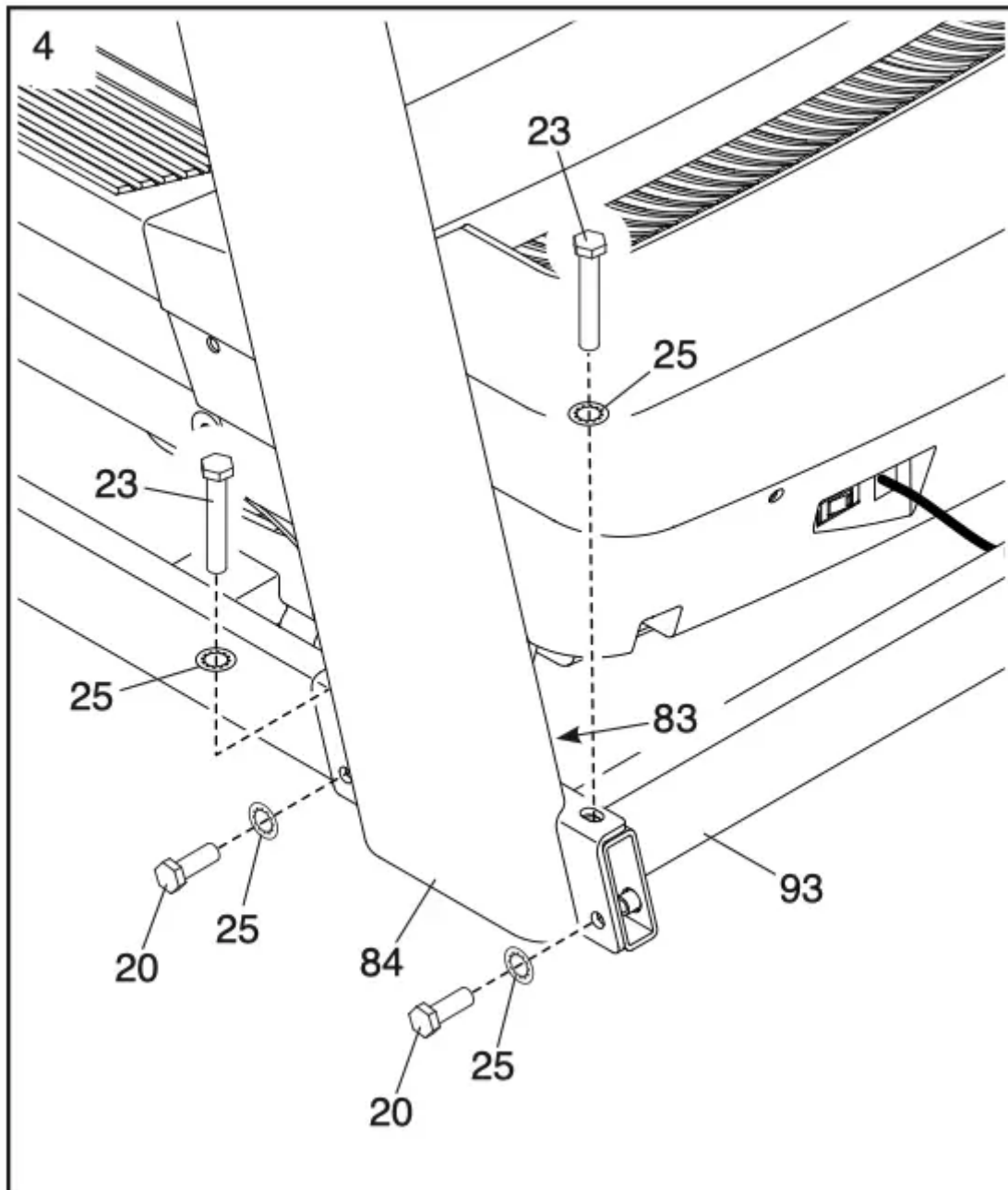

5. Identify the Left and Right Base Covers (89, 90).

Slide the Left Base Cover (89) onto the Left Upright (91), and slide the Right Base Cover (90) onto the Right Upright (84). Press the Base Covers downward, but do not snap the Base Covers into place yet.

If there is a film (E) covering the decal on each Upright (84, 91), carefully remove the film.



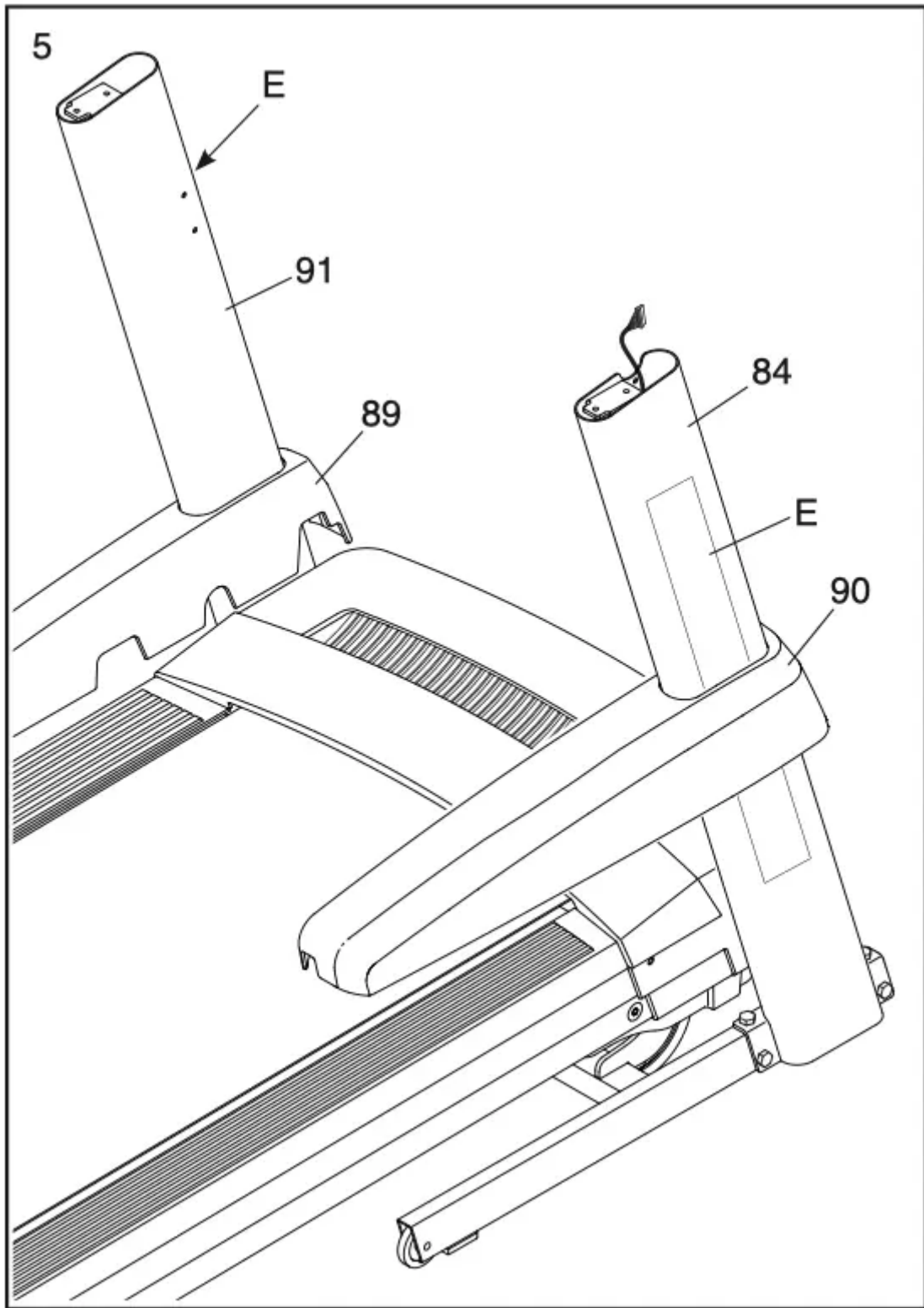

6. Carefully slide the Upright Crossbar (76) between the Right and Left Uprights (84, 91). Attach the Upright Crossbar with four 5/16" x 3/4" Screws (1); start all four Screws, and then tighten them.



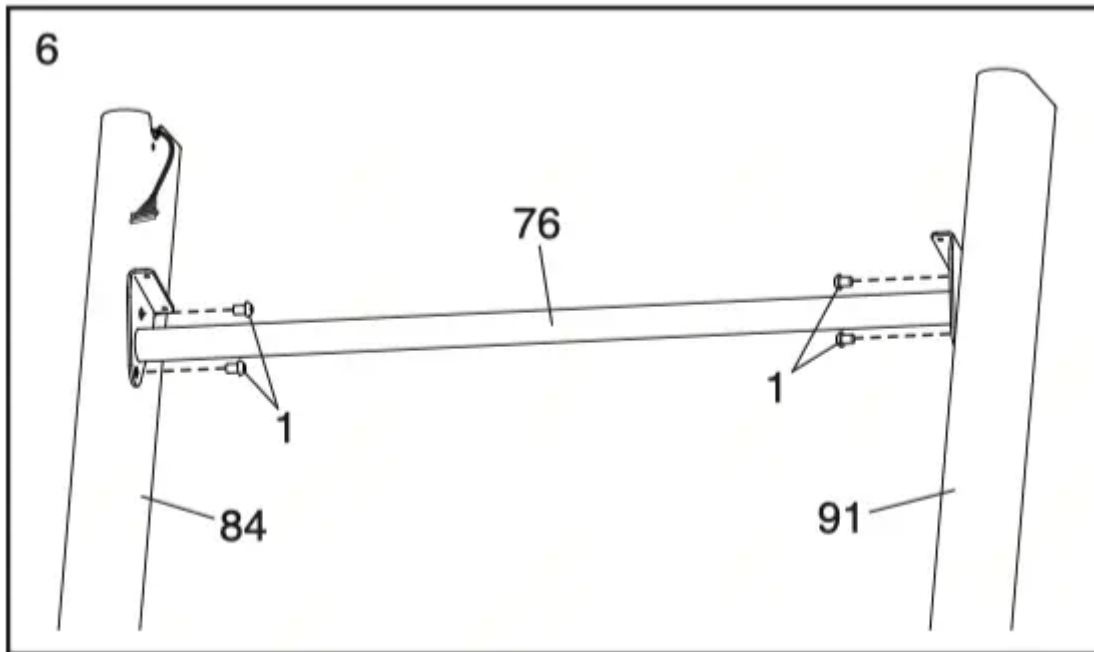

7. Attach the Tray (79) to the Upright Crossbar (76) with four #8 x 3/4" Truss Head Screws (24); start all four Truss Head Screws, and then tighten them.

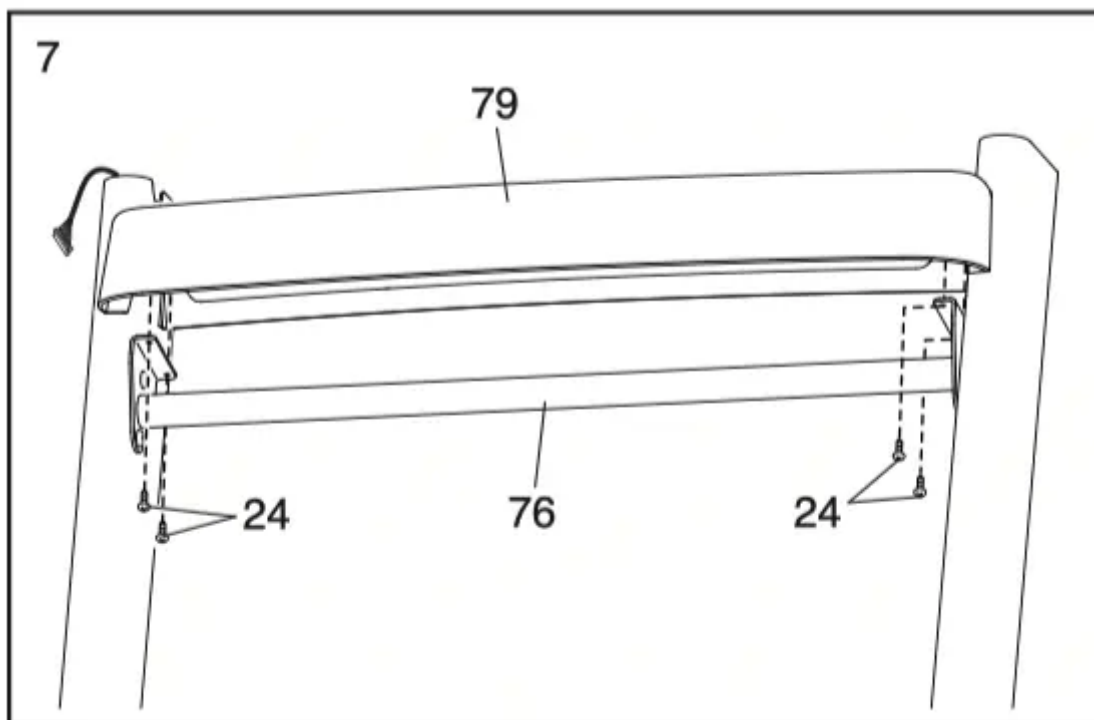

8. Attach the two Handrails (74) to the Right and Left Uprights (84, 91) with two 5/16" x 2" Screws (2) and two 5/16" Star Washers (8); do not fully tighten the Screws yet. Be careful not to pinch the Upright Wire (83) on the right side. Position the Upright Wire in the notch (F) as shown.

Then, remove and discard the two indicated screws (G).

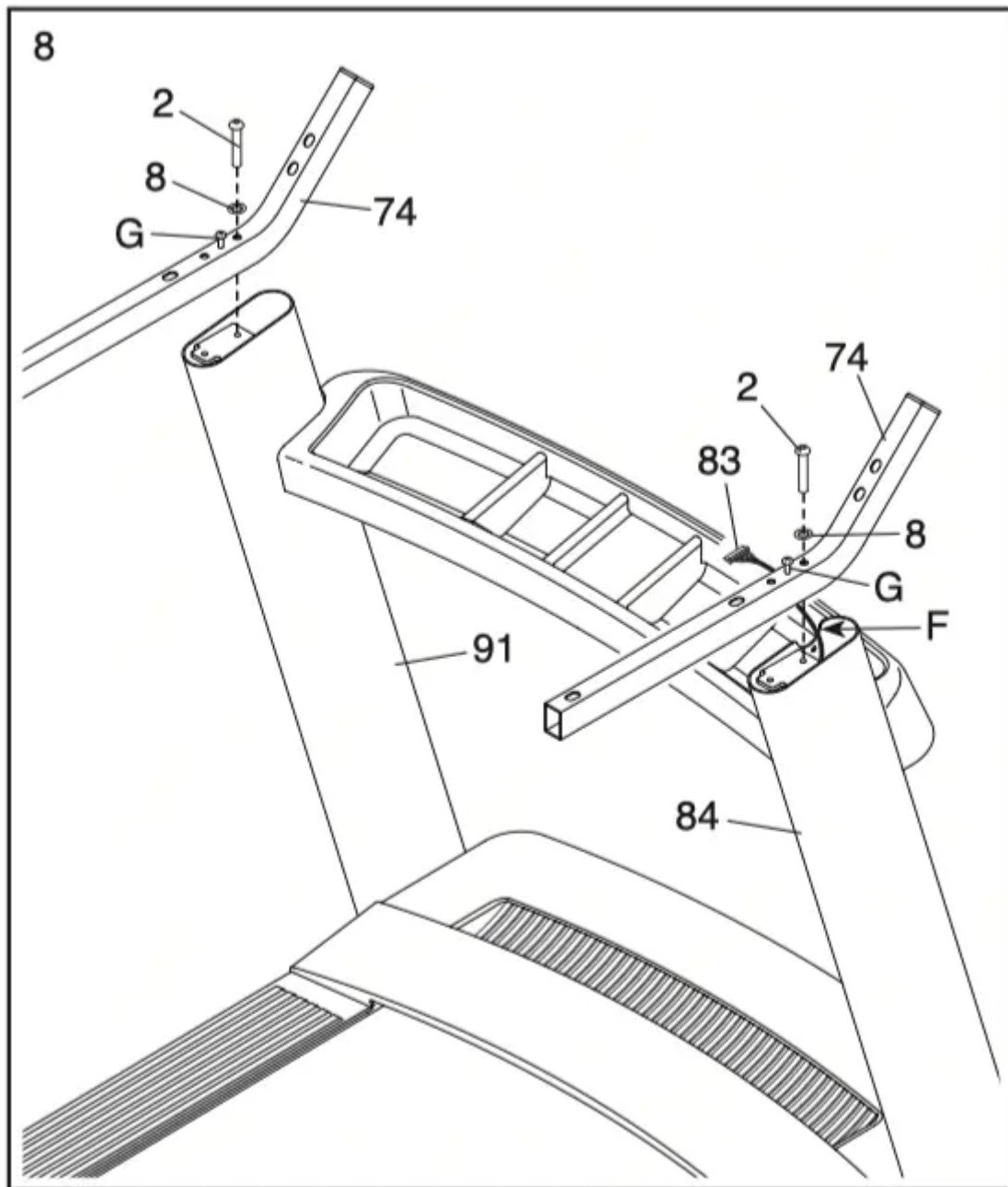

9. Set the console assembly (H) face down on a soft surface to avoid scratching the console assembly.

Remove and discard the four indicated screws (I). Then, remove the Pulse Crossbar (80).

Next, identify the Left and Right Trays (94, 101). Attach the Trays to the console assembly (H) with eight #8 x 1/2" Screws (11). Do not overtighten the Screws.

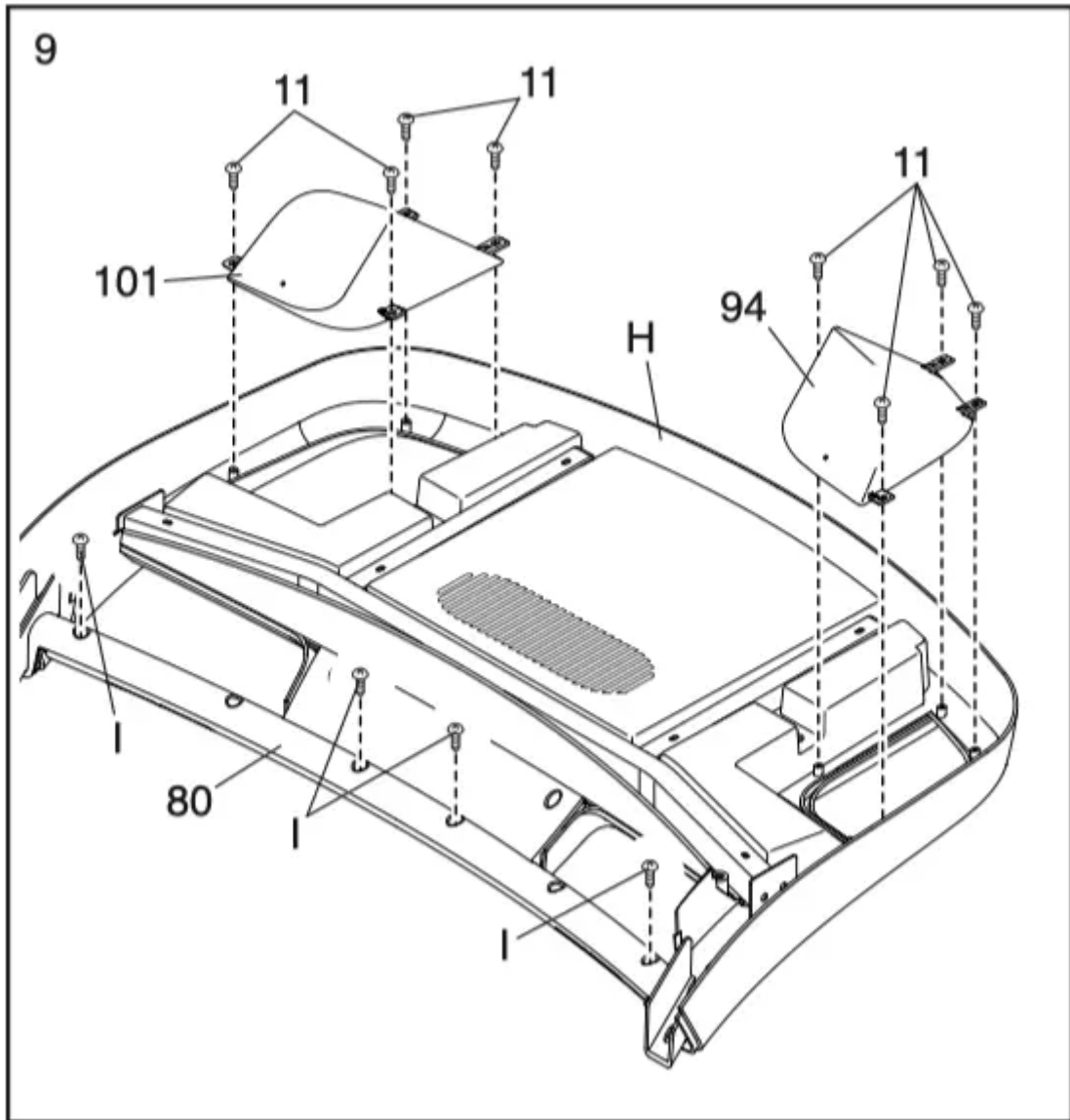

10. **IMPORTANT:** To avoid damaging the Pulse Crossbar (80), do not use power tools, and do not overtighten the #10 x 3/4" Screws (6) or the 5/16" x 2" Screws (2).

Orient the Pulse Crossbar (80) as shown. Attach the Pulse Crossbar with two 5/16" x 2" Screws (2), two 5/16" Star Washers (8), and two #10 x 3/4" Screws (6); start all four Screws, and then tighten them.

Then, tighten the other two 5/16" x 2" Screws (2).

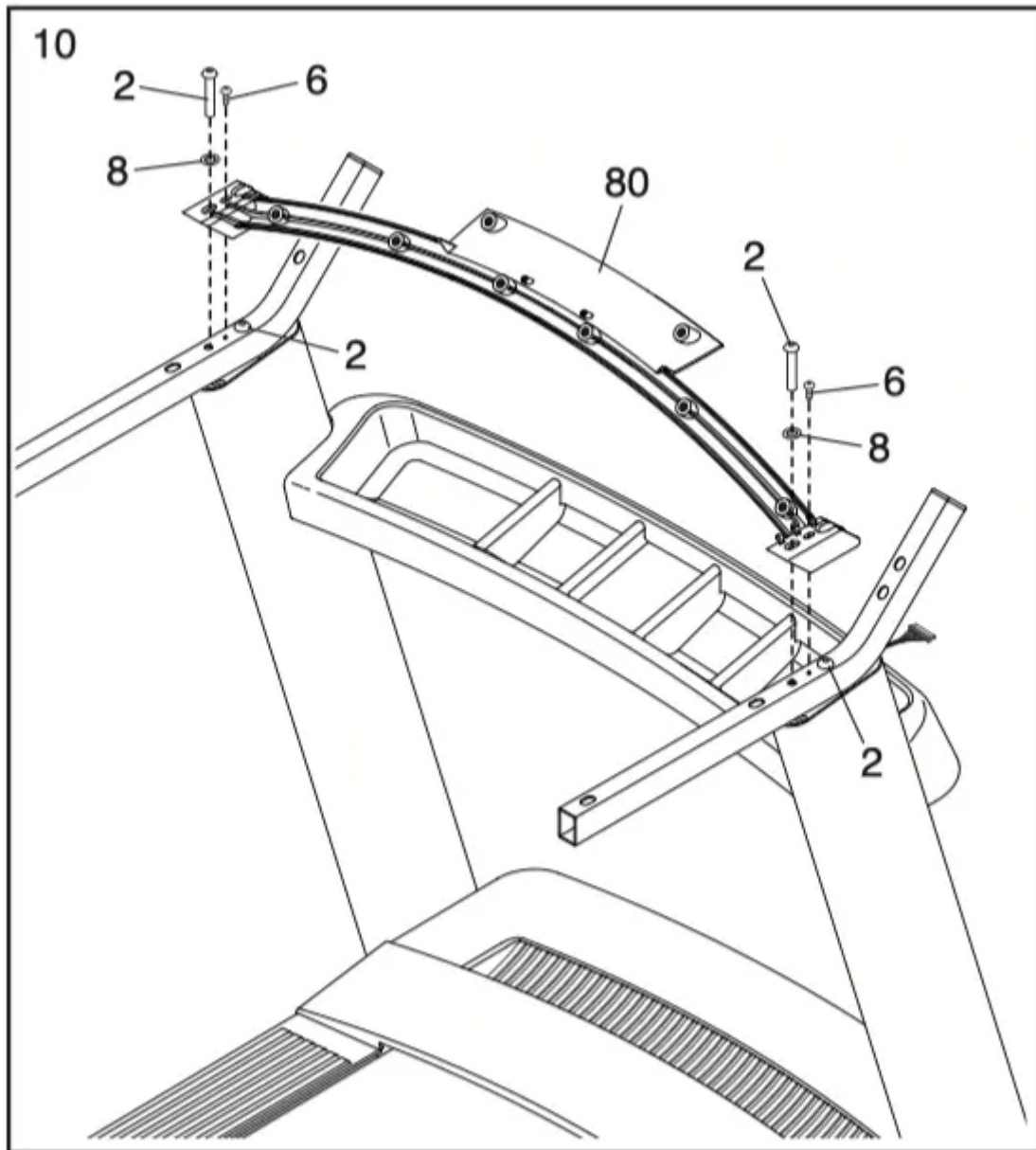

11. With the help of a second person, hold the console assembly (H) near the Handrails (74).

See the inset drawing. Connect the Upright Wire (83) to the console wire (J). The connectors should slide together easily and snap into place. If they do not, turn one connector and try again. IF YOU DO NOT CONNECT THE CONNECTORS PROPERLY, THE CONSOLE MAY BECOME DAMAGED WHEN YOU TURN ON THE POWER.

Then, remove any wire ties (K) from the Upright Wire (83).

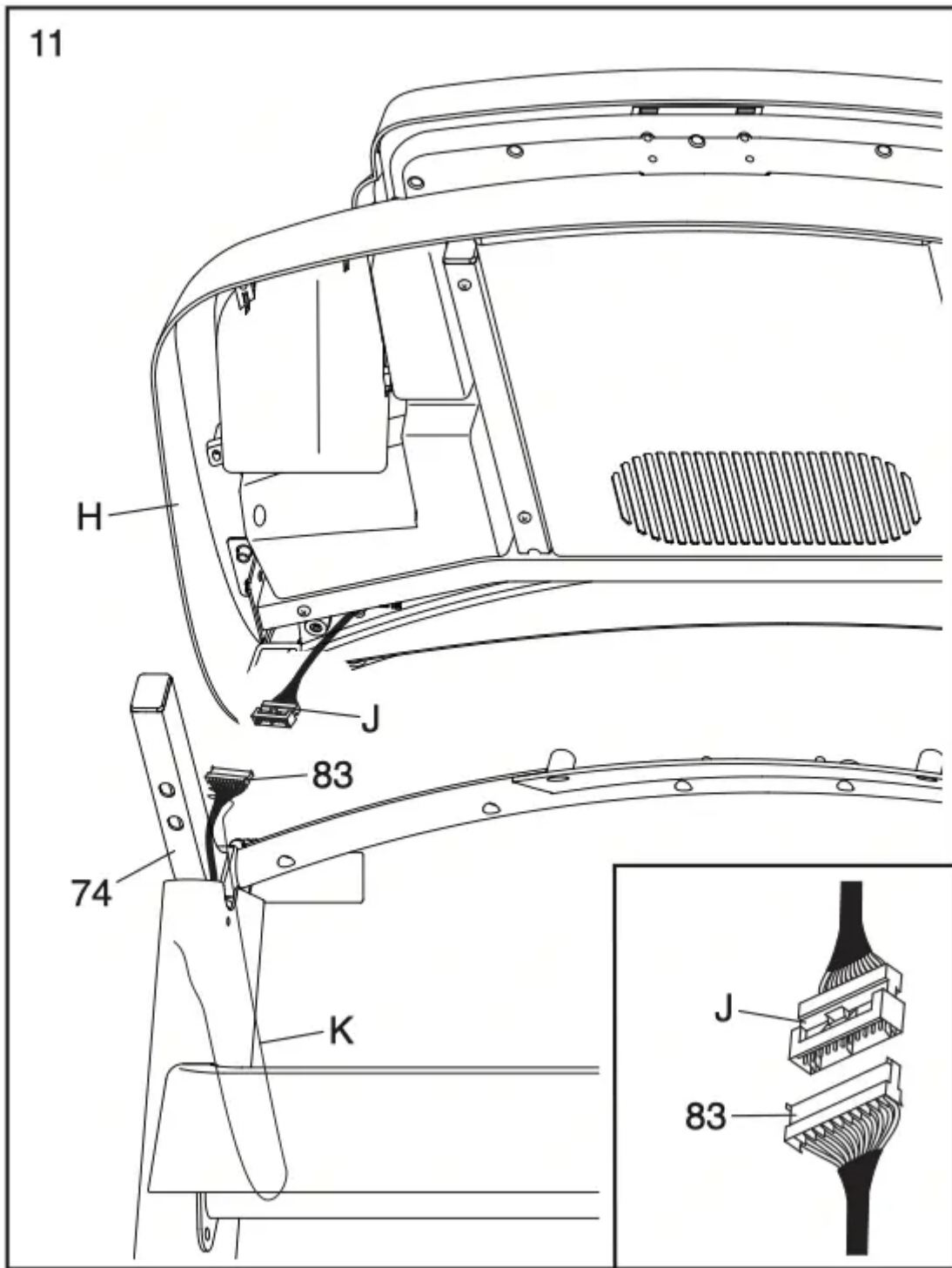

12. Attach the console assembly (H) to the Handrails (74) with four 5/16" x 2" Screws (2) and four 5/16" Star Washers (8); start all four Screws, and then tighten them. Be careful not to pinch the wires (J).

Insert the wires (J) into the top of the Right Upright (84).

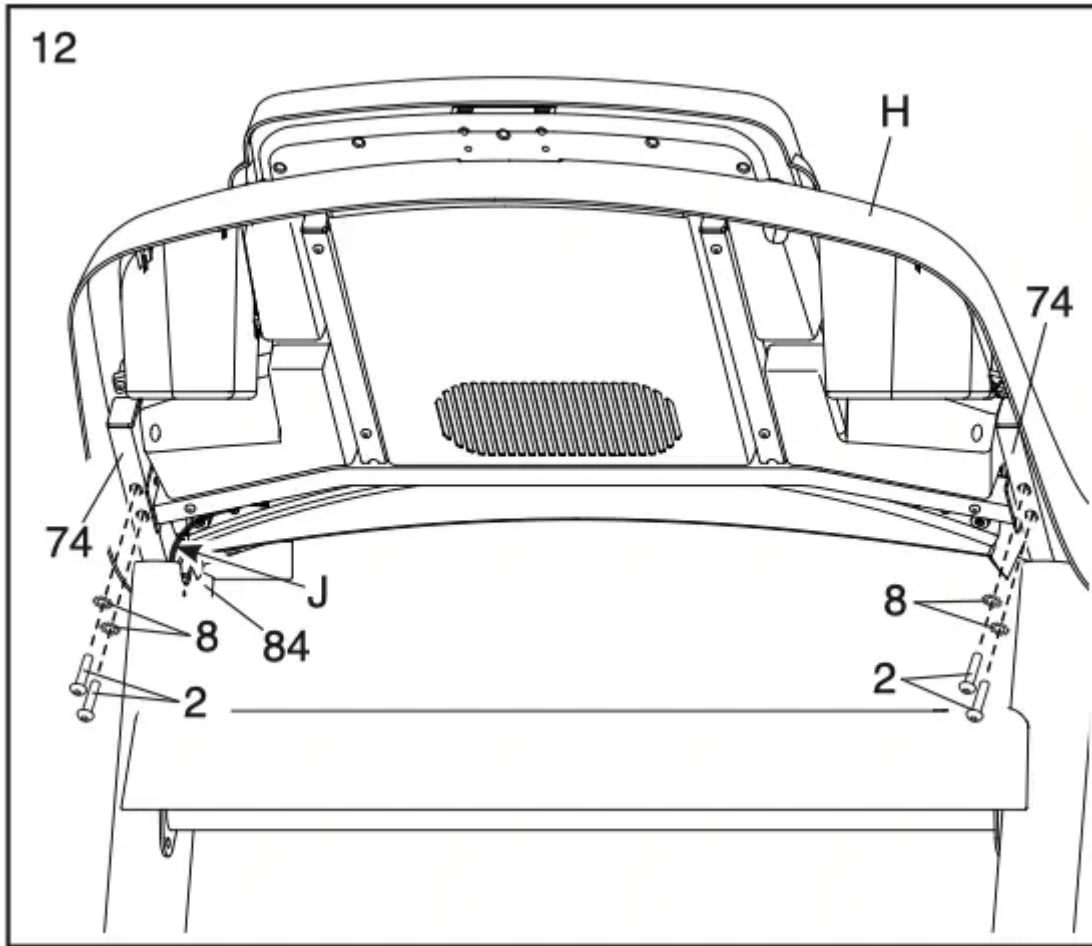

13. Start eight #8 x 3/4" Truss Head Screws (24) into the Pulse Crossbar (80), and then tighten them; do not overtighten the Truss Head Screws.



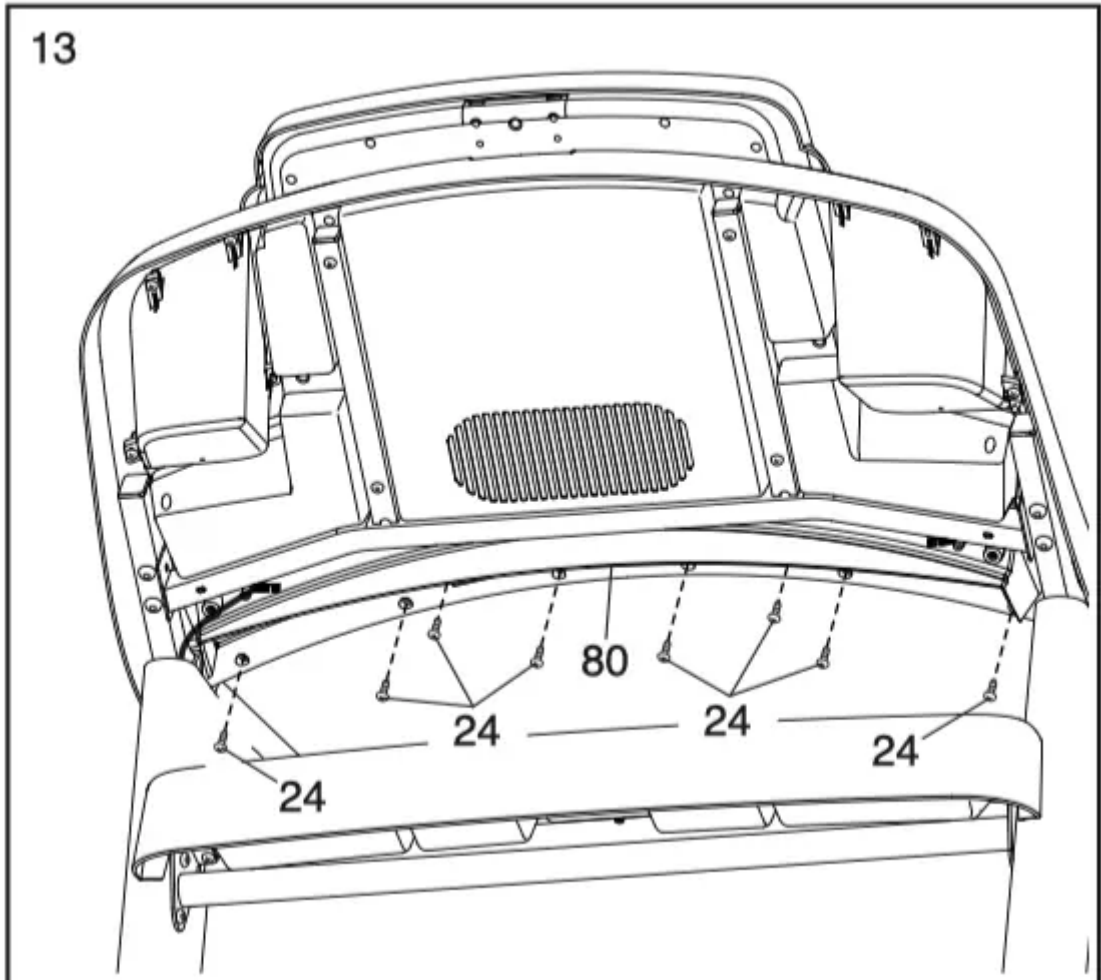

14. Set the Left Handrail Top Cover (73) on the left Handrail (74). Start four #8 x 3/4" Truss Head Screws (24) into the Left Handrail Bottom Cover (75), the left Handrail, and the Left Handrail Top Cover. Next, slide the Left Handrail Top and Bottom Covers forward against the console assembly (H) as shown. Tighten the two middle Truss Head Screws first. Then, tighten the other two Truss Head Screws

Attach the Right Handrail Top and Bottom Covers (81, 82) to the right Handrail (74) as described above.

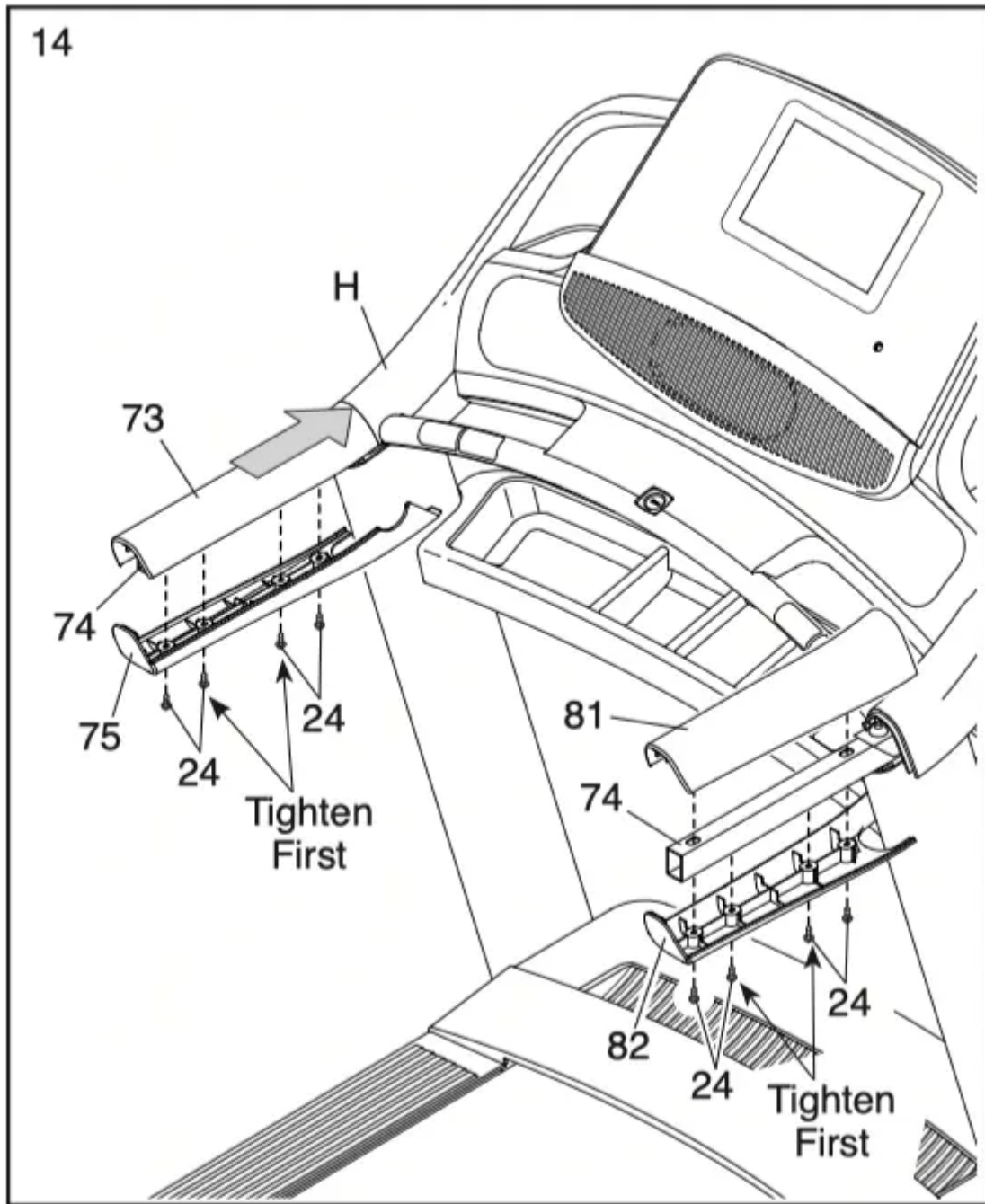

15. Raise the Frame (52) to the upright position.

Have a second person hold the Frame until step 17 is completed.

Remove the two 5/16" x 1 1/4" Screws (16) from the Latch Crossbar (109).

Orient the Latch Crossbar (109) as shown. Make sure that the "This side toward belt" sticker (L) is facing the treadmill.

Attach the Latch Crossbar (109) to the brackets (M) on the Frame (52) with the two 5/16" x 1 1/4" Screws (16) and two 5/16" Star Washers (8).

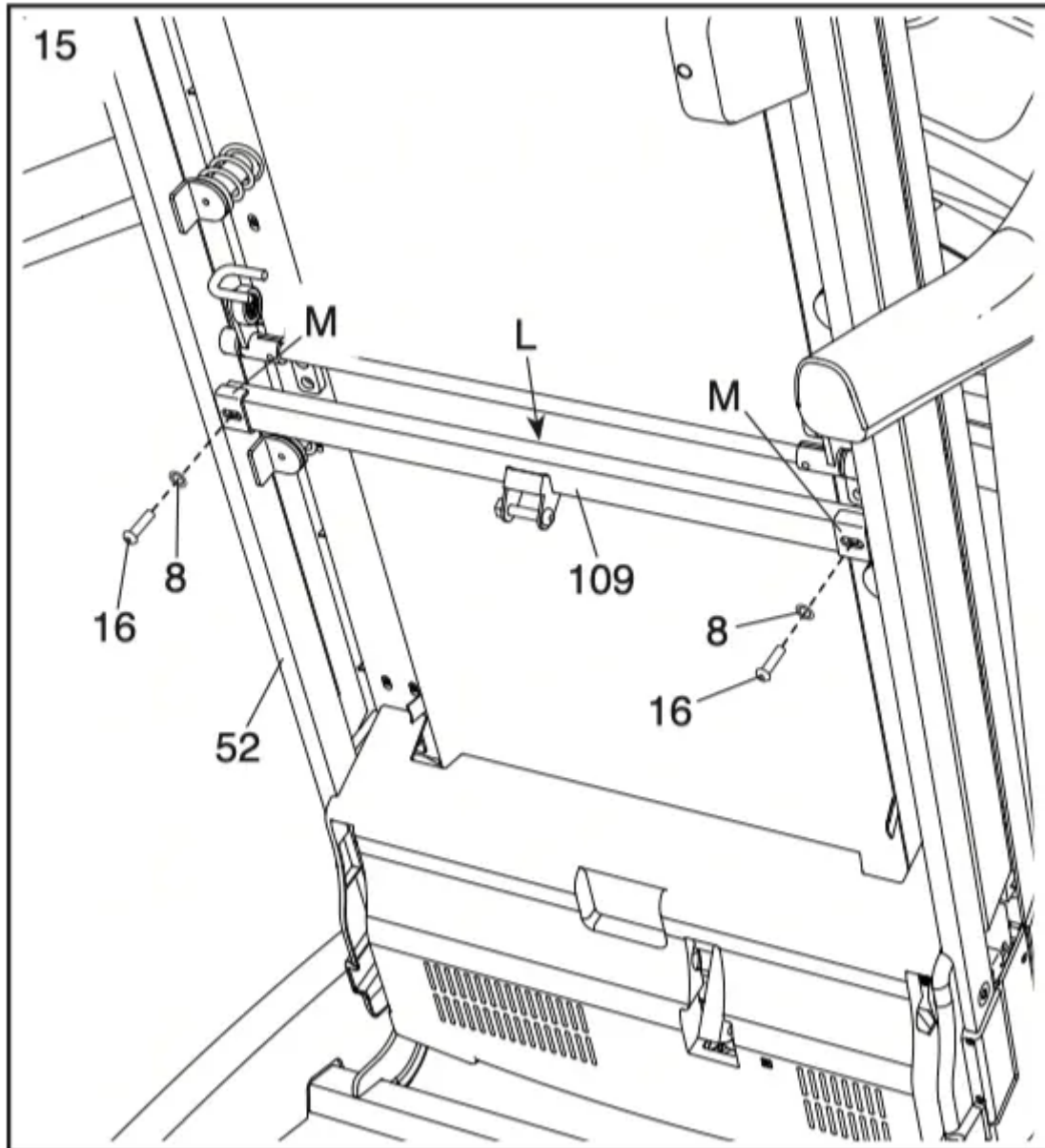

16. Remove the 5/16" Nut (9) and the 5/16" x 1 3/4" Bolt (3) from the bracket on the Base (93).

Next, orient the Storage Latch (56) as shown.

Attach the lower end of the Storage Latch (56) to the bracket on the Base (93) with the 5/16" x 1 3/4" Bolt (3) and the 5/16" Nut (9).

Then, raise the Storage Latch (56) to a vertical position and remove the tie (N).

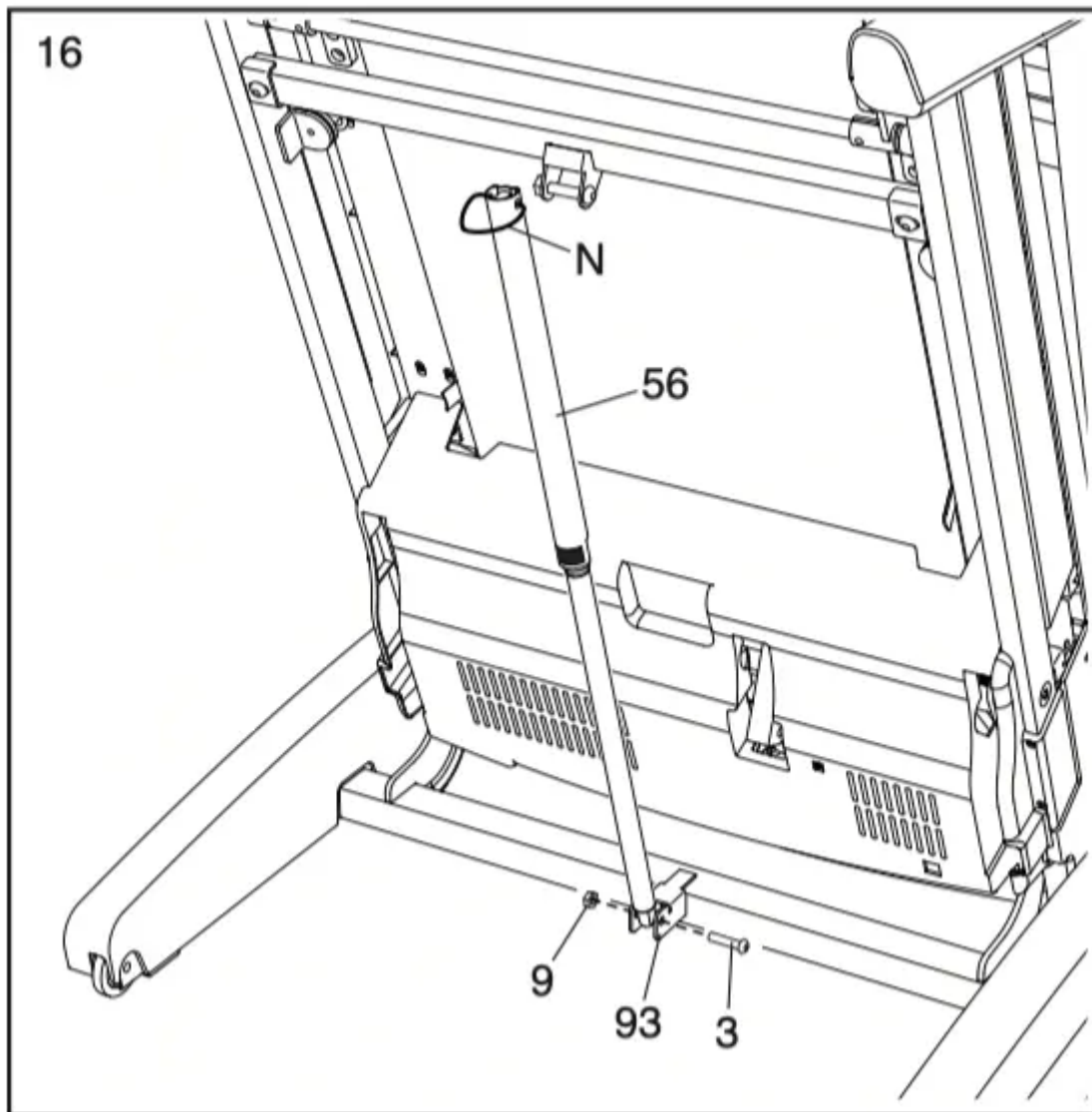

17. Remove the 5/16" Nut (9) and the 5/16" x 2 1/4" Bolt (4) from the bracket on the Frame (52).

Align the upper end of the Storage Latch (56) with the bracket on the Frame (52), and insert a 5/16" x 2 1/4" Bolt (4) through the bracket and the Storage Latch. This will push a spacer (O) out of the Storage Latch; discard the spacer.

Next, tighten the 5/16" Nut (9) onto the 5/16" x 2 1/4" Bolt (4). Do not overtighten the Nut; the Storage Latch (56) must be able to pivot.

Then, lower the Frame (52) (see HOW TO LOWER THE TREADMILL FOR USE on page 29).

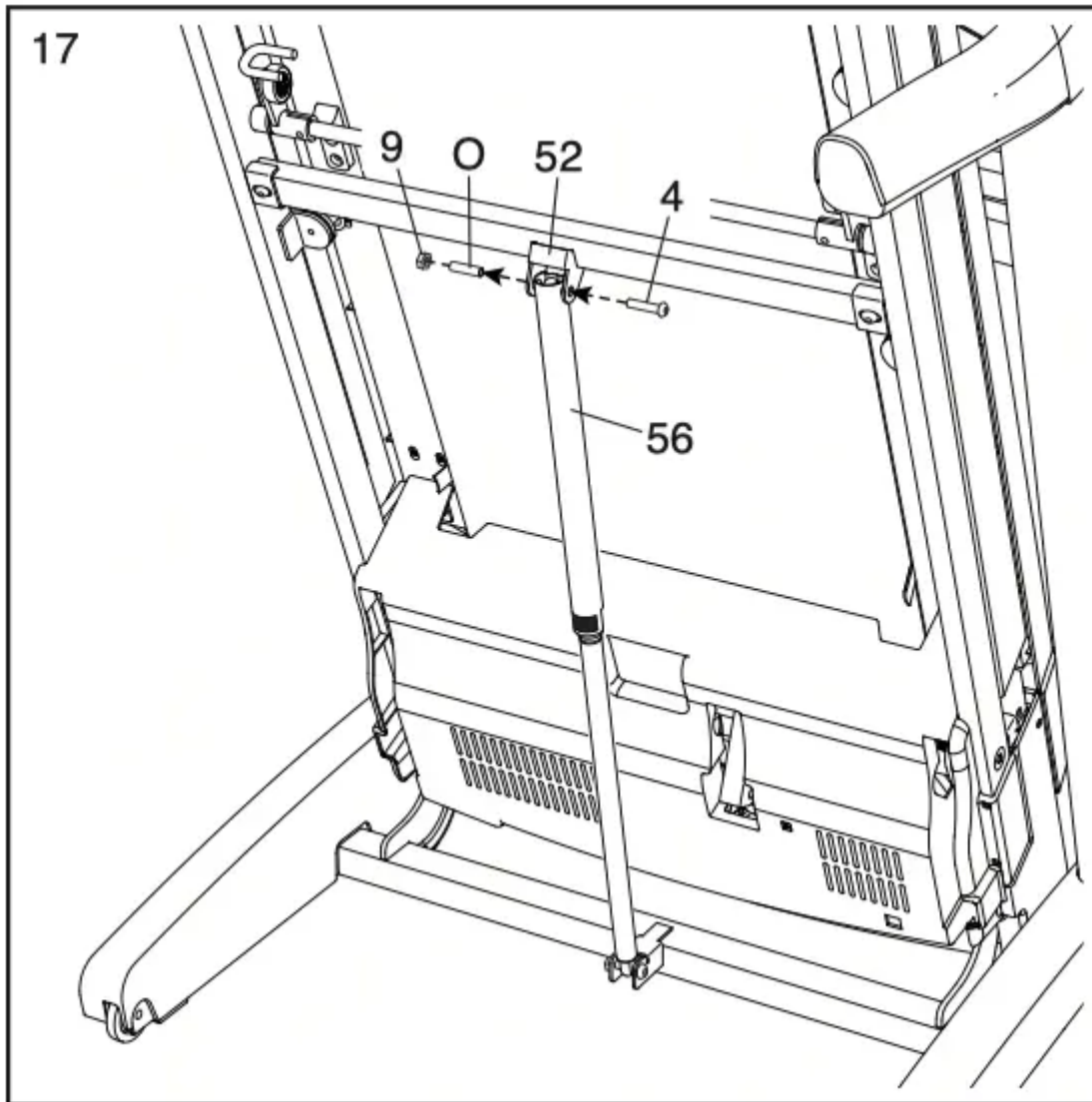

18. Firmly tighten the four 3/8" x 2 3/4" Screws (23) and the four 3/8" x 1 1/4" Screws (20).
Then, slide the Left and Right Base Covers (89, 90) downward until they snap into place.



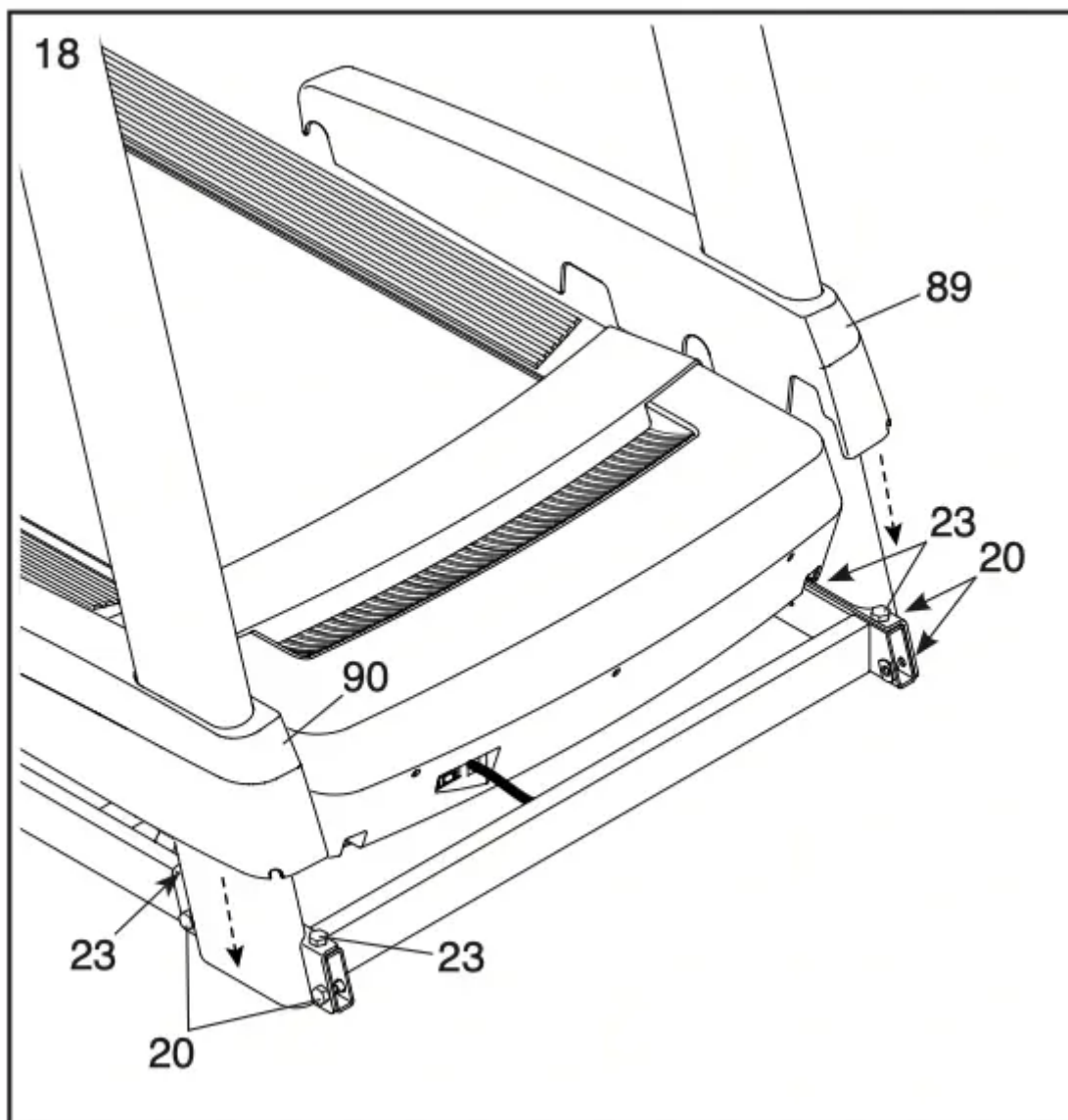

19. Make sure that all parts are properly tightened before you use the treadmill. If there are sheets of plastic on the treadmill decals, remove the plastic. To protect the floor or carpet, place a mat under the treadmill. To avoid damage to the console, keep the treadmill out of direct sunlight. Keep the included hex keys in a secure place; one of the hex keys is used to adjust the walking belt (see pages 31 and 32). **Note:** Extra parts may be included.

HOW TO USE THE TREADMILL

HOW TO CONNECT THE POWER CORD

Use a Surge Suppressor

Your treadmill, like other electronic equipment, can be damaged by sudden voltage changes in your home's power. Voltage surges, spikes, and noise interference can result from weather conditions or from other appliances being turned on or off. To decrease the risk of damaging the

treadmill, always use a surge suppressor with the treadmill. To purchase a surge suppressor, see precaution 14 on page 3.

Use only a surge suppressor that is UL 1449 listed as a transient voltage surge suppressor (TVSS). The surge suppressor must have a UL suppressed voltage rating of 400 volts or less and a minimum surge dissipation of 450 joules. The surge suppressor must also be electrically rated for 120 volts AC and 15 amps. There must be a monitoring light on the surge suppressor to indicate whether it is functioning properly. Failure to use a properly functioning surge suppressor could result in damage to the control system of the treadmill and serious injury to users.

Plug in the Power Cord

The treadmill must be grounded. If it should malfunction or break down, grounding provides a path of least resistance for electric current to reduce the risk of electric shock. The treadmill power cord has a plug with a grounding pin (see drawing 1 on this page).

DANGER:

Improper connection of the power cord increases the risk of electric shock. Do not modify the plug—if it will not fit an outlet, have a proper outlet installed by a qualified electrician. If you are unsure whether the treadmill is properly grounded, contact a qualified electrician.

Plug the power cord into a surge suppressor, and plug the surge suppressor into an appropriate outlet that is properly installed and grounded in accordance with all local codes and ordinances. The outlet must be on a nominal 120-volt circuit capable of carrying 15 or more amps. To avoid overloading the circuit, do not plug other electrical devices, except for low-power devices such as cell phone chargers, into the surge suppressor or into an outlet on the same circuit. **IMPORTANT:** If the treadmill is connected to an AFCI-equipped outlet and your circuit breaker trips repeatedly when the treadmill is used, see the front cover of this manual to purchase an arc filter.

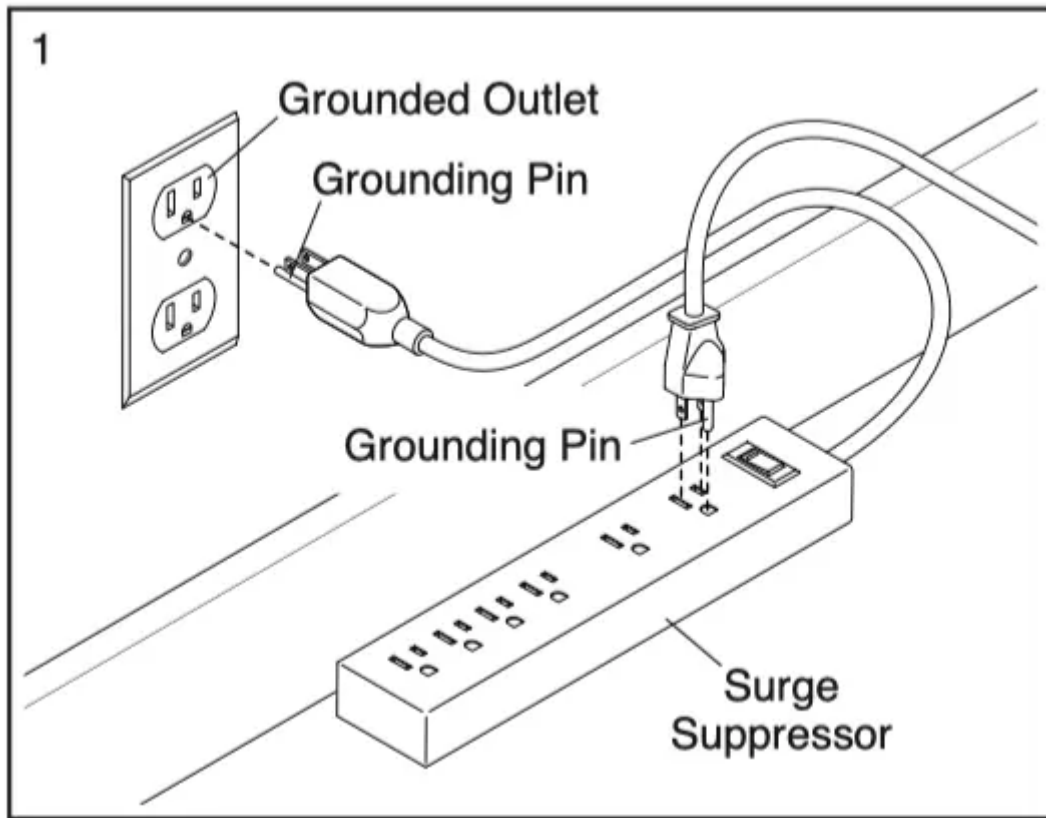

A temporary adapter may be used to connect the surge suppressor to a 2-pole receptacle if a properly grounded outlet is not available.

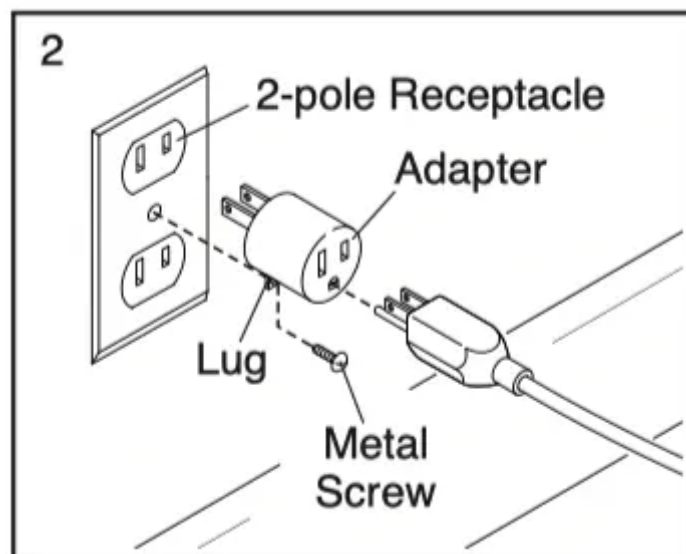

The lug or wire extending from the adapter must be connected with a metal screw to a permanent ground such as a properly grounded outlet box cover. Some 2-pole receptacle outlet box covers are not grounded. Before using an adapter, contact a qualified electrician to determine whether the outlet box cover is grounded. The temporary adapter should be used only until a properly grounded outlet can be installed by a qualified electrician.

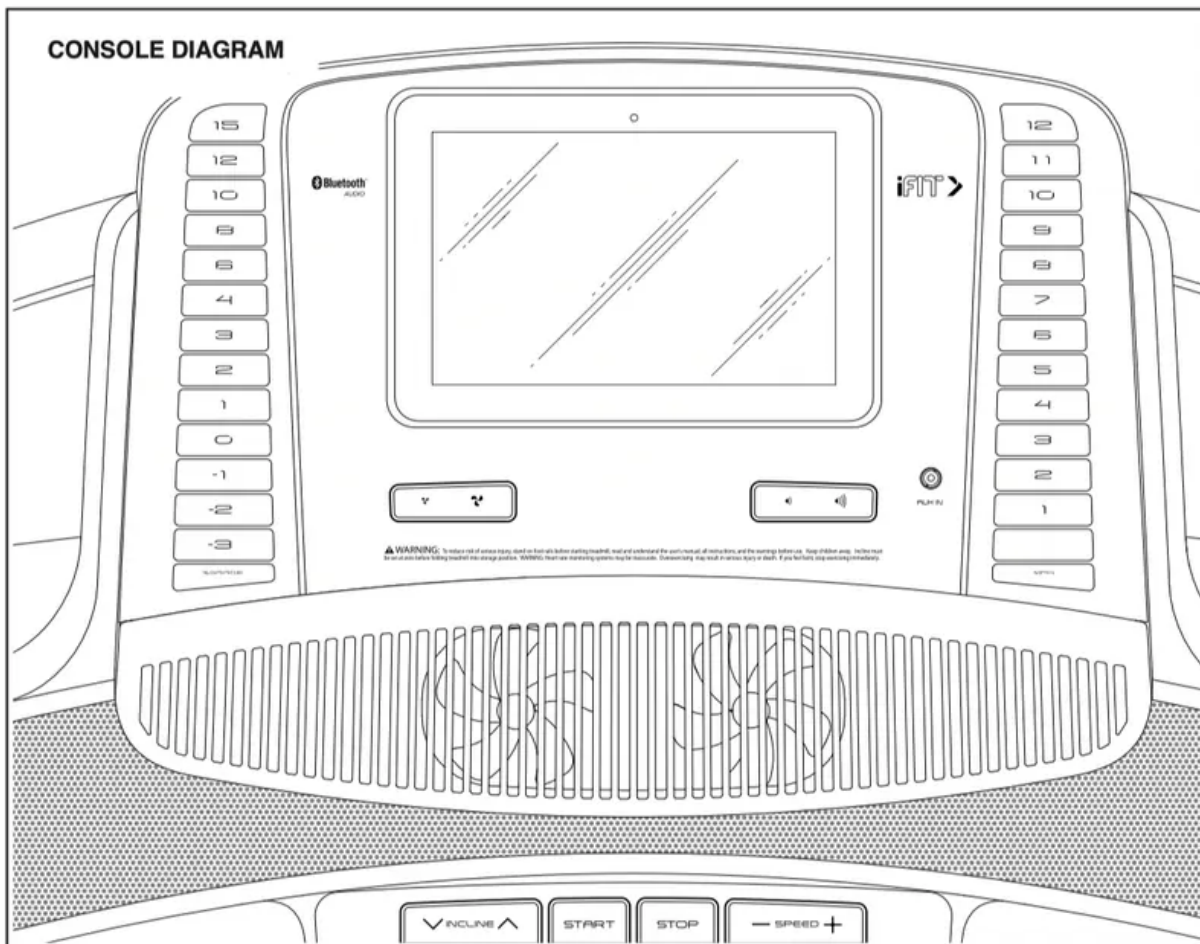

FEATURES OF THE CONSOLE

The advanced treadmill console offers a selection of features designed to make your workouts more effective and enjoyable.

The console features wireless technology that enables the console to connect to iFit. With iFit, you can access a large and varied workout library, create your own workouts, track your workout results, and access many other features.

When you use the manual mode, you can change the speed and incline of the treadmill with the touch of a button. As you exercise, the console will display instant exercise feedback. You can even measure your heart rate using the handgrip heart rate monitor or a compatible heart rate monitor. See page 27 for information about purchasing an optional chest heart rate monitor.

In addition, the console features a selection of workouts. Each workout automatically controls the speed and incline of the treadmill as it guides you through an effective exercise session.

You can even listen to your favorite workout music or audio books with the console's sound system while you exercise.

To turn on the power, see page 19. To learn how to use the touch screen, see page 19. To set up the console, see page 20.

HOW TO TURN ON THE POWER

IMPORTANT: If the treadmill has been exposed to cold temperatures, allow it to warm to room temperature before you turn on the power. If you do not do this, you may damage the console displays or other electrical components.

Plug in the power cord (see page 17). Next, locate the power switch on the treadmill frame near the power cord. Press the power switch into the reset position.

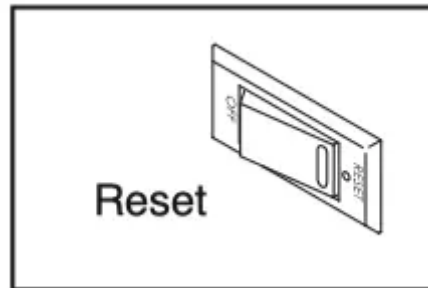

Next, stand on the foot rails of the treadmill. Locate the clip (A) attached to the key (B), and slide the clip securely onto the waistband of your clothes. Then, insert the key into the console. **Note:** It may take some time for the console to be ready for use. **IMPORTANT:** In an emergency, the key can be pulled from the console, causing the walking belt to slow to a stop. Test the clip by carefully taking a few steps backward; if the key is not pulled from the console, adjust the position of the clip.

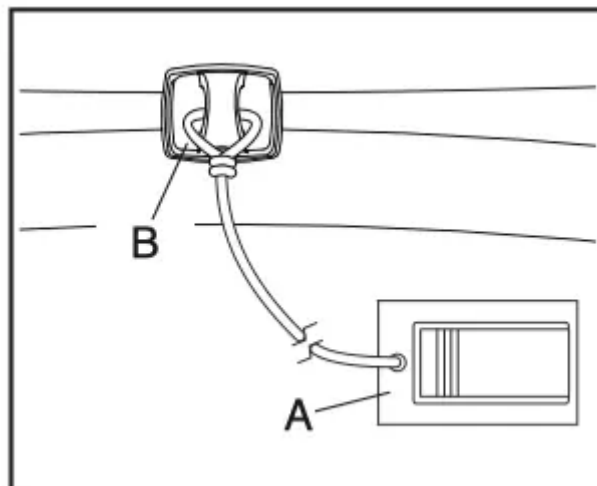

Note: The console can display speed and distance in either miles or kilometers. To find which unit of measurement is selected, see HOW TO USE THE EQUIPMENT SETTINGS SECTION on page 25. For simplicity, all instructions in this section refer to miles.

HOW TO USE THE TOUCH SCREEN

The console features a tablet with a full-color touch screen. The following information will help you become familiar with the tablet's advanced technology:

- The console functions similarly to other tablets. You can slide or flick your finger against the screen to move certain images on the screen, such as the displays in a workout (see step 5 on page 21). However, you cannot zoom in and out by sliding your fingers on the screen.
- The screen is not pressure sensitive. You do not need to press hard on the screen.
- To type information into a text box, touch the text box to view the keyboard. To use numbers or other characters on the keyboard, touch the ?123 button. To view more characters, touch the ~[< button. Touch the ?123 button again to return to the number keyboard. To return to the letter keyboard, touch the ABC button. To use a capital character, touch the button with an upward-facing arrow. To use multiple capital characters, touch and hold the arrow button. To return to the lowercase keyboard, touch the arrow button again. To clear the last character, touch the button with a backward-facing arrow and an X.

HOW TO SET UP THE CONSOLE

Before using the treadmill for the first time, set up the console.

1. Connect to your wireless network.

To access the internet, download iFit workouts, and use several other features of the console, the console must be connected to a wireless network. Follow the prompts on the screen to connect the console to your wireless network.

2. Customize settings.

Fill in the form on the screen to set the console to display the desired unit of measurement and your time zone. Note: If you need to change these settings later, see HOW TO USE THE EQUIPMENT SETTINGS SECTION on page 25.

3. Log into or create an iFit account.

Provide your email address, and follow the prompts on the screen to sign up for or log into your iFit account.

4. Tour the console.

The first time you turn on the treadmill, dialogue boxes on the screen will guide you through the features of the console.

5. Check for firmware updates.

First, touch your name in the upper-left corner and touch the Settings button. Next, select the maintenance section. Then, touch the Update button to check for firmware updates using your wireless network. See HOW TO USE THE MAINTENANCE SECTION on page 26 for more information.

6. Calibrate the incline system.

First, touch your name in the upper-left corner. Next, select the settings main menu. Then, select the maintenance section, touch the Calibrate Incline button, and then touch the Begin button to calibrate the incline system. See step 4 on page 26 for more information.

The console is now ready for you to begin working out. The following pages explain the various workouts and other features that the console offers.

To use the manual mode, see page 21. To use a map workout, see page 23. To use a draw your own map workout, see page 23. To use a distance or time workout, see page 24.

To use the workout settings section, see page 25. To use the equipment settings section, see page 25. To use the maintenance section, see page 26. To use the wireless network mode, see page 27. To use the sound system with a Bluetooth® device, see page 28. To use the sound system with an audio cable, see page 28. To adjust the cushions, see page 28.

IMPORTANT: If there are sheets of plastic on the console, remove the plastic. To prevent damage to the walking platform, wear clean athletic shoes while using the treadmill. The first time you use the treadmill, observe the alignment of the walking belt, and center the walking belt if necessary (see page 31).

HOW TO USE THE MANUAL MODE

1. Insert the key into the console.

See HOW TO TURN ON THE POWER on page 19. Note: It may take some time for the console to be ready for use.

2. Select the main menu.

When you turn on the power, the main menu will appear after the console boots up. If you are in a workout or the settings menu, touch the back arrow or the x on the screen to return to the main menu.

Note: If you plan to use a chest heart rate monitor with the console while you exercise, you must put on the chest heart rate monitor before you start the walking belt. The console will automatically search for the chest heart rate monitor for 30 seconds when you start the walking belt at the beginning of each workout.

3. Start the walking belt and adjust the speed.

Touch the Manual Start button in the upper-right corner of the screen or press the Start button on the console to start the walking belt. The walking belt will begin to move at a low speed. As you exercise, change the speed of the walking belt as desired by pressing the Speed increase and decrease buttons. Each time you press one of the buttons, the speed setting will change by 0.1 mph; if you hold down the button, the speed setting will change in increments of 0.5 mph.

If you press one of the numbered speed buttons, the walking belt will gradually change speed until it reaches the selected speed setting.

Note: When the incline setting is below 0%, you will not be able to select the highest speed settings.

To stop the walking belt, press the Stop button or tap the middle of the screen. To restart the walking belt, press the Start button.

4. Change the incline of the treadmill as desired.

To change the incline of the treadmill, press the Incline increase and decrease buttons or one of the numbered incline buttons. Each time you press one of the buttons, the incline will gradually change until it reaches the selected incline setting.

Note: If the walking belt is moving at a high speed and you adjust the incline below 0%, the speed of the walking belt may automatically decrease.

Note: The first time you use the treadmill, you must calibrate the incline system (see step 4 on page 26).

5. Monitor your progress with the display modes.

The console offers several display modes. The display mode that you select will determine which workout information is shown. To select the desired display mode or to view statistics and charts, drag down on the screen. You can also touch the + button in the lower-right corner of the screen to view stats or charts.

As you walk or run on the treadmill, the screen can show the following workout information:

- The incline level of the treadmill
- Your vertical gain
- Your vertical loss
- The elapsed time
- The approximate number of calories you have burned
- The approximate number of calories you are burning per hour
- Your heart rate (see step 6)
- Your average heart rate
- The distance that you have walked or run
- Your pace
- The speed of the walking belt
- The average speed of the walking belt
- A track representing 1/4 mile (400 m)

If desired, adjust the volume by pressing the volume buttons on the console.

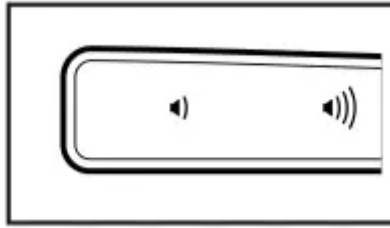

To pause the workout, tap the screen or press the Stop button on the console. To continue the workout, touch the Resume button or the Start button. To end the workout, touch the Finish button.

6. Measure your heart rate if desired.

You can measure your heart rate using either the handgrip heart rate monitor or a compatible heart rate monitor. For information about purchasing an optional chest heart rate monitor, see page 27.

If you use the chest heart rate monitor, you must put it on before you start the walking belt. The console will automatically search for the chest heart rate monitor for 30 seconds when you start the walking belt at the beginning of each workout.

Note: If you use the handgrip heart rate monitor and a chest heart rate monitor at the same time, the chest heart rate monitor will have priority. Note: The console is compatible with Bluetooth Smart heart rate monitors.

Before using the handgrip heart rate monitor, remove the sheets of plastic from the metal contacts (C). In addition, make sure that your hands are clean.

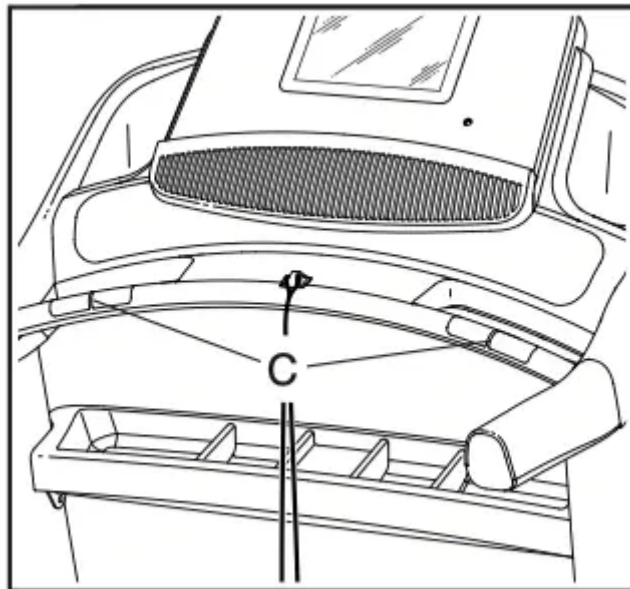

To measure your heart rate, stand on the foot rails and hold the contacts with your palms for approximately ten seconds; avoid moving your hands. When your pulse is detected, your heart rate will be shown. For the most accurate heart rate reading, continue to hold the contacts for about 15 seconds.

7. Turn on the fan if desired.

The fan features several speed settings. Press the fan buttons repeatedly to select a fan speed or to turn on or turn off the fan.

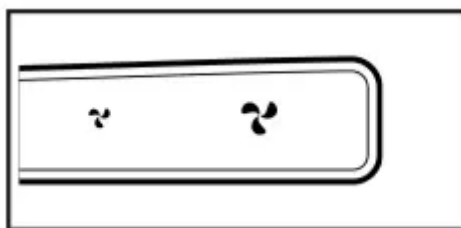

8. When you are finished exercising, remove the key from the console.

Step onto the walking platform and press the Stop button on the console or tap on the screen. Next, touch the Finish button. A workout summary will appear on the screen. If you wish to save your ETNT14119 workout for future use, you can add it as a favorite by touching the heart button in the upper-right corner of the screen. You may also be able to either save or publish your results using one of the options on the screen. Then, remove the key from the console and put it in a secure place.

When you are finished using the treadmill, press the power switch into the off position and unplug the power cord. **IMPORTANT:** If you do not do this, the treadmill's electrical components may wear prematurely.

HOW TO USE A MAP WORKOUT

Note: To use a map workout, the console must be connected to a wireless network (see HOW TO USE THE WIRELESS NETWORK MODE on page 27).

1. Insert the key into the console.

See HOW TO TURN ON THE POWER on page 19.

2. Select the main menu or the workout library.

Touch the Home or Browse buttons on the screen to select either the main menu or the workout library.

3. Select a map workout.

To select a map workout, touch the desired button on the screen. Note: The featured map workouts on your console will change periodically. If you wish to save a workout for future use, you can add it as a favorite by touching the heart button in the upper-right corner of the screen. To draw your own map workout, see this page.

The screen will show the duration and distance of the workout and the approximate number of calories you will burn during the workout.

4. Start the workout.

Touch the Start button to start the workout. A moment after you touch the button, the walking belt will begin to move. Hold the handrails and begin walking.

During the workout, a map on the screen will show your progress.

The workout will function in the same way as the manual mode (see pages 21 to 22).

When you reach the end of the workout, the walking belt will slow to a stop, and a workout summary will appear on the screen. After you view the workout summary, touch the Finish button to return to the main menu. You may also be able to either save or publish your results using one of the options on the screen.

5. Monitor your progress with the display modes.

See step 5 on page 21.

6. Measure your heart rate if desired.

See step 6 on page 22.

7. Turn on the fan if desired.

See step 7 on page 22.

8. When you are finished exercising, remove the key from the console.

See step 8 on page 22.

HOW TO USE A DRAW YOUR OWN MAP WORKOUT

Note: To use a draw your own map workout, the console must be connected to a wireless network (see HOW TO USE THE WIRELESS NETWORK MODE on page 27).

1. Insert the key into the console.

See HOW TO TURN ON THE POWER on page 19.

2. Select a draw your own map workout.

To select a draw your own map workout, touch the Create button on the screen.

3. Draw your map.

Navigate to the area on the map where you want to draw your workout by sliding your fingers on the screen. Tap the screen to add the start point for your workout. Then, tap the screen to add the end point for your workout. Note: If you want to start and end the workout at the same point, use the Loop or Out & Back buttons on the left side of the screen. You can also select whether you want your workout to snap to the road.

If you make a mistake, you can use the Undo button on the left side of the screen.

The screen will display the elevation and distance statistics for your workout. If desired, you can change the default speed.

4. Save your workout.

Touch the Save New Workout button in the lowerleft corner of the screen. If desired, change the title of the workout or add a description, and then press the > symbol on the screen.

5. Start the workout.

Touch the Start button on the screen to start the workout. A moment after you touch the button, the walking belt will begin to move. Hold the handrails and begin walking. See step 4 on page 23 for more information.

6. Monitor your progress with the display modes.

See step 5 on page 21.

7. Measure your heart rate if desired.

See step 6 on page 22.

8. Turn on the fan if desired.

See step 7 on page 22.

9. When you are finished exercising, remove the key from the console.

See step 8 on page 22.

HOW TO USE A DISTANCE OR TIME WORKOUT

Note: To use a distance or time workout, the console must be connected to a wireless network (see HOW TO USE THE WIRELESS NETWORK MODE on page 27). An iFit account is also required.

1. Add workouts to your schedule on iFit.

On your computer, smartphone, tablet, or other device, open an internet browser, go to iFit.com, and sign in to your iFit account.

Next, navigate to Menu > Library on the website. Browse the workout programs in the library and join the desired workouts.

Then, navigate to Menu > Schedule to view your schedule. All of the workouts that you have joined will appear on your schedule; you can arrange or delete the workouts on your schedule as desired.

Take time to explore the iFit.com website before you log out.

2. Insert the key into the console.

See HOW TO TURN ON THE POWER on page 19.

3. Select the main menu.

See step 2 on page 21.

4. Log in to your iFit account.

If you have not already done so, touch the Login button to log in to your iFit account. The screen will ask for your iFit username and password. Enter them and touch the Submit button. Touch the Cancel button to exit the login screen.

5. Select a distance or time workout that you have previously added to your schedule on iFit.

Touch the calendar icon to download a distance or time workout from your schedule.

Note: Before workouts will download, you must add them to your schedule on iFit.

When you select a distance or time workout, the screen will show the name, the estimated duration, and the distance of the workout.

6. Start the workout.

See step 4 on page 23. Note: During a distance or time workout, the display will not show a map.

7. Monitor your progress with the display modes.

See step 5 on page 21. The screen will show the elapsed distance or time, and the remaining distance or time.

8. Measure your heart rate if desired.

See step 6 on page 22.

9. Turn on the fan if desired.

See step 7 on page 22.

10. When you are finished exercising, remove the key from the console.

See step 8 on page 22.

HOW TO USE THE WORKOUT SETTINGS SECTION

1. Select the settings main menu.

Insert the key into the console (see HOW TO TURN ON THE POWER on page 19). Next, select the main menu (see step 2 on page 21). Then, touch your name in the upper-left corner of the screen, and touch the gears button to select the settings main menu.

2. Select the workout section.

In the settings main menu, scroll to the Workout section.

3. Customize settings.

To customize settings, touch the desired category, and then touch the toggle button at the side of the category name.

4. Exit the workout section.

To exit the workout section, touch the back button on the screen.

HOW TO USE THE EQUIPMENT SETTINGS SECTION

1. Select the settings main menu.

See step 1 at the left.

2. Select the equipment settings section.

In the settings main menu, scroll to the Equipment Settings section. Note: Slide or flick the screen to scroll up or down through the options if necessary.

3. Customize the unit of measurement and other settings.

To customize the unit of measurement, the timezone, or other settings, touch the desired category, and then touch the toggle button at the side of the category name.

4. View machine information.

Touch the Machine Info button to view information about your treadmill. After you view the information, touch the back button on the screen.

5. Exit the equipment settings section.

To exit the equipment settings section, touch the back button on the screen.

HOW TO USE THE MAINTENANCE SECTION

1. Select the settings main menu.

See step 1 on page 25.

2. Select the maintenance section.

In the settings main menu, scroll to the Maintenance section.

3. Update the console firmware.

For the best results, regularly check for firmware updates.

Touch the Update button to check for firmware updates using your wireless network. The update will begin automatically.

To avoid damaging the treadmill, do not turn off the power or remove the key while the firmware is being updated.

The screen will show the progress of the update. When the update is complete, the treadmill will turn off and then turn back on. If it does not, press the power switch into the off position, wait for several seconds, and then press the power switch into the reset position. Note: It may take a few minutes for the console to be ready for use.

Note: Occasionally, a firmware update may cause the console to function slightly differently. These updates are always designed to improve your exercise experience.

4. Calibrate the incline system of the treadmill.

Touch the Calibrate Incline button. Then, touch the Begin button to calibrate the incline system. The treadmill will automatically rise to the maximum incline level, lower to the minimum incline level, and then return to the starting position. This will calibrate the incline system. Touch the Cancel button to return to the maintenance section. When the incline system is calibrated, touch the Finish button.

IMPORTANT: Keep pets, feet, and other objects away from the treadmill while the incline system is calibrating. In an emergency, pull the key from the console to stop the incline calibration.

5. Exit the maintenance section.

To exit the maintenance section, touch the back button on the screen.

HOW TO USE THE WIRELESS NETWORK MODE

The console features a wireless network mode that allows you to set up a wireless network connection.

1. Select the main menu.

See step 2 on page 21.

2. Select the wireless network mode.

Touch your name in the upper-left corner of the screen, then touch the Wi-Fi® symbol to enter the wireless network mode.

3. Enable Wi-Fi.

Make sure that Wi-Fi is enabled. If it is not, touch the Wi-Fi toggle to enable a wireless connection.

4. Set up and manage a wireless network connection.

When Wi-Fi is enabled, the screen will show a list of available networks. Note: It may take several seconds for the list of wireless networks to appear.

Note: You must have your own wireless network and an 802.11b/g/n router with SSID broadcast enabled (hidden networks are not supported).

When a list of networks appears, touch the desired network. Note: You will need to know your network name (SSID). If your network has a password, you will also need to know the password.

An information box will ask if you want to connect to the wireless network. Touch the Connect button to connect to the network or touch the Cancel button to return to the list of networks. If the network has a password, touch the password entry box. A keyboard will appear on the screen. To view the password as you type it, touch the Show Password checkbox.

To use the keyboard, see HOW TO USE THE TOUCH SCREEN on page 19.

When the console is connected to your wireless network, a checkmark will appear next to the wireless network name. Then, touch the back button on the screen to return to the wireless network mode.

To disconnect from a wireless network, touch and hold the name of the Wi-Fi network, then touch Forget Network.

If you are having problems connecting to an encrypted network, make sure that your password is correct. Note: Passwords are case-sensitive.

Note: The console supports unsecured and secured (WEP, WPA™, and WPA2™) encryption.

A broadband connection is recommended; performance depends on connection speed.

Note: If you have questions after following these instructions, go to support.iFit.com for assistance.

5. Exit the wireless network mode.

To exit the wireless network mode, touch the back button on the screen.

THE OPTIONAL CHEST HEART RATE MONITOR

Whether your goal is to burn fat or to strengthen your cardiovascular system, the key to achieving the best results is to maintain the proper heart rate during your workouts. The optional chest heart rate monitor will enable you to continuously monitor your heart rate while you exercise, helping you to reach your personal fitness goals. To purchase a chest heart rate monitor, please see the front cover of this manual.

Note: The console is compatible with all Bluetooth Smart heart rate monitors.

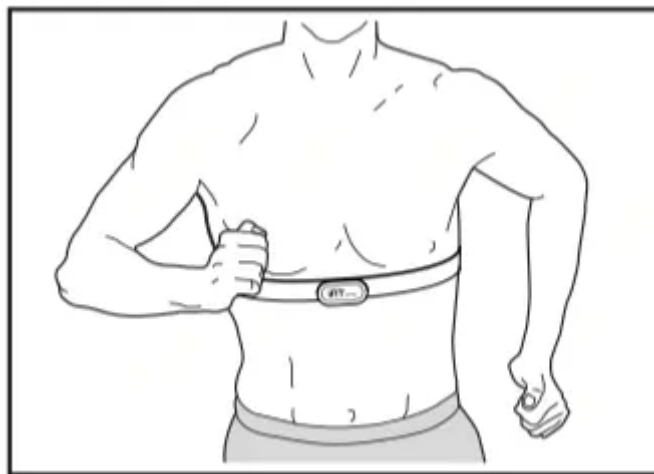

HOW TO USE THE SOUND SYSTEM WITH A BLUETOOTH DEVICE

- 1. Place or hold your Bluetooth-enabled device near the console.**
- 2. Turn on your device's Bluetooth setting.**
- 3. Pair your device to the console.**

Press and hold the Bluetooth button on the console's speaker grill for 3 seconds. The Bluetooth speakers will enter pairing mode. When your device and the console pair successfully, the audio from your device will play through the console's speakers.

Note: The console can save 8 devices in its memory. If you have previously paired your device to the console, you can simply press the Bluetooth button to connect your device to the console.

4. Erase the console's device memory if necessary.

If you need to erase all the Bluetooth-enabled devices saved in the console's memory, press and hold the Bluetooth button for 10 seconds.

HOW TO USE THE SOUND SYSTEM WITH AN AUDIO CABLE

To play music or audio books through the console sound system while you exercise, plug a 3.5 mm male to 3.5 mm male audio cable (not included) into the jack on the console and into a jack on your personal audio player; make sure that the audio cable is fully plugged in. **Note:** To purchase an audio cable, see your local electronics store.

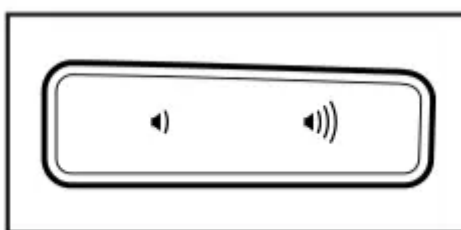

Next, press the play button on your personal audio player. Adjust the volume level using the volume increase and decrease buttons on the console or the volume control on your personal audio player.

HOW TO ADJUST THE CUSHIONS

The treadmill features cushions that reduces the impact as you walk or run on the treadmill.

Remove the key from the console and unplug the power cord.

For a more firm walking platform, turn the cushion knob (D) a half turn counterclockwise until you feel it lock into place. For a less firm walking platform, turn the cushion knob a half turn clockwise until you feel it lock into place. **Note:** The faster you run on the treadmill, or the more you weigh, the firmer the walking platform should be.

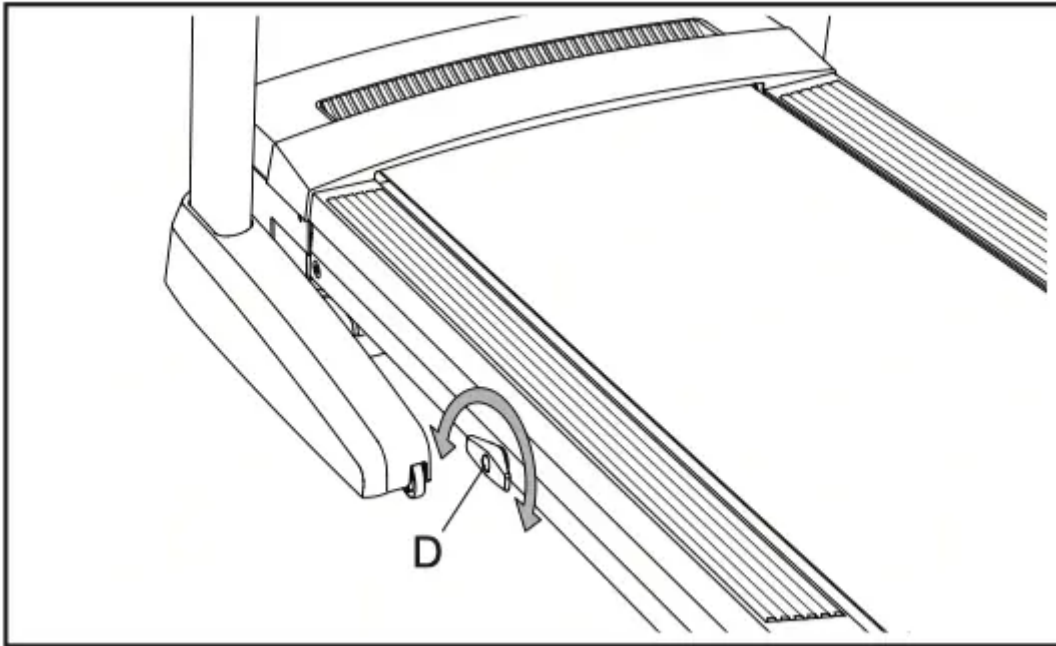

HOW TO FOLD AND MOVE THE TREADMILL

HOW TO FOLD THE TREADMILL

To avoid damaging the treadmill, adjust the incline to zero before you fold the treadmill. Then, remove the key and unplug the power cord. **CAUTION:** You must be able to safely lift 45 lbs. (20 kg) to raise, lower, or move the treadmill.

1. Hold the metal frame (A) firmly in the location shown by the arrow below. **CAUTION:** Do not hold the frame by the plastic foot rails. Bend your legs and keep your back straight.

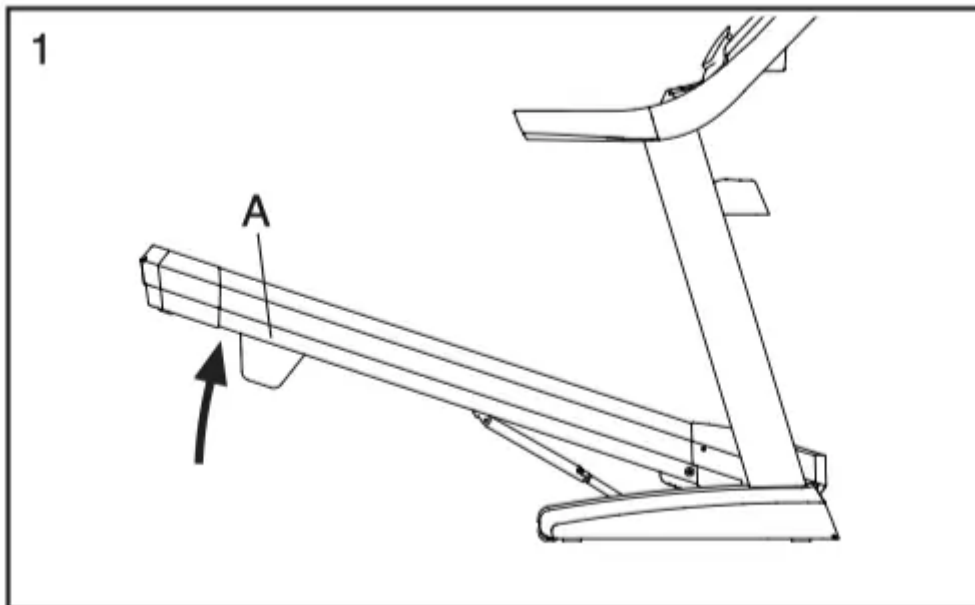

2. Raise the frame (A) until the storage latch (B) locks in the storage position. **CAUTION:** Make sure that the storage latch locks.

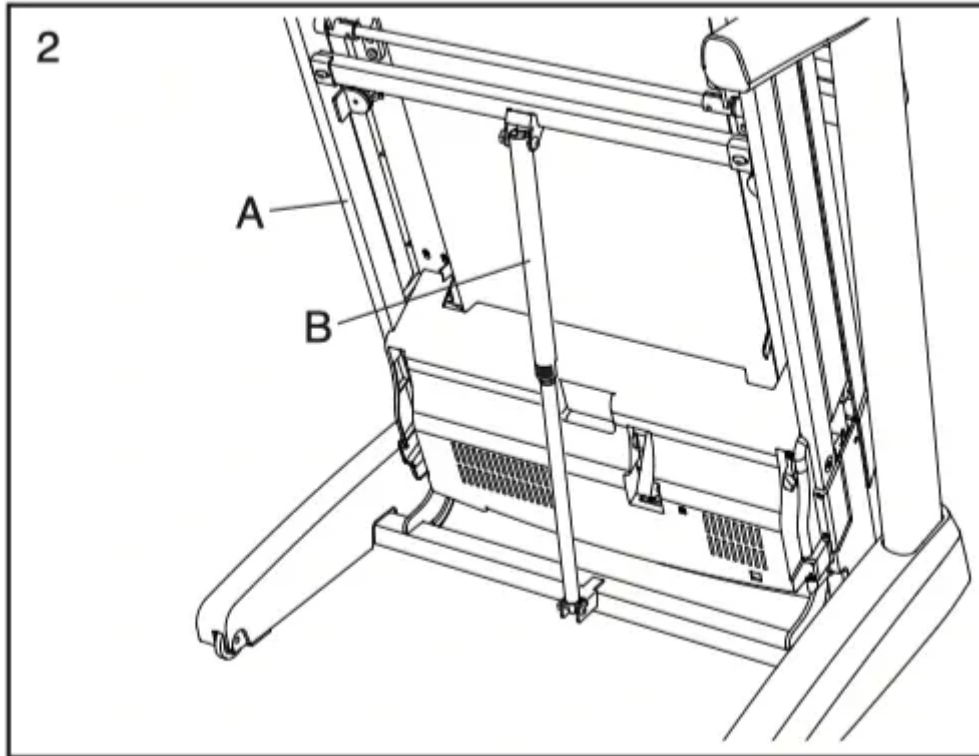

To protect the floor or carpet, place a mat under the treadmill. Keep the treadmill out of direct sunlight. Do not leave the treadmill in the storage position in temperatures above 85°F (30°C).

HOW TO MOVE THE TREADMILL

Before moving the treadmill, fold it as described at the left. **CAUTION:** Make sure that the storage latch is in the locked position. Moving the treadmill may require two people.

1. Hold the frame (A) and one of the handrails (C), and place one foot against a wheel (D).

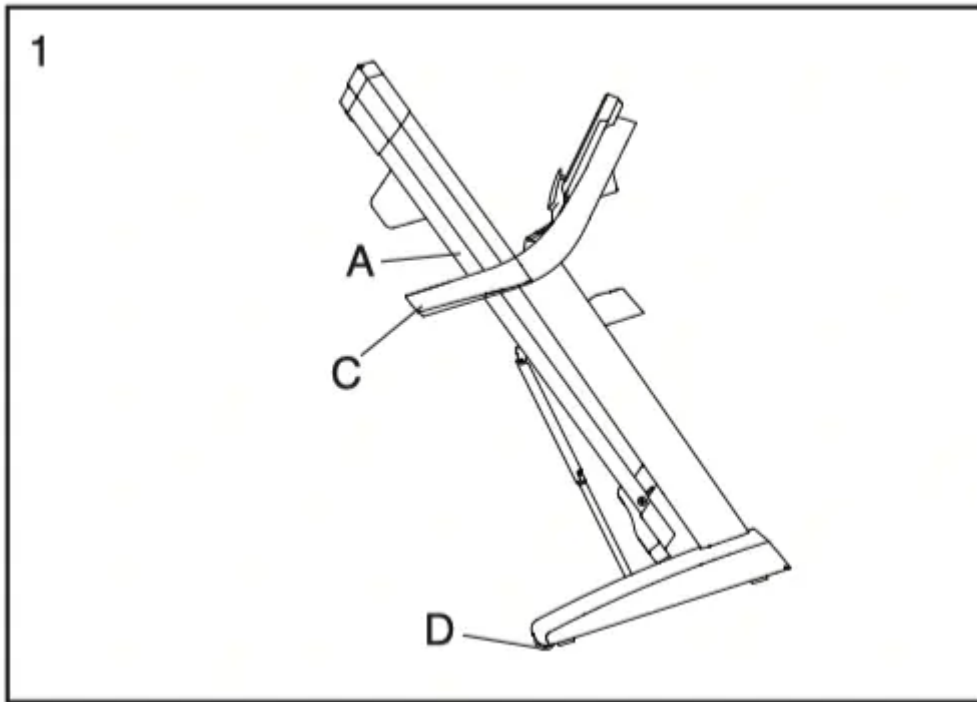

2. Pull back on the handrail until the treadmill will roll on the wheels, and carefully move it to the desired location. **CAUTION:** Do not move the treadmill without tipping it back, do not pull on the frame, and do not move the treadmill over an uneven surface.
3. Place one foot against a wheel, and carefully lower the treadmill.

HOW TO LOWER THE TREADMILL FOR USE

1. Push the upper end of the frame forward, and gently press the upper part of the storage latch with your foot at the same time.
2. While pressing the storage latch with your foot, pull the upper end of the frame toward yourself.
3. Step back and let the frame lower to the floor.

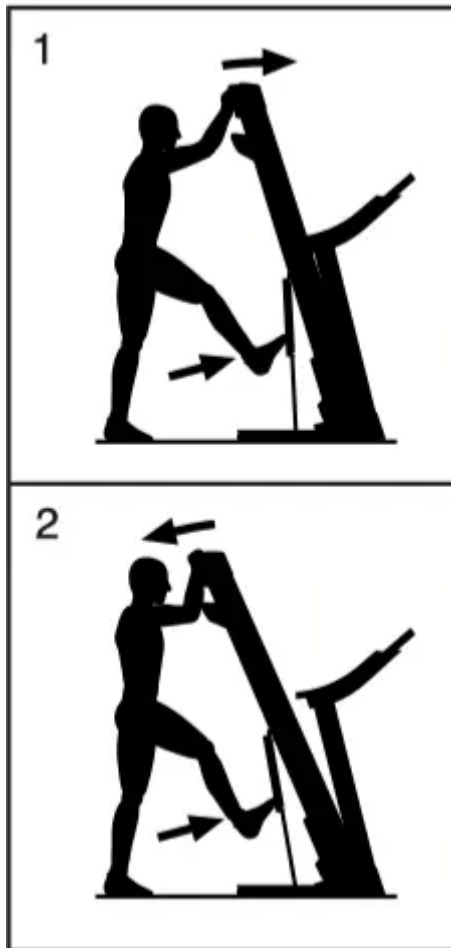

MAINTENANCE AND TROUBLESHOOTING

MAINTENANCE

Regular maintenance is important for optimal performance and to reduce wear. Inspect and properly tighten all parts each time the treadmill is used. Replace any worn parts immediately.

Regularly clean the treadmill and keep the walking belt clean and dry. First, press the power switch into the off position and unplug the power cord. Wipe exterior parts of the treadmill with a damp cloth and a small amount of mild soap. **IMPORTANT:** Do not spray liquids directly onto the treadmill. To avoid damage to the console, keep liquids away from the console. Then, thoroughly dry the treadmill with a soft towel.

TROUBLESHOOTING

Most treadmill problems can be solved by following the simple steps below. Find the symptom that applies, and follow the steps listed. If further assistance is needed, see the front cover of this manual.

SYMPTOM: The power does not turn on

- a. Make sure that the power cord is plugged into a surge suppressor, and that the surge suppressor is plugged into a properly grounded outlet (see page 17). Use only a surge suppressor that meets all of the specifications described on page 17. **IMPORTANT:** If the treadmill is connected to an AFCI-equipped outlet and your circuit breaker trips repeatedly when the treadmill is used, see the front cover of this manual to purchase an arc filter.
- b. After the power cord has been plugged in, make sure that the key is inserted into the console.
- c. Check the power switch located on the treadmill frame near the power cord. If the switch protrudes as shown, the switch has tripped. To reset the power switch, wait for five minutes and then press the switch back in.

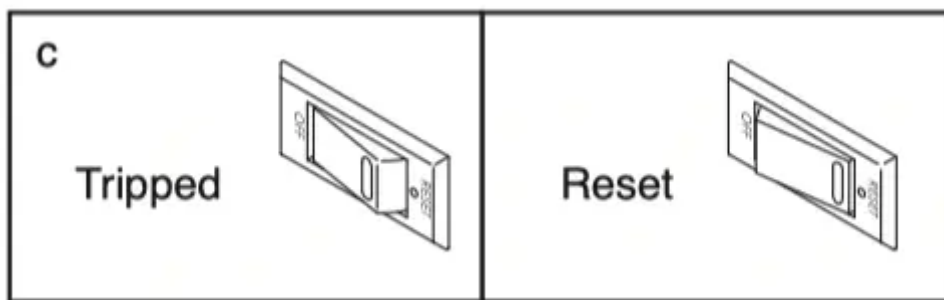

SYMPTOM: The power turns off during use

- a. Check the power switch (see the drawing above). If the switch has tripped, wait for five minutes and then press the switch back in.
- b. Make sure that the power cord is plugged in. If the power cord is plugged in, unplug it, wait for five minutes, and then plug it back in.
- c. Remove the key from the console, and then reinsert it.
- d. If the treadmill still will not run, please see the front cover of this manual.

SYMPTOM: The incline of the treadmill does not change correctly

- a. Calibrate the incline system (see step 4 on page 26).

SYMPTOM: The treadmill will not connect to the wireless network

- a. Make sure that the wireless settings on the console are correct (see page 27).
- b. Make sure that the settings for your wireless network are correct.
- c. If you still have questions, see the front cover of this manual.

SYMPTOM: The walking belt slows when walked on

- a. Use only a surge suppressor that meets all of the specifications described on page 17.
- b. If the walking belt is overtightened, treadmill performance may decrease and the walking belt may become damaged. Remove the key and UNPLUG THE POWER CORD. Using the hex key, turn both idler roller screws (A) counterclockwise, 1/4 of a turn. When the walking

belt is properly tightened, you should be able to lift each edge of the walking belt 2 to 3 in. (5 to 7 cm) off the walking platform.

Be careful to keep the walking belt centered. Then, plug in the power cord, insert the key, and walk on the treadmill for a few minutes. Repeat until the walking belt is properly tightened.

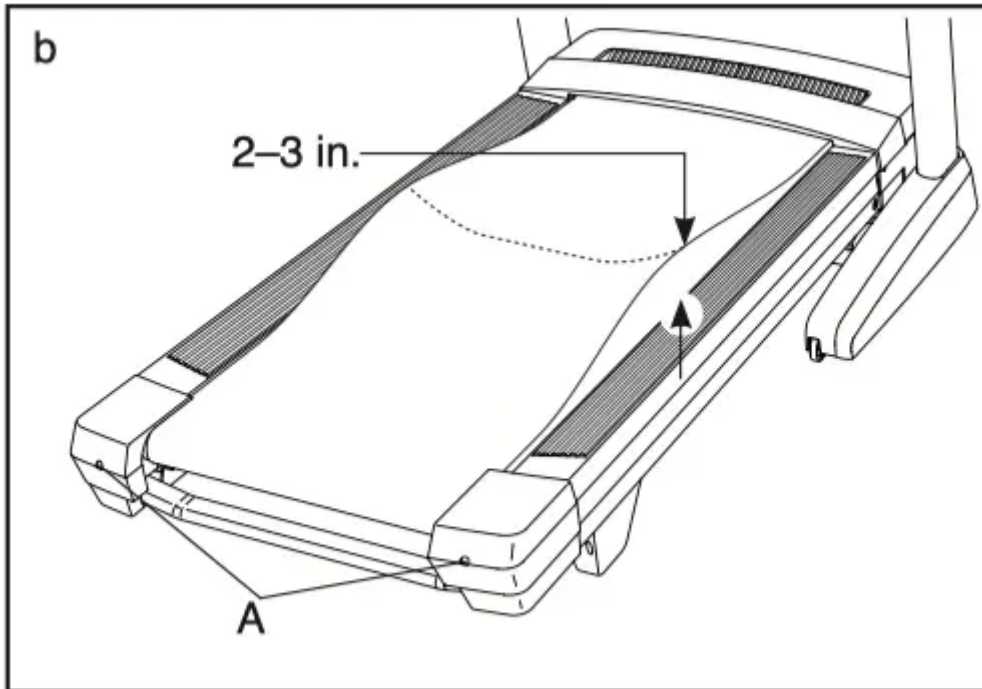

c. Your treadmill features a walking belt coated with high-performance lubricant. **IMPORTANT:** Never apply silicone spray or other substances to the walking belt or the walking platform unless instructed to do so by an authorized service representative. Such substances may deteriorate the walking belt and cause excessive wear. If you suspect that the walking belt needs more lubricant, see the front cover of this manual.

d. If the walking belt still slows when walked on, see the front cover of this manual.

SYMPTOM: The walking belt is off-center or slips when walked on

a. If the walking belt is off-center, first remove the key and **UNPLUG THE POWER CORD**. If the walking belt has shifted to the left, use the hex key to turn the left idler roller screw clockwise 1/2 of a turn; if the walking belt has shifted to the right, turn the left idler roller screw counterclockwise 1/2 of a turn. Be careful not to overtighten the walking belt. Then, plug in the power cord, insert the key, and walk on the treadmill for a few minutes. Repeat until the walking belt is centered.



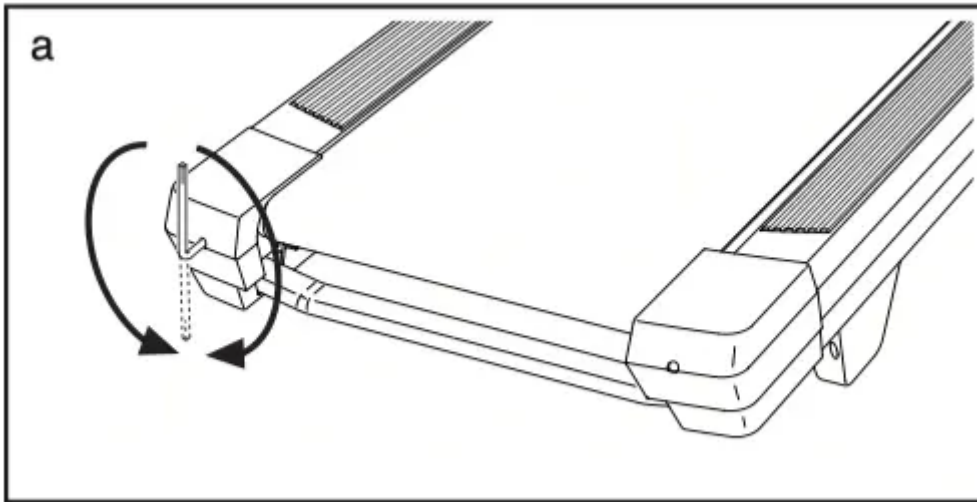

b. If the walking belt slips when walked on, first remove the key and UNPLUG THE POWER CORD. Using the hex key, turn both idler roller screws clockwise, 1/4 of a turn. When the walking belt is correctly tightened, you should be able to lift each edge of the walking belt 2 to 3 in. (5 to 7 cm) off the walking platform. Be careful to keep the walking belt centered. Then, plug in the power cord, insert the key, and walk on the treadmill for a few minutes. Repeat until the walking belt is properly tightened.

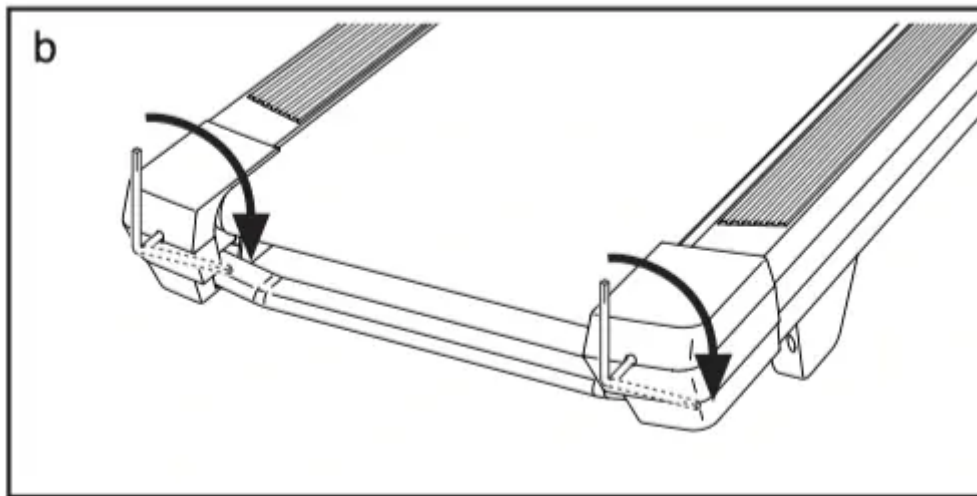

SYMPTOM: The displays of the console do not function properly

a. If the console does not boot up properly, or if the console freezes and does not respond, reset the console to the factory default settings. **IMPORTANT:** Doing this will erase all the custom settings you have made to the console. Resetting the console requires two people. First, press the power switch into the off position. Next, locate the small reset opening (B) on the back edge of the console. Using a bent paper clip (C), press and hold the reset button inside the opening, and have a second person press the power switch into the on position. Continue holding the reset button until the console turns on. When the reset operation is complete, the console will turn off and then turn back on. If it does not, use the power switch to turn the treadmill off and then on again. Once the console turns on, check for firmware



updates (see HOW TO USE THE MAINTENANCE SECTION on page 26). **Note:** It may take a few minutes for the console to be ready for use.

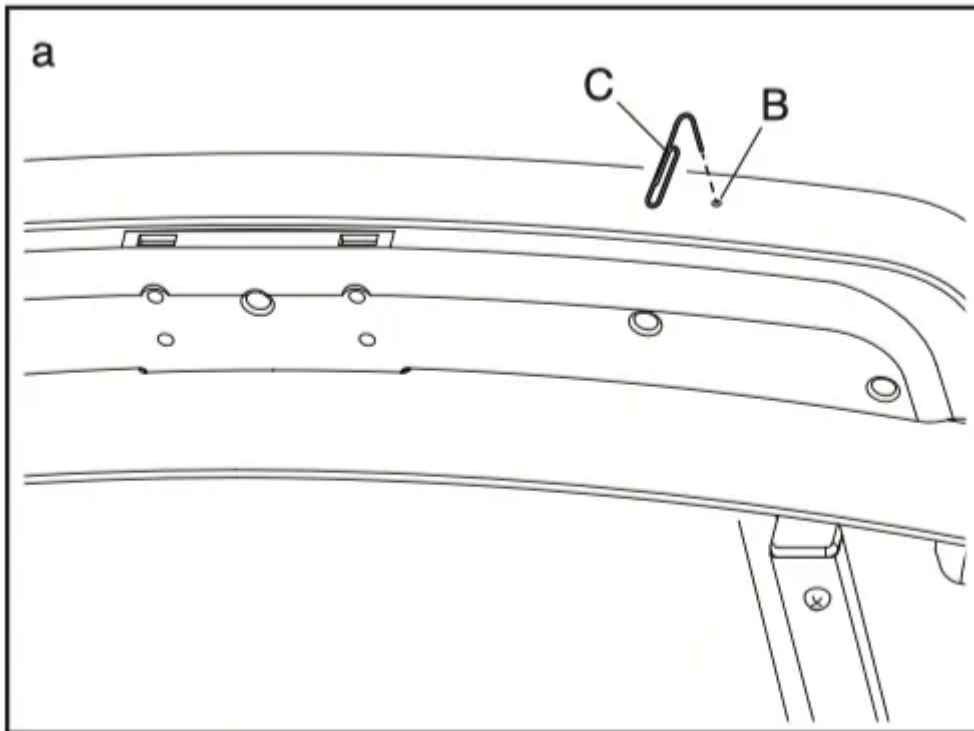

EXERCISE GUIDELINES



WARNING: Before any exercise program, consult your physician. This is especially important for persons over age 35 or persons with pre-existing health problems.

The heart rate monitor is not a medical device. Various factors may affect the accuracy of heart rate readings. The heart rate monitor is intended only as an exercise aid in determining heart rate trends in general.

These guidelines will help you to plan your exercise program. For detailed exercise information, obtain a reputable book or consult your physician. Remember, proper nutrition and adequate rest are essential for successful results.

EXERCISE INTENSITY

Whether your goal is to burn fat or to strengthen your cardiovascular system, exercising at the proper intensity is the key to achieving results. You can use your heart rate as a guide to find the proper intensity level. The chart below shows recommended heart rates for fat burning and aerobic exercise.

165	155	145	140	130	125	115	
145	138	130	125	118	110	103	
125	120	115	110	105	95	90	
<hr/>							
20	30	40	50	60	70	80	

To find the proper intensity level, find your age at the bottom of the chart (ages are rounded off to the nearest ten years). The three numbers listed above your age define your “training zone.” The lowest number is the heart rate for fat burning, the middle number is the heart rate for maximum fat burning, and the highest number is the heart rate for aerobic exercise.

Burning Fat—To burn fat effectively, you must exercise at a low intensity level for a sustained period of time. During the first few minutes of exercise, your body uses carbohydrate calories for energy. Only after the first few minutes of exercise does your body begin to use stored fat calories for energy. If your goal is to burn fat, adjust the intensity of your exercise until your heart rate is near the lowest number in your training zone. For maximum fat burning, exercise with your heart rate near the middle number in your training zone.

Aerobic Exercise—If your goal is to strengthen your cardiovascular system, you must perform aerobic exercise, which is activity that requires large amounts of oxygen for prolonged periods of time. For aerobic exercise, adjust the intensity of your exercise until your heart rate is near the highest number in your training zone.

WORKOUT GUIDELINES

Warming Up—Start with 5 to 10 minutes of stretching and light exercise. A warm-up increases your body temperature, heart rate, and circulation in preparation for exercise.

Training Zone Exercise—Exercise for 20 to 30 minutes with your heart rate in your training zone. (During the first few weeks of your exercise program, do not keep your heart rate in your training zone for longer than 20 minutes.) Breathe regularly and deeply as you exercise; never hold your breath.

Cooling Down—Finish with 5 to 10 minutes of stretching. Stretching increases the flexibility of your muscles and helps to prevent post-exercise problems.

EXERCISE FREQUENCY

To maintain or improve your condition, complete three workouts each week, with at least one day of rest between workouts. After a few months of regular exercise, you may complete up to five

workouts each week, if desired. Remember, the key to success is to make exercise a regular and enjoyable part of your everyday life.

Warning

This content is compiled from multiple sources and is provided for reference purposes only. It may not be complete or fully applicable to all situations. If you are unable to resolve your issue, please contact the product manufacturer or an authorized service provider for official support.

Document generated by [ManualsFile](#)

