

Programming the Water Softener

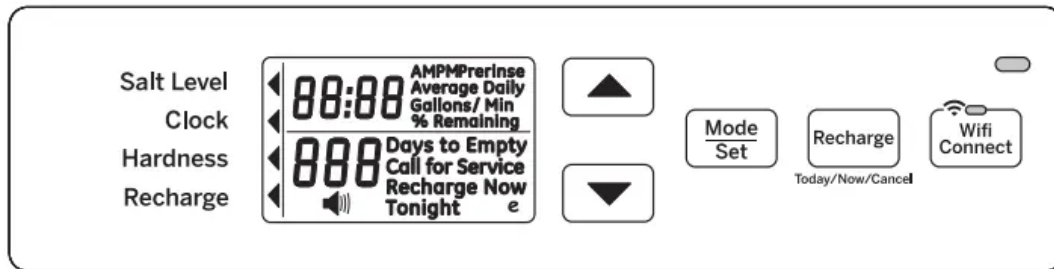

When the transformer is plugged into the electrical outlet, a model code and test number (example: y4.1 & H40) are shown in the display. Then, "12:00 PM" begins to flash. An arrow ◀ is displayed next to CLOCK on the face plate decal.

CONTROL OPERATION:

- CONTROL SETTINGS REQUIRED upon initial installation and after an extended power outage.
- Use the MODE/SET button to scroll arrow ◀ to desired control function set.
- After the mode is selected use the UP ▲ and DOWN ▼ buttons to change the settings of the control.
- Press the MODE/SET button to accept changes.
- A "beep" sounds while pressing buttons for control programming. One beep signals a change in the control display. Repeated beeps mean the control will not accept a change from the button you have pressed, and you should select another button.

SET TIME OF DAY

1. Press MODE/SET button until the arrow ◀ points to CLOCK.
2. Press the UP ▲ or DOWN ▼ buttons to set the present time. UP moves the display ahead; DOWN ▼ sets the time back. Be sure AM and PM is correct.



NOTE: Press buttons and quickly release to slowly advance the display one number at a time. Hold the buttons down for fast advance.

3. When the correct time is shown in the display, press MODE/SET to accept.

SET WATER HARDNESS NUMBER

1. Press the MODE/SET button until the arrow ◀ points to HARDNESS. A flashing 25 will appear in the display.

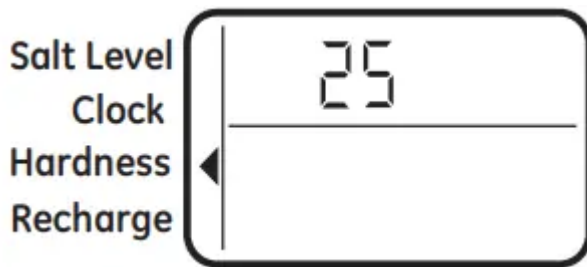

2. Press the UP ▲ or DOWN ▼ buttons to set your water hardness number.

NOTE: If your water supply contains iron, compensate for it by adding to the water hardness number. For example, assume your water is 20 gpg hard and contains 2 ppm iron. Add 5 to the hardness number for each 1 ppm or iron. In this example, you would use 30 for your hardness number.

$$\begin{array}{r} 20 \text{ gpg hardness} \\ 2 \text{ ppm iron} \times 5 = 10 \quad \underline{+10} \\ \text{(times)} \qquad \qquad \qquad 30 \text{ HARDNESS NUMBER} \end{array}$$

3. When the display shows your water hardness (in grains per gallon), press MODE/SET to accept.

You can get the grains per gallon (gpg) hardness of your water supply from a water analysis laboratory. If you are on a municipal supply, call your local water department. Or call Legend Technical Services, an independent laboratory, to request a water hardness test kit at 1.800.949.8220, Option 4. If your report shows hardness in parts per million (ppm) or milligrams per liter (mg/l), simply divide by 17.1 to get the equivalent number of grains per gallon.

SET RECHARGE (STARTING) TIME

1. Press the MODE/SET button until the arrow ◀ points to RECHARGE.





NOTE: A flashing 2:00 AM (factory default) should show in the display. This is a good time for recharge to start (takes about 2 hours) in most households because water is not in use. HARD WATER is bypassed to house faucets during recharge.

If no change is needed, go to step 3. To Change the recharge starting time, follow step 2.

2. Press UP ▲ or DOWN ▼ button to set the desired recharge start time. Be sure to observe the AM or PM as you did when setting the time of day.

3. Press the MODE/SET button to accept.

SET SALT LEVEL

1. Press the MODE/SET button until the arrow points to SALT LEVEL.

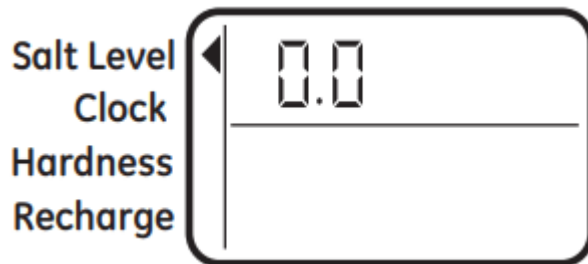

2. Determine level of salt in brine tank using the numbered scale on side of brine well, inside brine tank (see Figure 15).

3. Press UP ▲ or DOWN ▼ button to set the SALT LEVEL to correspond to level on the numbered scale in brine tank.

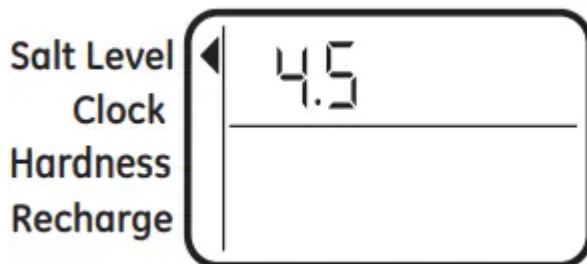

NOTE: Each press of a button changes the level by increments of 0.5 up to 8.0.

Lowering the salt level below zero turns the SALT LEVEL indicator OFF.



4. Press the MODE/SET button to accept. The display shows the present time of day and DAYS TO EMPTY.

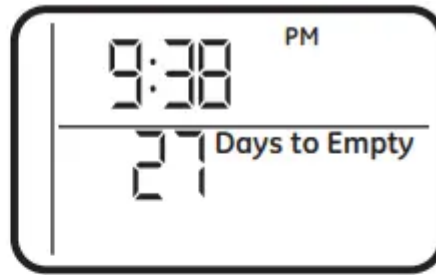
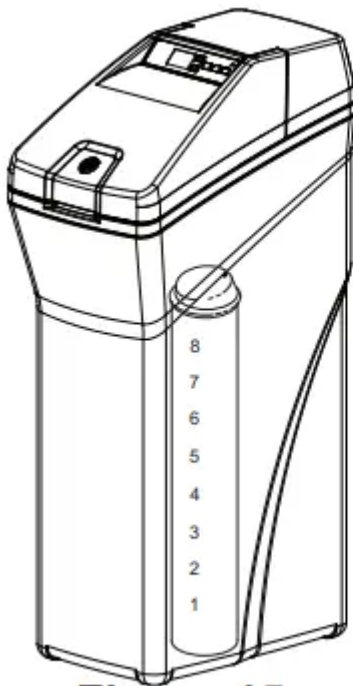

Figure 15

DAYS TO EMPTY

The words DAYS TO EMPTY and a number are shown in the lower half of the display. This information is shown in the normal run display. This is to inform the user of the number of days before the salt level in the brine tank reaches Level 0. There will be salt left in the salt tank, but it may not be sufficient to fully recharge the system. Salt should be added at this time to avoid hard water. The value is updated daily and whenever the SALT LEVEL value is changed.



NOTE: For the first several weeks of operation, the DAYS TO EMPTY may provide erratic operation. For example, the blue indicator light may flash, showing that more salt is required when the actual salt level in the tank is well above the Level 0. In some cases, the DAYS TO EMPTY may even increase over a several week period.

It takes a couple of months for the water softener to learn your water usage pattern. Once it does this, it will accurately determine actual salt usage pattern. During this first period, check salt level

when blue indicator light flashes. If the salt level in the tank is at Level 1 or above, allow system to run. Be sure to reset your salt level indicator each time you add salt to the system.

START A RECHARGE

Press the RECHARGE button and hold for three seconds, until “RECHARGE NOW” begins to flash in the display, starting a recharge. This recharge draws the sanitizing bleach or brine into and through the water softener. Any air remaining in the water softener is purged to the drain. During this time periodically check for leaks.

NOTE: As with all other water system applications, leaks may occur. Leaks may not be immediately apparent. Recheck 24 hours after first recharge cycle is complete.

OPTIONAL CONTROL SETTINGS

The controller display has several options and features.

LOW SALT ALARM

The LOW SALT ALARM, when enabled, will sound the beeper when the DAYS TO EMPTY value is 15 days or less. To change this setting, press and hold the MODE/SET button for 3 seconds or hear a beep. ON (factory default) or OFF will flash in the display. Press the UP ▲ or DOWN ▼ buttons to toggle this feature ON or OFF. Press the MODE/SET button to accept, and the display will move to the SALT EFFICIENCY screen.



SALT EFFICIENCY

When the SALT EFFICIENCY feature is ON, the unit will operate at a salt efficiency of 4000 grains of hardness removed per pound of salt. This mode of operation is the most efficient setting for salt usage, because the system will tend to recharge more often with less salt usage. Turning the feature OFF will tend to lengthen the time between recharge cycles, which will provide the most efficient usage of water, but may use more salt. The degree of difference between these two cycles is highly dependent on the water usage and hardness at particular installation.



NOTE: California Regulations require this feature to be ON for installations in California.

To change the setting, press the UP ▲ or DOWN ▼ buttons to toggle this feature ON or OFF. Press the MODE/SET button to accept, and the display will move to the PRERINSE ON/OFF screen.

PRERINSE

If your water contains sediment, the prerinse feature will remove sediment from the resin bed prior to regeneration. Press the UP ▲ or DOWN ▼ buttons to turn prerinse ON or OFF. Press the MODE/SET button to accept, and the display will move to SET PRERINSE TIME screen. In this screen, you can adjust the duration of the prerinse, in minutes, by pressing the UP ▲ or DOWN ▼ buttons. Press the MODE/ SET button to accept, and the display will move to the ADD BACKWASH TIME screen.

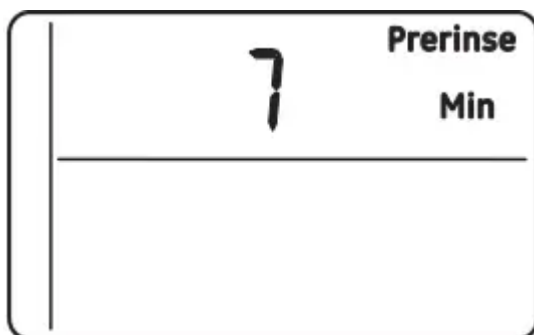
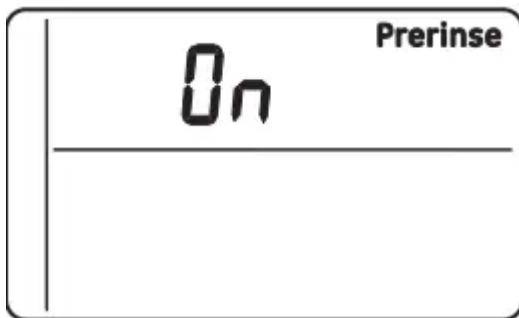

BACKWASH AND FAST RINSE

If you experience salty tasting water after regeneration, you may need to increase the backwash and fast rinse times. The cycle times during regenerations are determined by the softener's

electronic controller. However, you may increase the backwash and fast rinse times. You may add up to 10 minutes.

For Backwash, you can add up to 10 minutes in 1 minute increments, by pressing the UP ▲ button, or subtract time by pressing the DOWN ▼ button.



For Fast Rinse, press MODE/SET and the display moves to the ADD FAST RINSE TIME screen. You can add up to 10 minutes in 1 minute increments, by pressing the UP ▲ button, or subtract time by pressing the DOWN ▼ button. Press the MODE/SET button to accept, and the display will move to the Run Display screen.

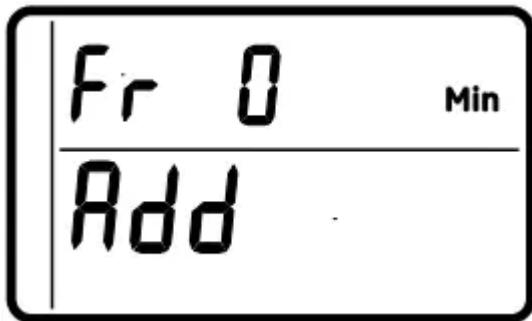

FEATURE: OTHER DATA DISPLAY

These models have an option to have the run display indicate different information. The information displayed on the top half of the display can be changed to one of the following by pressing UP ▲ or DOWN ▼ buttons:

- **CAPACITY REMAINING** – This is the percentage of water softening capacity remaining. Immediately after a regeneration, 100% shows. As water is used, the percentage will decrease until the next regeneration. During regenerations, the percentage increments upward. When present time is displayed, press the DOWN ▼ button; % Remaining will appear in the display. The value shown is between 0 and 100 percent. This value is based on current operating capacity. Pressing the UP ▲ button will return the screen to the previous display.

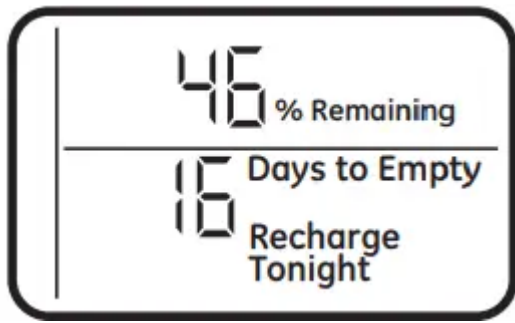

• **AVERAGE DAILY GALLONS** – The figure displayed is the average gallons of water used by the household each day over the past seven-day period. Press the DOWN ▼ button again to display the Average Daily Gallons. Average Daily Gallons will appear in the display. This value is updated every night at midnight. Pressing the UP ▲ button will return the screen to the previous display.

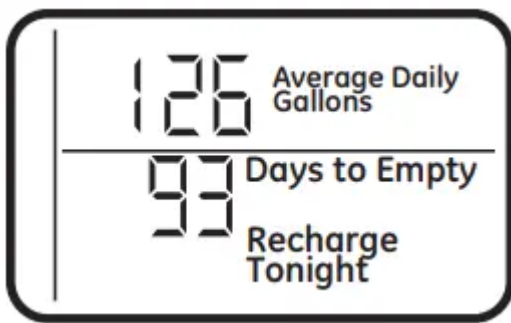

• **FLOW RATE, GPM** – When using soft water, this display shows the flow rate passing through the softener (in gallons per minute). Zero shows if water is not passing through the softener. Press the DOWN ▼ button again to display the flow rate. Gallons/Min will appear in the display. This value is updated every 1»2 second. Pressing the UP ▲ button will return the screen to the previous display. Pressing the DOWN ▼ button will return the screen to the present time display

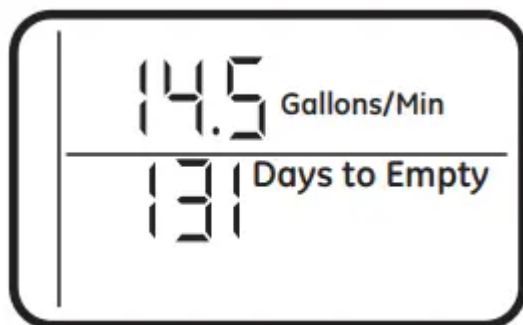

RESETTING TO FACTORY DEFAULT

To reset the electronic controller to its factory default for all settings (time, hardness, etc.):

1. Press the MODE/SET button and hold until the display changes twice to show the flashing mode code.
2. Press the UP ▲ button to display a flashing “SoS”.



3. Press the MODE/SET button and the electronic controller will restart.

4. Set the present time, hardness, etc, as described in the Programming the Water Softener section

POWER OUTAGE MEMORY

If electrical power to the water softener is lost, “memory” built into the timer circuitry will keep all settings for up to 6 hours. While the power is out, the display is blank and the water softener will not regenerate. When electrical power is restored, the following will occur: Reset the present time only if the display is flashing. The HARDNESS and RECHARGE TIME never require resetting unless a change is desired. Even if the clock is incorrect after a long power outage, the softener operates as it should to keep your water soft. However, regenerations may occur at the wrong time of day until you reset the clock to the correct time of day.

NOTE: If the water softener was regenerating when power was lost, it will now finish the cycle.

BLUE INDICATOR LIGHT

Steady blue light indicates that the unit is working correctly. The light flashes when the unit needs attention from the user.

- Light will also flash when power to the unit has been interrupted. Check the PRESENT TIME setting.
- Light flashes and DAYS TO EMPTY flashes - check salt level and add salt as required.
- Light flashes and Err is in the display - electrical problem with system.

LOW SALT SIGNAL

When the DAYS TO EMPTY drops to 15, the blue indicator light and DAYS TO EMPTY in the display will flash every second and the alarm will beep every 30 seconds (from 8:00 AM to 8:00 PM), to notify the user that the unit is running low on salt. As soon as any button is pressed, the alarm will stop beeping. The blue indicator light and DAYS TO EMPTY will continue to flash. Once salt is added to the brine tank and the SALT LEVEL is reset, the DAYS TO EMPTY will be reset.

ERROR SIGNALS

If there is an error code detected, the blue indicator light will flash 4 times every second, the display will flash Err and the alarm will beep every 30 seconds (from 8:00 AM to 8:00 PM) to signal that the softener requires service. The alarm can be turned off by pressing any button, but the blue indicator light and display will continue to flash.



Disconnect the transformer from the wall outlet momentarily, and plug it back in. The normal display will appear. The motor may run for several minutes, as the unit resets. If the problem is not corrected, the error code will reappear in 8 minutes. If Err 6, 7, or 8 appears, it can be cleared by pressing recharge for 5 seconds.

See the Before you Call for Service section to assist in troubleshooting the water softener.

Care and cleaning

ADJUSTING YOUR WATER HARDNESS

The blend adjusting knob (Figure 16) gives the ability to finely adjust hardness of the treated water leaving the water softener. If slightly harder water is desired than is normally delivered by the water softener, the blend adjusting knob can divert a small stream of hard water and blend it with the soft water entering the home. The amount of water diverted is controlled by turning a blend adjusting knob on the end cap of the valve stem.

NOTE: To get full performance from your water softener leave blending valve in the factory closed position.

To make adjustments to water hardness:

1. Hold bypass handle to keep the valve stem from rotating (see Figure 16). Loosen hex nut on blend adjustment knob by turning the hex nut counterclockwise (see Figure 17).
2. TO INCREASE HARDNESS: With the bypass in the service position (see Figure 16) hold the handle to keep the valve stem from rotating and turn the blend adjusting knob counterclockwise up to 2 turns from the closed position. It is recommended that adjustments be made in quarter turn increments over several weeks until the desired hardness is achieved. NOTE: Once an adjustment is made to the blend valve knob the change in water hardness at the homes faucets or shower heads may take several days to be noticed. This

delay is due to the large amounts of already conditioned water in the pipes and water heater that must be exchanged before a change in hardness can be noticed. Have the water tested to determine the actual water hardness.

3. TO DECREASE HARDNESS: With the bypass in the service position (see Figure 16) hold the handle to keep the valve stem from rotating and turn the blend adjusting knob clockwise. When the knob will not turn anymore, hard water is no longer being blended into the soft water.

4. Once the desired hardness is achieved tighten the hex nut (see Figure 17) clockwise until it comes in contact with the bypass stem.

NOTE: To meet the water softener performance specifications and reduction of barium and radium claims the adjustable hardness must be kept in the "OFF" position. The off position is achieved when the blend adjusting knob is fully rotated clockwise until it stops.

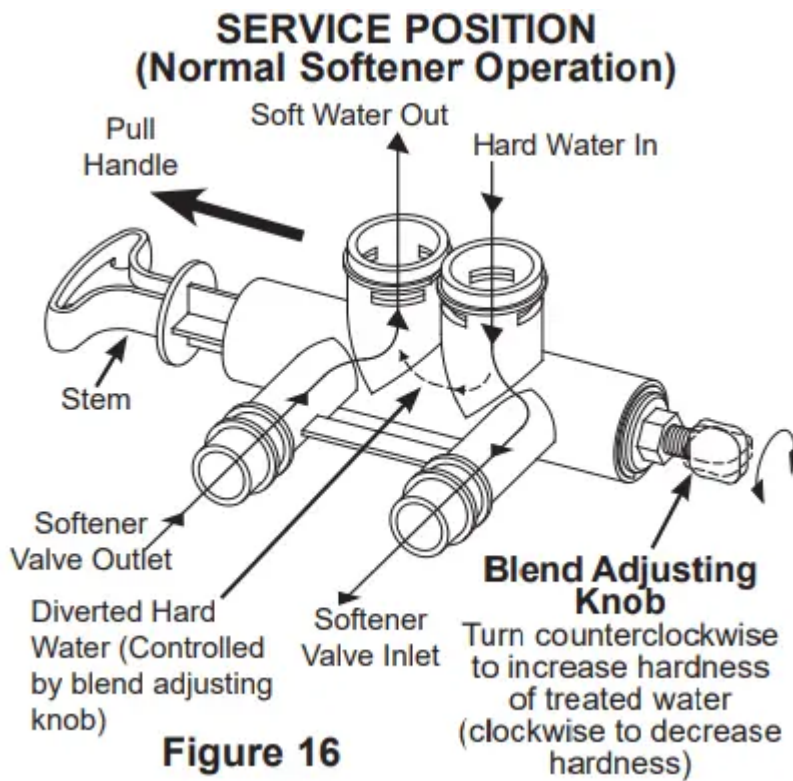

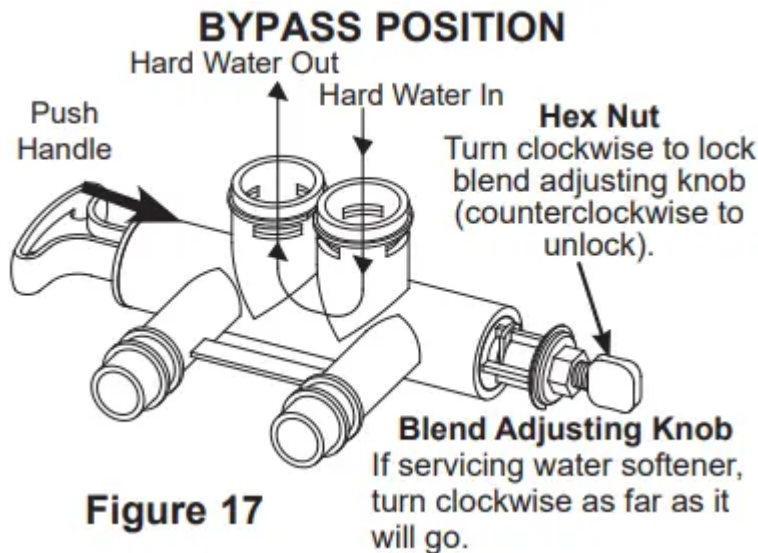

CAUTION If the water softener is to be serviced or disconnected from the bypass valve, the blend adjusting knob must be turned all the way clockwise to close the diversion path and prevent water leaking from the softener valve inlet of the bypass.

CHECKING THE SALT STORAGE LEVEL and REFILL

Brine (salt dissolved in water) is needed for each and every recharge. The water for making brine is metered into the salt storage area by the water softening system valve and control. However, you must keep the tank supplied with salt.

ADDING SALT

Lift the salt hole cover and check the salt storage level frequently. If the water softener uses all the salt before you refill it, you will experience hard water. Until you have established a refilling routine, check the salt every two or three weeks. Always add if less than 1/4 full. Be sure the brinewell cover is on.

NOTE: if using potassium chloride (KCl), do not fill above level 4 on the brinewell decal.

NOTE: In humid areas, it is best to keep the salt storage level lower, and to refill more often to avoid salt “bridging”.

Recommended Salt: Nugget, pellet or coarse solar salts with less than 1% impurities.

Salt Not Recommended: Rock salt, high in impurities, block, granulated table, ice melting, ice cream making salts, etc.

CAUTION Water softening salt with iron removing additives: Some salts may have an additive to help the water softening system handle iron in the water supply. Although this additive may help to keep the water softening system resin clean, it may also release corrosive fumes that weaken and shorten the life of some water softening system parts.

CLEANING IRON OUT OF THE WATER SOFTENING SYSTEM

Your water softening system takes hardness minerals (calcium and magnesium) out of the water. Also, it can control some (see the Specification Guidelines section) “clear water” iron. With clear water iron, water from a faucet is clear when first put into a glass. After 15 to 30 minutes, the water begins to cloud or turn rust colored. A water softening system will not remove any iron that makes the water cloudy or rusty as it comes from the faucet (called red water iron). To take red water iron out of water, or over the maximum of clear water iron, an iron filter or other equipment is needed.

GE Appliances recommends using Super Iron Out® to clean your resin bed if your iron content is high. Use Super Iron Out® with every 40lb. bag of salt as preventative maintenance against rust build up. Clean the bed at least every six months, or more often if iron appears in the soft water between cleanings.

IMPORTANT: It is important to mix the resin bed cleaner with water (following the manufacturer’s instructions), pour it into the brinewell (see Figure 9) and recharge the softener immediately. Do not pour the resin bed cleaner in with the salt, as it will not be as effective in cleaning the resin, and can cause damage to the softener if it is left in the brine tank for an extended period due to the corrosive gases that are formed.

CLEANING THE NOZZLE AND VENTURI ASSEMBLY

A clean nozzle and venturi is needed for the water softening system to work properly. This small unit makes the suction to move brine from the salt storage area to the resin tank during recharge. If it becomes plugged with sand, dirt, etc., the water softening system will not work and you will get hard water.

To get to the nozzle and venturi, remove the water softening system top cover. Be sure the water softening system is in service cycle (no water pressure at nozzle and venturi). Then, while holding the nozzle and venturi housing with one hand, remove the cap. Lift out the screen support and screen, then the nozzle and venturi. Wash and rinse the parts in warm water until clean. If needed, use a small brush to remove iron or dirt. Also check and clean the gasket.

NOTE: Some models have a small flow plug located in the nozzle and venturi, and/or a small cone shaped screen in the housing. Be sure to check and clean these parts, if your model is so equipped.

Carefully replace all parts in the correct order. Lightly lubricate the o-ring seal with clean silicone grease or petroleum jelly and place in position. Install and tighten the cap, by hand only. Do not overtighten the cap.

BREAKING A SALT BRIDGE

Sometimes, a hard crust or salt bridge forms in the salt storage area. It is usually caused by high humidity or the wrong kind of salt. When the salt bridges, an empty space forms between the water and salt. Then salt will not dissolve in the water to make brine.

If the brine tank is full of salt, it is hard to tell if you have a salt bridge. Salt is loose on top, but the bridge is under it. The following is the best way to check for a salt bridge.

Salt should be loose all the way to the bottom of the tank. Take a broom handle or like tool, and carefully push it down into the salt, working it up and down. If the tool strikes a hard object (be sure it's not the bottom or sides of the tank), it's most likely a salt bridge. Carefully break the bridge with the tool. Do not pound on the walls of the tank. To help dissolve the salt bridge pour one gallon of warm water (not hot) into the tank. If the wrong kind of salt made the bridge, take it out. Then fill the tank with nugget or pellet salt only. In humid areas, it is best to fill with less salt, more often to prevent a salt bridge from forming.

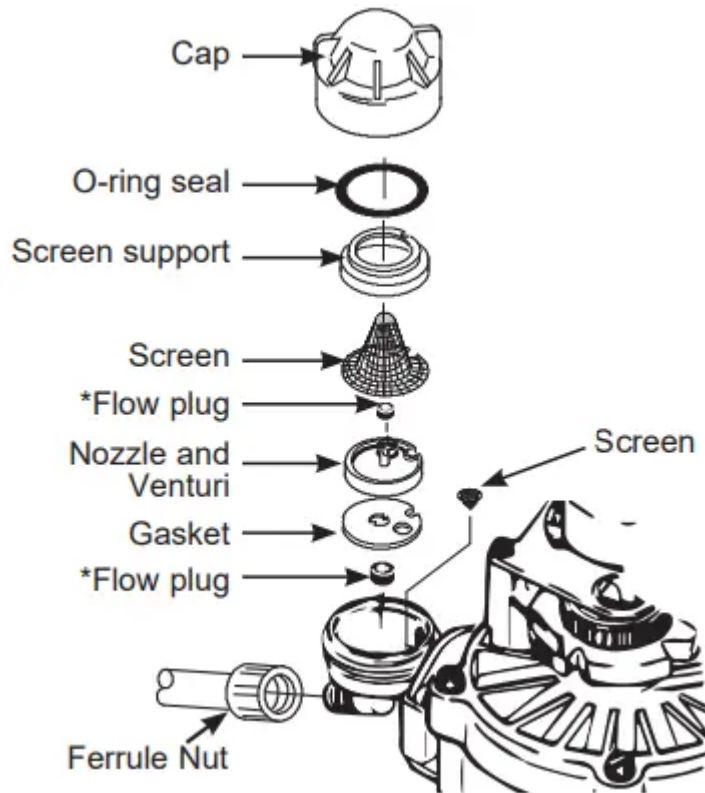

IMPORTANT: Be sure small holes in the gasket are centered directly over the small holes in the nozzle and venturi housing.

* Install with numbered side up, concave side down.

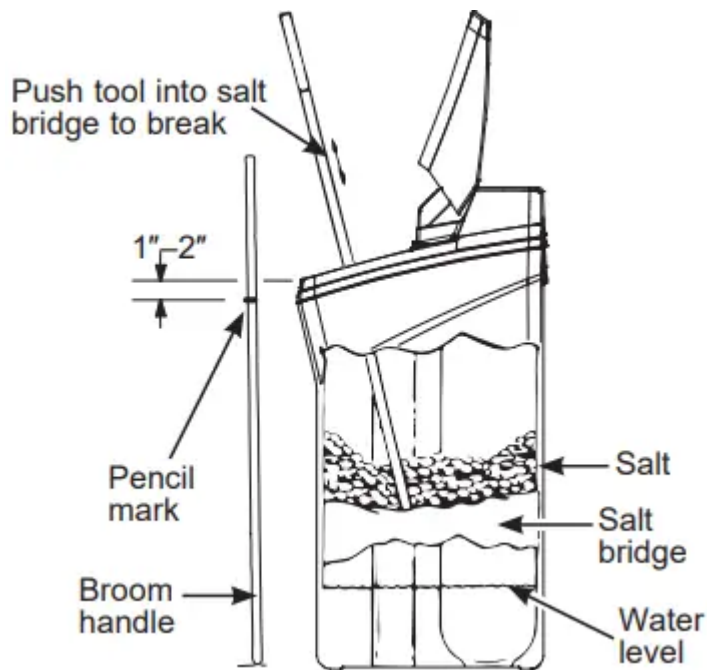

Before you call for service

Troubleshooting Tips

Save time and money! Review the chart on this page first and you may not need to call for service.

NO SOFT WATER – Most Common Problems:

Check the following before calling for service:

- Not enough salt—should be at least 1/3 full.
- Bypass valve in “Bypass” position—handle should be in the “OUT” (service) position.
- Hardness setting too low. Check hardness setting and adjust. Verify hardness of supply water—from local water company, water test or call the GE Appliances Answer Center (800-952-5039 in US).
- Salt Bridge—salt solidifies above water level so that brine water is not in contact with salt. See the Breaking a Salt Bridge section.

Problem	Possible Cause	What to do
No soft water	<p>Faucet or fixture where sample was taken not plumbed to soft water.</p> <p>NOTE: Be sure sample is from a faucet that does not mix soft and hard water. For example, a single lever kitchen faucet, if the cold side is plumbed to hard water</p>	<ul style="list-style-type: none"> • To conserve salt, the installer may have isolated some fixtures (outside faucets, toilets, etc.) from soft water. From the outlet of the water softening system, trace the water flow path in the house plumbing. If soft water is not directed to a faucet or fixture where wanted, consult a plumber.
	<p>No salt in the brine tank or salt bridged</p>	<ul style="list-style-type: none"> • Check for a salt bridge or, if the tank is empty, refill with recommended salt. Press (for 3 seconds) the RECHARGE button to start an immediate recharge and restore soft water supply.
	<p>External power supply unplugged at wall outlet or power cable to softener not connected. Fuse blown or circuit breaker popped on circuit to electrical outlet. Electrical outlet on a circuit that can continuously be switched off</p>	<ul style="list-style-type: none"> • Check for a loss of electrical power to the water softening system, due to any of these conditions and correct as needed. With the power supply restored, observe the faceplate time display and read Programming the Control section. NOTE: the electrical outlet for the softener should be live so it cannot be accidentally switched off.
	<p>Manual bypass valve in bypass position</p>	<ul style="list-style-type: none"> • Be sure the bypass valve stem is positioned properly, with the handle in the OUT position.
	<p>Blending valve in open position</p>	<ul style="list-style-type: none"> • Turn blending valve clockwise to closed position.
	<p>Valve drain hose pinched, plugged, elevated too high or otherwise restricted</p>	<ul style="list-style-type: none"> • Any restriction in the drain hose may prevent proper operation of the nozzle and venturi and reduce or prevent brine draw during recharge.
	<p>Nozzle and venturi dirty, incorrectly assembled or damaged</p>	<ul style="list-style-type: none"> • Refer to Cleaning the Nozzle and Venturi Assembly instructions. With water pressure to the water softening system off, take the nozzle assembly



		<p>apart. Inspect, clean and replace as needed. Any foreign particle(s), scratches, nicks, etc. in the passages can prevent operation. Be sure holes in the gasket are centered over holes in the housing.</p>
--	--	--



Problem	Possible Cause	What to do
Water hard sometimes	Using hot water while the water softening system is regenerating	<ul style="list-style-type: none"> • Avoid using hot water during water softening system recharge because the water heater will refill with hard water. See Automatic Hard Water Bypass During Recharge section.
	Control HARDNESS number setting too low	<ul style="list-style-type: none"> • Press MODE/SET button until arrow points to HARDNESS. Be sure the number shown is the same as the actual grains per gallon hardness of your water supply. See Programming the Control section if a change in setting is needed.
	Grains of hardness in your water supply have increased	<ul style="list-style-type: none"> • Water hardness can change over time, especially in well water. To check, have the water tested by a water analysis laboratory or call your local water department. Adjust the Hardness number setting as needed.
Water feels slippery after installation of water softener	Absence of hardness minerals	<ul style="list-style-type: none"> • This is normal. Hardness in water gives it the abrasive feel you may have been accustomed to. The slippery feel is the clean feel of soft water. • See the <i>Adjusting your Water Hardness</i> section.
Water Softener not using any salt	Water softening system is a “demand” unit	<ul style="list-style-type: none"> • Does not use much salt to regenerate - very efficient.
	Possible salt bridge	<ul style="list-style-type: none"> • See the <i>Breaking a Salt Bridge</i> section.
	Possible plugged nozzle and venturi	<ul style="list-style-type: none"> • See the <i>Cleaning the Nozzle and Venturi Assembly</i> section.

Water is blue color after water softener was installed	Acidic water in copper plumbing	<ul style="list-style-type: none"> • Have the water tested at once.
Water softener not regenerating	Meter turbine stuck	<ul style="list-style-type: none"> • See the Manually Initiated Electronics Diagnostics section for troubleshooting procedures. • Call for service.
	Sensor wire not plugged into the control	<ul style="list-style-type: none"> • See the Manually Initiated Electronics Diagnostics section for troubleshooting procedures. • Call for service.
	No power to unit	<ul style="list-style-type: none"> • Check the circuit breaker or fuses.
	Mechanical defect	<ul style="list-style-type: none"> • Call for service.
Cloudiness on glassware (automatic dishwashers)	Combination of soft water and too much detergent	<ul style="list-style-type: none"> • This is called etching and is permanent. To prevent this from happening, use less detergent if you have soft water. Wash glassware in the shortest cycle that will get them clean.

Problem	Possible Cause	What to do
Excessive/ high level of water in brine tank	Valve drain hose pinched, plugged, elevated too high or otherwise restricted	<ul style="list-style-type: none"> • A restriction in this drain hose may prevent proper operation of the nozzle and venturi and reduce or prevent brine draw during recharge.
	Drain lines connected together	<ul style="list-style-type: none"> • Separate drain lines.
	Nozzle and venturi dirty, incorrectly assembled or damaged.	<ul style="list-style-type: none"> • Refer to Cleaning the Nozzle and Venturi Assembly instructions. With water pressure to the water softening system off, take the nozzle assembly apart. Inspect, clean and replace as needed. Any foreign particle(s), scratches, nicks, etc. in the passages can prevent operation. Be sure holes in the gasket are centered over holes in the housing
Salty tasting or brown/ yellow colored water after installation	Unit not sanitized	<ul style="list-style-type: none"> • Complete Sanitization Procedures. • At completion of recharge cycle (approx. 2 hours), run water from faucets to purge the salty water.
	Low water pressure	<p>Check pressure:</p> <ul style="list-style-type: none"> • Drain height 8' or less, pressure should be minimum 20 psi. • Drain height above 8', pressure should be minimum 50 psi.
	Restricted drain hose	<ul style="list-style-type: none"> • Clean and reconnect hose. • Check for kinks in drain line
Brown/yellow colored water	Unit was idle for a period of time	<ul style="list-style-type: none"> • Complete the Sanitization Procedures.

Resin beads showing up in drinking water	Cracked distributor or unit plumbed backwards	<ul style="list-style-type: none"> • Check softener “IN & OUT” plumbing is correct. • Call for service.
Sounds you might hear	Running water from the unit into a drain during recharge	<ul style="list-style-type: none"> • This is normal.
Water has air bubbles and is cloudy	Air in system after installation	<ul style="list-style-type: none"> • Will go away after it runs for a while.
Blue light Flashing		
When power applied to the system	Control needs to be programmed (a power outage may have occurred)	<ul style="list-style-type: none"> • See the Programming the Control section.
If “DAYS TO EMPTY” is flashing	Low salt level, less than 15 days	<ul style="list-style-type: none"> • Fill with salt. • Reset salt level.

Problem	Possible Cause	What to do
Error Codes 1,3,4,5 on Control	Wiring may have worked loose in the control	<ul style="list-style-type: none"> • Unplug external power supply. • Remove control cover, release clips on side. • Check for loose/incorrect wiring connections to electronic board or switch. Reconnect as required. • Reassemble control cover. • Plug in Transformer. • Wait 8 minutes for Error Code to reappear. • If error Code reappears, call for service.
Error Codes 6,7,8 on Control	Issue with Water Shutoff valve	<ul style="list-style-type: none"> • Unplug external power supply. • Replace the water Shutoff valve. • Check for loose/incorrect wiring connections to electronic board. Reconnect as required. • Reassemble control cover. • Plug in Transformer. <p>- When the Error 6,7 or 8 is displayed, press and hold the Recharge button for 5 seconds.</p> <ul style="list-style-type: none"> • Wait 2 minutes for Error Code to reappear. • If error Code reappears, call for service.
If "Err" in display	Electrical problem with system	<ul style="list-style-type: none"> • Call for service.

Advanced troubleshooting for service

AUTOMATIC ELECTRONIC DIAGNOSTICS

This water softener has a self-diagnostic function for the electrical system (except into power and/or water meter). The water softener monitors electronic components and circuits for correct operation. If a malfunction occurs, an error code appears in the display.



Figure 18

While an error code appears in the display, all buttons are inoperable except the MODE/SET button. MODE/SET remains operational so the service person can perform the Manual Advanced Diagnostics, see below, to further isolate the problem.

Procedure for removing error code from display:

1. Unplug transformer from electrical outlet.
2. Correct problem.
3. Plug in transformer.
4. Wait 8 minutes. The error code will return if the problem was not corrected.

MANUAL INITIATED ELECTRONIC DIAGNOSTICS

Use the following procedures to advance the water softener through the regeneration cycles to check operation.

Lift off the Salt Hole Cover, remove the top cover by unlocking the tabs in the back and rocking forward, to observe cam and switch operation during valve rotation.

1. Press and hold MODE/SET for 3 seconds until the Set low salt alarm display appears, next press the MODE/SET button two additional times until "000" shows in the display, then release, see Figure 15.
2. The 3 digits indicated water meter operation as follows: If you don't get a reading on the display, with faucet open, pull the sensor from the valve outlet port. Pass a small magnet back and forth in front of the sensor. You should get a reading in the display. If you get a reading, shut off water supply, unhook the in and out plumbing and check the turbine for binding.

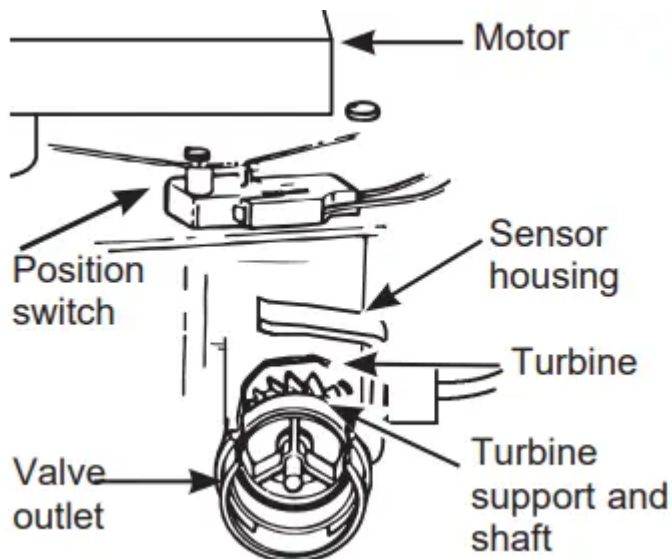

3. Symbols in the display indicate POSITION switch operation, (see Figure 19).

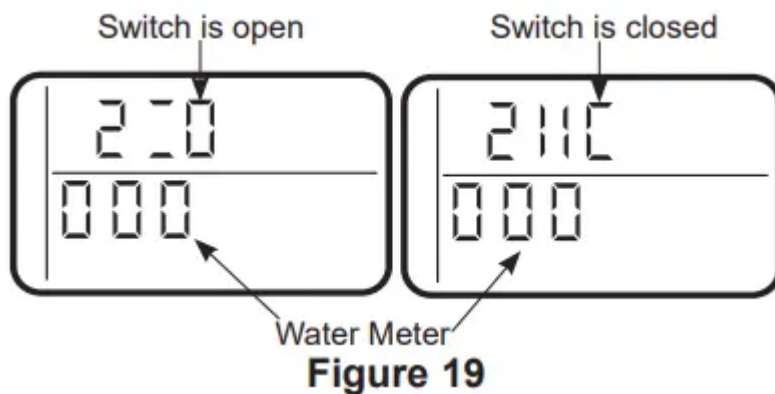

4. Use RECHARGE button to manually advance the valve into each cycle and check correct switch operation. NOTE: Be sure water is in contact with salt, and not separated by a salt bridge (see Breaking a Salt Bridge section).

5. While in this diagnostic screen, the following information is available and may be beneficial for various reasons. This information is retained by the computer from the first time electrical power is applied to the electronic controller.

- a. Press the UP ▲ button to display the number of days this electronic control has had electrical power applied.
- b. Press the DOWN ▼ button to display the number of regenerations initiated by the electronic control since the code number was entered.

6. Press and hold the MODE/SET button until the mode code (H40 for GXSHC40N) shows in the display (see Figure 20). This code identifies the softener mode. If an incorrect model code is displayed, the softener will operate on incorrect configurations data.

7. To change the code number, press the ▲ UP or DOWN ▼ button until the correct code shows.



Figure 20

8. To return to the present time display, press the MODE/SET button.

9. Press the MODE/SET button to return to the present time display. If the code was changed, make all the timer setting.

NOTE: If the control is left in a diagnostic display or a flashing display when setting times or hardness, present time automatically returns if a button is not pressed within four minutes.

Service: Manually Advance Recharge Check

NOTE: The control display must show a steady time (not flashing).

1. Press the RECHARGE button and hold in for three seconds. RECHARGE begins to flash as the water softening system enters the fill cycle of recharge. Remove the brinewell cover and, using a flashlight, observe fill water entering the brine tank. If water does not enter the tank, look for an obstructed nozzle, venturi, fill flow plug or brine tubing. See Care and Cleaning of the Water Softener System section.

2. After observing fill, press the RECHARGE button to move the water softening system into brining. A slow flow of water to the drain will begin. Verify brine draw from the brine tank by shining a flashlight into the brinewell and observing a noticeable drop in the liquid level over an extended period of time (is to 20 minutes).

NOTE: Be sure a salt bridge is not preventing water from contacting salt. See Care and cleaning of the water softening system section.

If the water softening system does not draw brine, check:

- nozzle and/or venturi dirty or defective.
- defective nozzle and venturi seal.
- nozzle and venturi not seated properly on gasket.
- other inner valve defect (rotor seal, rotor and disc, wave washer, etc.).
- restricted drain (check drain fitting and hose).

NOTE: If water system pressure is low, an elevated drain hose may cause back pressure, stopping brine draw.

3. Again, press the RECHARGE button to move the water softening system into backwash. Look for a fast flow of water from the drain hose. A slow flow indicates a plugged top distributor, backwash flow plug or drain hose.

4. Press the RECHARGE button to move the water softening system into fast rinse. Again look for a fast drain flow. Allow the water softening system to rinse for a few minutes to flush out any brine that may remain in the resin tank from the brining cycle test.
5. To return the water softening system to service, press the RECHARGE button.

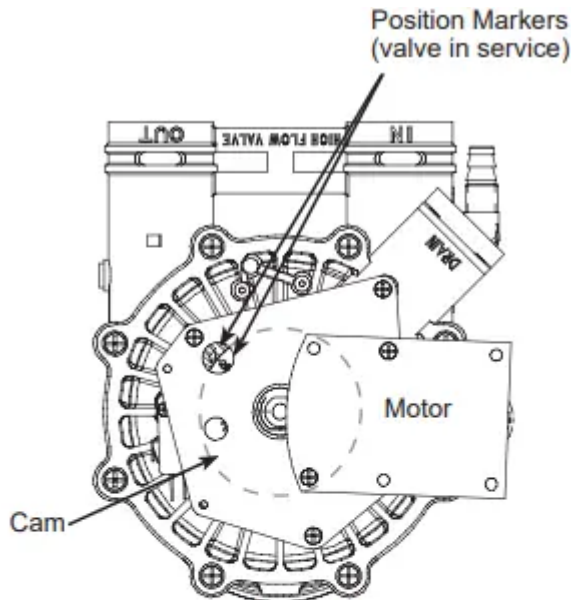

Figure 21

Valve Positions:

Position	Function
S	Service
F	Fill
BR	Brine Fill
BW	Back Wash
R	Rinse

Warning

This content is compiled from multiple sources and is provided for reference purposes only. It may not be complete or fully applicable to all situations. If you are unable to resolve your issue, please contact the product manufacturer or an authorized service provider for official support.

