















USER MANUAL TELEVISION



Remote Control Functions



-  (**MUTE** button) Turns the volume off or on.
-  (**POWER** button) Turns the TV on or standby.
- 0-9** (Numeric buttons) Enters channel numbers.
-  Goes to the **Golive** Homepage.
- LIST** Displays the channel list menu.
-  +/- (VOLUME UP/DOWN) Increases or decreases the TV's volume.
-  (**HOME** button) Goes to the smart TV homepage.
- P</>** (CHANNEL UP/DOWN) Scans up or down through the current channel list.
-  Displays the status information of the current program or source.
-  (**SETTING** button) Brings up the main menu or press to return to the previous menu.
-  (**OPTION** button) Shortcut to **Freeze**, **PVR Disk** (only available in DTV mode), **PVR** (only available in DTV mode), **Football Mode**, **HDMI 2.0** (only available in HDMI mode), **Channel List** (only available in TV mode), and **Settings**.
-  (Up, down, left and right direction buttons) Highlights different items in the menu system and adjusts the menu controls.
Note: Press  /  to select the desired screen format.
- OK** When in the menu system, confirms your selection or changes settings.
-  To enter the source selection interface.
-  (**BACK** button) In menu mode, goes back to the previous menu or interface; in TV mode, goes back to the last viewed channel.
- GUIDE** Toggles the Electronic Programme Guide between on and off.
Note: *This function is only available in DTV mode.*
- EXIT** Exits the menu system.
-  **LANG** Press it to switch the sound track.
- TEXT** Toggles teletext on or off.
Note: *This function is not available for some models.*
- SUBT.** Selects a subtitle language available for selected digital TV programme.



Colored buttons (RED/GREEN/YELLOW/BLUE) Performs the corresponding function indicated at the bottom of the screen.

• **REC** Press to start PVR directly.

NETFLIX Goes to the Netflix homepage.

Note: This button may be  for some models and goes to the Golive homepage.

■ (Stop) Stops viewing.

▶ (Play) Starts Viewing.

|| (Pause) Pause Viewing.

◀◀ Searches backward.

▶▶ Searches forward.

Note: The above *five* buttons can be used for playing music, pictures and videos in the USB menu.

Connections and Setup

Switching on

Follow the instructions on this page on how to switch on your TV set and the remote control before going on to following pages describing how to use the channel set-up procedure.

1. Insert two AAA batteries in the remote control

2. Connect the power cable FIRST to the television, THEN to a mains socket. (Note: If the power cable is connected to the television, please only connect the power cable to the mains socket.)

Your TV set should only be connected to an AC supply. It must not be connected to a DC supply. If the plug is detached from the cable, do not, under any circumstances, connect it to a mains socket, as there is a risk of electric shock.

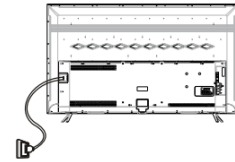

3. Connect an outside aerial to the ANTENNA IN socket at the back of the TV set

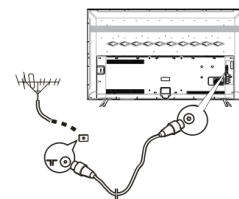

4. When powered on, the TV will be turned on directly or be in standby mode

If the power indicator lights up, the TV set is in standby mode. Press the  button on the remote control or on the TV set to turn on the TV.

Switching off

- To put the TV set into standby mode, press the  button on the remote control. The TV set remains powered up, but with low energy consumption.
- To switch off the TV set, unplug the mains socket from the mains outlet.

Choose Your Connections

There are several ways to connect signal sources, such as BD player, DVD players and set-top boxes, to your TV.

Note: No cables are supplied with this TV. Please purchase the necessary cables for connection. A high-speed HDMI cable is recommended for better compatibility.

Input	Signal Compatibility
Antenna	480i, 480p, 720p, 1080i (PAL, and DVB-T formats)
Composite Video	480i, 567i
HDMI	480i, 480p, 720p/60Hz, 1080i/60Hz, 1080p/60Hz, 3840×2160p (for 4K TV)

Network Connection

To access the Internet, you must subscribe to high speed broadband Internet service with your Internet service provider (ISP).

Your TV can be connected to your home network in two ways:

- Wired, using the RJ45 (LAN) connector on the back panel.
- Wireless, using the internal wireless and your home wireless network

Note: Instructions below are just the usual ways to connect your TV to the wired or wireless network. The connection method may be different depending on your actual network configuration. If you have any questions about your home network, please refer to your ISP.

Connecting to a wired network

To connect to a wired network:

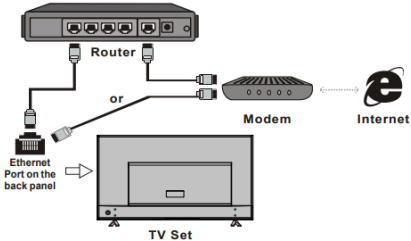
<ol style="list-style-type: none">1. Ensure you have:<ul style="list-style-type: none">• An Ethernet cable long enough to reach your TV• A router or modem with an available Ethernet port• A high-speed Internet connection• An Ethernet (LAN) port on the back of the TV2. Connect your Ethernet cable to the router and to the Ethernet port on the back of the TV.3. Use the Network menu to configure the TV.	 <p>The diagram illustrates the wired connection setup. At the top, a 'Router' is connected to an 'Internet' service (represented by a globe icon). Below the router, a 'Modem' is also connected to the 'Internet'. An Ethernet cable is shown connecting the Router to the TV Set. Another Ethernet cable is shown connecting the Modem to the TV Set. The TV Set has an 'Ethernet Port on the back panel' indicated by an arrow. The word 'or' is placed between the Router and Modem connections, indicating either can be used.</p>
---	---

Connecting to a wireless network

To connect to a wireless network:

<ol style="list-style-type: none">1. Ensure you have:<ul style="list-style-type: none">• A router broadcasting a high-speed wireless signal• A high-speed Internet connection2. Use the Network menu to configure the TV.	 <p>A small icon showing a wireless router and a TV set, representing the wireless connection setup.</p>
---	---

Initial Setup

Select Language

Press ▲/▼ to select your preferred language for the menu system, and then press OK to enter the next step.

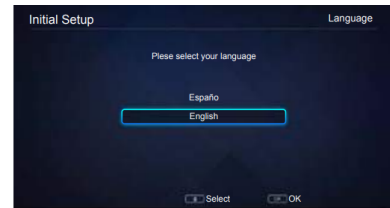

Select Location

Press ▲/▼ to select your location: Home or Shop and then press OK to enter the next step.

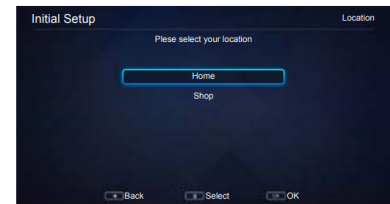

Agree to Disclaimer

Press ▲/▼ to select I agree and then press OK to enter the next step.

Set up Network

Press ▲/▼ to select Setup and press OK to configure the network. For detail, refer to Network Settings on page 17. You can also select Skip to skip this step and perform network settings later.

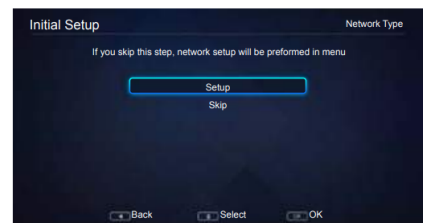

Timezone

Press ▲/▼ to select Your Time Zone and press OK to enter the next step.

Scan for Channels

Press ▲/▼ to select Scan and press OK to start the search automatically. All available TV channels are stored. This operation takes a few minutes. The display shows the progress of the search and the number of programs found. You can also select Skip to skip this step and perform channel scan later.

Note: To prevent the channel setup process from being interrupted, wait for the message indicating that the setup is complete.

During the setup, user can follow the hint available at the bottom of the screen to return to the last step by pressing back button or EXIT to interrupt the search halfway.

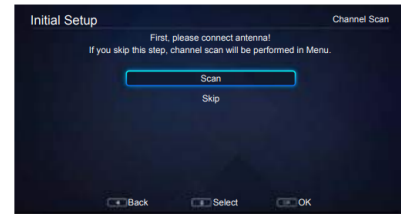

Initial Setup Complete

After initial setup is complete, press OK to exit. The channels are arranged in a preset order. If you wish to skip channels, or organize channels, press Setting button to display the main menu, select Channel > Channel Edit and press OK to enter.

System Settings Menu

Using Menu System

This section explores the system settings menu of your TV. Each menu is outlined and detailed to help you get the most from your TV. Please note that some function might be unavailable in certain input source. To access the menu system:

1. Press setting button on remote control to display the main menu.
2. Press ◀/▶ to select CHANNEL, PICTURE, SOUND TIME, OPTION and LOCK.
3. In the submenu, press ▲/▼ to select menu options, press OK to open the corresponding submenu or activate a setting.
4. To return the previous menu, press BACK. To close the menu, press EXIT.

Note: Figures and illustrations in this User Manual are provided for reference only and may differ from actual product appearance. And for some models, certain options are not available.

Channel



Press setting button and select Channel. The Channel options are as follows:

Auto Scan

1. Scan all Channels
2. Digital channel only
3. Analog channel only

Select prefer option and press OK to scan. Press setting button, BACK or EXIT button to quit scanning

DTV Manual Tuning

This allows you scan with a range of channels.

Note: This function is only for digital channels.

1. Select Channel > DTV Manual Tuning, and then press OK to enter.
2. Press ◀ / ▶ to select channel number.
3. Press OK to start channel scanning.
4. Press SETTING to return or EXIT to close the menu.

ATV Manual Tuning

This allows you scan with a rang of channels. Operations are similar to that of DTV Manual Search.

Note: This function is only for analog channels.

Channel Edit

1. Select Channel > Channel Edit and press OK to display Channel Edit menu.
2. Press ▲/▼ to select the channel as your desired, then press red button on the remote control to pop up your favorite channel list. (you have to set favorite channels by pressing red button.)
3. Press setting button to return or EXIT to close the menu.

PICTURE

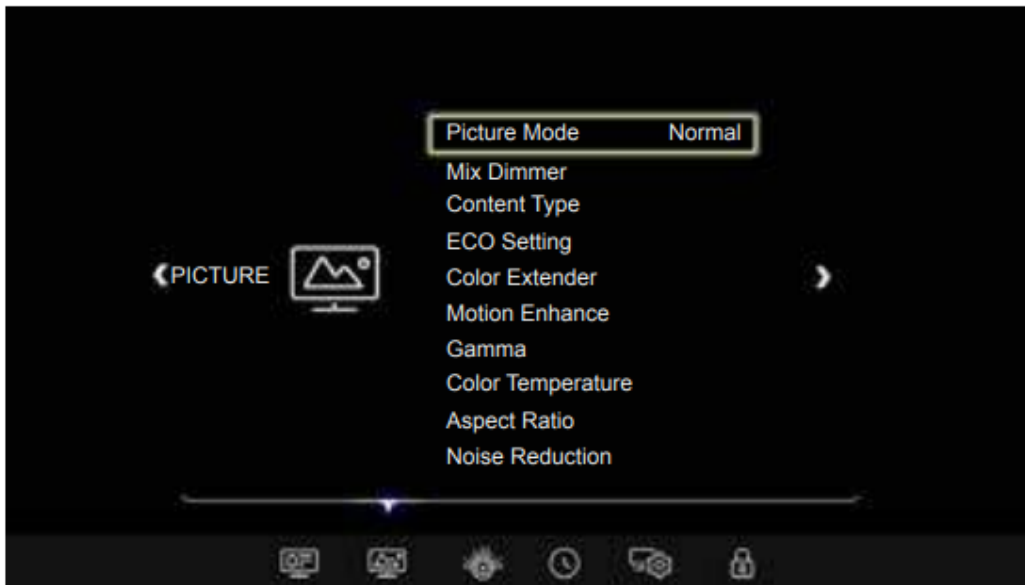

Press setting button and select Picture. The Picture options are as follows:

Note: Some options may be not available for certain signal sources.

Picture Mode

Press OK to enter, and then press ◀/▶ to select a picture mode: Dynamic, Normal, Natural or User.

Mix Dimmer

Adjusts the backlight in a higher frequency for a more comfortable watching. Press OK to select On or Off.

Content Type

Press OK to enter, and then press ◀/▶ to select a content type according to the content connected to the HDMI socket: PC, Video, or Game.

Note: This option is only available in HDMI mode.

ECO Setting

Automatically adjusts the back light, depending on room lighting. Press OK to select On or Off.

Color Extender

Press OK to enter, and then press ▲/▼ to select Off, Low, High, or xvYCC.

Note: For some models, the options are Off, On, xvYCC.

Motion Enhance

Motion Enhance: Press OK to enter. Press ▲/▼ select Off, Low, Middle, or High.

Gamma

Sets the shape of the Gamma curve. Use lower Gamma values for bright ambient lighting, and higher values when it is dark.

Color Temperature

Adjusts the color temperature of the picture. Press OK to enter. Press ▲/▼ to select the color settings: Cold for a more blue palette of picture colors; medium and Warm for a more red palette of picture colors.

Note: For some models, the Color Temperature option is not available.

Aspect Ratio

Press OK to enter. Press ▲/▼ select the mode to display the picture: Auto, 4:3, 16:9, Just Scan.

Noise Reduction

Improves the quality of the picture in the case of poor reception. Press OK to enter. Press ▲/▼ to select Off, Low, Middle, High or Auto.

Dynamic Contrast

Press OK to select On or Off.

SOUND

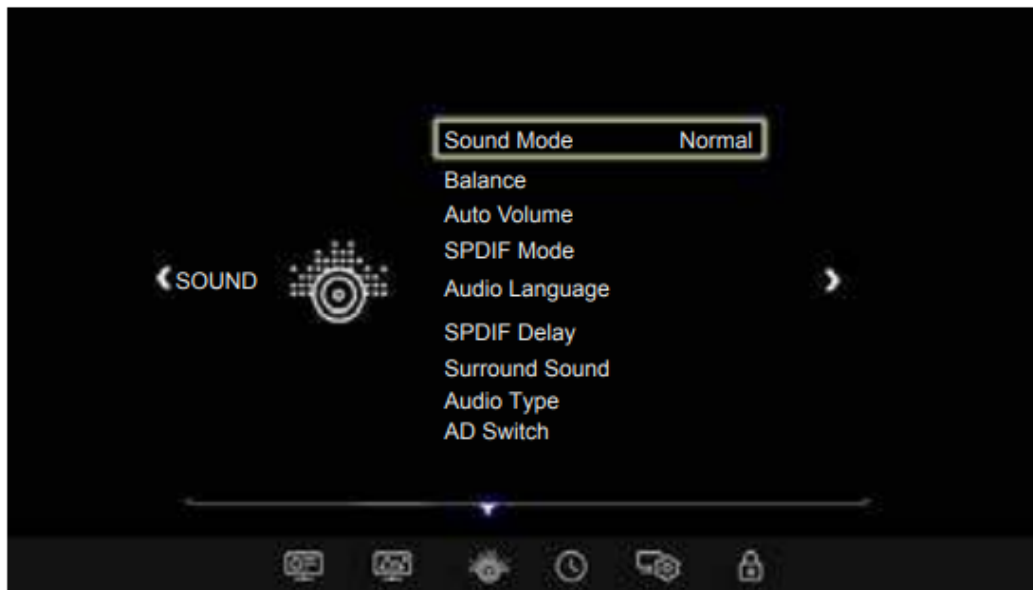

Press setting button and select Sound, then press OK to confirm. The Sound options are as follows:

Sound Mode

Press OK to toggle among Normal, Music, Movie, News and User

Balance

Press OK to balance the sound between the left and right speakers from 0 to 100.

Auto Volume

To keep the same sound level for all channels, set Auto Volume to On .

SPDIF Mode

Press OK to toggle between Auto and PCM

Audio Language

Choose from the list of languages available for the program you're watching. The language chosen becomes your preferred language for all digital channels until you turn the TV off. If the language chosen is not being broadcasted with a program, the TV plays the default language for the program.

Note: The [Default Audio Language] option is only available for digital channels.

SPDIF Delay

This option is used to synchronize the sound with the picture. If the sound is slower/quicker than the action of the picture, you can press ◀/▶ to turn down/up the numerical value.

Surround Sound

Press OK to enter, and then press ▲/▼ to select the simulated surround sound feature to be Off or Surround.

Audio Type

Press OK to select the sound type mode to be Visual Impaired or Normal.

Note: This option is only available for digital channels.

AD Switch

Press OK to enter, and then press ◀/▶ to select the audio description (AD) to be On or Off. When set to On, you can press ▲/▼ to select AD Volume, and then press ◀/▶ to adjust the volume for audio description.

Note: This option is only available when Audio Type is set to Visual Impaired.

TIME

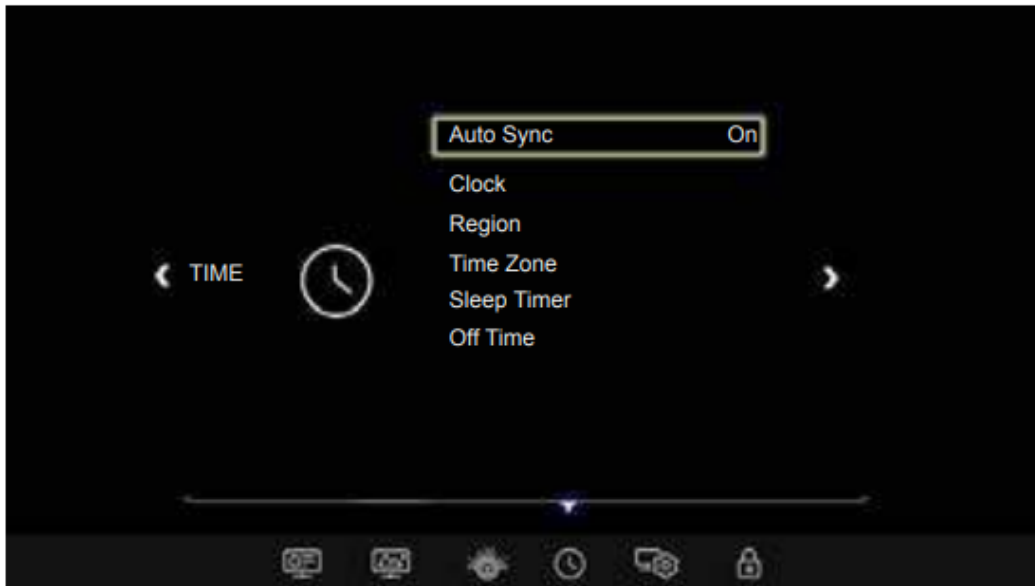

Press setting button and select TIME. The options are as follows:

Note: Time Zone is available only when Auto Synchronization (submenu of Clock) is set to ON.

Auto Sync

Press OK to toggle between On and Off.

Clock

(set Auto Sync. off) Press OK to enter and press ▲/▼ to select Date, Month, Year, Hour or Minute, then press ◀/▶ to change numbers.

Region

(Only in DTV) Press OK to enter and press ▲/▼ to select your region.

Time Zone

Press OK to enter and press ▲/▼ to select the local zone.

Sleep Timer

Press OK to enter and press ▲/▼ to select: Off, 10Min, 20Min, 30Min, 60Mi, 90Min, 120Min, 180Min and 240Min.

Off Time

Press OK to enter. Press ◀/▶ to select Once, Daily or Off. Press ▲/▼ to select Hour and Minute. Press ◀/▶ to change numbers.

Problems & Solutions

Note: Problems & solutions 1 to 2 are for the TV models which have network functions, so users of non-connected TV models can disregard them.

1. Fail to link to the network.

- Check if your TV is connected with the network;
- Reboot your TV;
- Consult your internet service provider, to confirm if access of your router is supported. Refer to the operation manual of your router, and activate its DHCP function after linking the network to your TV.
- Make sure your TV is connected to a router, and make sure your router is powered on. Check that your router/modem has an internet connection, and that your Ethernet cables/ wireless connection is OK. Test your connection with a computer to make sure it is OK. Should the problem persist, contact customer service.

2. How to use the wireless USB adapter?

- When connecting to wireless network, inserted the wireless USB adapter into your TV's USB port, it will work together with your wireless router. For details, please refer to Network Connection.

3. The video could not be played smoothly.

- Videos from your USB flash drive --- It may result from data transmission, or its code flow is far beyond the supported formats of this TV set.
- Videos downloaded from internet, or online videos.
 - a. It may be caused by the lower bandwidth of your network. A high network speed is required to handle online videos.
 - b. Peak internet usage times may affect the bandwidth.

c. Check if any other computers on the same network are also operating, as they may be using up bandwidth. Especially if they are downloading or displaying on-line videos.

d. The video may not be smooth itself, it is not the problem of your TV or network. may consider some content inappropriate for unsupervised viewing by children aged 8-13. Violence Guidelines: Depictions of conflict and/or aggression will be limited and moderate; may include physical, fantasy, or supernatural violence. Other Content Guidelines: May contain infrequent mild profanity, or mildly suggestive language. Could also contain brief scenes of nudity.

4. When two mobile hard disks are connected with the TV at the same time, they will not be recognized some times.

- All mobile hard disks consume a lot of power, which may result in power supply problems. We recommend inserting only one hard disk, or a low power consumption mobile hard disk.

5. The video from a mobile hard disk (USB) is playing with no sound.

- The audio format of the video in your mobile hard disk is not supported by the TV player.

6. Some videos fail to play.

- The formats of the videos may not be supported by the TV, especially videos shot by certain kinds of cameras, generally with their private protocol of formats, which are not compatible with your TV.

7. Video stops playing midway.

- Mistakes may occur when videos are copied or compressed, so they may automatically stop playing during playback.

8. What should I pay attention to, when I do SW updating?

- No power cuts when SW updating;
- Avoid any operations with your remote control when SW updating;
- Depending on your internet connection speed, the software updating process may take some time.

9. There are no distinct changes of TV interface after SW updating.

- Under certain conditions, SW updating may not only update or add new functions but also improve the performance of the TV set, without distinct changes of interface. Also, there may be no changes to the user interface at all.

10. What should I do when SW updating process stops due to a sudden power-off?

- If you do SW updating by USB, do not pluck the USB from your TV, and restart your TV to continue SW updating; If you do SW updating by Network, also restart your TV and check if it is well functioned.



11. With a USB device being inserted into the TV in advance, I am prompted that no USB devices are detected after I access Media, why?

- There may be something wrong with your mobile hard disk(s), damaged or with low voltage. You could increase power supply by inserting the two plugs on one end on the USB wire into TV's USB port simultaneously.

12. External device cannot be recognized.

- Some external devices (e.g. webcam, smart phone, tablet, game handle, and external wireless adapter) may not be compatible with the TV and cannot be supported for certain functions (nScreen, wireless display, gesture control, face recognition, if any). Please try a similar device. If it does not work, contact your local dealer.

Troubleshooting

Most problems you encounter with your TV can be corrected by consulting the following troubleshooting list.

No picture, no sound

1. Check if the fuse or circuit breaker is working.
2. Plug another electrical device into the outlet to make sure it is working or turned on.
3. Power plug is in a bad contact with the outlet.
4. Check the signal source.

No color

1. Change the color system.
2. Adjust the saturation.
3. Try another channel. Black-white program may be received.

Remote control does not work

1. Change the batteries.
2. Batteries are not installed correctly

No picture, normal sound

1. Adjust the brightness and contrast.
2. Broadcasting failure may happen.

Normal picture, no sound

1. Press the VOLUME UP button to increase volume.
2. Volume is set to mute, press the MUTE button to restore sound.

3. Change the sound system.
4. Broadcasting failure may happen.

Unorderly ripples on the picture

It is usually caused by local interference, such as cars, daylight lamps and hair driers. Adjust the antenna to minimize the interference.

Snowy dots and interference

If the antenna is located in the fringe area of a television signal where the signal is weak, the picture may be marred by dots. When the signal is extremely weak, it may be necessary to install a special antenna to improve the reception.

1. Adjust the position and orientation of the indoor/ outdoor antenna.
2. Check the connection of antenna.
3. Fine tune the channel.
4. Try another channel. Broadcasting failure may happen.

Ignition

Black spots or horizontal streaks appear, or the picture flutters or drifts. This is usually caused by interference from car ignition system, neon lamps, electric drills, or other electrical appliance.

Ghost

Ghosts are caused by the television signal following two paths. One is the direct path, the other is reflected from tall buildings, hills, or other objects. Changing the direction or position of the antenna may improve the reception.

Radio frequency interference

This interference produces moving ripples or diagonal streaks, and in some case, loss of contrast in the picture. Find out and remove the radio interference source.

* To bring you better visual experience, please remove all labels from TV front panel and screen before use.

Warning

This content is compiled from multiple sources and is provided for reference purposes only. It may not be complete or fully applicable to all situations. If you are unable to resolve your issue, please contact the product manufacturer or an authorized service provider for official support.