

TV components

Right side jacks

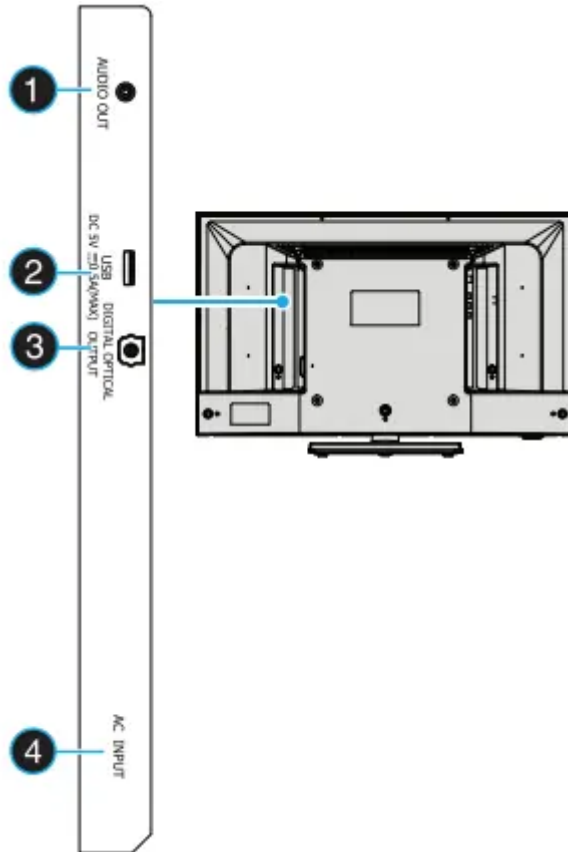

#	Item	Description
1	AUDIO OUT	Connect an analog sound bar, speaker system, or home theater system to this jack to listen to TV audio through external speakers. For more information, see Analog audio using the AUDIO OUT jack on page 30.
2	USB	Connect a USB flash drive to this jack to view compatible photos and video, listen to music files, or pause live TV. For more information, see Connecting a USB flash drive on page 26 and Pause live TV on page 7.
3	DIGITAL OPTICAL OUTPUT	Connect a digital sound bar, speaker system, or home theater system to this jack to listen to TV audio through external speakers. For more information, see Digital audio using the DIGITAL OPTICAL OUTPUT jack on page 28.
4	AC INPUT	Plug the power cord into this connection and into a power outlet.

Left side jacks



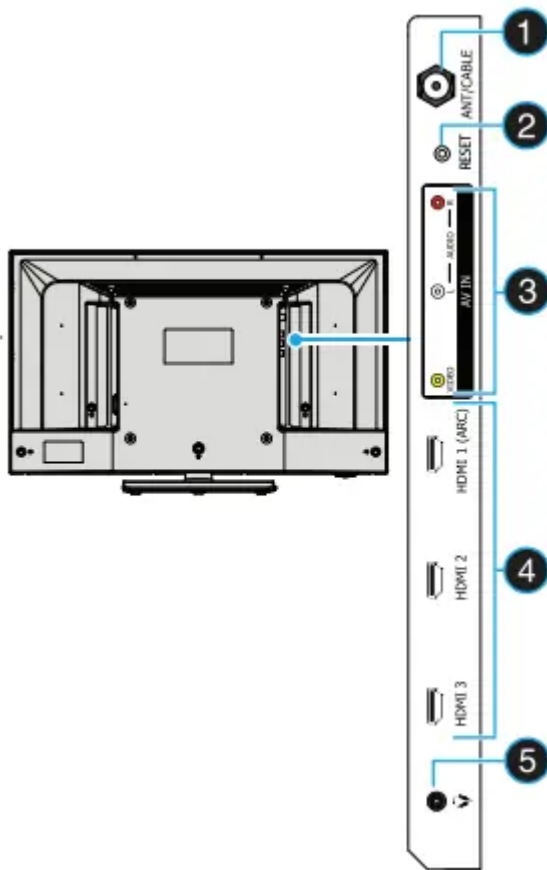





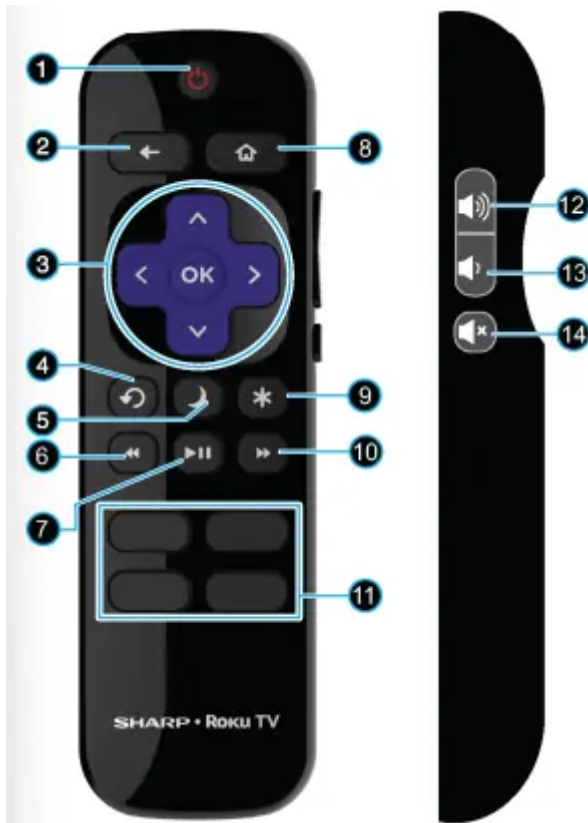

#	Item	Description
1	ANT/CABLE	Connect an antenna or cable TV to this jack. For more information, see Coaxial (good) on page 19 or Connecting an antenna or cable TV (no box) on page 20.
2	RESET	Press and hold reset for 15 seconds for factory reset.
3	VIDEO/ L and R AUDIO	Connect an AV device to these jacks. For more information, see AV (good) on page 18, 22, or 24.
4	HDMI 1 (ARC) HDMI 2 HDMI 3	Connect HDMI® devices to these jacks. For more information, see HDMI® (best) on pages 17, 21, or 23 or Connecting a computer on page 25. Connect an ARC-enabled home theater receiver to the HDMI 1 (ARC) jack. For more information, see Digital audio using the HDMI 1 (ARC) jack on page 29.
5	🔊 (headphones)	Connect headphones to this jack. See Connecting headphones on page 27.

Remote control



#	Button	Description
1	⏻ (power)	Turns your TV on or off.
2	← (back)	<p>The action depends on what you are doing with your TV:</p> <p>Menu—Goes back to the previous menu or screen.</p> <p>Home screen tile—Moves the highlight back to the Home menu option.</p> <p>Watching Antenna TV or a TV input—Returns to the screen from which the input was selected.</p> <p>Playing streaming content—Stops playing stream and returns to the previous menu or screen.</p> <p>Browsing streaming content—Goes to the previous level in the content tree.</p>

		<ul style="list-style-type: none"> ▲ / ▼—Moves the highlight up or down one item. ◀—Moves the highlight left, if a < hint appears. <ul style="list-style-type: none"> • When watching TV, displays your channel list. • When playing most streaming videos, skips backward in the video. ▶—Moves the highlight to the right, if a > hint appears. <ul style="list-style-type: none"> • When watching TV with the channel list displayed, dismisses the channel list. • When playing most streaming videos, skips forward in the video. OK—Selects the highlighted option. <ul style="list-style-type: none"> • When watching TV, displays information for the current TV program.
3	▲▼◀▶ and OK	
4	 (previous)	<p>Watching Antenna TV or cable (no set-top box)—Changes to the previous channel.</p> <p>Playing streaming content—Jumps back one position in the video.</p> <p>Menu—Backspaces one letter during menu entries, such as Search.</p>
5	 (sleep)	<p>First press displays a banner showing the remaining sleep time, if any, or Sleep timer is off. Subsequent presses cycle among the preset sleep time intervals: 30 minutes, 1 hour, 1.5 hours, 2 hours, and 3 hours. After it is set, the Sleep timer remains in effect regardless of what you are watching.</p>
6	 (rewind)	<p>When playing streaming video that supports this feature or broadcast TV if Live TV Pause is enabled, cycles through 1×, 2×, and 3× rewind speeds.</p> <p>When playing streaming audio, jumps to the previous track/selection.</p> <p>When any menu, tile, or channel in the channel list is highlighted, jumps up one page.</p> <p>When using a virtual keyboard, jumps to the character at the top of the current column.</p>
7	 (play/pause)	Pauses and plays streaming content.
8	 (home)	Immediately returns to the Home screen and stops playback if you are watching TV or streaming content.
9	* (options)	<p>Displays an <i>Options</i> menu, but only when the Options * hint in the upper right corner of the screen is not dimmed. The menu you see varies depending on what you are doing with your TV.</p> <p>Also, in most cases, pressing * while video is playing displays an <i>Options</i> menu over part of the screen where you can adjust various picture and sound settings.</p>
10	 (fast forward)	<p>When playing streaming video that supports this feature or broadcast TV if Live TV Pause is enabled, cycles through 1×, 2×, and 3× fast-forward speeds.</p> <p>When playing streaming audio, jumps to the next track/selection.</p> <p>When any menu, tile, or channel in the channel list is highlighted, jumps down one page.</p> <p>When using a virtual keyboard, jumps to the character at the bottom of the current column.</p>

11	Streaming Channels Shortcuts	<p>Dedicated buttons show the logo of a featured streaming content provider. Pressing a button turns your TV on (if your TV is not already on), and if your TV is operating and is connected to the internet, performs one of the following actions:</p> <ul style="list-style-type: none"> • Displays the streaming channel's main page if you have already added the channel to your Home screen. • Displays the streaming channel's sign-up page if you have not already added the channel so that you can agree to any terms and fees for the service.
12	🔊 (volume up)	<p>Turns the volume up one setting with each press. Press and hold to turn the volume up rapidly. A volume indicator shows the volume level while you are adjusting the volume and for a few seconds afterward.</p> <p>Note: If your TV is muted, pressing 🔊 unmutes the sound.</p>
13	🔇 (volume down)	<p>Turns the volume down one setting with each press. Press and hold to turn the volume down rapidly. A volume indicator shows the volume level while you are adjusting the volume and for a few seconds afterward.</p> <p>Note: If your TV is muted, pressing 🔇 does not unmute the sound.</p>
14	🔇 (mute)	<p>Mutes and unmutes the TV sound. A volume indicator shows the current volume level and a mute icon when you press 🔇 and for a few seconds afterward. If Closed captioning is set to When Mute, captions are displayed while your TV is muted.</p>

Connecting a cable or satellite box

Many cable or satellite TV boxes have more than one connection type. To get the best video, you should use the best connection type available. For more information, see [What connection should I use?](#) on page 16.

You can connect your cable or satellite box using:

- HDMI® (best)
- AV (good)
- Coaxial (good)

HDMI® (best)

Note For better picture quality, we recommend that you use cables designated as High Speed HDMI® cables.

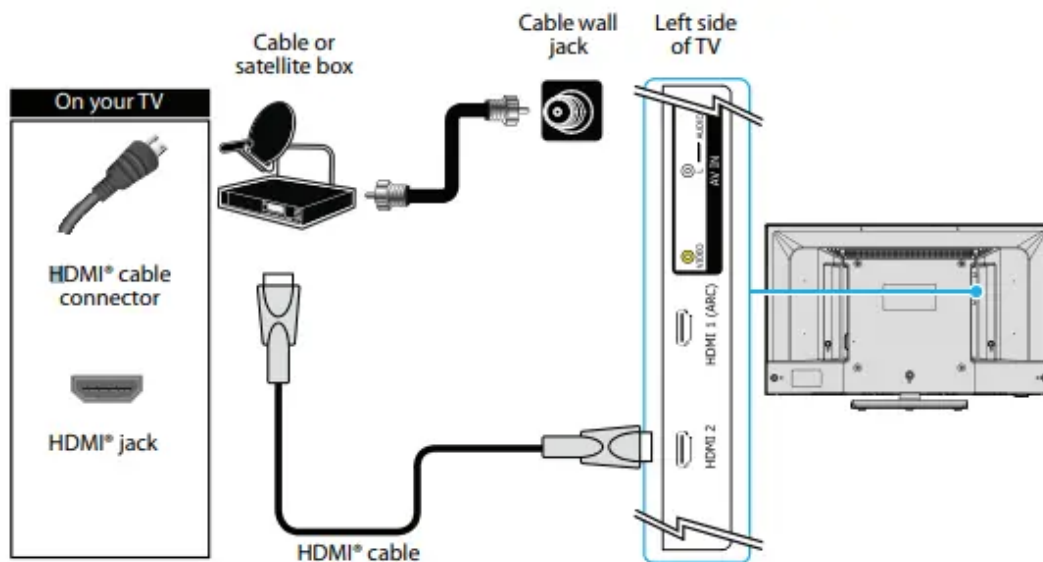

1. Make sure that your TV's power cord is unplugged and all connected devices are turned off.
2. Connect the incoming cable from the cable wall jack to the cable-in jack on the cable or satellite box.
3. Connect an HDMI® cable (not provided) to an HDMI jack on your TV and to the HDMI OUT jack on the cable or satellite box.
4. Plug your TV's power cord into a power outlet, turn on your TV, then turn on the cable or satellite box.
5. On the Home screen, press \wedge \vee $<$ or $>$ to highlight the HDMI 1, HDMI 2, or HDMI 3 tile, then press OK.

Note An HDMI® cable carries both audio and video. You do not need to use any audio cables.

AV (good)

Notes Cables are often color-coded to match color-coded jacks.

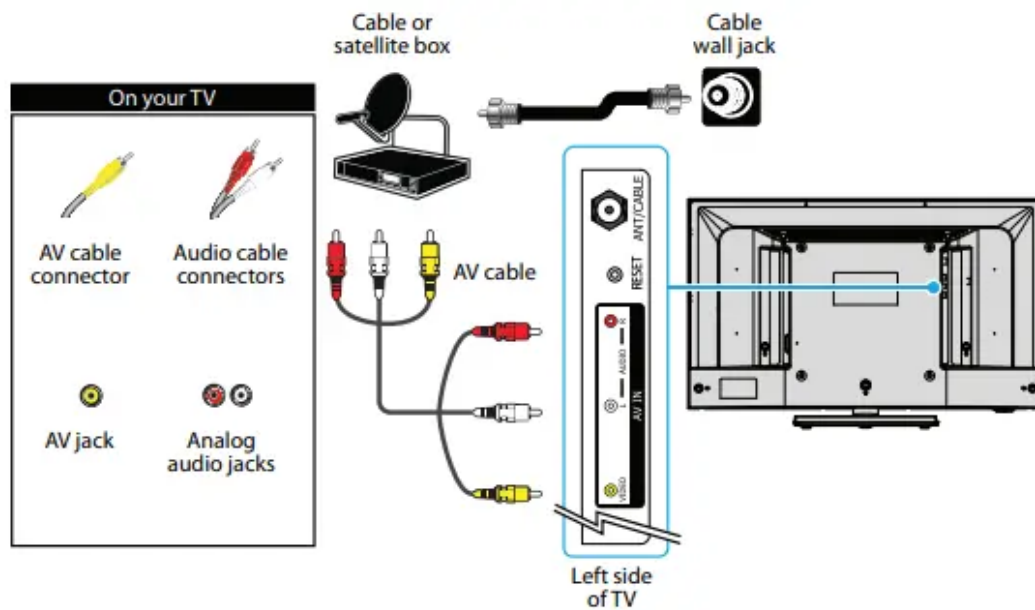

1. Make sure that your TV's power cord is unplugged and all connected devices are turned off.
2. Connect the incoming cable from the cable wall jack to the cable-in jack on the cable or satellite box.
3. Connect an AV cable (not provided) to the VIDEO jack and L and R AUDIO jacks on your TV and to the AV and audio out jacks on the cable or satellite box. **Note** When you connect the audio using the L and R AUDIO jacks, the audio output is analog.
4. Plug your TV's power cord into a power outlet, turn on your TV, then turn on the cable or satellite box.
5. On the Home screen, press \wedge \vee $<$ or $>$ to highlight the AV tile, then press OK.

Coaxial (good)

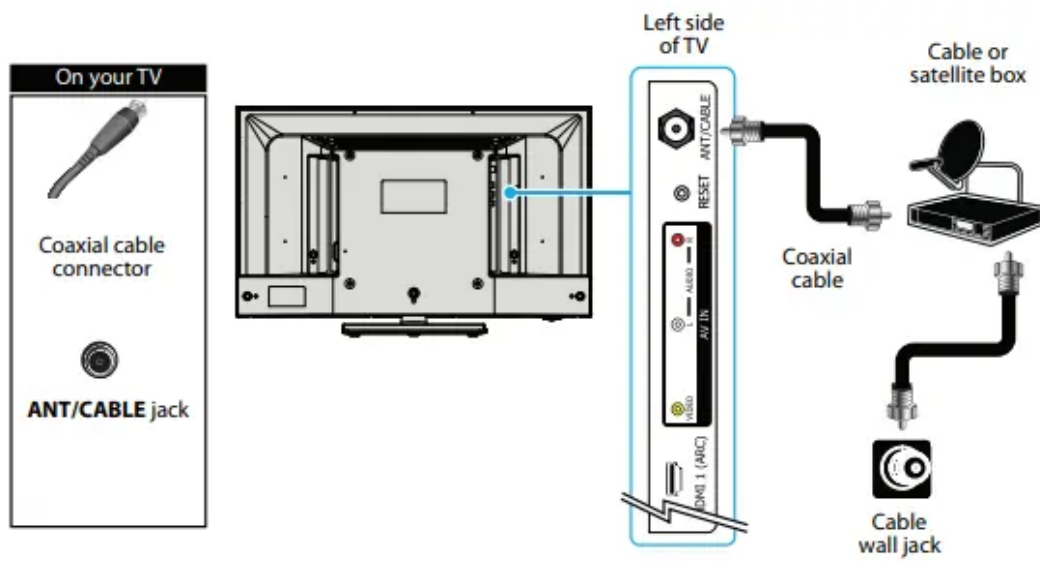

1. Make sure that your TV's power cord is unplugged and all connected devices are turned off.
2. Connect the incoming cable from the cable wall jack to the cable-in jack on the cable or satellite box.
3. Connect a coaxial cable (not provided) to the ANT/CABLE jack on your TV and to the coaxial out jack on the cable or satellite box.
4. Plug your TV's power cord into a power outlet, turn on your TV, then turn on the cable or satellite box.
5. On the Home screen, press \wedge \vee $<$ or $>$ to highlight the Antenna TV tile, then press OK. If you have not set up the TV tuner, follow the on-screen instructions.

Notes

- Use a coaxial cable to eliminate interference and noise from radio waves.
- Do not bundle the coaxial cable with the power cord or other cables.

Connecting an antenna or cable TV (no box)

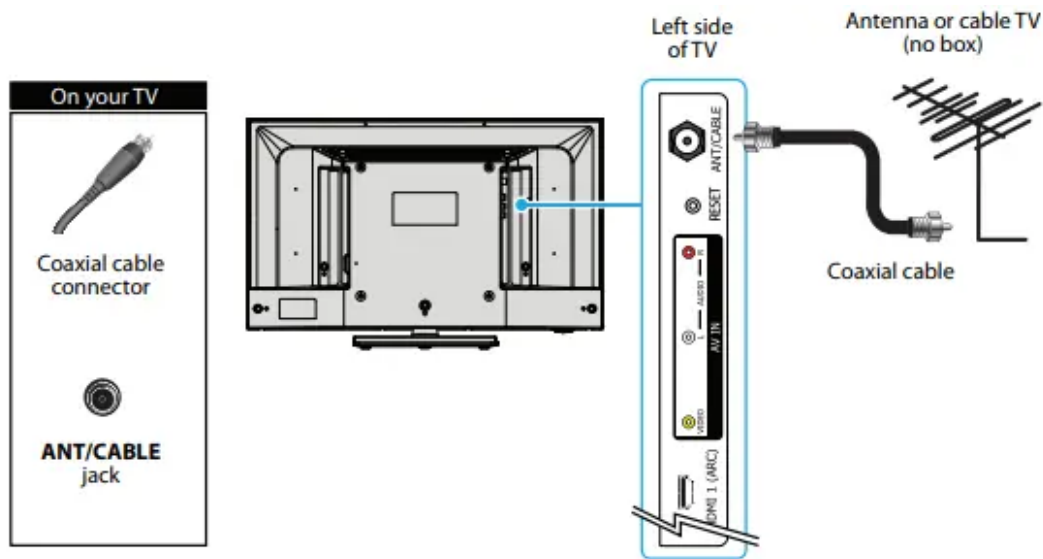

1. Make sure that your TV's power cord is unplugged and all connected devices are turned off.
2. Connect a coaxial cable (not provided) to the ANT/CABLE jack on your TV and to the antenna or cable TV wall jack.
3. Plug your TV's power cord into a power outlet, then turn on your TV.
4. On the Home screen, press \wedge \vee $<$ or $>$ to highlight the Antenna TV tile, then press OK. If you have not set up the TV tuner, follow the on-screen instructions.

Notes

- Use a coaxial cable to eliminate interference and noise from radio waves.
- Do not bundle the coaxial cable with the power cord or other cables.
- If the antenna is not installed correctly, contact qualified service personnel to correct the problem.
- If the signal level for a channel is weak, the picture may be distorted. Adjust the antenna or use a highly directional outdoor or set-top antenna with a built-in amplifier.
- If the picture quality is good on some channels and poor on others, the problem may be caused by a poor or weak signal from the broadcaster or cable TV provider.
- If you connect to cable TV without a set-top box and experience poor picture quality, you may need to install a set-top box to improve signal reception and picture quality. Contact your cable TV provider about upgrading to a set-top box.
- Many high-definition (HD) channels upscale standard-definition (SD) content. The picture displayed on your TV is still displayed as SD, thus the picture quality will not be as clear or crisp as it would be if the content was originally recorded in HD.

Connecting a computer

You can use an HDMI® jack on your TV to connect to a computer.

Note For better picture quality, we recommend that you use cables designated as High Speed HDMI® cables.

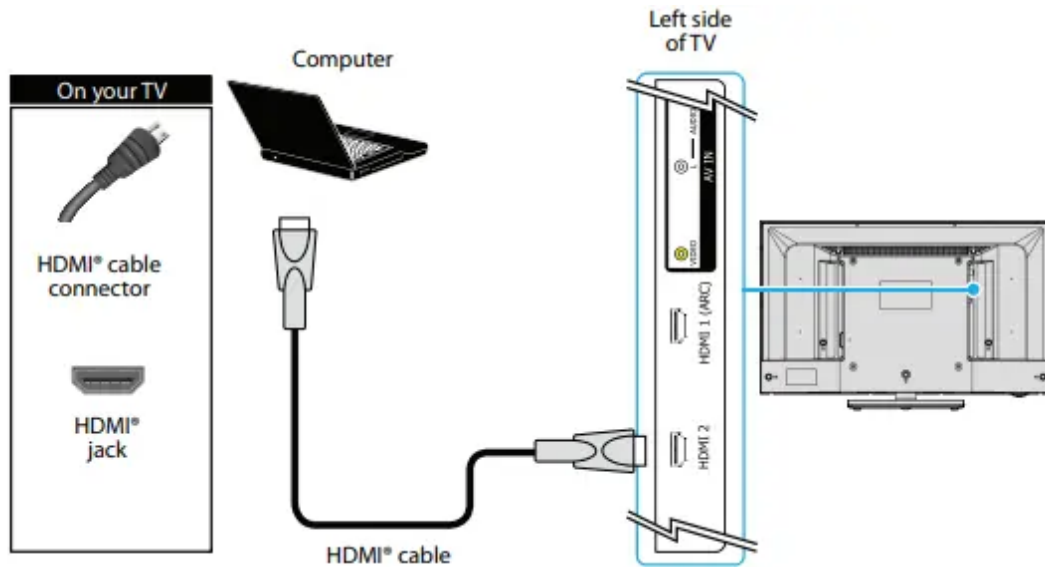

1. Make sure that your TV's power cord is unplugged and the computer is turned off.
2. Connect an HDMI® cable (not provided) to an HDMI jack on your TV and to the HDMI OUT jack on the computer.
3. Plug your TV's power cord into a power outlet, then turn on your TV and the computer.
4. On the Home screen, press \wedge \vee $<$ or $>$ to highlight the HDMI 1, HDMI 2, or HDMI 3 tile, then press OK.
5. Adjust the display properties on the computer, if necessary

Connecting a USB flash drive

When you connect a USB flash drive to the USB jack on your TV, you can view photos and videos or listen to music stored on the drive or you can use the Live TV Pause feature to pause live TV for up to 90 minutes.

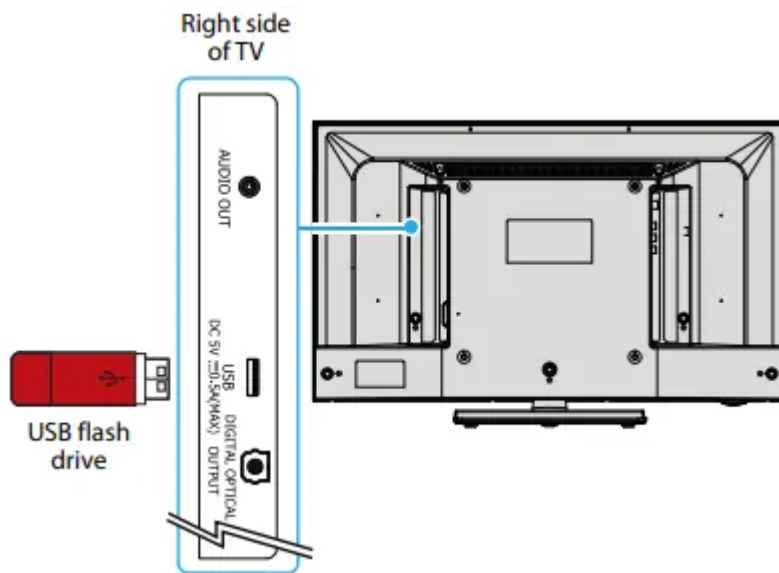

1. Plug a USB flash drive into the USB port on your TV.

Caution Do not remove the USB flash drive or turn off your TV while using the USB flash drive. You may lose data or damage the USB flash drive.

2. Press or to highlight the Roku Media Player or USB Media Player tile, then press OK.

Connecting headphones

When you connect headphones, your TV speakers are muted and sound only plays through the headphones.

Warning Loud noise can damage your hearing. When using headphones, use the lowest volume setting on your headphones that still lets you hear the sound.

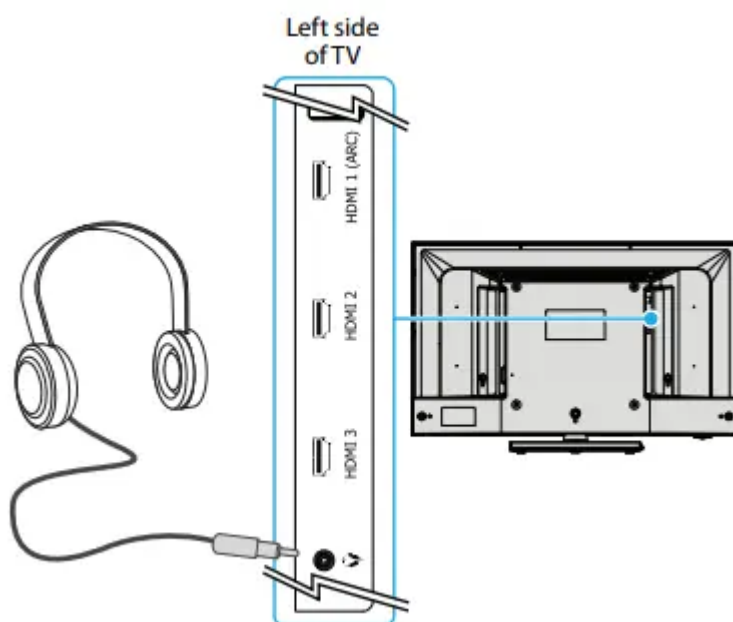

- Connect the headphones to the  jack on your TV.

Note You can also connect a home theater system, sound bar, or external speaker system to the  jack.

Connecting a home theater system with multiple devices

You can connect an AV receiver and your devices to create a home theater.

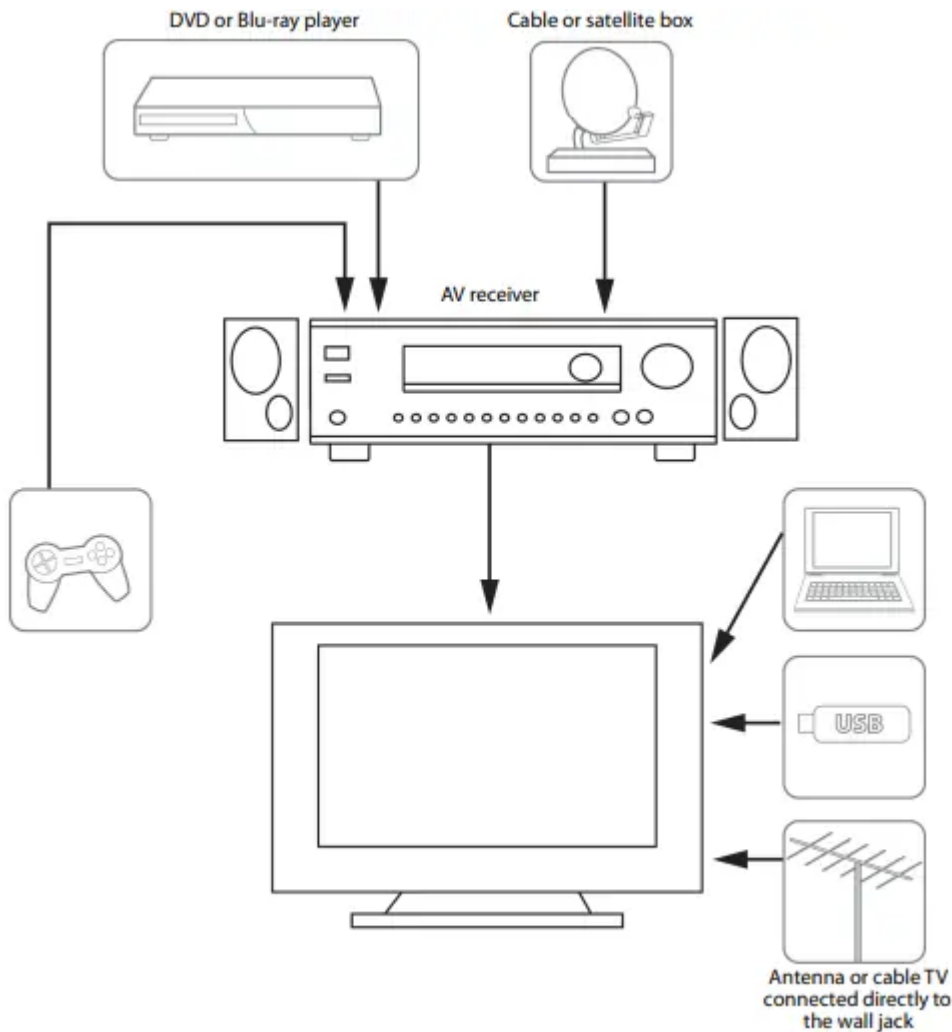

The connections you make depend on the video and audio jacks available on your devices. Refer to the documentation that came with your devices for connection information.

Just remember to use the best connection types available for the best picture and sound. For information about connection types, see [What connection should I use?](#) on page 16.

Connecting power

You should connect devices before you connect the power cord. When you are adding devices, make sure that the power cord is unplugged from the power outlet.

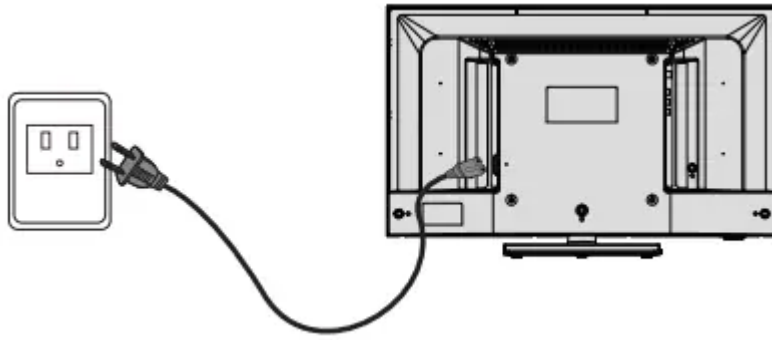

1. Connect the power cord to the power connector on your TV.
2. Connect the other end of the cord to a power outlet.

Caution

- Your TV should only be operated from the power source indicated on the label.
- Always unplug the power cord from the power outlet when you will not be using your TV for an extended period of time.

Setting up your TV

When you turn on your TV for the first time, Guided Setup starts. During Guided Setup:

- Your TV automatically detects your wireless network, so have your network name and password handy and follow the easy on-screen instructions.

Note Roku accounts are free, and while a valid credit card number is not required, providing your card information makes renting and purchasing entertainment a breeze.

- After you are connected to your account, your TV automatically updates with the latest software, and you can start streaming immediately.

Note If you aren't ready to connect your TV to a wireless network, you can still use it as a regular TV.

Maintaining

- Do not use your TV in areas that are too hot or too cold, because the cabinet may warp or the screen may malfunction. Your TV works best in temperatures that are comfortable to you.
- Storage temperatures are 5° to 113°F (-15° to 45°C).
- Working temperatures are 41° to 95°F (5° to 35°C).
- Do not place your TV in direct sunlight or near a heat source.

Cleaning your TV cabinet

Clean the cabinet with a soft, lint-free cloth. If the cabinet is especially dirty, moisten a soft, lint-free cloth in a weak detergent solution, squeeze the excess moisture from the cloth, then wipe the cabinet with the cloth. Use a clean cloth to dry the cabinet.

Cleaning your TV screen

Clean the screen with a soft, lint-free cloth.

Troubleshooting

Warning Do not try to repair your TV yourself. Contact authorized service personnel.

Note If the problem is not solved by using these troubleshooting instructions, turn off your TV, then turn it on again.

Video and audio

Symptom	Possible cause	Try this...
Picture does not fill the screen or there are black bars around the picture	The picture size may need to be adjusted	<ul style="list-style-type: none"> • Adjust the picture size (aspect ratio). See the Picture Size option in the Options menu.
I don't see a picture when I select an input	TV is not on	<ul style="list-style-type: none"> • Make sure that your TV is plugged into a working power outlet, and that your TV is turned on. (Your TV has a light on the front that indicates if your TV is turned off.)
	Cables are not connected correctly	<ul style="list-style-type: none"> • Make sure that the video cables are connected correctly and securely to your TV. • Make sure that the antenna or cable TV is connected correctly and securely. See Connecting a cable or satellite box on page 17 or Connecting an antenna or cable TV (no box) on page 20.
	Picture settings may be incorrect	<ul style="list-style-type: none"> • Adjust the contrast and brightness. See the TV brightness option in the <i>Settings</i> menu or <i>Options</i> menu. • Adjust the TV picture.
	Incorrect input may be selected	<ul style="list-style-type: none"> • Make sure that the correct input is selected for the device you want to view.
	Input source not detected	<ul style="list-style-type: none"> • Make sure that the device connected to the input is turned on. • Make sure that the cord to and from the device is connected firmly and correctly to the device and your TV.
	TV input may be bad	<ul style="list-style-type: none"> • Connect a different device to the same input and check to see if it works correctly.
TV channel does not appear	Broadcast TV may be experiencing problems or may not be set up	<ul style="list-style-type: none"> • Try another channel. The station may be experiencing problems. • Make sure that the incoming signal is compatible.

- | | | |
|--|--|---|
| | | <ul style="list-style-type: none">• If you are trying to watch broadcast TV, make sure that Antenna TV is set up. |
|--|--|---|



Dark, poor, or no picture (screen is lit), but sound is good	Broadcast TV may be experiencing problems or may not be set up	<ul style="list-style-type: none"> • Try another channel. The station may be experiencing problems. • If you are using an antenna and the signal strength is low, adjust the antenna or use a highly directional outdoor antenna or set-top antenna with a built-in amplifier.
	Cables may not be connected correctly	<ul style="list-style-type: none"> • Make sure that the antenna or cable TV is connected correctly and securely. See <i>Connecting a cable or satellite box</i> on page 17 or <i>Connecting an antenna or cable TV (no box)</i> on page 20. • Make sure that the video cables are connected correctly and securely to your TV. • The video cable(s) you are using may be bad. Try a new set.
	Picture settings may be incorrect	<ul style="list-style-type: none"> • Adjust the brightness. See the TV brightness option in the <i>Settings</i> menu or <i>Options</i> menu. • Change to a different picture mode. See the Picture mode option in the <i>Options</i> menu or <i>Advanced Picture Settings</i> menu.
No color, dark picture, or color is not correct	Picture settings may be incorrect	<ul style="list-style-type: none"> • Adjust the contrast, color, and brightness settings. See the TV brightness option in the <i>Settings</i> menu or the <i>Options</i> menu.
	Broadcast TV may be experiencing problems	<ul style="list-style-type: none"> • Try another channel. The station may be experiencing problems. • If you are using an antenna and the signal strength is low, adjust the antenna or use a highly directional outdoor antenna or set-top antenna with a built-in amplifier.
	Cables are not connected correctly	<ul style="list-style-type: none"> • Make sure that the antenna or cable TV is connected correctly and securely. See <i>Connecting a cable or satellite box</i> on page 17 or <i>Connecting an antenna or cable TV (no box)</i> on page 20. • Make sure that the video cables are connected correctly and securely to your TV. • The video cable(s) you are using may be bad. Try a new set.

Only snow (noise) appears on the screen	Broadcast TV may be experiencing problems or may not be set up	<ul style="list-style-type: none"> • Try another channel. The station may be experiencing problems. • If you are trying to watch broadcast TV, make sure that Antenna TV is set up. • If you are using an antenna and the signal strength is low, adjust the antenna or use a highly directional outdoor antenna or set-top antenna with a built-in amplifier.
	Cables may not be connected correctly	<ul style="list-style-type: none"> • Make sure that the antenna or cable TV is connected correctly and securely. See Connecting a cable or satellite box on page 17 or Connecting an antenna or cable TV (no box) on page 20.
Picture quality is good on some channels and poor on others. Sound is good	Broadcast signal may be weak	<ul style="list-style-type: none"> • If you connect to cable without a set-top box and experience poor picture quality, you may need to install a set-top box to improve signal reception and picture quality. Contact your cable TV provider about upgrading to a set-top box.

Dotted lines or stripes appear on the screen	Cables may not be connected correctly	<ul style="list-style-type: none"> • Make sure that the antenna or cable TV is connected correctly and securely. See Connecting a cable or satellite box on page 17 or Connecting an antenna or cable TV (no box) on page 20. • Make sure that the video cables are connected correctly and securely to your TV. • The video cable(s) you are using may be bad. Try a new set.
	Broadcast signal may be weak	<ul style="list-style-type: none"> • If you are using an antenna and the signal strength is low, adjust the antenna or use a highly directional outdoor antenna or set-top antenna with a built-in amplifier. • Other devices (for example, a surround sound receiver, external speakers, fans, or hair dryers) may be interfering with your TV. Try turning off one device at a time to determine which device is causing interference. After you have determined which device is causing interference, move it further from your TV to eliminate the interference.
Double images	Broadcast signal may be weak	<ul style="list-style-type: none"> • If you are using an antenna and the signal strength is low, adjust the antenna or use a highly directional outdoor antenna or set-top antenna with a built-in amplifier. • If you are using an antenna and the signal strength is low, switch to a cable or satellite box.
The picture has a few bright or dark spots	This is normal in LED TVs	<ul style="list-style-type: none"> • A few bright or dark spots on a TV screen is normal. It does not affect the operation of your TV.
Good picture, but no sound	Volume is down or muted	<ul style="list-style-type: none"> • Increase the volume. • Make sure that the sound is not muted.
	Headphones may be connected	<ul style="list-style-type: none"> • Make sure that you do not have headphones connected. When headphones are connected, no sound comes from your TV speakers.

<p>TV speakers may be turned off</p>	<ul style="list-style-type: none"> • If you want sound to play through your TV speakers, make sure that your TV speakers are turned on.
<p>You may need to change the audio mode</p>	<ul style="list-style-type: none"> • Change to a different audio mode.
<p>Home theater system, sound bar, or external speaker system may not be turned on or may not be set up correctly</p>	<ul style="list-style-type: none"> • If you are using a home theater system, sound bar, or external speaker system, make sure that it is turned on and is not muted and that it is set to the correct source. • If you connected an ARC audio device to the HDMI 1 (ARC) jack, make sure that you have turned on the ARC feature. • If you are using a home theater system, sound bar, or external speaker system and have connected it with a digital audio cable, make sure that you have set up the digital audio connection. • Make sure that the audio cables are connected correctly and securely to your TV.
<p>Bad content, no audio</p>	<ul style="list-style-type: none"> • Make sure that the selected channel or content is intended to be broadcasting with sound.
<p>Cables may not be connected correctly</p>	<ul style="list-style-type: none"> • Make sure that the antenna or cable TV is connected correctly and securely. See Connecting a cable or satellite box on page 17 or Connecting an antenna or cable TV (no box) on page 20. • The audio cables you are using may be bad. Try a new set.



Poor picture	Light in the viewing area may be interfering	<ul style="list-style-type: none"> • Make sure that the room is not too bright. Light reflecting off the screen can make the picture difficult to see.
	A connected camera or camcorder may be interfering	<ul style="list-style-type: none"> • If an S-VHS camera or a camcorder is connected while another connected device is turned on, the picture may be poor. Turn off one or more devices.
Audio noise	Other devices may be interfering	<ul style="list-style-type: none"> • Other devices (for example, a surround sound receiver, external speakers, fans, or hair dryers) may be interfering with your TV. Try turning off one device at a time to determine which device is causing interference. After you have determined which device is causing interference, move it further from your TV to eliminate the interference.
After images appear		<ul style="list-style-type: none"> • Do not display a still image, such as a logo, game, or computer image, for an extended period of time. This can cause a permanent after-image to be burned into the screen. This type of damage is not covered by your warranty.

Remote control

Symptom	Possible cause	Try this...
My TV doesn't turn on using the remote control	No power to TV	<ul style="list-style-type: none"> • Make sure that the power cord is correctly connected to both your TV power connector and power outlet. See Connecting power on page 32. You should see an LED in the front of the TV panel when a button on the remote is pressed. If you see no LED activity, try another outlet or check your fuse box.
	Line-of-sight obstructed	<ul style="list-style-type: none"> • Make sure that no objects (or pets) are obstructing the line-of-sight from the remote control to the remote sensor on the front of your TV. See Aiming the remote control on page 33.
	Remote not responding	<ul style="list-style-type: none"> • Open the battery compartment and make sure that the batteries are seated in the correct positions (+ and - in the correct positions). See Installing remote control batteries on page 33. • Make sure that the batteries are fresh and working correctly. Replace the batteries, if necessary.
	TV frozen	<ul style="list-style-type: none"> • If the front LED is not responding, or abnormally bright, disconnect the power cord from the power outlet, wait a few seconds, then reconnect the power cord.
Trouble programming your existing universal remote control	Remote control may not be programmed correctly	<ul style="list-style-type: none"> • For instructions on programming a universal remote control, visit website. • Refer to the User Guide that accompanied your universal remote control and contact the manufacturer if problems persist.
	Batteries may be dead	<ul style="list-style-type: none"> • Replace dead batteries with new batteries. Refer to the User Guide that accompanied your universal remote control.

General

Symptom	Possible cause	Try this...
No power	Power cord may not be connected correctly	<ul style="list-style-type: none"> • Make sure that the power cord is correctly connected to both your TV power connector and power outlet. See Connecting power on page 32. You should see an LED in the front of your TV panel when a button on the remote is pressed. If you see no LED activity, try another outlet or check your fuse box. • Unplug the power cord, wait 60 seconds, then plug the cord back in and turn on your TV.
	Other devices may be interfering	<ul style="list-style-type: none"> • Other devices (for example, a surround sound receiver, external speakers, fans, or hair dryers) may be interfering with your TV. Try turning off one device at a time to determine which device is causing interference. After you have determined which device is causing interference, move it further from your TV to eliminate the interference.
My TV tuner does not pick up as many over-the-air channels as it should	Antenna may not be placed optimally	<ul style="list-style-type: none"> • Adjust the antenna location and rescan. <p>Go to Settings > TV inputs > Antenna TV > Scan again for channels.</p> <ul style="list-style-type: none"> • Reception can vary by channel depending on the broadcast power level of a given station. Contact your cable or satellite TV provider. • Make sure that the antenna or cable/satellite TV is connected securely to your TV. • Try replacing the cable between the antenna/cable or cable/satellite box and your TV.
	Broadcast TV may not be set up	<ul style="list-style-type: none"> • Make sure that Antenna TV is set up.
One or more channels do not display	Channels may be blocked or hidden	<ul style="list-style-type: none"> • Make sure that the channels are not blocked. • Make sure that the channels are not hidden. The channel may have been deleted from the channel list. You can add the channel back to the channel list.



	The wrong input may be selected	<ul style="list-style-type: none"> • Make sure that you have selected the correct input tile for the device or service you are trying to use.
	You may need to use the remote control that came with the cable or satellite box	<ul style="list-style-type: none"> • If you are using a cable or satellite box, use the remote that came with that box to change channels.
I lost my parental control PIN	Need PIN recovery	<ul style="list-style-type: none"> • You will need to factory reset your TV, as the PIN cannot be recovered or reset any other way. <p>Go to Settings > System > Advanced system settings > Factory reset.</p>
Some settings cannot be accessed	Not all settings are available for all devices or inputs	<ul style="list-style-type: none"> • If the * icon or a menu option is grayed, you cannot adjust settings for the current video input mode.
TV cabinet creaks	This is normal	<ul style="list-style-type: none"> • When your TV is in use, the temperature rises naturally and may cause the cabinet to expand or contract which can cause a creaking noise. This is not a malfunction.
Control buttons do not work	TV may be frozen	<ul style="list-style-type: none"> • Unplug the power cord, wait a few seconds, then plug the cord back in and turn on your TV.
TV keeps turning off	Sleep timer may be turned on	<ul style="list-style-type: none"> • Make sure that the sleep timer is not turned on.
Some features are not available	The wrong TV mode may be selected	<ul style="list-style-type: none"> • You may have Set up for store mode when you set up your TV. Store use mode is for retail environments only. In Store use mode, some of your TV's features are missing or limited. If you selected Set up for store use and you want to change to Set up for home use, you have to reset your TV to the factory defaults. <p>Go to Settings > System > Advanced system settings > Factory reset.</p>

Roku

Symptom	Possible cause	Try this...
How can I find out more about using my TV?		<ul style="list-style-type: none">• If you need help with using your TV or Roku, go to website.
I can't turn my TV on with the Roku mobile aPP	Your TV is "asleep"	<ul style="list-style-type: none">• You will need to use the physical remote button to "wake up" or turn on your TV.
I can't find my TV with the Roku mobile app	TV and mobile app not on same wireless network	<ul style="list-style-type: none">• Make sure that your TV and the mobile app are on the same network.
	TV not powered or working normally	<ul style="list-style-type: none">• Make sure that your TV is connected to a working power outlet and that your TV is turned on. See Connecting power on page 32.

Network

Symptom	Possible cause	Try this...
I cannot connect to the internet	Network connection may not be set up	<ul style="list-style-type: none">• If you did not connect to the internet when you first set up your TV, set up a network connection.
	Network name or password may have changed	<ul style="list-style-type: none">• If your network name or password has changed, you need to update your network connection.
Streaming keeps pausing to load more data	Wireless LAN not optimized	<ul style="list-style-type: none">• Rotate wireless router slightly• Elevate the router• Turn off other wireless connections• Use 5.0Ghz, if possible. Roku TVs support dual band.
	Insufficient broadband speed	<ul style="list-style-type: none">• Turn off other wireless connections that may also be using bandwidth.

CEC-compatible devices



Symptom	Possible cause	Try this...
My TV is not displaying the video from the connected CEC device	Cables may not be connected correctly	<ul style="list-style-type: none"> • Make sure that the HDMI® cable is connected securely to your TV and the device. • Make sure that the device is connected to your TV with an HDMI® cable.
	Picture settings may be incorrect	<ul style="list-style-type: none"> • Try adjusting your TV picture.
	The selected input may be incorrect	<ul style="list-style-type: none"> • Make sure that the correct input tile is selected.
	Connected device may not be a CEC device	<ul style="list-style-type: none"> • Make sure that the device is a CEC device. See the documentation that came with the device for more information.
	CEC control may not be set up correctly	<ul style="list-style-type: none"> • Make sure that your TV has searched for CEC devices.
My TV is not playing the audio from the connected CEC device.	Cables may not be connected correctly	<ul style="list-style-type: none"> • Make sure that the HDMI® cable is connected securely to your TV and the device.
	Volume may be too low or muted	<ul style="list-style-type: none"> • Make sure that the volume on your TV and the device is turned up and not muted.
	TV speakers may be turned off	<ul style="list-style-type: none"> • If you want sound to play through your TV speakers, make sure that your TV speakers are turned on.
	Connected device may not be a CEC device	<ul style="list-style-type: none"> • Make sure that the device is a CEC device. See the documentation that came with the device.
	CEC control may not be set up correctly	<ul style="list-style-type: none"> • Make sure that your TV has searched for CEC devices.

	<p>Connected audio device may not be set up correctly</p>	<ul style="list-style-type: none"> • If you are using a home theater system, sound bar, or external speaker system, make sure that it is set to the correct source. • If you are using a home theater system, sound bar, or external speaker system and have connected it with a digital audio cable, make sure that you have set up digital audio. • If you connected an ARC audio device to the HDMI 1 (ARC) jack, make sure that you have turned on the ARC feature.
<p>My TV's remote control does not control the device</p>	<p>Connected device may not be turned on</p>	<ul style="list-style-type: none"> • Make sure that the device is turned on.
	<p>Line-of-sight obstructed</p>	<ul style="list-style-type: none"> • Make sure that no objects (or pets) are obstructing the line-of-sight from the remote control to the remote sensor on the front of your TV and the device.
	<p>Connected device may not support some or all CEC features</p>	<ul style="list-style-type: none"> • Depending on the device, all the buttons may not work. • The device may not support this feature. See the documentation that came with the device for more information.
	<p>CEC control may not be set up correctly</p>	<ul style="list-style-type: none"> • Make sure that your TV has searched for CEC devices. • If you are trying to control the volume on an HDMI® CEC audio receiver using your TV remote control, make sure that your TV speakers are turned on. • If you are trying to control the volume on an HDMI® CEC audio receiver using your TV remote control, make sure that the system audio control is turned on.



The device does not show up in the CEC device list	Connected device may not be a CEC device	<ul style="list-style-type: none"> • Make sure that the device is a CEC device. See the documentation that came with the device.
	Cables may not be connected correctly	<ul style="list-style-type: none"> • Make sure that the HDMI® cable is connected securely to your TV and the device. <ul style="list-style-type: none"> • Make sure that the device is connected to your TV with an HDMI® cable.
	CEC control may not be set up correctly	<ul style="list-style-type: none"> • Make sure that your TV has searched for CEC devices.
My device does not turn off when I turn off my TV	Connected device may not be a CEC device	<ul style="list-style-type: none"> • Make sure that the device is a CEC device. See the documentation that came with the device.
	Connected device may not support some or all CEC features	<ul style="list-style-type: none"> • The device may not support this feature. See the documentation that came with the device for more information.
	CEC control may not be set up correctly	<ul style="list-style-type: none"> • Make sure that your TV has searched for CEC devices. • Make sure that system standby is turned on.
My TV does not turn on when I turn on my device	Connected device may not be a CEC device	<ul style="list-style-type: none"> • Make sure that the device is a CEC device. See the documentation that came with the device.
	Connected device may not support some or all CEC features	<ul style="list-style-type: none"> • The device may not support this feature. See the documentation that came with the device for more information.
	CEC control may not be set up correctly	<ul style="list-style-type: none"> • Make sure that your TV has searched for CEC devices. • Make sure that 1-touch play is turned on.

Warning

This content is compiled from multiple sources and is provided for reference purposes only. It may not be complete or fully applicable to all situations. If you are unable to resolve your issue, please contact the product manufacturer or an authorized service provider for official support.

