

## Installation

Power of the docking station must be on at all times.

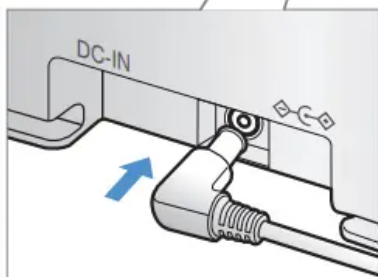

**1** Connect the charger jack to the docking station

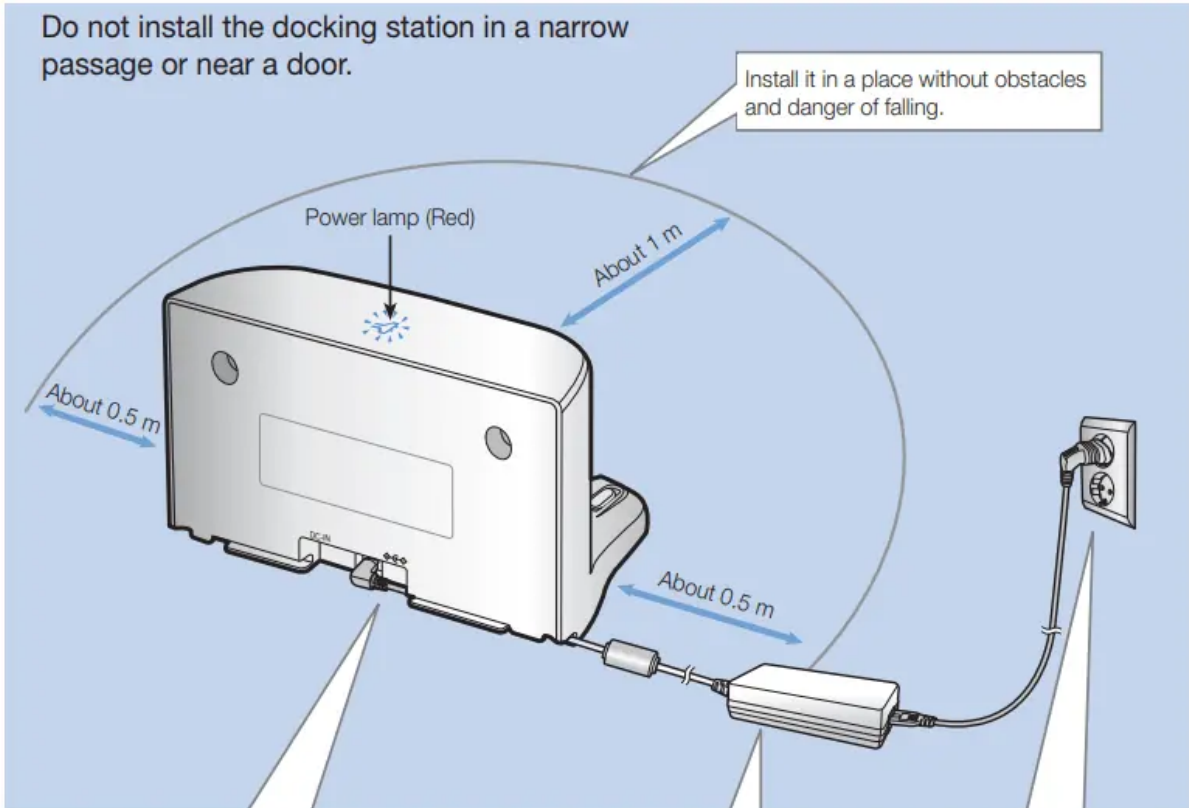
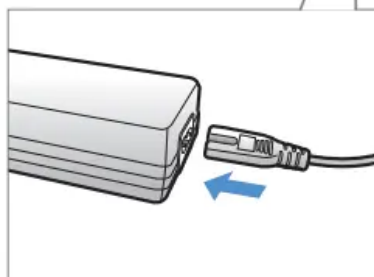

**2** Connect the power cord to the charger

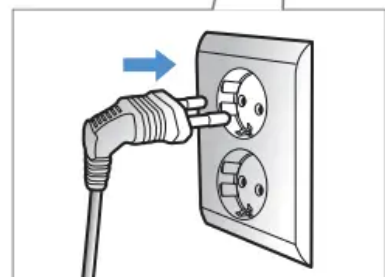

**3** Connect the power plug to the outlet

1. Connect the charger jack to the docking station







2. Connect the power cord to the charger

When using the charger, the side with the sticker attached must face down.

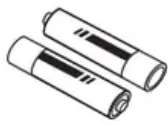
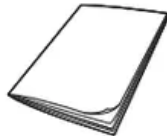
3. Connect the power plug to the outlet

Power lamp (Red) will turn on.

## Accessories

 <p>Remote control</p>	 <p>Batteries (AAA type)</p>	 <p>User manual</p>	 <p>Spare filter</p>	 <p>Cleaning brush</p>
 <p>Docking station</p>	 <p>Power cord</p>	 <p>Charger</p>	 <p>Virtual guard</p>	

## Installation note

### Note

- Install the docking station in a place where the floor and wall are level.
- It is best to install the docking station along the grain of wooden floors.
- If the emergency switch is off, POWERbot will not charge even if it is docked on the docking station.
- Always turn on the power of the docking station.
  - If power is not supplied to the docking station, POWERbot cannot find it and cannot automatically recharge.
  - If POWERbot is left detached from the docking station, the battery will drain naturally.
- If POWERbot is in energy-saving mode, power will not come on even if the emergency switch is turned off and then on. Press and hold the [Start/Stop] button on POWERbot.

## Charging

- It takes approximately 240 minutes to completely charge when charging for the first time after purchase and can be used for approximately 30 minutes in Max mode.
- **WARNING** Rated input voltage of this product is 100 - 240 V~.

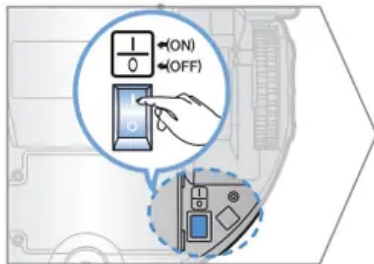
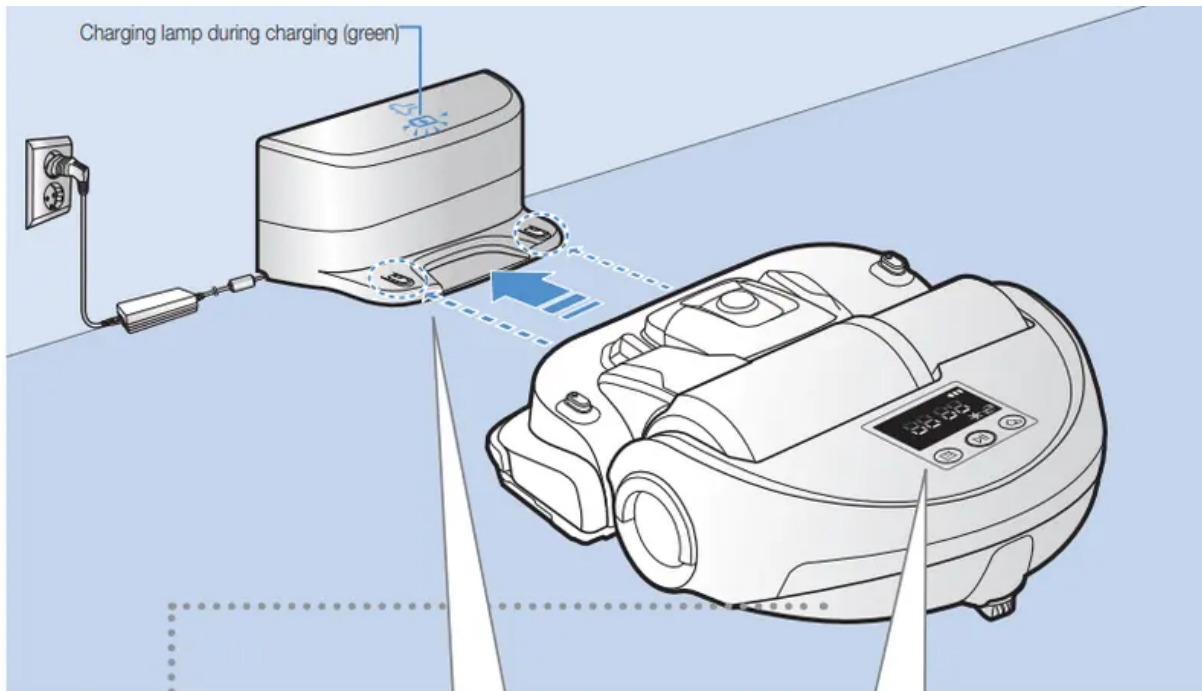

### 1 Turn on the emergency switch on the bottom

You must turn on the emergency switch to turn on POWERbot.

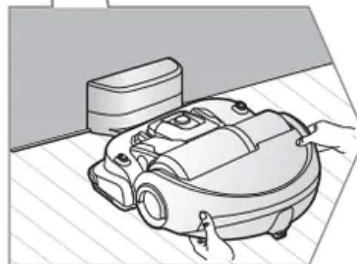

### 2 Manually charge POWERbot by placing it on the docking station

Make sure charge pins of POWERbot and the docking station is aligned.



### 3 Check the charging status

"" will turn on according to charging progress and "FULL" will turn on when charging is complete.

#### 1. Turn on the emergency switch on the bottom

You must turn on the emergency switch to turn on POWERbot.

#### 2. Manually charge POWERbot by placing it on the docking station

Make sure charge pins of POWERbot and the docking station is aligned.

#### 3 Check the charging status

"" will turn on according to charging progress and "FULL" will turn on when charging is complete.

#### Automatic charging

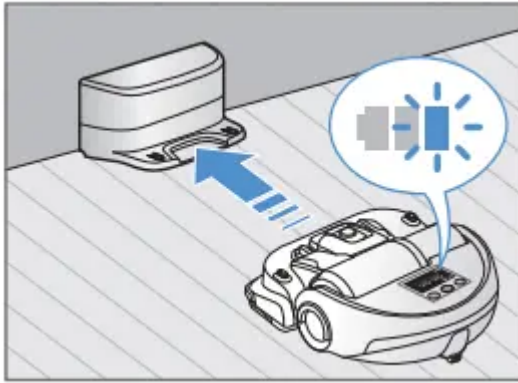

When the battery indicator blinks during cleaning, POWERbot will return to the docking station to charge itself automatically.

### Recharging



You may command poWerbot to recharge at the docking station while it is in cleaning process.

### Low battery (Lo)

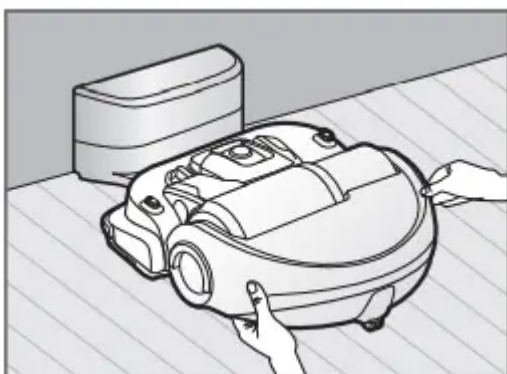

Manually charge poWerbot by placing it on the docking station.

### Steps to take if recharging is not being executed

#### Check the installation status of the docking station when:

- docking station is located in a place where POWERbot cannot easily access

- distance of the docking station and POWERbot is over 5 m apart
  - It may take a long time for POWERbot to return to the docking station for recharging

**Manually charge poWerbot when:**

- docking station is located in a corner
- battery is fully exhausted
- POWERbot is stuck by obstacles (furniture etc.)
- POWERbot can't climb threshold near docking station (Height of the threshold that POWERbot can climb: about 2.0 cm and below)
- Battery indicator blinks and "Lo" is displayed
- POWERbot is set on Spot clean or Manual clean mode

**Installing the Virtual guard**

**Infrared ray from the Virtual guard will restrict POWERbot from approaching certain area.**



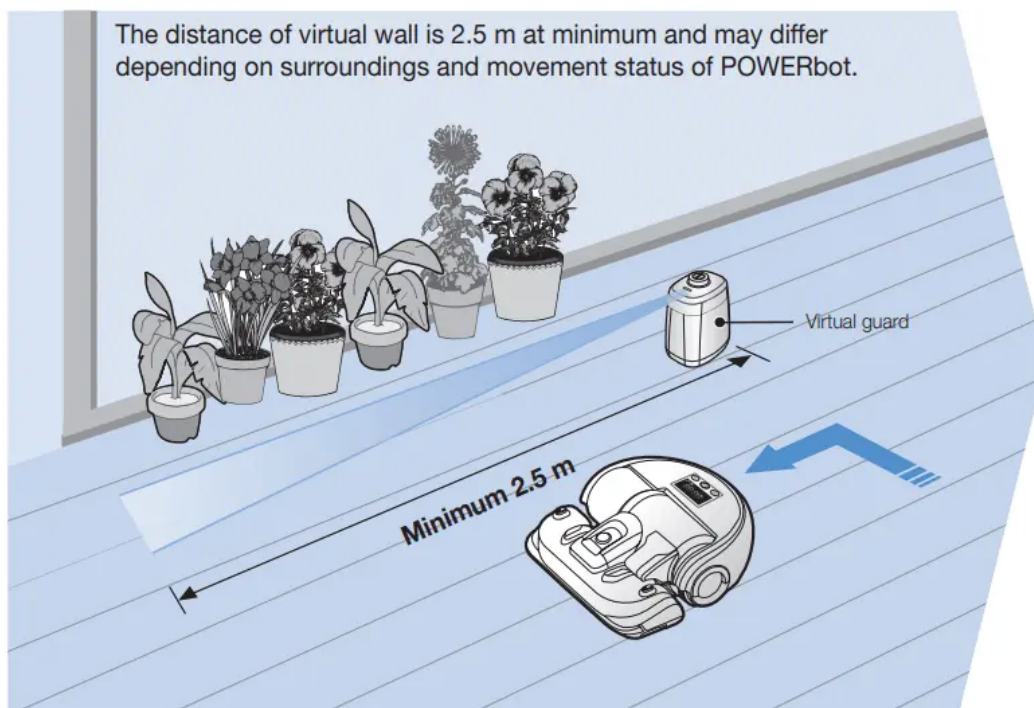

**1. Press the Power button to turn it on**

Power lamp (Red) will blink.



**2. Install the Virtual guard where you want to restrict POWERbot's entrance**

Make sure that distance sensor is facing at the desired direction you want to create a invisible barrier (which will restrict POWERbot's approach).

**Part name of the Virtual guard**

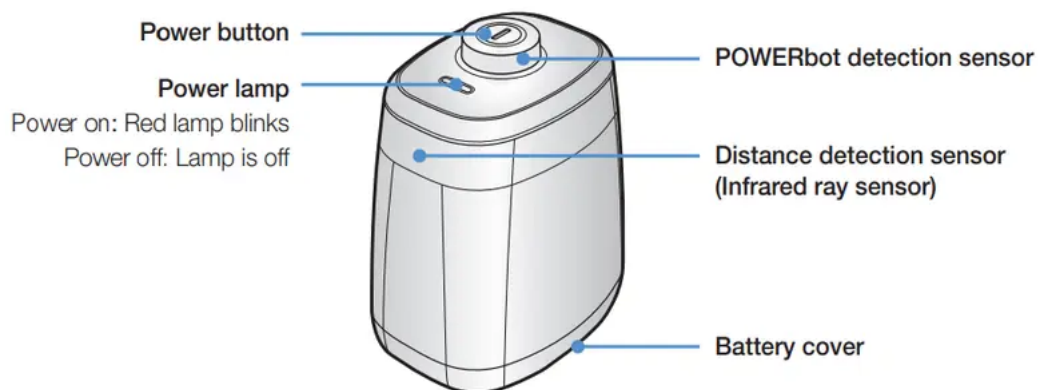

## Inserting batteries

Batteries for Virtual guard must be purchased separately.

1. Open the battery cover of the Virtual guard by pressing the locking tab and lift it up.

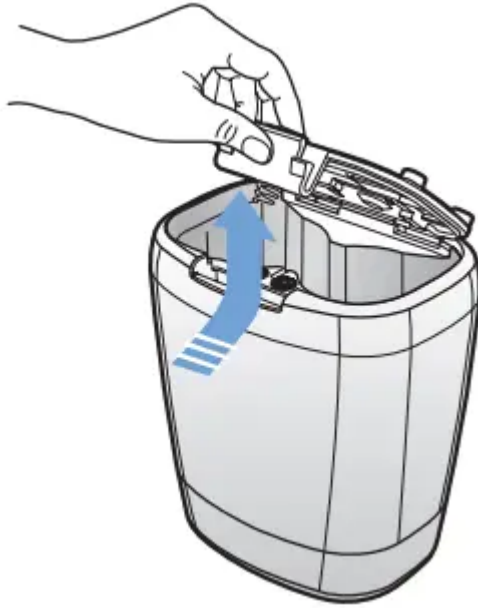

2. Insert the alkaline batteries (D type) as shown in the illustration (check the +, - polarity).

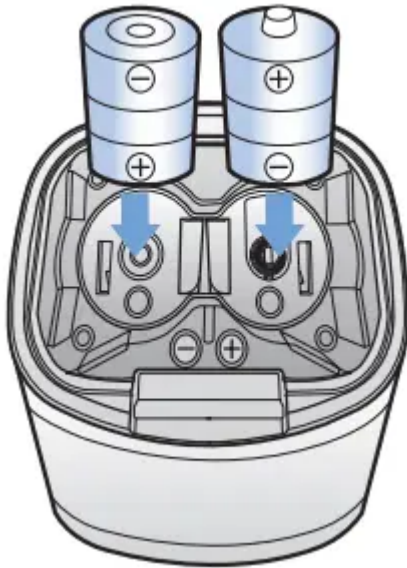

3. Insert the tip of the cover into the slot and push the other end to close the battery cover.

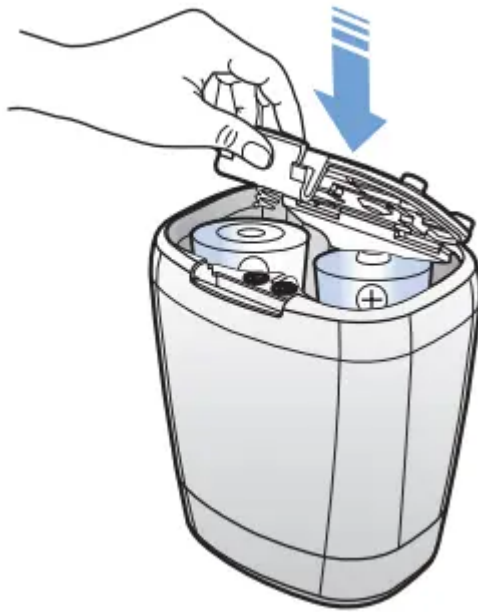

\* Specification: type D (LR20) batteries

## Using POWERbot



You must turn on the emergency switch before using POWERbot.

## Turning the power on/off

Press the  button for more than 3 seconds

- When POWERbot is not used for 30 minutes, it will return to the docking station to charge itself automatically

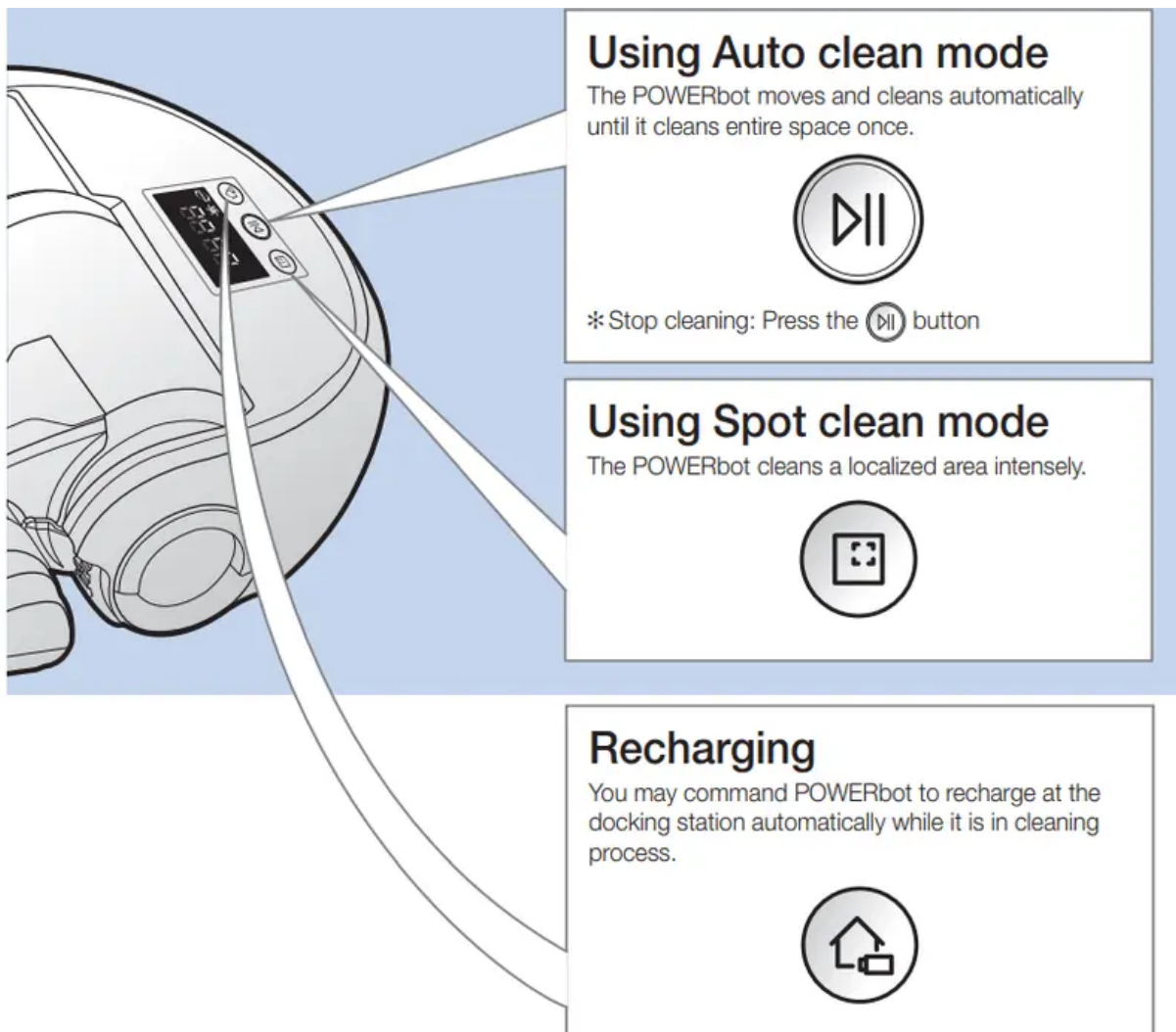



### Location recognizing function

- If turning off the POWERbot and turning it back on, the POWERbot will search the location that it stopped previously and then clean the area where was not cleaned before.
  - When the location recognizing function operates, the POWERbot searches the current location.
  - If the searching is failed more than 3 times, the POWERbot will start to clean from the beginning.

### Note

- Start the cleaning again at the area within 1 m around where the POWERbot stopped.
  - If you start the cleaning at the area more than 1 m from where the POWERbot stopped, it is difficult to search the location and the POWERbot may clean the area where it already cleaned.

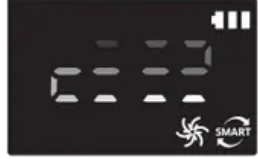
## Selecting cleaning modes

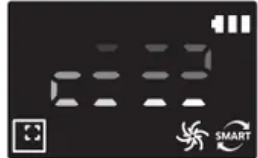
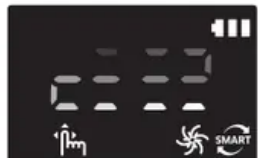
Cleaning mode	How to select	Displayed icon
<b>Auto clean</b>		
<b>Spot clean</b>	 <p>* Spot clean mode can be selected only by pressing this button on the main body of the POWERbot.</p>	
<b>Manual clean</b>	<p>* Manual clean mode can be selected by the direction control buttons of the remote control.</p>	

- When cleaning is done within 15 minutes in Auto clean mode, the POWERbot will repeat cleaning one more time.
- When dust intake is detected in Spot/Manual clean mode, suction of the POWERbot will become stronger.
- If the POWERbot fails to return to the docking station, it will be turned into the energy-saving mode. Then the display panel of the main body will be turned off. Press [Start/Stop] or [Power] button to cancel the energy-saving mode.
- Charging and cleaning times can differ according to conditions of use.

## Cleaning method for each modes

### Auto clean

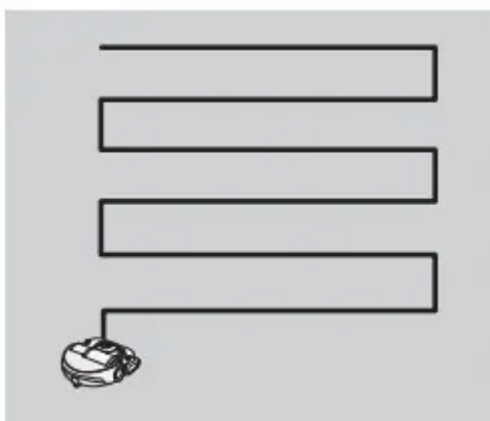

Cleans automatically until entire space is cleaned once.

## Spot clean

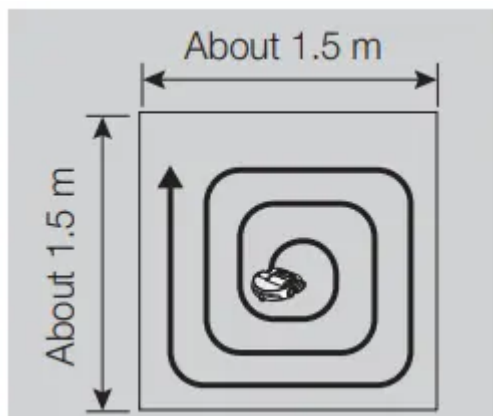

Cleans a localized area intensely. It can be used to clean bread or cookie crumbs.

## Manual clean

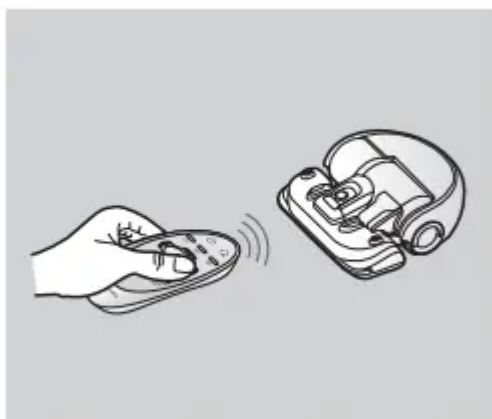



You can move POWERbot with the remote control to clean the desired spot.



## Using special cleaning functions

### Using the remote control



**1 Power / Recharging / Start/Stop**

<b>Power</b>		Turn POWERbot's power on/off
<b>Recharging</b>		Select to recharge POWERbot at the docking station automatically
<b>Start/Stop</b>		Select to start or stop cleaning process

## 2 Suction power

<b>Max mode</b>		Select to clean with the strongest suction power
<b>Normal mode</b>		Select to clean with moderate suction power
<b>Quiet mode</b>		Select to clean with lower operation noise

## 3 Additional function

<b>Sound</b>		Each time you press this button, Sound Effects → Mute is selected in this sequence.
<b>Smart control</b>		Select to turn on or off the smart control <ul style="list-style-type: none"> <li>• Press [Sound] button for 3 seconds..</li> <li>• Wi-Fi connection should be done to control the POWERbot using Samsung Smart Home app.</li> </ul>

\* The previously selected setting will not change even if the emergency switch is turned off and then on.

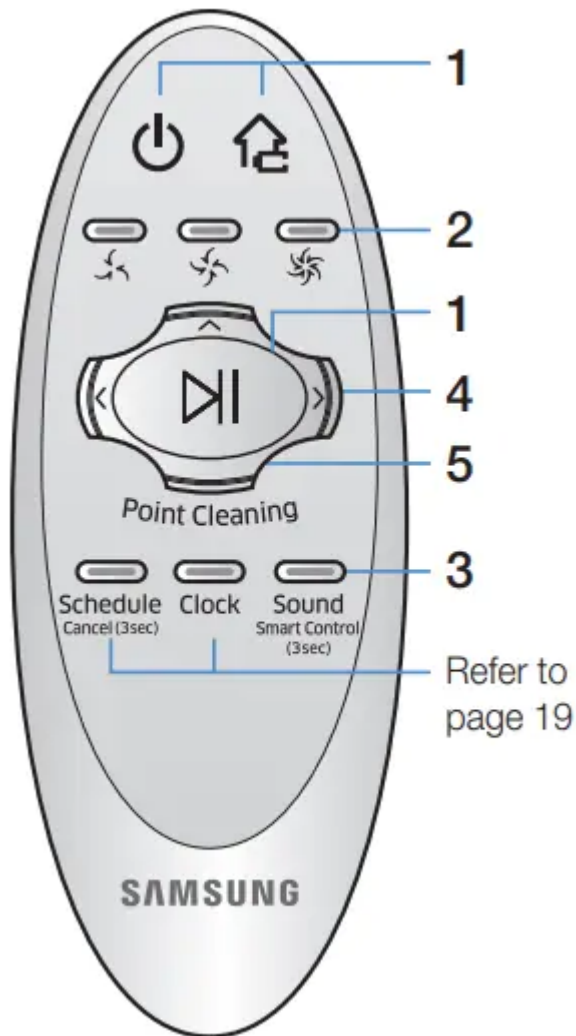
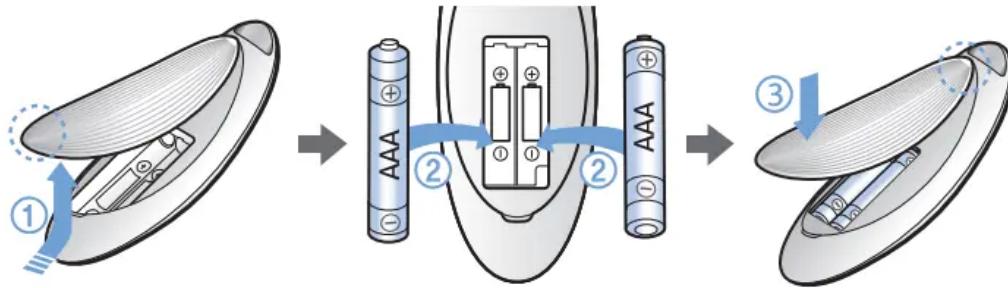

## Inserting batteries

Open the battery cover by lifting it up while pressing the locking tab and insert the batteries as shown in the illustration. Then, close the cover until it clicks into place.



## 4 Manual clean mode & Direction control



	Select to move forward
	Select to turn left
	Select to turn right

\* Moving backward is not available.

### 5 Point cleaning

You can use the remote control to point and clean the desired spot while the pOWERbot is in cleaning process.

point the red light on the floor within 1 m around pOWERbot's location.

Press and hold the Point cleaning button to move the red light to the desired spot. The POWERbot will follow the light while cleaning.

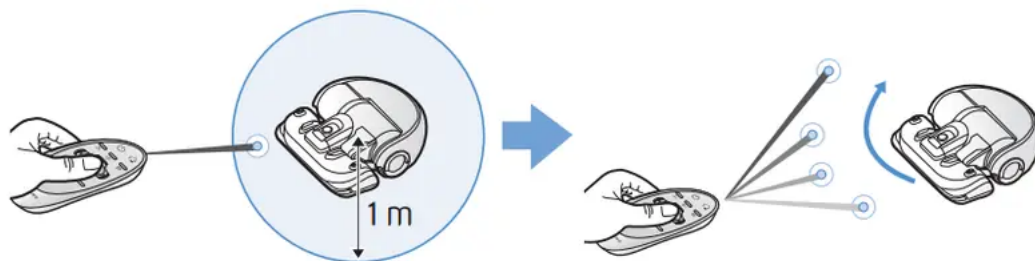

### Operating distance of the remote control

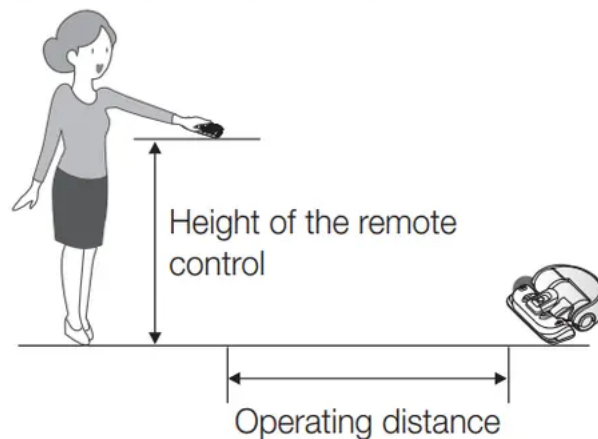

<b>Height of the remote control</b>	1 m	1.5 m
<b>Operating distance</b>	About 2 m	About 2.5 m

### Name of each part

#### Top

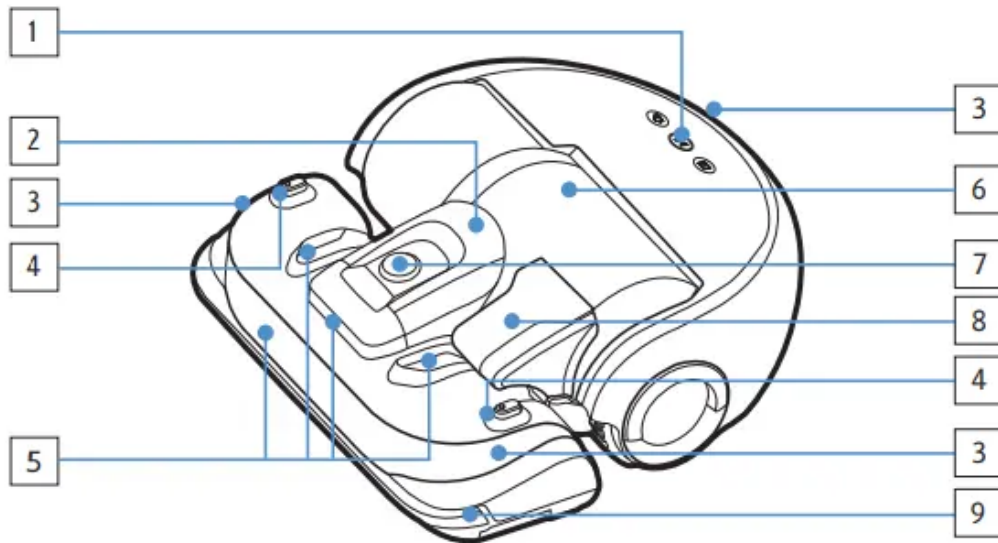

1. Display panel
2. Dustbin holder
3. Remote control signal receiver
4. Virtual guard sensor
5. Obstacle sensor
6. Dustbin
7. Camera
8. Dustbin handle
9. Bumper sensor

#### Bottom

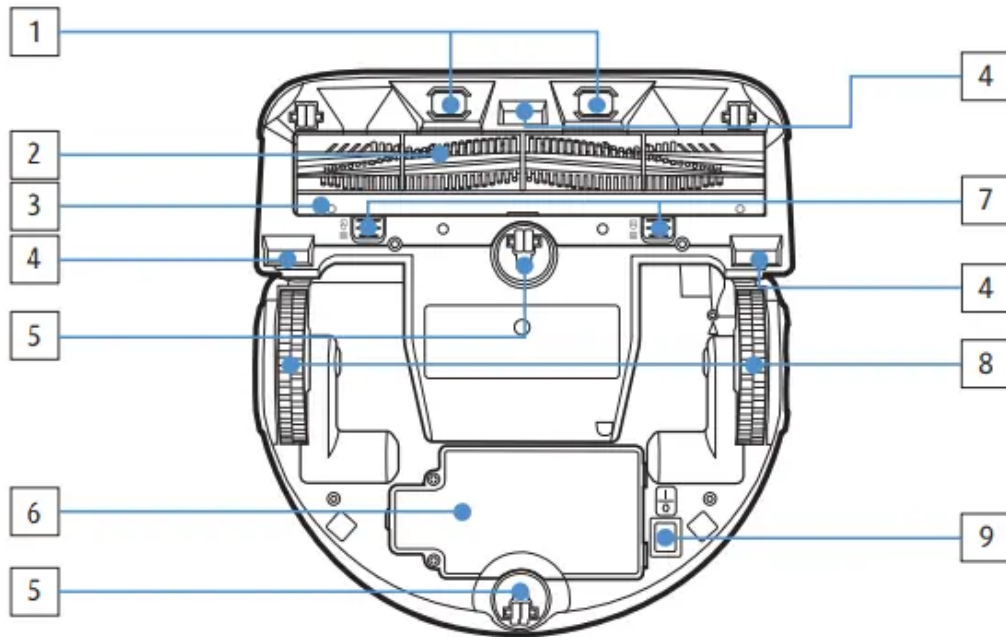

- 1. Charge pins
- 2. Pet brush
- 3. Pet brush cover
- 4. Cliff sensor
- 5. Roller
- 6. Battery cover
- 7. Pet brush cover button
- 8. Driving wheel
- 9. Emergency switch

**Display panel**



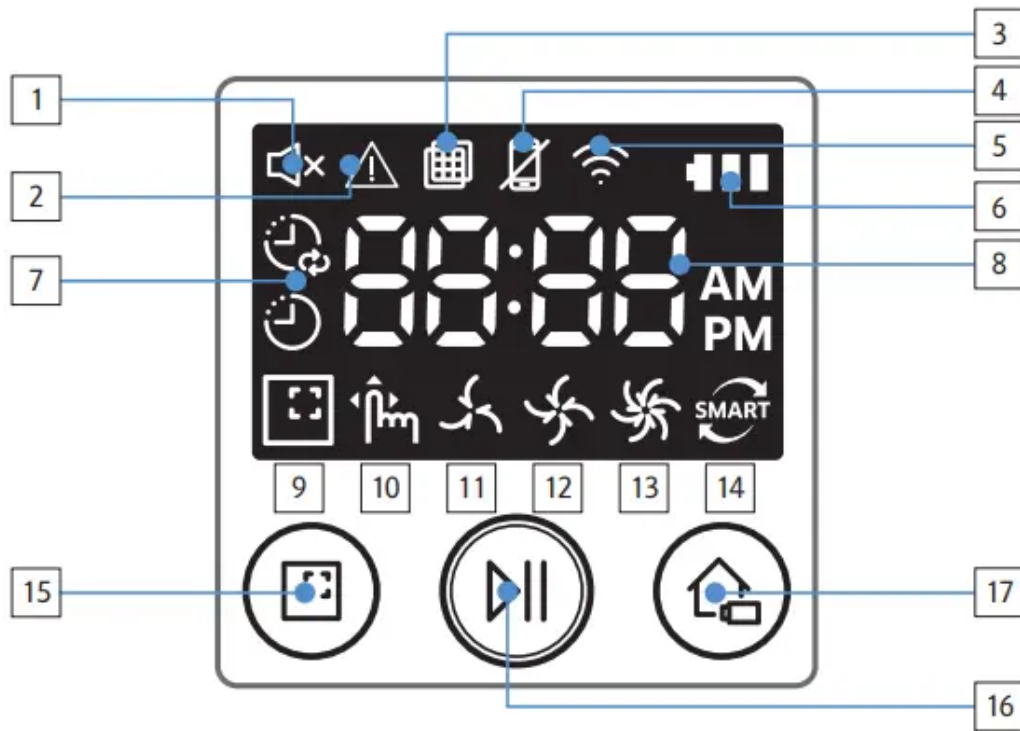

1. Mute
2. Information Indicator
3. Filter inspection
4. Smart Control Off/On indicator
5. Wi-Fi
6. Battery indicator
7. One-time/Daily schedule
8. Number display
9. Spot clean mode
10. Manual clean mode
11. Quiet mode
12. Normal mode
13. Max mode
14. Dust sensor
15. Spot cleaning button
16. Start/Stop button
17. Recharging button

## Setting time/schedule

Only Auto clean mode can be scheduled.

**Setting the time:** You must set the current time before using the One-time/daily schedule function.

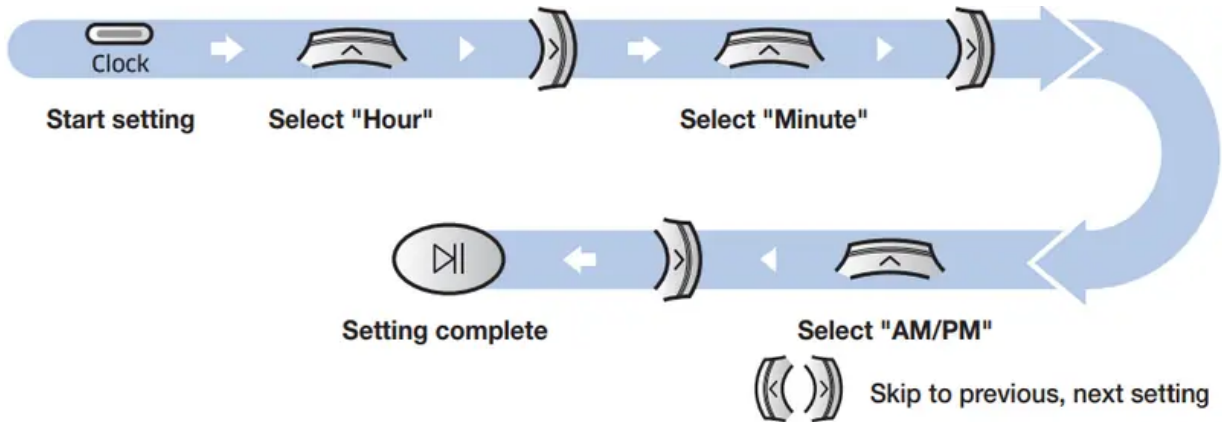

**Setting the schedule:** You can set/cancel the schedule only when the POWERbot is docked in the docking station.

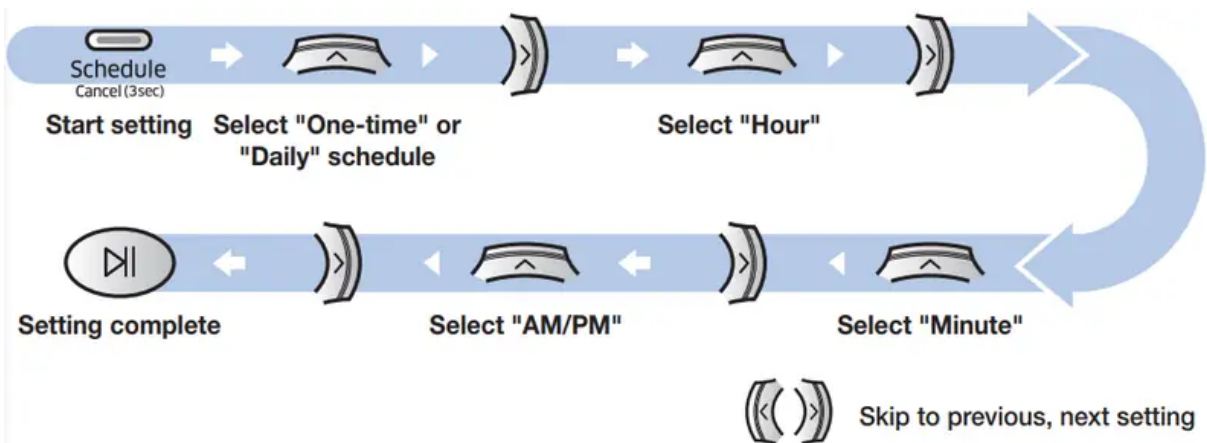

**Cancelling during setup:** The setting will be canceled automatically if there's no input for 7 seconds.

### Cancelling One-time/Daily schedule

When both One-time/ Daily schedule is set	Schedule Cancel (3sec) →  or  Schedule Cancel (3sec) →  or  Schedule Cancel (3sec)
When either one of One-time or Daily schedule is set	Schedule Cancel (3sec) Press for 3 sec.

## Cleaning and maintaining

You must turn off the emergency switch before cleaning the POWERbot.



### Cleaning the dustbin

Clean the dustbin when filter inspection indicator (  ) turns on or if there's too much dust in the dustbin.

1. Remove the dustbin

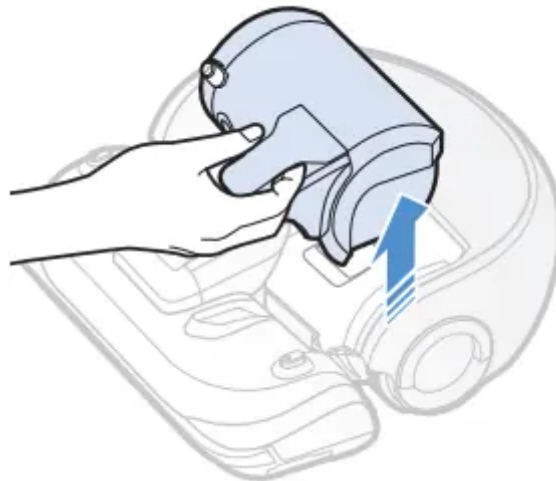

2. Remove the dustbin cover



3. Remove dust in the dustbin and cyclone unit



4. Detach the cyclone unit from the dustbin cover, and then wash the dustbin and the filter

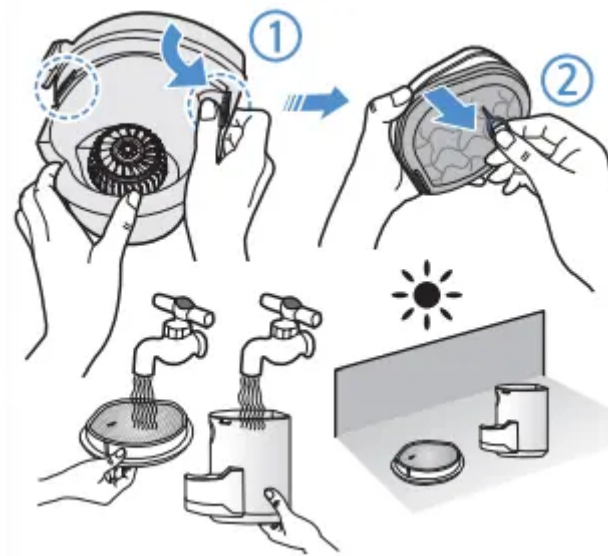

5. Reassemble the dustbin

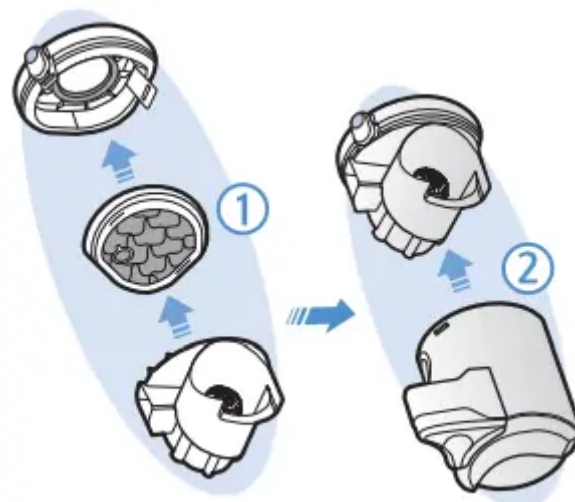

6. Reinsert the dustbin into the main body until it clicks

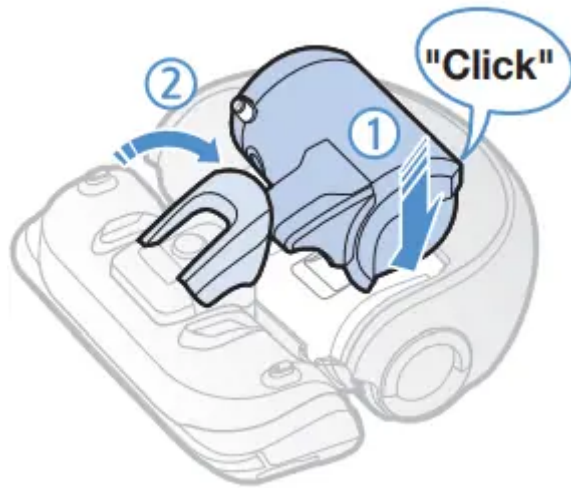

### Cleaning the sensors and the camera

Lightly wipe with a soft cloth. Do not use water or cleaning solutions.

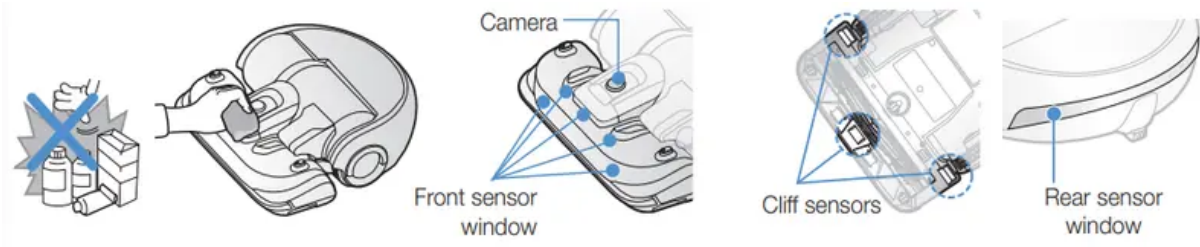

### Cleaning the Pet brush

1. Remove the Pet brush cover

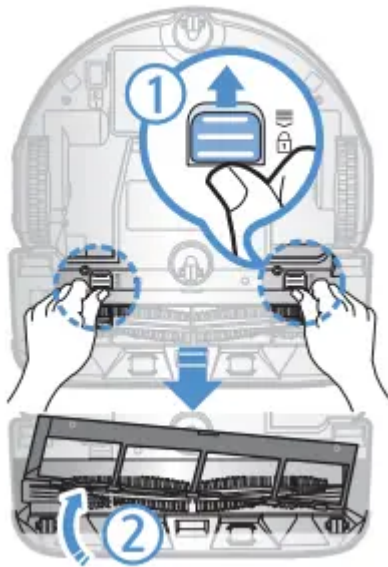

2. Remove the Pet brush

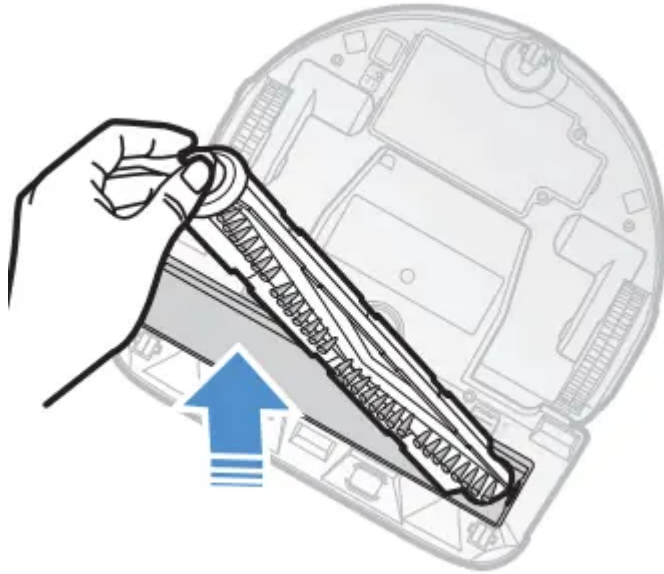

3. Clean the Pet brush



4. Reassemble the Pet brush

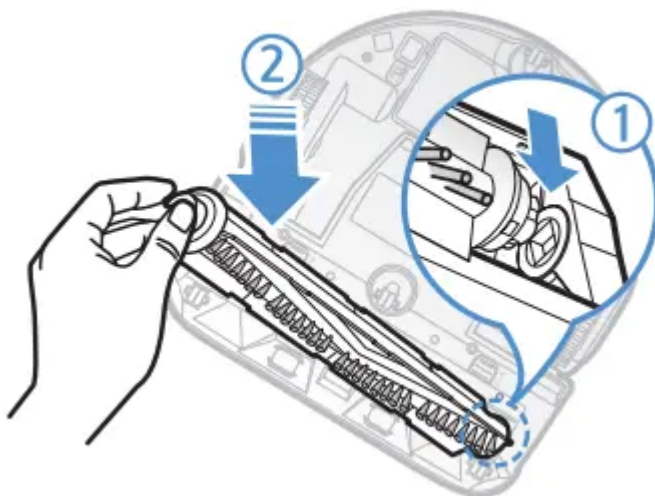

## 5. Reassemble the Pet brush cover

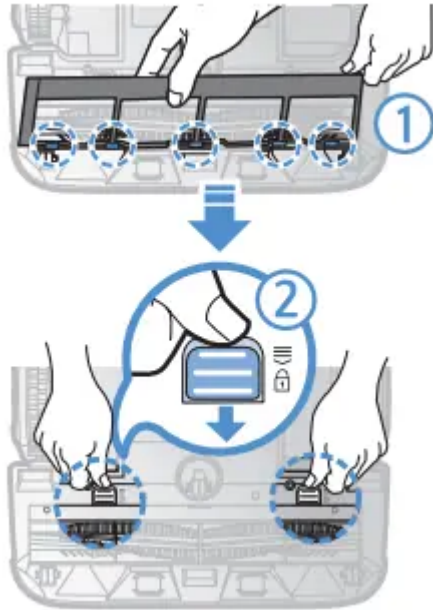

## Cleaning the Driving wheel

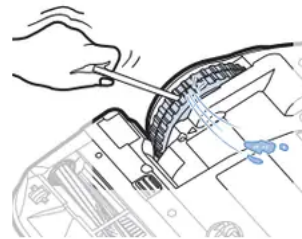
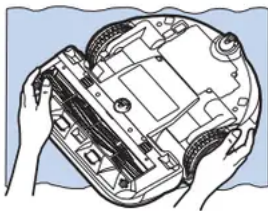

1. Put a soft cloth on the floor and place POWERbot upside-down.
2. Use a blunt rod or tweezers to remove the foreign matters.

## Samsung Smart Home App

### Preparing the network





#### Setting up the wireless router

- This product supports only DHCP(Dynamic Host Configuration Protocol). Please check if the DHCP server option function of a wireless router is activated.
- The supported types of authorization/encryption of the wireless router are WEP-OPEN, WPA-PSK/TKIP and WPA2-PSK/AES 801.11n.
  - WPA2-PSK/AES is recommended to be used.
- The quality of connection of the wireless network may be influenced by the surrounding wireless environment.

- When your Internet service provider has permanently registered an MAC address (a unique identification number) of your PC or modem, your POWERbot may be unavailable to be connected to the Internet. Ask your Internet service provider about the procedure to connect an apparatus other than a PC to the Internet.
- If your internet service provider requires your ID or password to connect to the internet, your POWERbot may not be able to connect to the internet. In this case, you must enter your ID or password when connecting to the internet.
- The connection to the Internet may be impossible because of issues of firewall. Ask your Internet service provider for resolving the issue.
- Some wireless routers may convey an abnormal Domain Name Server (DNS) address even if the Internet is not connected. In this case, inquire the provider of the pertinent wireless router and your Internet service provider.
- If you still cannot connect to the Internet even after trying the procedure informed by your Internet service provider, please ask an agency or service center of Samsung Electronics.

#### Note

- Please refer to the user manual of the pertinent wireless router without access problems.
- Samsung POWERbots support only Wi-Fi 2.4 Ghz.
- Samsung POWERbots support the communication protocol of the methods of IEEE 802.11b/g/n and Wi-Fi Direct. (Samsung Electronics recommends to use IEEE 802.11n.)
- A wireless router with no authorization of Wi-Fi may be unavailable to be connected to the POWERbot.
- When the power is supplied and the POWERbot is docked on the docking station, the POWERbot will be connected to the server and then check if there is software updates. If there is the latest software, it will be automatically downloaded and updated.
- If “UP” is displayed on the display panel while the POWERbot is charging, it means that the update is in progress. Please wait for completing the rebooting.
- If the product registration is not done, please follow the following instructions:
  - Refer to the popup message and retry the registraion procedure.
  - Check if the UPnP option of the wireless router is available and retry the registration procedure.
  - Check if the operating mode of the wireless router is a router mode and retry the registration procedure.
  - If you have more than two POWERbot, turn off the others to register the one. The connection must be one to one.

- If there is a wireless router which has the same SSID around your router, a normal registration cannot be guaranteed.
- Set a unique SSID and password for the wireless router and then register the product.
- Samsung Smart Home Service does not guarantee a normal operation under firewall environment.
- If the POWERbot and smart phone are not connected to the same wireless router, response delay may occur according to network environment.
- Smart control and Wi-Fi indicator
  -  On : Smart control is locked. (Only the remote control is available.)
  -  Off : Smart control is allowed.
  -  Off : The POWERbot is connecting to the wireless router.
  -  On : The POWERbot is connected to the wireless router.

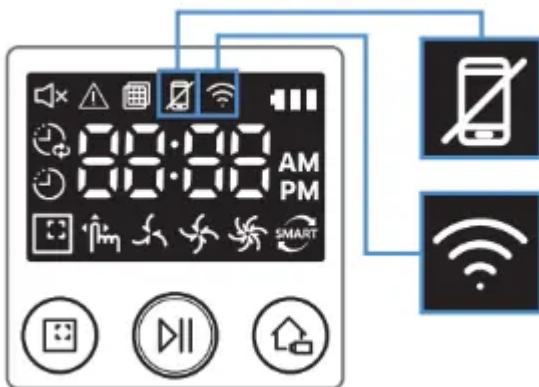

- If Smart control is locked, you cannot use Samsung Smart Home App.

## Using the Samsung Smart Home app

### Creating your Samsung account

If you want to use the Samsung Smart Home app, please register your Samsung account in Samsung account app.

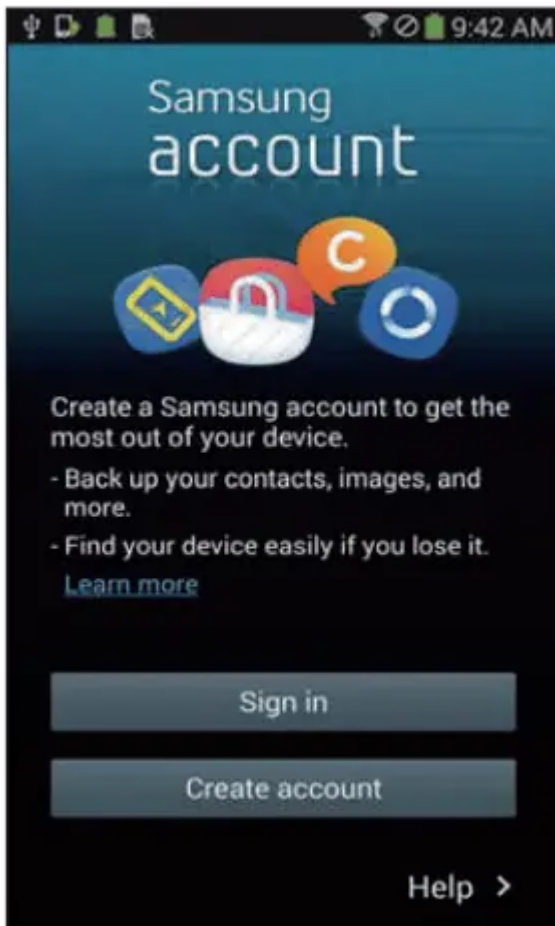

#### Note

- If you do not set auto-login to the Samsung Smart Home app and run the app, the screen of Samsung account appears one time at first.
- If you are a user of a Samsung smart phone, register your Samsung account in the settings of the smart phone, and then the automatic login gets set without any other login processes, and you can use the Samsung smart home app immediately.

#### Downloading Samsung Smart Home app

You can download the Samsung Smart Home app by searching for “Samsung Smart Home App” at the Google Play Store, Samsung Galaxy Apps and Apple App store.

#### Note

- Samsung Smart Home apps are compatible with selected Samsung Galaxy S and Samsung Note series devices. support Android™(2) 4.0 (since Galaxy S2) or higher and iOS7 or higher
  - Application must be downloaded. Internet connection required. Data changes may apply.
  - Android is a trademark of Google Inc

- The UI of Samsung Smart Home App may change without advance notice for improvement of product use and performance.

## Main screen

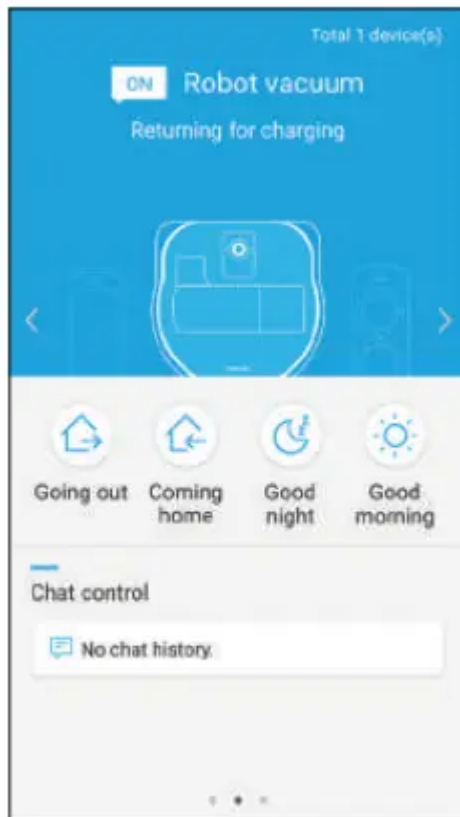

- Select the Robot vacuum icon on the main screen, and you can move to the POWERbot control screen.
- You can control your smart home appliances made by Samsung Electronics by Going out, Coming home, Good night, and Good morning icons.
- Home view function is not supported for a POWERbot.

## User menu screen

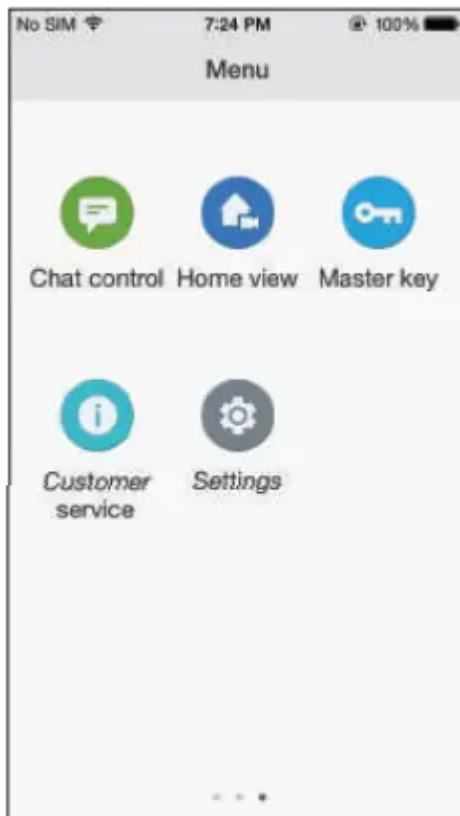

- You can control the smart home appliances made by Samsung Electronics with Chat control and Master key functions.

<p style="text-align: center;"><b>Chat control</b></p>	<ul style="list-style-type: none"> <li>• You can control the smart home appliances or check about the status of them conveniently.</li> </ul>
<p style="text-align: center;"><b>Master key</b></p>	<ul style="list-style-type: none"> <li>• You can control several home appliances at once using the master keys(Going out, Coming home, Good night, Good morning).</li> </ul>
<p style="text-align: center;"><b>Customer service</b></p>	<ul style="list-style-type: none"> <li>• You can see the manual of the product.</li> <li>• When a product is out of order, you can consult with our customer center and request for an after-sales service.</li> </ul>

### Controlling POWERbot

When accessing the Samsung Smart Robot vacuum app, the control screen will appear.

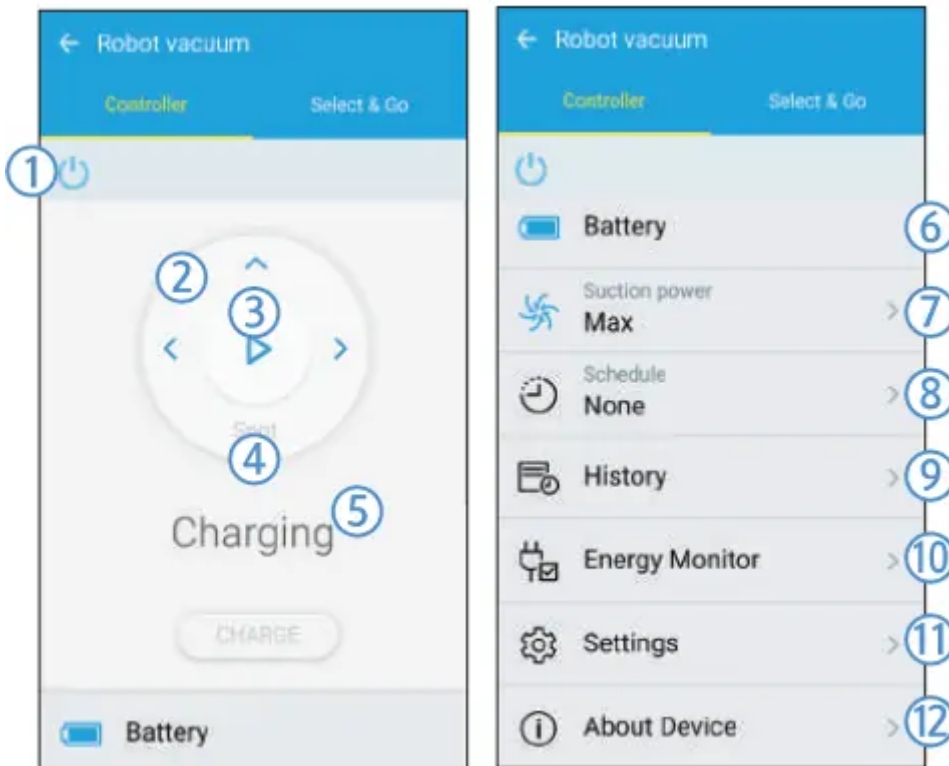

1. Power on/off
2. Manual clean mode and Direction control (forward movement, left turn, right turn)
3. Auto clean mode start/stop
4. Spot clean mode
5. Current status indicator
6. Battery status
7. Suction power
8. Schedule (You can set the desired time for each date.)
  - The POWERbot operates by synchronizing the set time in the network.
9. Cleaning history check
10. Energy monitor (Displays the power consumption of the POWERbot.)
11. Options (Settings, Customer Service)
12. Device information

**Note** A scheduled cleaning runs only when the POWERbot is docked on the docking station.

### Using Select & Go

A feature that allows the user to select and clean specific areas using the Samsung Smart Home app.

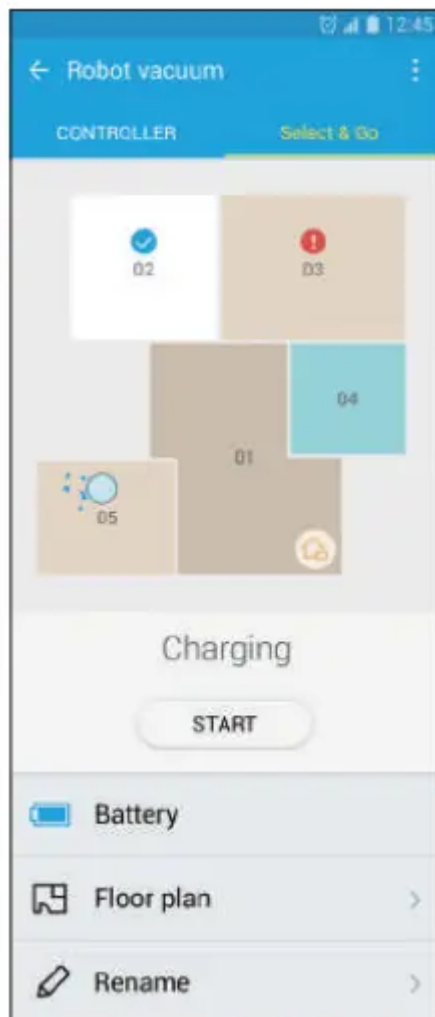

## 1. Cleaning Map and Cleaning Floorplan

- Cleaning Map represents the areas the POWERbot moved while cleaning.
- Cleaning Floorplan is an artificially delineated representation of Cleaning Map.

## 2. Area Cleaning

- Includes configurable labels for each of the areas.
- Select areas to clean and tap Start to clean.
- Each area's status is indicated on the map.

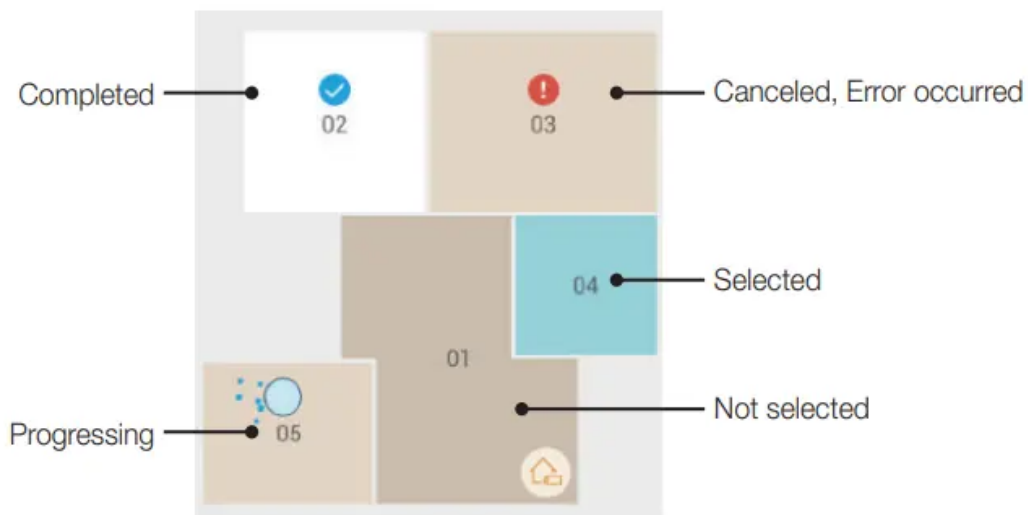

## Note

- Precautions for Setting Cleaning Floorplan
  - Place the charging station flush to a wall in an open area.
  - Remove obstacles from the floor (rugs, towels, chairs, mats, toys, etc.).
  - Remove obstacles along the paths to the areas to be included in the floorplan.
  - If possible, close all doors with high sills (veranda, balcony, etc.).
  - Ensure the areas to be included in the floorplan are well illuminated.
- Cautions for Using Area Cleaning
  - Area Cleaning can commence only when Powerbot is being charged.
  - Area Cleaning will not function properly if the actual station's location and orientation do not match the location and orientation in the floorplan selected.
  - Area Cleaning feature may not function properly depending on the state of the floor and/or placement or obstacles in the concerned area.
  - Areas on a floorplan are areas artificially delineated by Powerbot and may not include all the rooms.
  - Map generation and Select & Go may not be available on areas covered in some carpets.
  - There may be the difference between floorplans according to status of Powerbot even the environment is same.
  - The user can select and use the desired floorplan by Floor plan menu.

# Notes and cautions

## Charging

### Notes

- If the battery overheats during charging, it may take longer to charge.
- When automatic charging is not working, please check the followings.
  - Turn the emergency switch (on the bottom of POWERbot) off and on again.
  - Unplug the docking station's power plug and then plug it back on.
  - Unplug the docking station, and then check whether there is any foreign matter on the charging pins. If there is, clean the POWERbot and the charging pins of the docking station with a dry cloth or rag.
  - Check for any obstacles such as reflective objects, chairs, etc. near the docking station.
- If POWERbot is left detached from the docking station, the battery will drain naturally.
  - Try to keep the POWERbot in the docking station so it can charge continuously when not in use. However, you should turn off the emergency switch and leave the docking station unplugged if you plan to be out of your house for long periods of time such as when you go on vacation, etc.

## In use

- The POWERbot may get caught on thresholds, etc. during cleaning.
  - To restart operation, shut off the emergency switch, move the POWERbot to an area where it can move easily, and then turn on the power again.
- The POWERbot cannot completely clean areas it cannot enter, such as corners, between the wall and sofa, etc.
  - Please use another cleaning tool to clean them regularly
- The POWERbot cannot vacuum clumps of dirt, so some may remain on the floor after cleaning.
  - Please use another cleaning tool to clean them regularly.
- If the battery becomes low during Auto clean mode, POWERbot will recharge and finish cleaning the remaining area after recharging. (Repeat cleaning frequency: 1 time)
- You cannot select and have the POWERbot execute Spot clean mode while it is charging.
- If you press the Manual clean / Point cleaning button while the POWERbot is charging, the POWERbot will detach itself from the docking station and then go into standby mode.

- Do not lie down around the POWERBOT that is running.
  - Your hair may be caught in the Pet brush, resulting in physical injury

## Cleaning and maintenance

### Notes

- If you washed the dustbin and filter with water
  - Dustbin: Completely wipe out the water.
  - Filter: Completely dry it in the shade before using.
- When cleaning the auto shutter tool, do not pull the auto shutter tool out too hard.

### Caution

- Watch your fingers when attaching or detaching the filter, since they may get stuck in the dustbin's intake.
- To avoid blockages by foreign matter, do not let the POWERbot vacuum up toothpicks, cotton swabs etc.
- If it is difficult to remove foreign matter from the brush, contact an authorized Samsung service center.
- Since the Pet brush removes dirt from the floor during cleaning, foreign matters such as thread, long hair, etc. may get caught in it. Therefore check and clean it regularly.

## About the battery

- Purchase batteries at authorized Samsung centers and check for the Samsung symbol ( ) on the battery. Confirm that you have the correct model battery before purchasing.
- This battery is exclusively for the Samsung Electronics POWERbot. Do not use it for any other product.
- Do not disassemble or modify the battery.
- Do not throw the battery out in a fire or heat it up.
- Do not connect any metallic object to the charging contacts (+, -).
- Store the battery indoors (at 0 °C~40 °C).
- If the battery malfunctions, do not disassemble it yourself. Contact your nearest Samsung service center.
- Battery charging time and usage time may decrease the more the battery is used. If the battery's lifespan has been exceeded and it no longer recharges or functions properly, have it replaced at a Samsung service center.
- The battery warranty period is 6 months from the date of purchase.

## About the IrDA sensor

### Caution

- The infrared signal transmission may not be smooth in locations exposed to halogen lamps or in outdoor locations.
- The POWERbot uses 3 types of infrared devices and a device may not work in front of another device with a higher priority.
  - Infrared signal Priority: Remote control > Virtual guard > Docking station
- When controlling POWERbot with the remote control, POWERbot may cross the invisible barrier set by the Virtual guard and enter the area you don't want it to enter, since remote control's signal has a higher priority.
- Different infrared signals may interfere with one another and cause malfunction to the devices if they are used together in a small space or in a close distance.
- Install the Virtual guard away from the docking station as auto charging may be interrupted if the Virtual guard is near the docking station.
- If more than one POWERbots are used simultaneously, they may malfunction due to interference of the infrared signals.

## Information codes

1. Below information codes appear on the display panel
2. Turn off the emergency switch and check the below instructions and take appropriate action
3. Information code will disappear when you turn on the emergency switch

Information codes	Checklist
	<p><b>The POWERbot is caught, stuck or trapped while moving around.</b></p> <ul style="list-style-type: none"> <li>▶ Turn off the emergency switch and move the POWERbot to another area.</li> </ul>
C 01	<p><b>Foreign matter caught in the pet brush.</b></p> <ul style="list-style-type: none"> <li>▶ Turn off the emergency switch and remove the foreign matter from the Pet brush.</li> </ul>
C 02	<p><b>Foreign matter caught in the left Driving wheel.</b></p> <ul style="list-style-type: none"> <li>▶ Turn off the emergency switch and remove the foreign matter from the Driving wheel.</li> </ul>
C 03	<p><b>Foreign matter caught in the right Driving wheel.</b></p> <ul style="list-style-type: none"> <li>▶ Turn off the emergency switch and remove the foreign matter from the Driving wheel.</li> </ul>
C 05	<p><b>Bumper sensor needs to be checked.</b></p> <ul style="list-style-type: none"> <li>▶ Turn off the emergency switch and turn it back on.</li> <li>▶ When information code does not disappear, check if there's any small foreign matter between the bumper and the main body. If there is, pull the bumper slightly and remove the foreign matter.</li> </ul>
C 06	<p><b>Foreign matter accumulated on the obstacle sensor.</b></p> <ul style="list-style-type: none"> <li>▶ Turn off the emergency switch and clean the front and rear sensor with a soft cloth.</li> </ul>
C 07	<p><b>Foreign matter accumulated on the cliff sensor.</b></p> <ul style="list-style-type: none"> <li>▶ Turn off the emergency switch and clean the cliff sensor with a soft cloth.</li> </ul>

## Troubleshooting

Symptom	checklist
<p><b>The POWERbot is not working at all.</b></p>	<ul style="list-style-type: none"> <li>▶ Check if the emergency switch is on.</li> <li>▶ Check if all the icons are displayed on display panel.</li> <li>▶ Check if the battery of POWERbot is depleted.</li> </ul> <p>- When "Lo" is displayed, carry POWERbot to the docking station to charge it.</p> <ul style="list-style-type: none"> <li>▶ Replace the batteries (AAA type) when the remote controller is not working.</li> </ul>
<p><b>The PoWeRbot is stopped during cleaning process.</b></p>	<ul style="list-style-type: none"> <li>▶ When "Lo" is displayed on the display panel, carry POWERbot to the docking station to charge it.</li> <li>▶ When POWERbot is stuck by the obstacles such as cord, threshold etc, pick it up to remove it from the obstacle.</li> </ul> <p>- If any fabrics or strings are caught in the drive wheel, turn off the emergency switch and remove the fabrics or strings before using it again.</p>
<p><b>Suction power is weak.</b></p>	<ul style="list-style-type: none"> <li>▶ If the "Filter inspection indicator" is on, turn off the emergency switch and clean the dustbin.</li> <li>▶ When there's too much dust in the dustbin, suction power may get weakened. Turn off the emergency switch and empty the dustbin.</li> <li>▶ If the intake (on bottom of POWERbot) is blocked by foreign matters, turn off the emergency switch and remove foreign matter from the intake.</li> <li>▶ When noise suddenly increase, turn off the emergency switch and empty the dustbin.</li> </ul>
<p><b>the PoWeRbot cannot find the docking station.</b></p>	<ul style="list-style-type: none"> <li>▶ Check if there's power failure or whether the power plug is unplugged.</li> <li>▶ Remove any obstacles around the docking station that may disturb POWERbot from returning to the docking station.</li> <li>▶ When there's foreign matters on the charge pins that affects charging, clean the foreign matter.</li> </ul>



<p><b>the PoWeRbot passes through the Virtual guard.</b></p>	<ul style="list-style-type: none"> <li>▶ If the batteries are depleted, replace them. (2 type D (LR20) batteries)</li> <li>▶ If the lamp is off, check if the Virtual guard is turned off and turn it on.</li> </ul>
<p><b>the PoWeRbot suddenly cleans diagonally.</b></p>	<ul style="list-style-type: none"> <li>▶ Check if the docking station is installed along the grain of wooden floors or tiles.</li> <li>▶ It may clean in diagonal direction for moving to another area in shortest route, or it made contact with any obstacles in that angle, or if it was charged at the charged at an angle, or grain of the wooden/tile floor is in that direction.</li> </ul>
<p><b>Point cleaning is not working.</b></p>	<ul style="list-style-type: none"> <li>▶ If you point the red light directly on POWERbot, it may not move to desired direction.</li> <li>- Point the red light on the floor within 39 in (1 m) around POWERbot. * Do not use the point cleaning under direct sunlight, bright light or on dark floors.</li> </ul>
<p><b>"Filter inspection indicator" is on even after the dustbin has been emptied.</b></p>	<ul style="list-style-type: none"> <li>▶ Use POWERbot after turning off the emergency switch and then turning it back on.</li> <li>▶ Empty the dustbin again and re-clean the filter thoroughly.</li> </ul>
<p><b>PoWeRbot moves around at the same place.</b></p>	<ul style="list-style-type: none"> <li>▶ Dust sensor mode is on.</li> <li>- The dust sensor mode is on by default. When the POWERbot passes through a dusty area, it moves around that area to focus on cleaning.</li> <li>▶ POWERbot moves around an area and the "DUST" is on the display panel even though there's no dust at the surrounding area.</li> <li>- Check if foreign matters are caught between the dustbin and Pet brush and then remove them.</li> </ul>



<p><b>PoWeRbot does not clean a certain area.</b></p>	<p>▶ Check if the docking station is installed near a narrow passage or door, and reinstall it in the other areas.</p> <p>- If the docking station is installed near a narrow passage or door, the POWERbot cannot pass through the passage or doorsill.</p>
<p><b>The battery usage time of the Virtual guard is too short.</b></p>	<p>▶ Check if you're using manganese drycell batteries and replace the batteries with new ones. (2 type D (LR20) batteries)</p>
<p><b>I have installed the Samsung Smart Home app, but, the PoWeRbot fails to be connected.</b></p>	<p>▶ You can use the product after connecting the wireless router and the POWERbot through Easy-Setup according to the procedure.</p>
<p><b>I fail to log into the Samsung account.</b></p>	<p>▶ Check your ID and password on the screen of the Samsung account.</p>
<p><b>There appears a message saying there is a failure during easy-Setup.</b></p>	<p>▶ You may have failed temporarily due to the distance from the wireless router or other obstacles. Please try again after a while.</p>
<p><b>The products do not work even though the smart phone is normally connected to the PoWeRbot.</b></p>	<p>▶ Turn off the Samsung Smart Home app and then run it again, or disconnect the smart phone from the wireless router and then connect it again. Or turn off the power supply of the POWERbot, turn it on, wait for a minute or longer, and then run the Smart Home app again.</p>
<p><b>the functions of the Samsung Smart Home App do not work.</b></p>	<p>▶ Check if the Smart control blocking function of the POWERbot is set. (When the Smart control is locked, the Wi-Fi indicator is turned off.)</p>
<p><b>the Samsung Smart Robot Vacuum App fails to get started.</b></p>	<p>▶ Check if the POWERbot is connected to the wireless router.</p>
<p><b>PoWeRbot is not connected to Wi-Fi.</b></p>	<p>▶ Check the setting status of the wireless router.</p>



**Location recognizing function  
does not operate.**

- ▶ Operate the POWERbot again near the area where it stopped previously.
- ▶ If the POWERbot does not recognize the surrounding environment or starts the cleaning at the area more than 1 m around where it stopped, the searching may be difficult.



# Specifications



<b>Classification</b>	<b>Item</b>	<b>Detail information</b>		
<b>Mechanical specifications (POWERbot)</b>	Size (Depth x Height x Length)	378 mm x 135 mm x 362 mm		
	Weight	4.9 kg		
	Sensor	Ceiling shape recognition (Visionary mapping plus TM)		
	Button type of POWERbot	Touch type		
<b>Power specifications</b>	Power voltage	100 - 240 V~, 50 Hz / 60 Hz		
	Power consumption	250 W (Max mode)		
	Battery specifications	Lithium ion 21.6 V / 97.2 Wh		
<b>cleaning</b>	Charging type	Automatic charging/Manual charging		
	Cleaning mode	Auto, Spot, Manual		
	Scheduling function	One-time schedule, Daily schedule		
	Charging time	Approximately 240 minutes		
	Cleaning time (On the basis of hard floor)	Max mode	Approximately 30 minutes	
		Normal mode	Approximately 60 minutes	



		Quiet mode	Approximately 90 minutes
--	--	------------	--------------------------

**Warning**

This content is compiled from multiple sources and is provided for reference purposes only. It may not be complete or fully applicable to all situations. If you are unable to resolve your issue, please contact the product manufacturer or an authorized service provider for official support.

