

## USING THE PAN ON ITS OWN

### Preparing the food

Do not leave the measuring spoon inside the pan while cooking food.

- Open the lid - fig.1.



- Remove the spoon inside the pan.
- Prepare your ingredients as indicated in the recipe book or these instructions.
- Place the food in the cooking pan, distributing it evenly, making sure that you respect the maximum quantity (see cooking tables p. 12 to p. 14)

- Add the oil to the food with the spoon (1 Actifry Genius spoonful = 14 ml) - fig.13 distributing it evenly.

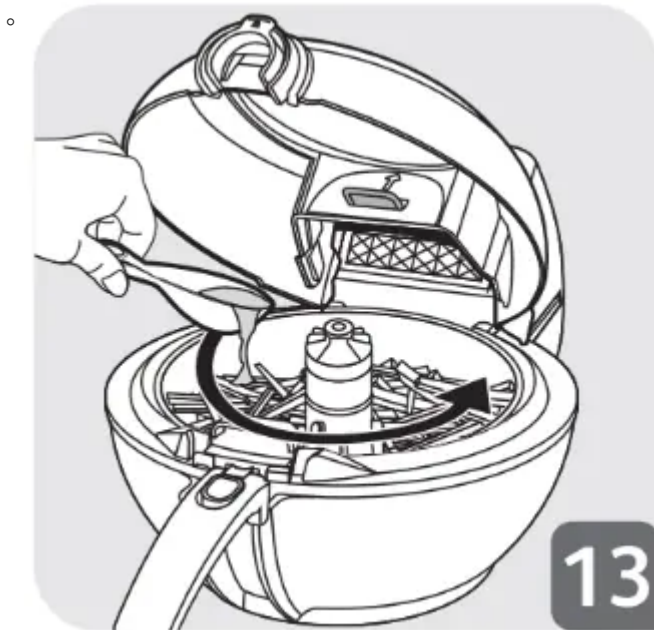

- Unlock the handle and push it right back into its housing - fig.14.

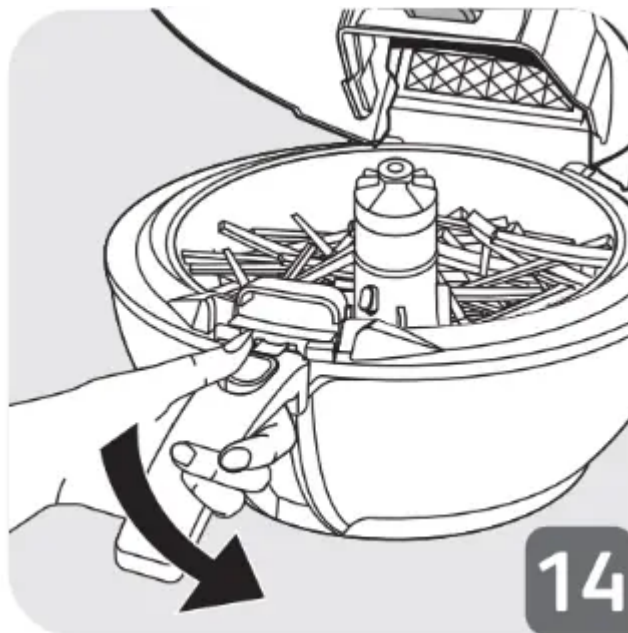

- Close the lid - fig.15.

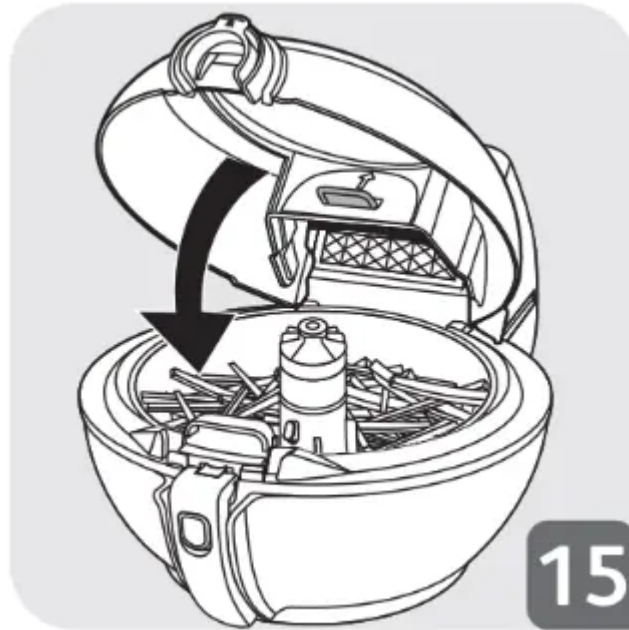

### **Start cooking**

- Plug the appliance into an electrical socket outlet - fig. 16. The appliance will emit 2 beeps and the screen will flashing.

### **2 ways of setting the cooking time:**

#### **Automatic cooking mode:**

The 9 cooking modes automatically adjust the cooking temperature and whether the paddle rotates according to the type of food selected.

- Once you have closed the lid and plugged in the appliance the icon  flashes on the screen.



- To select the cooking mode press the + button until the required mode 1 to 9 is displayed - fig.18.



- Press start key - fig.19.

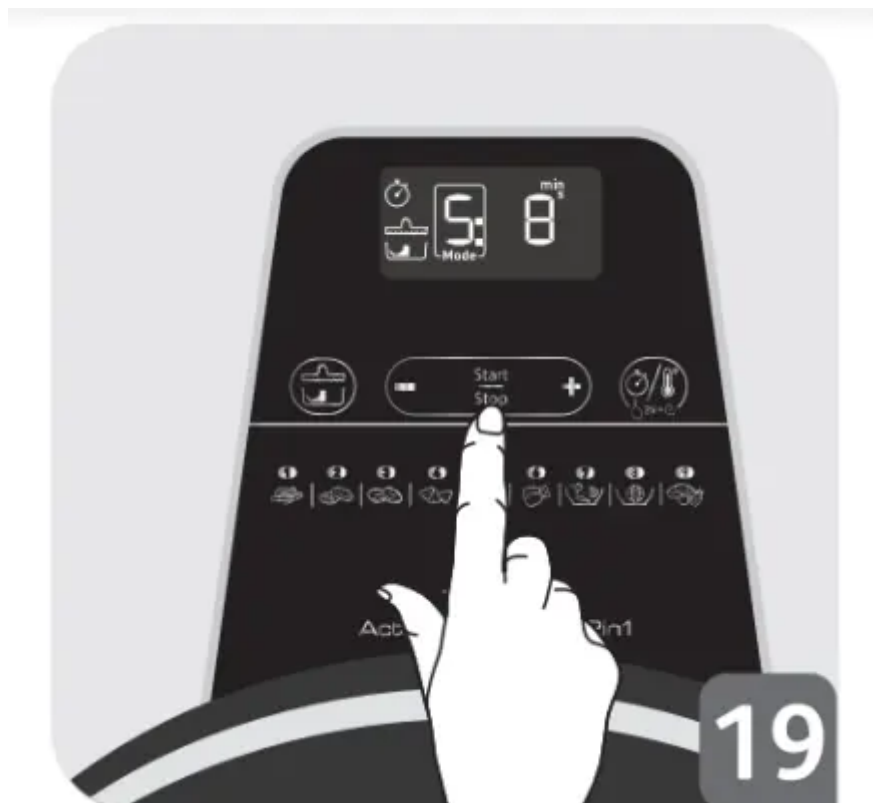

- Adjust cooking time by pressing +/- button. Note: Adjust the cooking time after starting the appliance.
- When using the automatic cooking mode follow the instructions in the recipe book on where to position food in the pan.

**Note:** The paddle does not turn at the beginning of cooking for programs 2, 3, 4, 5, 7, 8 and 9.

- To stop the cooking mode, press the START/STOP key.
- To cancel the cooking mode, continually hold down the START/STOP key for 2 seconds and the screen will display the icon  , '1' for mode and 29 min



1. Chips and fries e.g potato chips, vegetable chips, potato wedges, ...



6 Chicken e.g drumsticks and wings, ...



2. Breaded recipes e.g chicken nuggets, breaded king prawns, ...



7. Wok\* e.g. fried rice with prawns, sautéed beef, stir fry vegetables, ...



3. Battered recipes e.g. battered onion rings, battered calamari rings, ...



8. World food\* e.g lamb tajine, fried noodles with vegetables, ...



4. Spring rolls, samosas and filo pastry snacks





9. Desserts e.g apples and pear compote, coconut clusters, ...



5. Meat and Fish

#### EN Manual mode:

- Set to manual mode by pressing the +/- button until 'M' is displayed.
- Set the cooking time by press the temperature/timer button  and set the cooking time in minutes by using the +/- button (see cooking table p. 12 to p. 14)
- Set the cooking in minutes by using the +/- button (see cooking table p. 12 to p. 14).
- Then set the cooking temperature by pressing the temperature/timer button , and set the temperature required using the +/- button (see cooking table p. 12 to p. 14).
- Press start.

#### NOTE:

- The selected time will be displayed and a minute by minute countdown will begin. Time is selected and displayed in minutes. Only time remaining under 1 minute will be displayed in seconds.

- The appliance can be paused. Simply press START/STOP key. Pressing the START/STOP key will restart cooking.
- The time can be changed at any time during cooking by using the +/- buttons - fig.18.

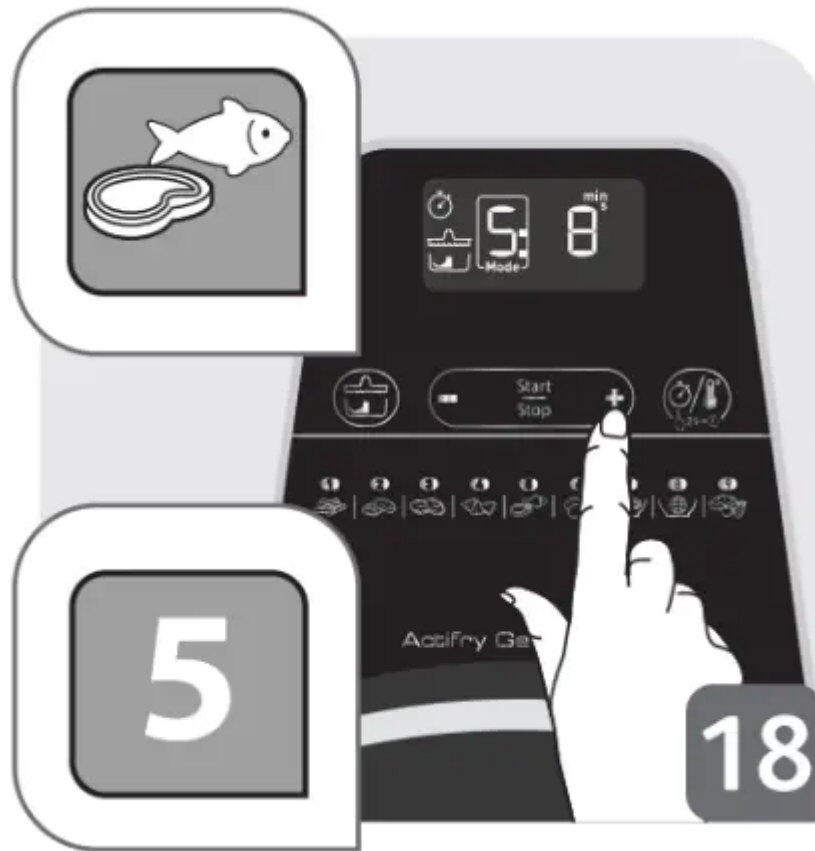

- In the event of an error or to delete the selected time, hold down the START/STOP key for 2 seconds and re-select the time.

### Remove the food

When you open the lid, the appliance stops working. To restart cooking, close the lid and press the START button.

When the lid is left open for over 2 minutes, the appliance will reset.

- Once cooking is completed, the timer beeps.

- Open the lid - fig.22.

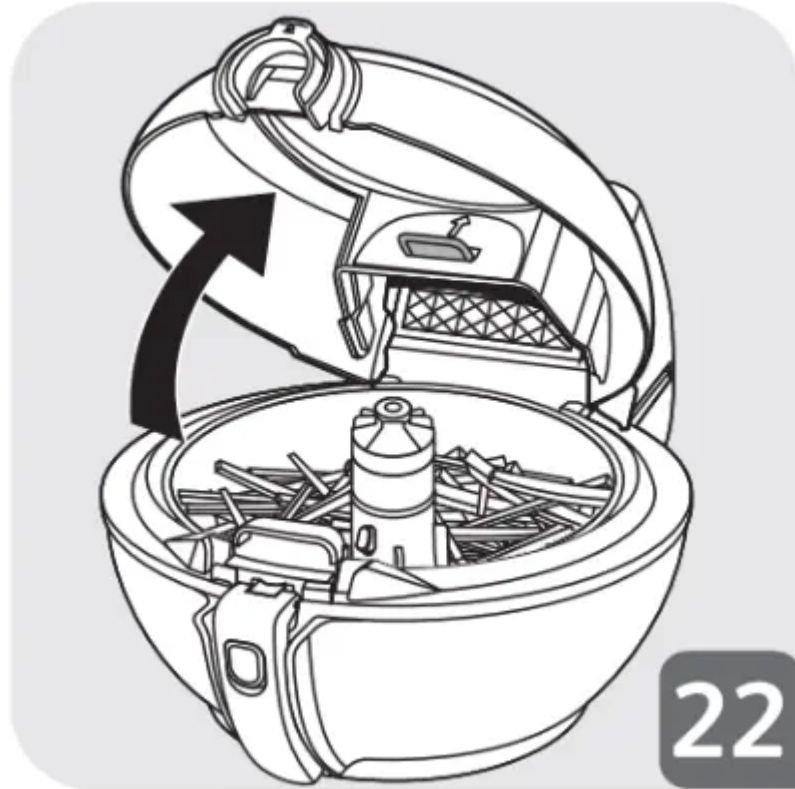

- Lift the handle until you hear a “click” that it locks and take out the cooking pan - fig. 31&32.

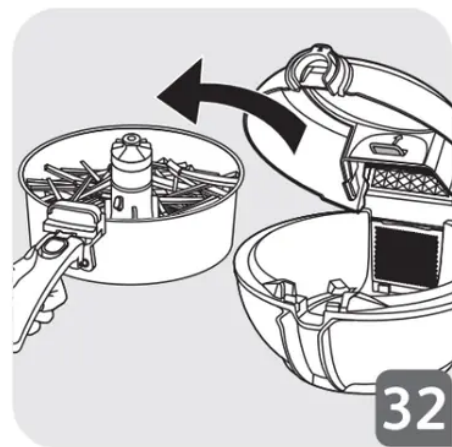
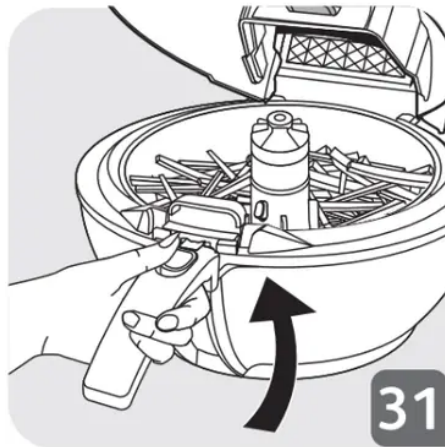

- Serve at once.
- To avoid any risk of burns, do not touch the lid or any part other than the cool touch areas: pan handle and lid opening button.

### **Cooking times FOR PAN ONLY**

The cooking times are given as an approximate guide and may vary depending on the seasonality of the food, its size, the quantities used and individual tastes, as well as the voltage. The amount of

oil indicated may be increased depending on your taste and needs. If you want crisper chips, you can add a few extra minutes to the cooking time.

## Potatoes

	Type	Quantity	Actifry spoons of oil	Cooking mode	Cooking time for the pan (mins)
Fresh chips 10 mm x 10 mm	Fresh (chips)*	750 g	1/2	1	25-27
		1000 g	3/4	1	28-30
		1500 g	1	1	36-38
		1700 g	1	1	42-44
Frozen chips 13 mm x 13 mm	Frozen (chips)**	750 g	None	1	23-25
		1200 g	None	1	36-38

\* Freshly harvested potatoes may require a longer cooking time to obtain a crisper more golden brown result.

\*\* For best results we recommend using frozen chips without any wheat flour batter coating as they tend to give less crisp results and the batter may fall off during cooking (check the ingredient list on the packet for details).

## Meat- poultry

To add a little flavour to your meat, don't hesitate to mix spices in with the oil (paprika, curry, mixed herbs, thyme, bay leaf, etc).

	Type	Quantity	Actifry spoons of oil	Cooking mode	Cooking time for the pan (mins)
Chicken nuggets	Fresh or Frozen	750 g	None	2	10 - 12
	Fresh	1200 g	None	2	13 - 15
	Frozen	1200 g	None	2	15 - 17
Chicken drumsticks	Fresh	4 to 6	None	6	20- 22
Chicken breast (boneless)	Fresh	6	None	6	18 - 20
	Fresh	9	None	6	22 - 24
Meatballs	Frozen	750 g	1	5	14 - 15
	Frozen	1200 g	1 1/2	5	18 - 20

## Rice and Vegetable Dishes

	Type	Quantity	Actifry spoons of oil	Cooking mode	Cooking time for the pan (mins)
Ratatouille*	Frozen	750 g	None	7	14 - 16
	Frozen	1000 g	None	7	23-25
Farmer's stir fry*	Frozen	1000 g	None	6	22-24
Paëlla*	Frozen	650 g	None	Manual: 220°C	12 - 14
	Frozen	1000 g	None	Manual: 220°C	15-17

\* Frozen preparations not available in all countries.

## Fish – shellfish

	Type	Quantity	Actifry spoons of oil	Cooking mode	Cooking time for the pan (mins)
Battered calamari	Frozen	300 g	None	3	10-12
		500 g		3	11-13
King prawns (raw)	Fresh	300 g	None	3	8-10
		450 g		3	8-10

## Vegetables

	Type	Quantity	Actifry spoons of oil	Cooking mode	Cooking time for the pan (mins)
Courgettes	Strips	750 g	1 + 150 ml. water	7	20 - 25
		1200 g	1 + 150 ml. water	7	25-30
Peppers	Strips	650 g	1 + 150 ml. water	7	15 - 18
		1200 g	1 + 150 ml. water	7	20-25
Mushrooms	Quarters	650 g	1	7	10 - 15
		1000 g	1	7	16-18
Tomatoes	Quarters	650 g	1 + 150 ml. water	7	12 - 14
		1000 g	1 + 150 ml. water	7	15-17
Onions	Slices	500 g	1	Manual: 220°C	12 - 14
		750 g	1	Manual: 220°C	18-20

## Fruit

	Type	Quantity	Actifry spoons of oil and sugar	Cooking mode	Cooking time for the pan (mins)
Bananas	Slices	5	1 + 1 of sugar	9	5-6
		7	1 + 1 of sugar	9	5-6
Strawberries	Quarters	1000 g	2 of sugar	9	8-10
		1500 g	2 of sugar	9	10-12
Apples	Halves	3	1 + 1 of sugar	9	8-10
		5	1 + 2 of sugar	9	10-12
Pineapples	Fresh (peeled & cut into pieces)	1	2 of sugar	9	10-12
		2	2 of sugar	9	15-17

## USING THE TRAY ON ITS OWN

### Get your food ready

- Open the lid – fig.1.



- Remove the measuring spoon and removable turn-over ring from the cooking pan.

- Remove the tray – fig.4.

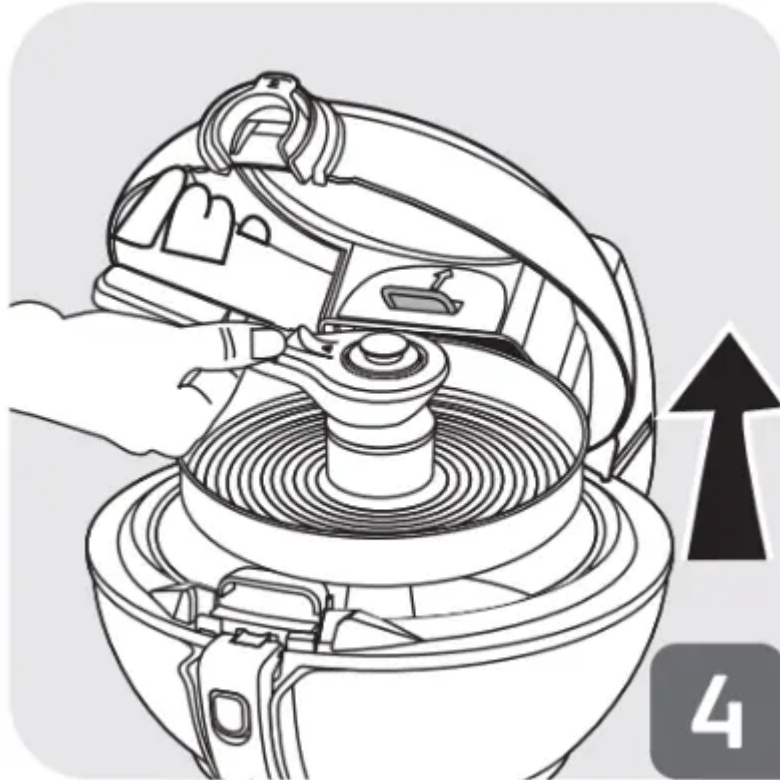

- Place your food on the tray making sure you always keep to the quantities recommended in the cooking tables and/or the recipe book (please see “Cooking table for tray quantities page 17). Never exceed the “MAX” level marker shown on the centre of the tray – fig.23.



- Put the tray back in the appliance using the tray handle - fig. 24.

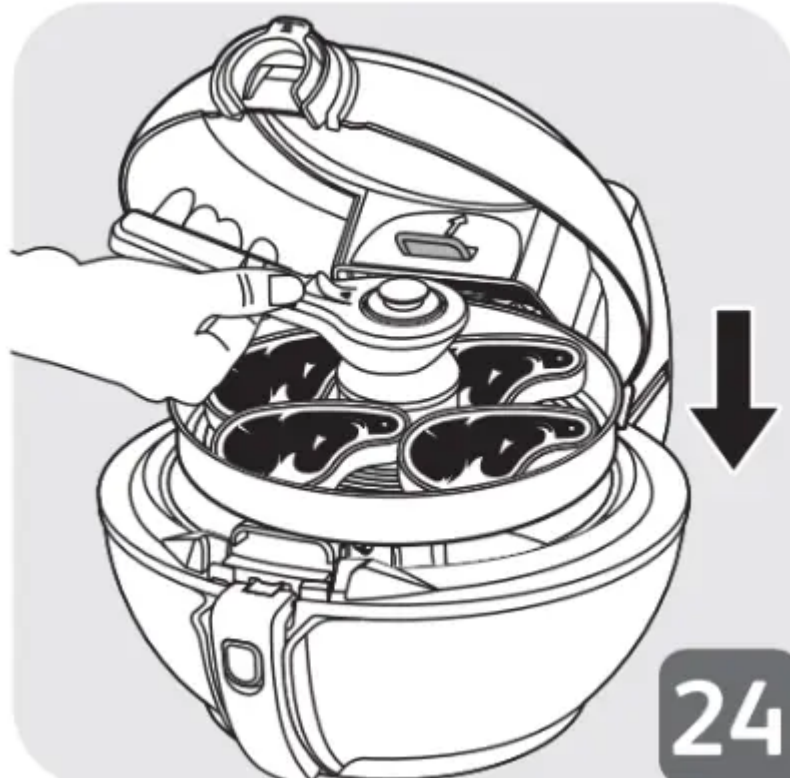



- Close the lid - fig. 25.



When using the tray on its own, do not put food into the cooking pan.

## Start the cooking

- Plug the appliance into an electrical socket outlet.
- The appliance will make a beep sound.
- Press the - button and the  flashes and the mode flashes '-'. Press the  key and the  icon appears on the screen.
- To select the cooking mode, press the + button until the required mode 2, 3, 4, 5, 6, 9, or M for manual mode is displayed.
- Press Start/Stop key.
- You can adjust the cooking time at any time by pressing +/- button
- The minute countdown starts. The countdown will only be displayed in seconds where there is less than a minute left.

**Opening the lid stops the cooking. You can resume cooking by closing the lid and pressing on the start button. Once the lid has been open for 3 minutes the appliance will go into stand-by mode.**

## Remove your food

- When the cooking is finished, the timer will sound and the screen will start flashing and displaying 0 min. The appliance automatically stops cooking your food.
- Open the lid - fig.29.



- Remove the tray using the tray handle and take your food out - fig 30. Be careful, the tray is very hot after cooking. Always use the tray handle supplied with your appliance to remove it.

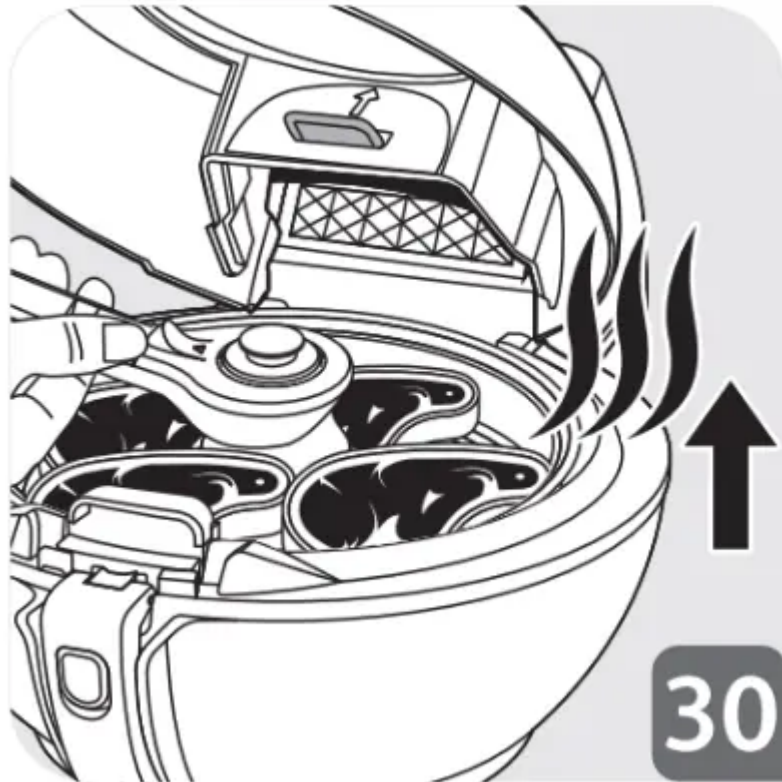

- Serve your food

### Cooking table for the tray ONLY

	Type	Quantity for tray	Actifry spoons of oil	Cooking mode	Cooking time for tray (mins)
Chicken nuggets	Fresh or Frozen	500 g	None	2	13 - 15
	Fresh or Frozen	750 g	None	2	15 - 17
Chicken drumsticks	Fresh	4 to 6 pieces	None	6	20 - 22
Chicken Wings	Frozen	10 pieces	None	6	22
Chicken breast (boneless)	Fresh	6 pieces	None	6	18 - 20
	Fresh	9 pieces	None	6	22 - 24
Meatballs	Frozen	500 g	1	5	12 - 15
	Frozen	750 g	1	5	15 - 17
Steak	Fresh	4 pieces	1*	5	8**
	Frozen	4 - 6 pieces	1 1/2*	5	8 - 10**

\* Brush steaks on both sides with oil.

\*\* Cooking time for rare steak. Add additional cooking time for medium and well done steaks

## USING THE 2IN1 PAN + TRAY

### Get your food ready

- Open the lid – fig.1



- Remove the tray and the removable turn-over ring from the cooking pan – fig.4.

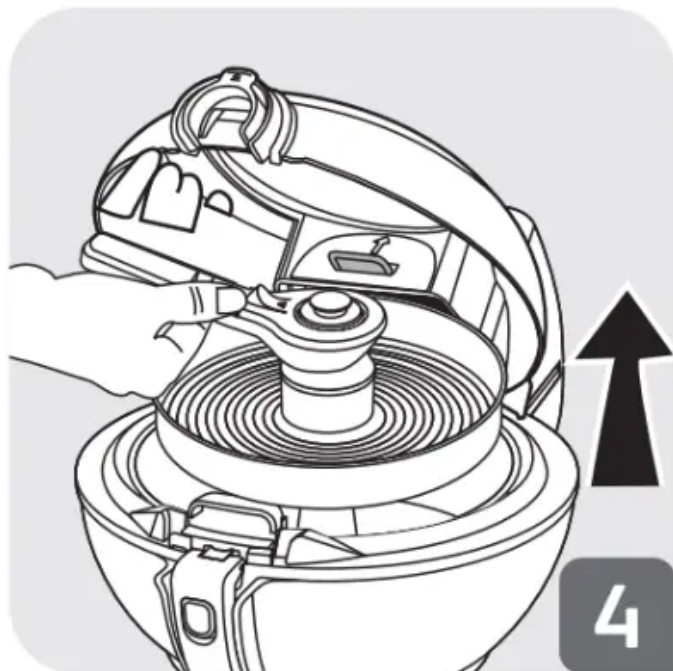

- Lift the handle up and remove the pan from the appliance.
- Place your food in the pan making sure you always keep to the quantities recommended in the cooking tables and/or the recipe book. Never exceed the MAX level indicated in the paddle.
- Depending on the food, add the recommended amount of oil in the ActiFry spoon and pour the contents evenly in to the pan – fig.13.



- Put the pan back in the appliance and close the lid - fig. 15.





### **Start the 2in1 cooking**

- Plug the appliance, it will make a beep sound and the screen displays the flashing icons  and '1' for mode, and 29 min.
- Choose the cooking program desired for the pan. To select the cooking mode, press the + button until the required mode 1 to 9 is displayed

- The icon  appears on the screen - fig.17.



- Press the key  to select the tray mode. The corresponding icon  appears on the screen.

- Choose the cooking program desired for the tray using the + button until the required mode 2, 3, 4, 5, 6, or M for manual mode is displayed - fig.18.



- Press START/STOP key - fig.19.

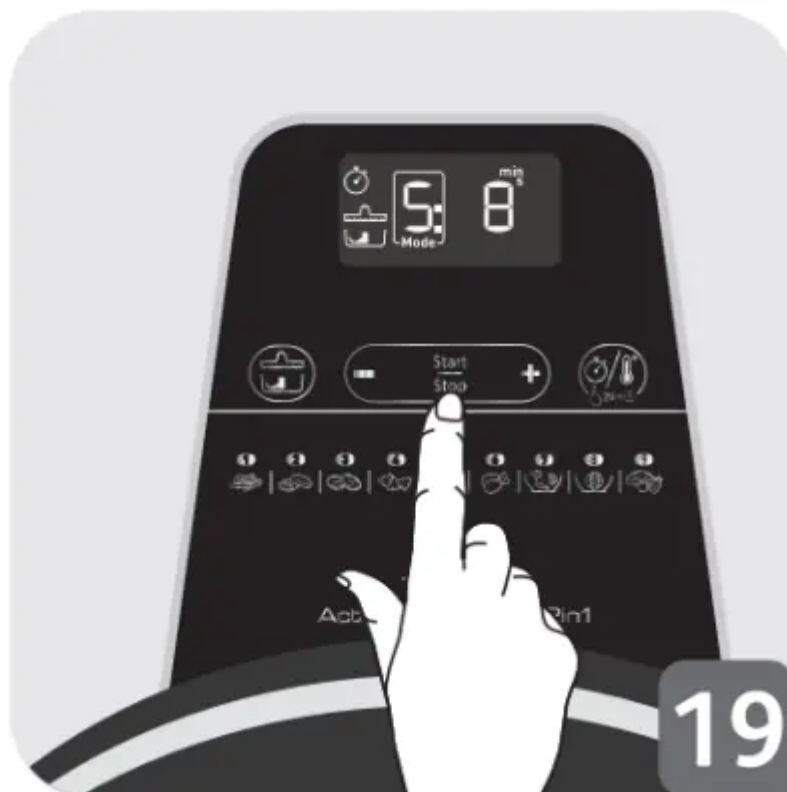

- You can adjust the cooking time at any time by pressing +/- button.
- The cooking of the food in the pan starts.
- The minute by minute countdown starts
- While the food is cooking in the pan, get the food ready for cooking on the tray. Make sure you do not exceed the maximum level mark on the tray - fig.23.



- When the appliance beeps and stops automatically, open the lid and put the tray in - fig. 22 & 24.

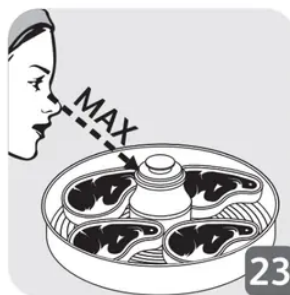

- Close the lid again - fig.25 and press the START button - fig.26.



- The minute countdown resumes. The countdown will only be displayed in seconds where there is less than a minute left.
- Adjust the cooking time at any time by pressing +/- buttons.
- There is a pre-set time for each cooking mode which you can adjust.
  - Adjust the cooking time in minutes using the + and - keys.
  - Adjust the cooking temperature by pressing the key  and the + and - buttons to set the temperature desired.

### Remove your food

- When the cooking is finished, the timer will sound and the screen will start flashing and displaying '0' min: the appliance automatically stops cooking your food.

- Open the lid - fig.29.



- Remove the tray with the tray handle and take your food out - fig.30. Be careful, the tray is very hot after cooking. Always use the tray handle supplied with your appliance to remove it.

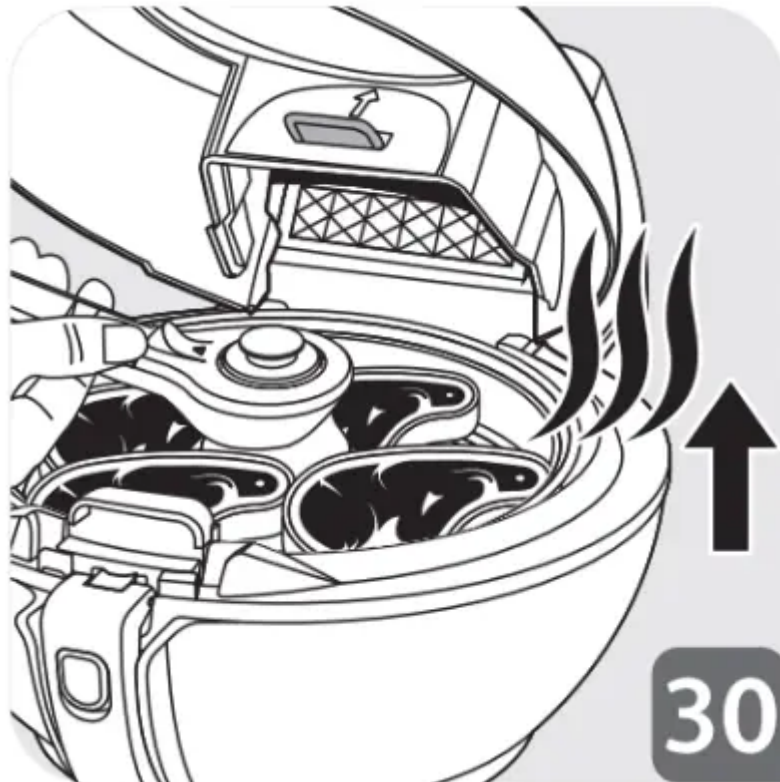

- Lift up the pan handle until you hear the “CLICK” - fig. 31.

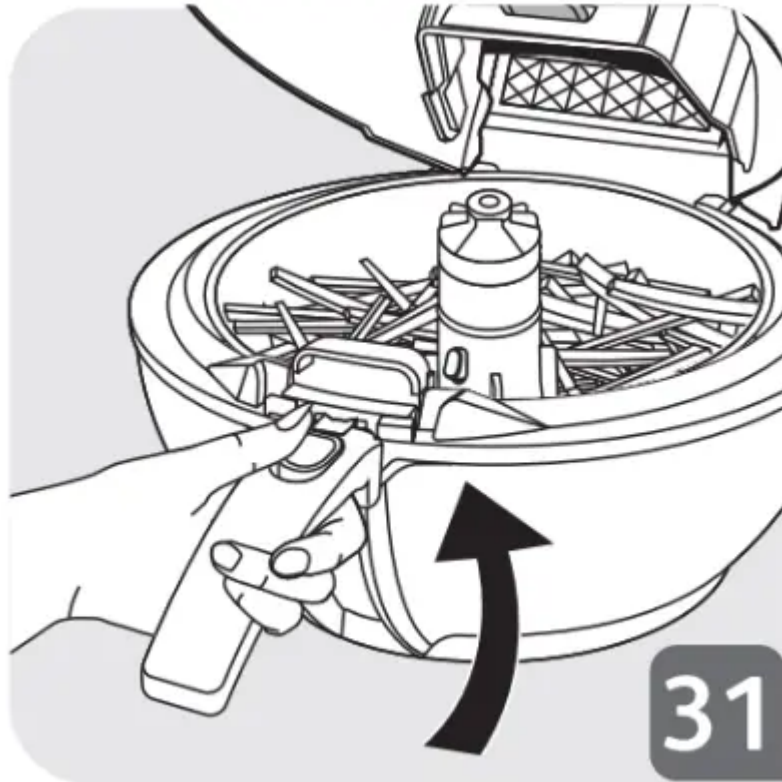

- Remove the pan and take your food out - fig. 32.

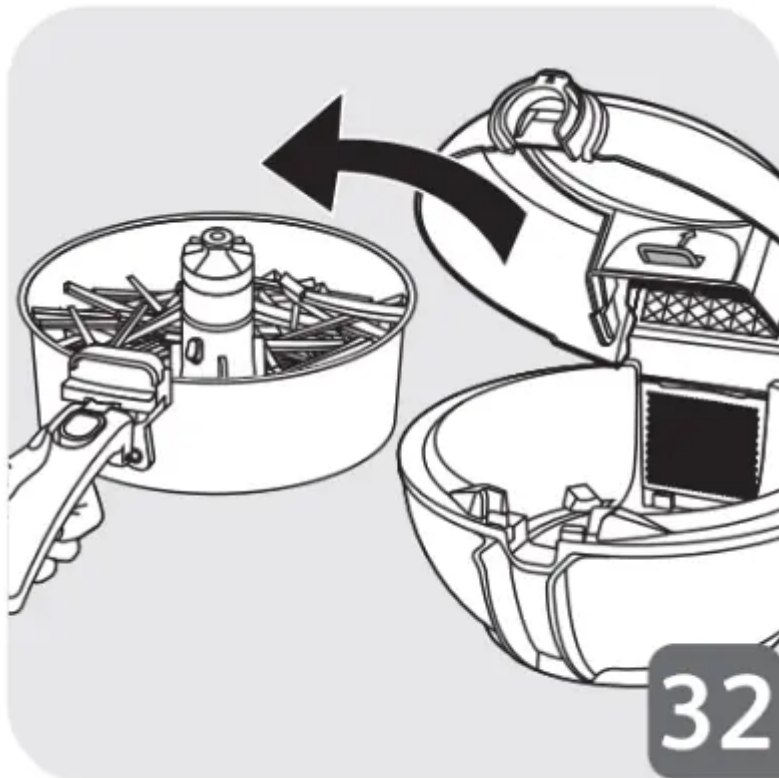

## Cooking table for 2in1

The cooking times given are a guide only, they may vary depending on the size of the food items and on how well done you like your food cooked. At the end of the 2in1 cooking time, if you like your chips or potatoes even more crispy cook them for a few extra minutes after you've removed the tray



Food in pan	Quantity in pan	Mode	Time for Pan	Food in tray	Tray quantity	Mode	Tray time
Fresh potato chips* 10 mm x 10mm	1500 g	1	35 min	Steaks	4	5	8 min**
	1200 g	1	32 min		4	5	7 min**
	750 g	1	27 min		3	5	6 min**
	250 g	1	15 min		1	5	5 min**
Fresh* or frozen chips	1200 g	1	32 min	Chicken drumsticks	8	6	15 min
	1000 g	1	30 min		4	6	15 min
	750 g	1	27 min		3	6	15 min
	250 g	1	20 min		1	6	10 min
Fresh* or frozen chips	1200 g	1	29 min	Home-made chicken nuggets	14	2	8 min
Fresh* or frozen chips	1200 g	1	32 min	Chicken wings	10	6	22 min
Courgettes, in slices	1200 g	7	25 min	Salmon fillet	4	5	10 min
	750 g	7	20 min		3	5	10 min
	500 g	7	15 min		2	5	8 min
	250 g	7	12 min		1	5	7 min
Figs cut in pieces	10	9	15 min	Filo chocolate parcels	4	9	4 min

\* For fresh chips add oil. For 1200 g add 1 ActiFry spoon, 1000 g add 3/4 spoon, 750 g add 1/2 spoon and 250 g add 1/4 spoon.

\*\* Cooking time for rare steak. Add additional cooking time for medium and well done steaks.

## DELAYED START

Delayed start can be set for pan on its own, tray on its own or 2in1 program with one of the 9 automatic cooking modes or manual mode.

- Plug in the appliance.
- First set the cooking mode and cooking time required.
- Then press the Temperature/Timer key  for 3 seconds. The pictogram  will appear, and the timer will flash '0' min.

- Set the delayed start time using the +/- buttons (Intervals: 10 minutes) (up to a maximum of 9 hours).
- Press START, and the delayed start timer will begin to count down. Cooking will begin once the delayed start timer reaches 0:00.

### KEEP WARM FUNCTION

- When cooking is finished, if no action is done after 3 minutes, the  keep warm mode automatically starts (except for mode 1 – Chips).
- After 30 minutes keeping warm, the appliance stops.
- To deactivate « Keep warm » function, press simultaneously + and – buttons for a long time (3 seconds).
- To re-activate « Keep warm » function, press simultaneously + and – buttons for a long time (3 seconds).

### ACTIFRY GENIUS COOKING TIPS

- Do not add salt to chips while the chips are in the cooking pan. Only add salt once the chips are removed from the cooking pan.
- When adding dried herbs and spices to ActiFry, mix them with some oil or liquid. If you try sprinkling them directly into the pan they will just get blown around by the hot air system.
- Strong coloured spices may slightly stain the paddle and parts of the appliance. This is normal.
- Prepare all food in evenly sized pieces to ensure that they all cook at the same time.
- Prepare vegetables, especially root vegetables, in small pieces or cut to stir fry size to ensure they cook through.
- If using onions in ActiFry recipes they are best thinly sliced rather than chopped as they cook better. Separate the onion rings before adding them to the cooking pan and give them a quick stir so that they are evenly distributed. For the automatic cooking mode only:
- For selected cooking modes, ingredients should be placed in the cooking pan as stated in the ActiFry Genius recipe book. This ensures the right level of cooking for each ingredient. Those which require a longer cooking time are put in the top half of the pan. Those requiring a shorter cooking time are put next to the handle.

## EASY TO CLEAN

### Cleaning the appliance

Never immerse the appliance in water or any other liquid. Do not use any corrosive or abrasive cleaning products. The removable filter must be cleaned regularly. To ensure your removable cooking pan and tray last longer, never use any metal utensils. We do not recommend the use of any detergent other than washing up liquid to clean any part of the appliance.

- Leave the appliance to cool completely before cleaning.
- Open the lid by pressing the button - fig.1 and push up the latch to remove the lid - fig.8.

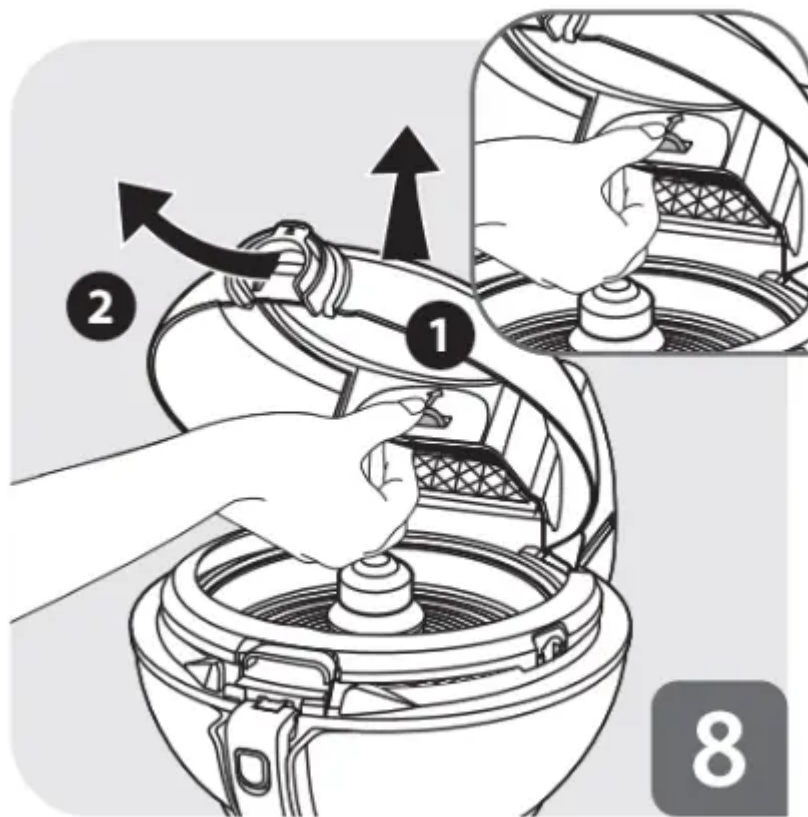

- Remove the tray.
- Lift the pan handle until you hear a «CLICK».

- Remove the paddle by pushing the release button - fig.6.

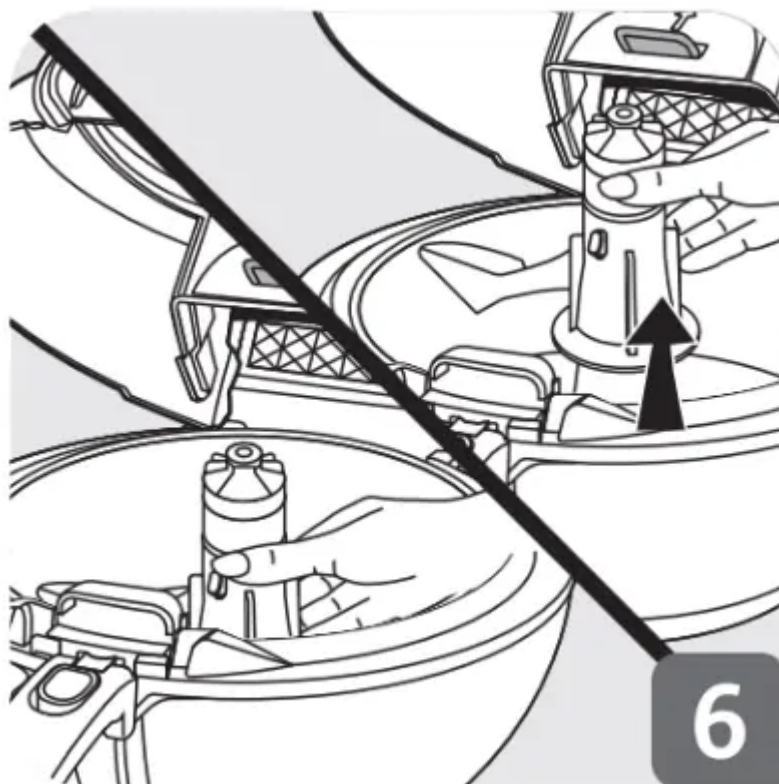

- Take out the cooking pan - fig.7.

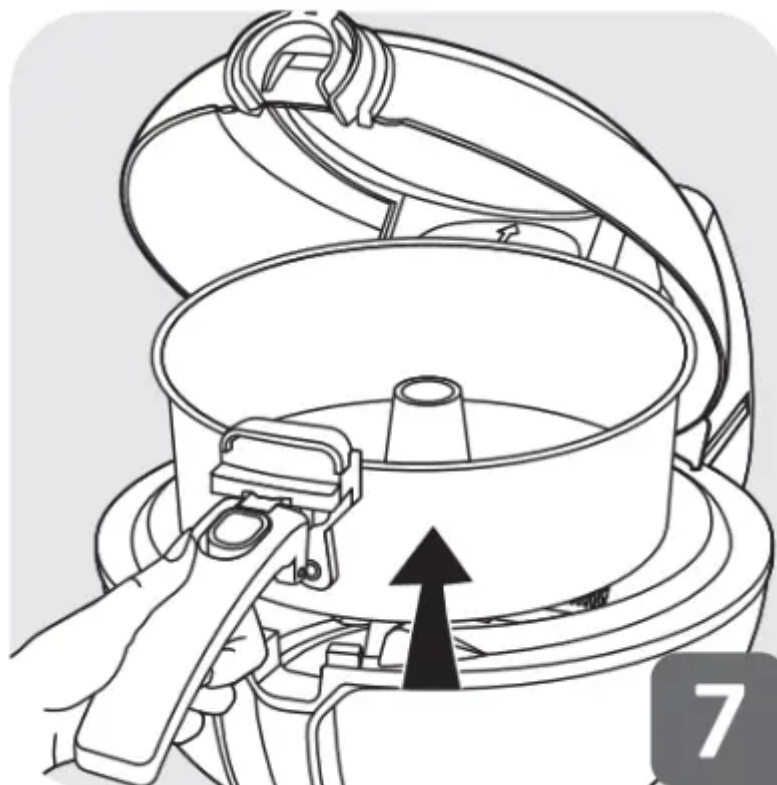

- Remove the detachable filter - fig.9.

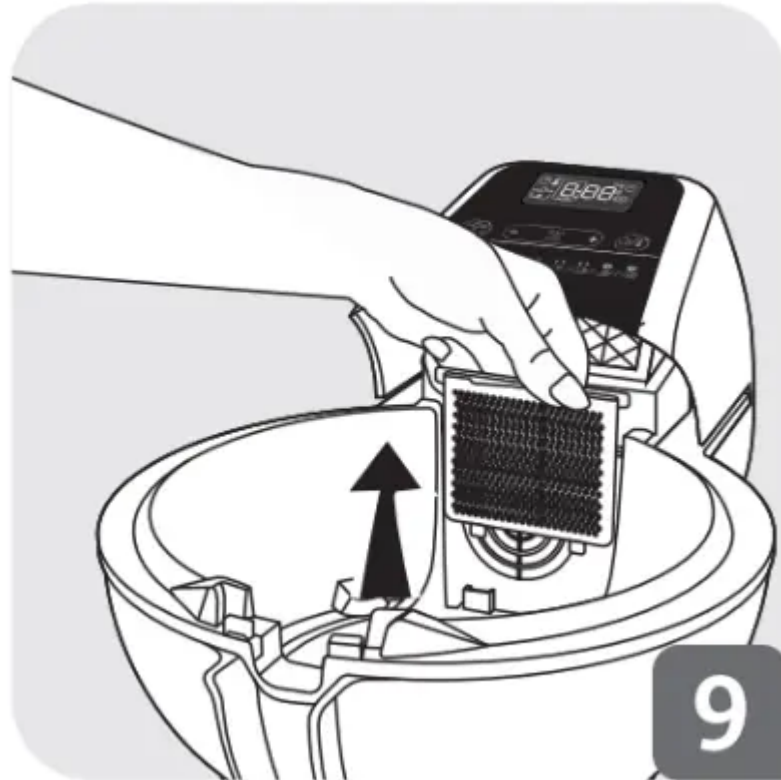

- To remove the turn-over ring, pull the clips outwards, then lift it off
- All the removable parts, except the tray handle (7), are dishwasher safe - fig.10 or can be cleaned using a non abrasive sponge and some washing up liquid.

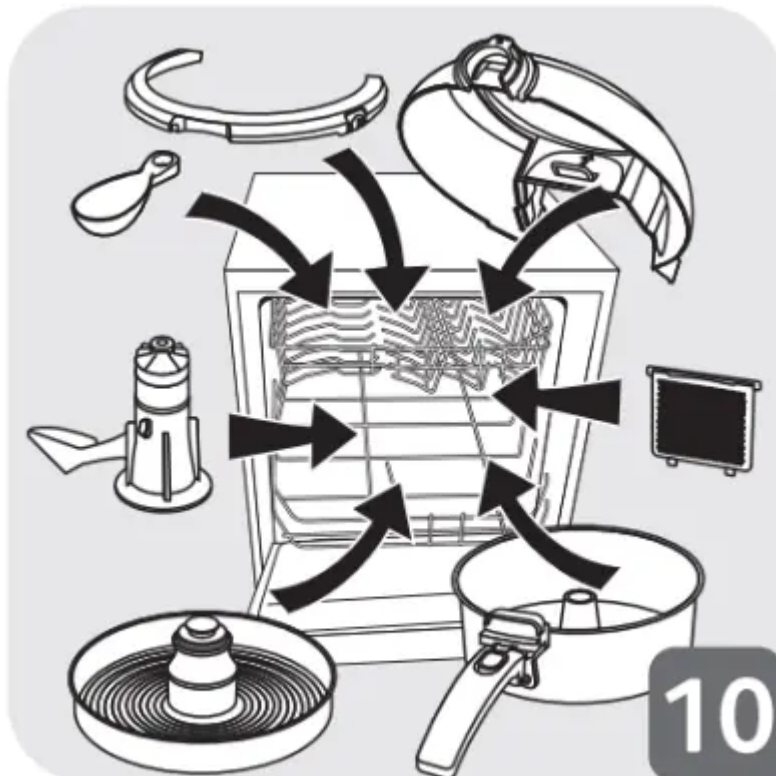

- Clean the inside and outside of the appliance and the handle with a damp sponge and a little washing up liquid - fig.11. Dry carefully before putting everything back in place.

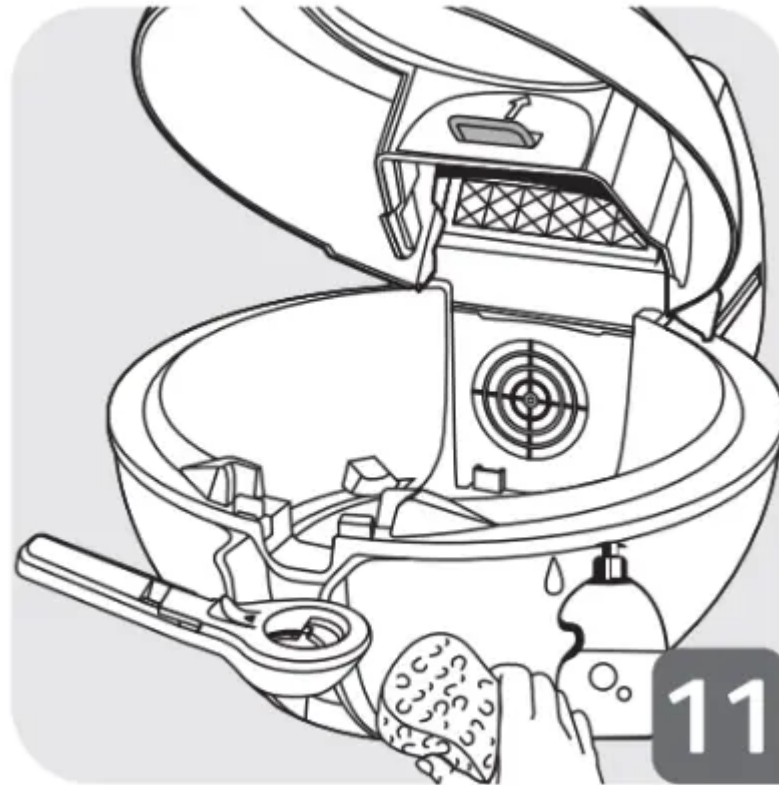

- If food gets stuck or burnt onto the pan or paddle, leave them to soak in warm water before cleaning.

## Troubleshooting

### Problems, Causes & Solutions

#### 1. The appliance does not work.

- The appliance is not plugged in properly.
  - Make sure the appliance is properly plugged in to a mains power socket.
- You have not yet pressed START/ STOP button .
  - Press START/STOP button .
- You have pressed START/STOP button but the appliance does not operate.
  - Close the lid.
- The appliance is not heating.
  - Call the customer Helpline (see below)

- The paddle does not turn.
  - The paddle does not turn at the beginning of cooking in cooking modes 2, 3, 4, 5, 7, 8 and 9. Restart using the manual mode to check the paddle turns. If it does not turn, check that it is correctly in place and adjust until you hear a “CLICK” sound. If it still does not operate contact our the customer Helpline.

2. The paddle does not stay in place

- The paddle is not locked.
  - Reposition the paddle until you hear it «CLICK» - fig.12.



3. The tray does not turn.

- The tray is not locked.
  - Adjust the position until you hear the “CLICK” sound.

4. The food has not been cooked uniformly

- You have not used the paddle.
  - Put it in position.
- The food / chips have not been cut uniformly.
  - Cut the food / chips all to the same size

5. The chips are not crispy enough.

- You are using a variety of potatoes unsuitable for chips.
  - Choose a variety of potato suitable for chips such as Maris Piper or King Edward for best results. Freshly harvested potatoes may have a

high moisture content, either cook for a few minutes more or try using a different batch and/or variety of potatoes.

- The potatoes haven't been sufficiently washed and dried.
    - Wash, drain and dry the potatoes thoroughly before cooking.
  - The chips are too thick.
    - Cut them more thinly.
  - There's not enough oil.
    - Increase the quantity of oil (see "Cooking table").
  - The filter (5) is blocked.
    - Clean the filter.
6. The food won't turn with the tray.
- The food is too thick.
    - Reduce the thickness of your food.
7. The food in the pan isn't cooked when using for 2in1 cooking.
- The tray was put on the pan when the cooking started.
    - Only put the tray in during the second half of the cooking phase.
8. The chips become broken whilst they are being cooked.
- You are using too large a quantity or the chips are too long.
    - Reduce the quantity of potatoes and adjust cooking time. Or do not cut chips longer than 9 cm in length.
9. The food remains on the edge of the pan.
- The pan has too much food.
    - Comply with the maximum quantities shown on the cooking table. Put the turn-over ring in place when cooking chips. Reduce the amount of food.
  - Maximum level recommended exceeded.
    - Reduce the quantities.
10. The LCD screen does not work.
- The appliance is not plugged in.
    - Plug the appliance in.

- The lid is open.
  - Close the lid.

11. The appliance is abnormally noisy.

- You suspect there is a problem in the way the appliance motor is working.
  - Call the customer Helpline below.

**Warning**

This content is compiled from multiple sources and is provided for reference purposes only. It may not be complete or fully applicable to all situations. If you are unable to resolve your issue, please contact the product manufacturer or an authorized service provider for official support.