

IMPORTANT SAFETY INSTRUCTIONS

FOR HOUSEHOLD USE ONLY · WHEN USING AN ELECTRICAL APPLIANCE, BASIC PRECAUTIONS SHOULD ALWAYS BE FOLLOWED, INCLUDING THE FOLLOWING. PLEASE READ ALL INSTRUCTIONS BEFORE USING THIS VACUUM.

If the charging cord plug does not fit fully into the outlet, reverse the plug. If it still does not fit, contact a qualified electrician. DO NOT force into outlet or try to modify to fit.

To reduce the risk of shock and unintended operation, turn off power and remove the battery before servicing.

A WARNING

To reduce the risk of fire, electric shock, injury, or property damage:

THE FLOOR NOZZLE, WAND, AND HANDHELD VACUUM CONTAIN ELECTRICAL CONNECTIONS:

1. This vacuum consists of a motorized nozzle, wand, and handheld vacuum. These components contain electrical connections, electrical wiring, and moving parts that potentially present risk to the user.
2. Before each use, carefully inspect all parts for any damage. If a part is damaged, discontinue use.
3. Use only identical replacement parts.
4. This vacuum contains no serviceable parts.
5. Use only as described in this manual. DO NOT use the vacuum for any purpose other than those described in this manual.
6. With the exception of the filters and dust cup, DO NOT expose any parts of the vacuum to water or other liquids.
7. Keep the appliance and its cord out of reach of children. Do not allow the appliance to be used by children. Do not allow to be used as a toy. Close supervision is necessary when used near children.

GENERAL USE

1. This appliance can be used by persons with reduced physical, sensory, or mental capabilities or lack of experience and knowledge if they have been given supervision or instruction concerning use of the appliance in a safe way and understand the hazards involved. Cleaning and user maintenance shall not be made by children.
2. Always turn off the vacuum before connecting or disconnecting any current carrying hoses, motorized nozzles, chargers, batteries, or other electrical or mechanical parts.
3. DO NOT handle plug or vacuum with wet hands.
4. DO NOT use without dust cup, filters, and brushroll in place.
5. Only use Shark® branded filters and accessories.
6. DO NOT put any objects into nozzle or accessory openings. DO NOT use with any opening blocked; keep free of dust, lint, hair, and anything that may reduce airflow.
7. DO NOT use if nozzle or accessory airflow is restricted. If the air paths or the motorized floor nozzle become blocked, turn the vacuum off. Remove all obstructions before you turn on the unit again.
8. Keep nozzle and all vacuum openings away from hair, face, fingers, uncovered feet, or loose clothing.
9. DO NOT use if vacuum is not working as it should, or has been dropped, damaged, left outdoors, or dropped into water.
10. Use extra care when cleaning on stairs.
11. DO NOT leave the vacuum unattended while powered on.
12. When powered on, keep the vacuum moving over the carpet surface at all times to avoid damaging the carpet fibers.
13. DO NOT place vacuum on unstable surfaces such as chairs or tables.
14. DO NOT use to pick up:
 - a) Liquids
 - b) Large objects
 - c) Hard or sharp objects (glass, nails, screws, or coins)
 - d) Large quantities of dust (including drywall, fireplace ash, or embers). DO NOT use as an attachment to power tools for dust collection.
 - e) Smoking or burning objects (hot coals, cigarette butts, or matches)
 - f) Flammable or combustible materials (lighter fluid, gasoline, or kerosene)
 - g) Toxic materials (chlorine bleach, ammonia, or drain cleaner)
 1. DO NOT use in the following areas:
 - a) Poorly lit areas
 - b) Wet or damp surfaces

c) Outdoor areas

d) Spaces that are enclosed and may contain explosive or toxic fumes or vapors (lighter fluid, gasoline, kerosene, paint, paint thinners, mothproofing substances, or flammable dust)

1. Turn off the vacuum before plugging in or unplugging the charger.
2. Turn off the vacuum before any adjustment, cleaning, maintenance or troubleshooting.
3. During cleaning or routine maintenance, DO NOT cut anything other than hair, fibers, or string wrapped around the brushroll.
4. Allow all filters to air-dry completely before replacing in the vacuum to prevent liquid from being drawn into electric parts.
5. DO NOT modify or attempt to repair the vacuum or the battery yourself, except as indicated in this manual. DO NOT use the battery or vacuum if it has been modified or damaged. Damaged or modified batteries may exhibit unpredictable behavior resulting in fire, explosion, or risk of injury.
6. Turn off all controls before unplugging.
7. Always turn off this appliance before connecting or disconnecting motorized nozzle or hand tool.

BATTERY PACK

1. The battery is the power source for the vacuum. Carefully read and follow all charging instructions.
2. To prevent unintentional starting, ensure the vacuum is powered off before picking up or carrying the vacuum. DO NOT carry the appliance with your finger on the power switch.
3. Use only Shark charger DK33-248080H-U. Use of an incorrect charger may result in no charging, and/or unsafe conditions. A charger that is suitable for one type of battery pack may create a risk of fire when used with another battery pack.
4. Keep the battery away from all metal objects such as paper clips, coins, keys, nails, or screws. Shorting the battery terminals increases the risk of fire or burns.
5. Under abusive conditions, liquid may be ejected from the battery. Avoid contact with this liquid, as it may cause irritation or burns. If contact occurs, flush with water. If liquid contacts eyes, seek medical help.
6. Battery should not be stored at temperatures below 37.4°F (3°C) or above 104°F (40°C) to maintain longterm battery life.
7. DO NOT charge battery at temperatures below 40°F (5°C) or above 104°F (40°C). Charging improperly or at temperatures outside of the specified range may damage the battery and increase the risk of fire.

8. Store the appliance indoors. DO NOT use or store it below 37.4°F (3°C). Ensure the appliance is at room temperature before operating.
9. DO NOT expose the battery to fire or temperatures above 265°F (130°C) as it may cause explosion.
10. For IZ360 and UZ360 Series. Disconnect the battery pack from the appliance before making any adjustments, changing accessories, or storing appliance. Such preventive safety measures reduce the risk of starting the appliance accidentally.
11. Use appliances only with specifically designated battery packs. Use of any other battery packs may create a risk of injury and fire.
12. For IZ362H, use only with Shark battery pack XSBT620. For IZ363HT, use only with Shark battery pack XSBT600.

ASSEMBLY

Your vacuum comes equipped with a standard wand with a storage clip and the PowerFins® floor nozzle. In some models, the battery in the handheld vacuum is removable, while in others the battery is non-removable. All versions assemble the same way.

1. Insert Wand into Floor Nozzle.
2. Insert Handheld Vacuum into wand.

For proper operation, ensure all components are completely connected and clicked into place.

**Handheld Vacuum with
non-removable battery
IZ340H**

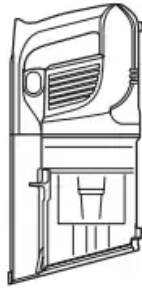

OR

**Handheld Vacuum
with removable battery
IZ362H, IZ363HT,
UZ365H**

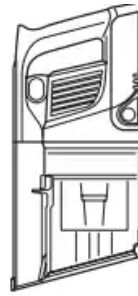

2. ↓

**Standard Wand with
Handheld Vacuum
Storage Clip**



1. ↓

**PowerFins
Floor Nozzle**

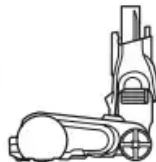

NOTE: Your vacuum's model and serial numbers can be found on the QR code label on the bottom of the back of the handheld vacuum

LI-ION BATTERY

Prior to first use, charge completely. A full charge takes approximately 3 hours.

RUNTIMES PER FULLY CHARGED BATTERY

Visit sharkclean.com/support online or review the included Quick Start Guide.

LED BATTERY POWER AND CHARGING INDICATORS

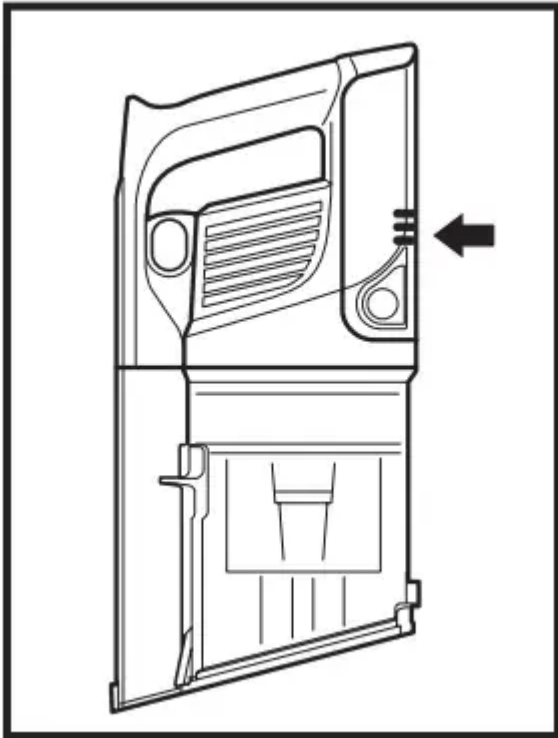

Charging

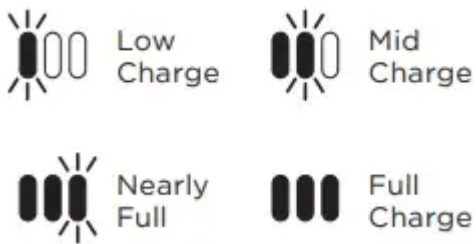

NOTE: Full charge takes approximately 3 hours.

In Use

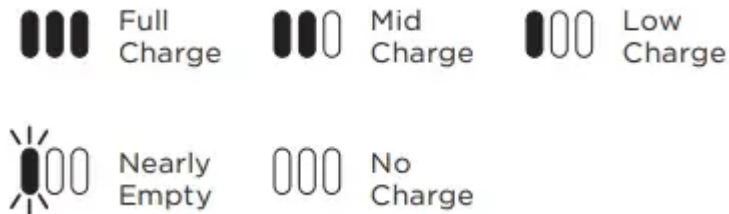

RECYCLING THE LI-ION BATTERY

When the Shark Li-ion battery needs to be replaced, dispose of it or recycle it in accordance with local ordinances or regulations. In some areas, it is illegal to place spent lithium-ion batteries in the trash or in a municipal solid waste stream. Return spent batteries to an authorized recycling center

or to the retailer for recycling. Contact your local recycling center for information on where to drop off the spent battery.

NOTE: The Shark battery, like all lithium-ion batteries, will naturally decrease in capacity over time from the 100% capacity of a new battery.

CHARGING INSTRUCTIONS

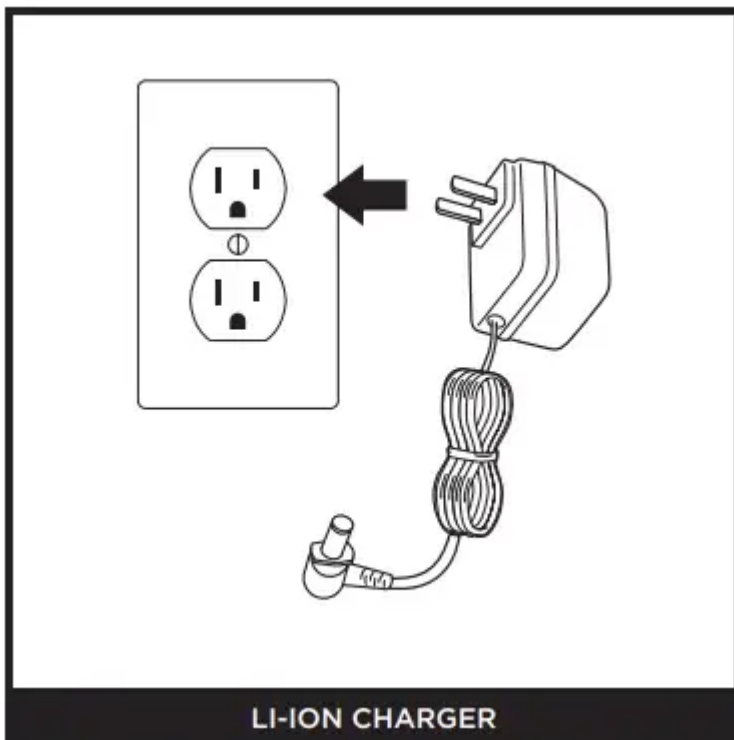

Plug the **Li-Ion Charger** into a wall outlet.

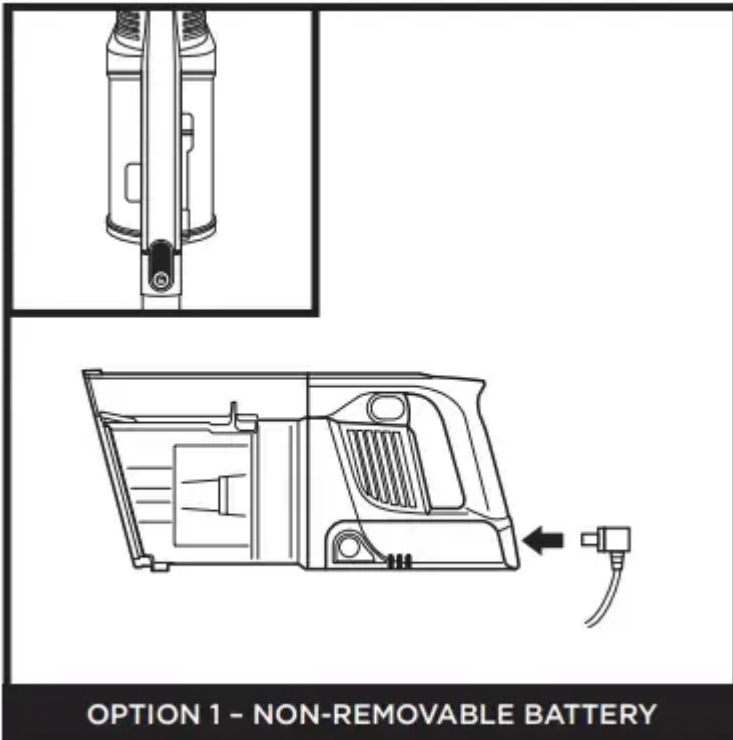

If your handheld vacuum's battery is nonremovable, press the **Wand Release button** to detach the handheld vacuum, then plug the charger into the charging port on the handheld vacuum.

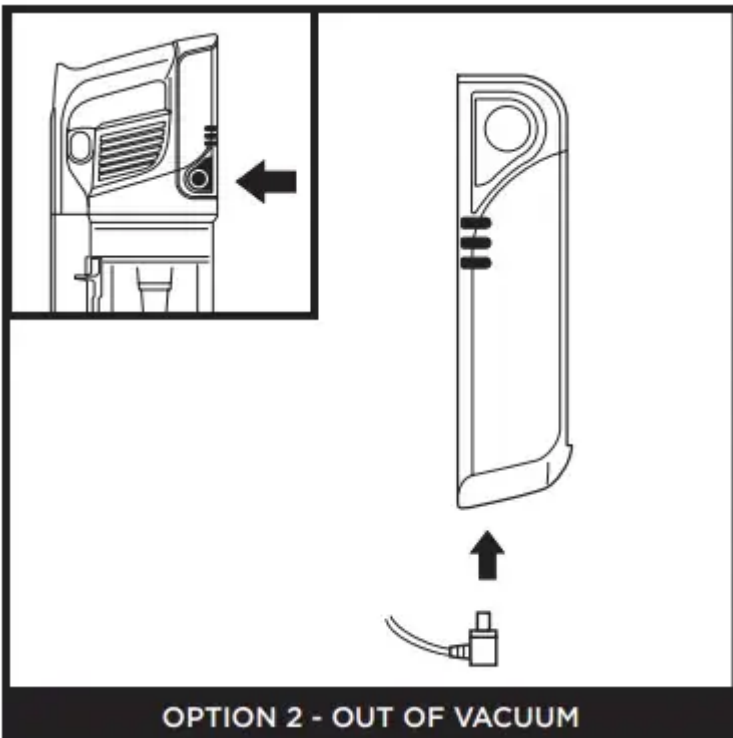

If the battery is removable, press and hold the **battery release button**, then slide out the battery. Plug the charger into the charging port on the battery. To re-install the battery, slide it into the slot in the back of the handheld vacuum.

POWER SETTINGS

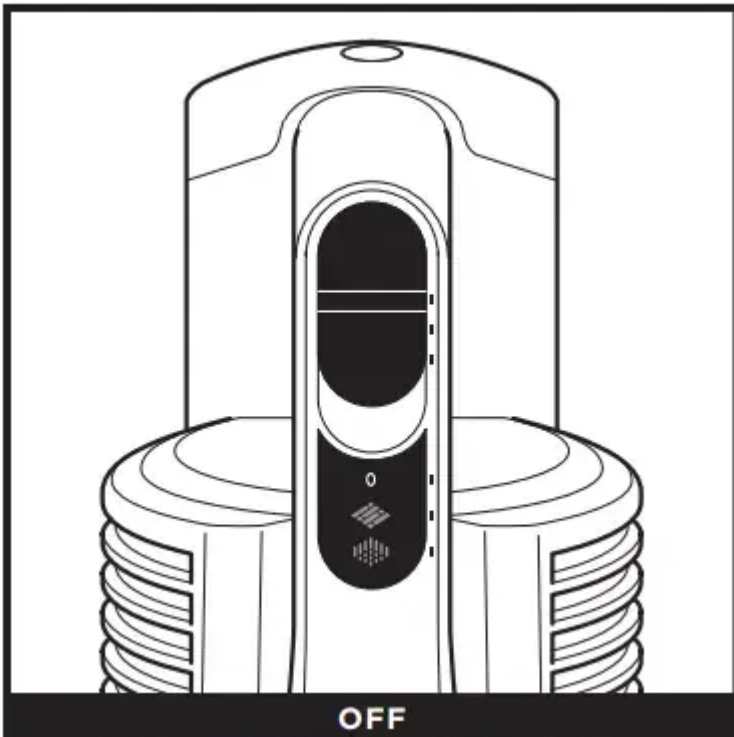

Slide switch to the top to turn off power. To begin vacuuming in **Standard Mode**, slide switch to the desired setting.



Bare Floor/Small Area Rugs: Use this setting to clean bare floors and small area rugs.

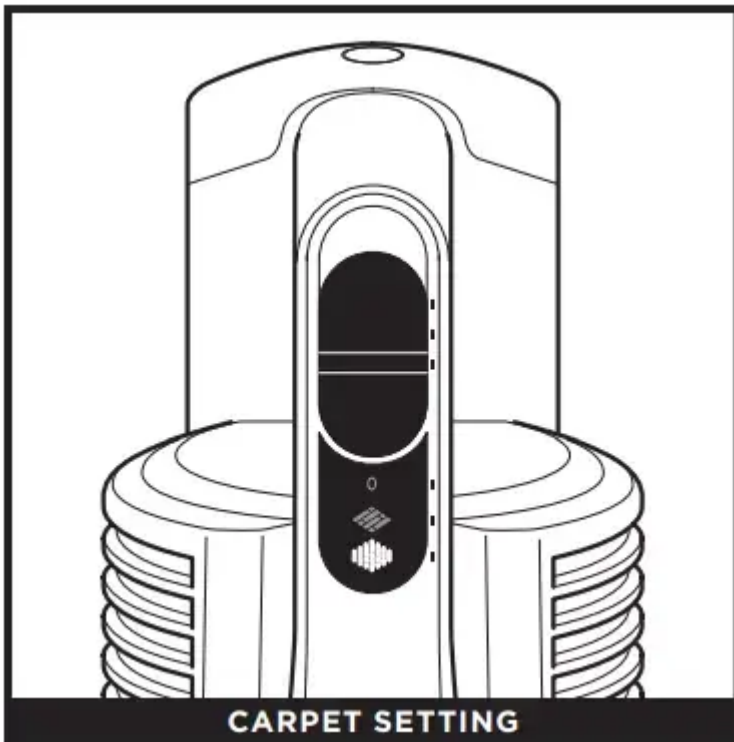

Carpet: Use this setting to pick up debris below the surface of your carpets.

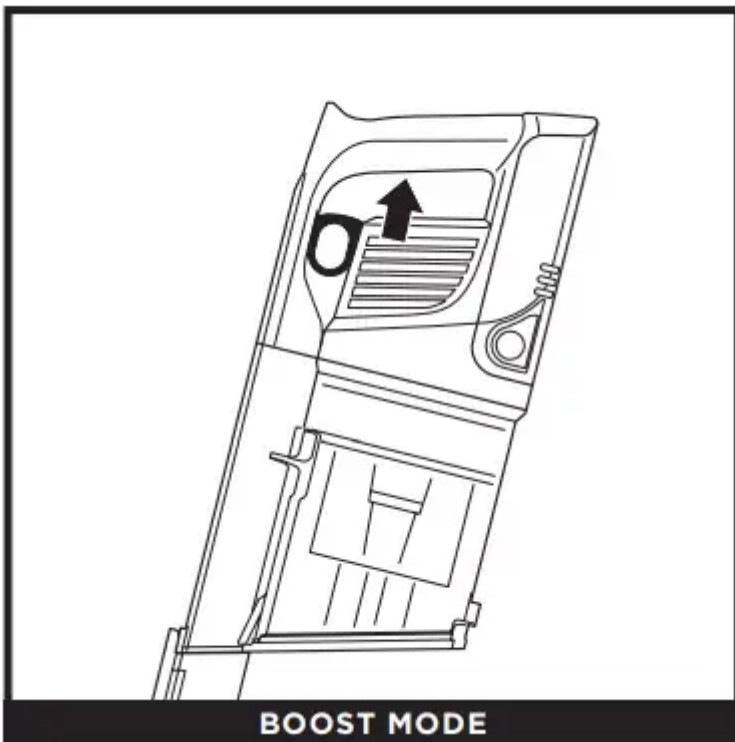

For an added boost in power, pull the **Trigger** on the handheld vacuum. Release it to return to standard power.

CLEANING MODES



To clean floors, step on floor nozzle and tilt handheld vacuum back. NOTE: Brushroll will only engage when the handheld vacuum and wand are tilted back.

NOTE: Brushroll will only engage when the handheld vacuum and wand are tilted back.

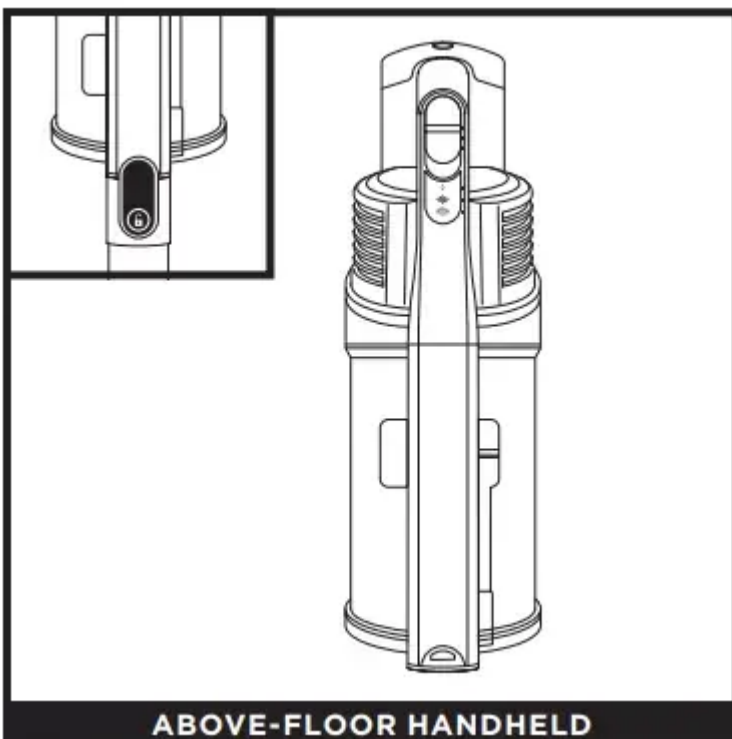

Press the wand release button and lift the handheld vacuum off the wand. Attach an accessory for great cleaning on stairs, furniture, and other above-floor areas.

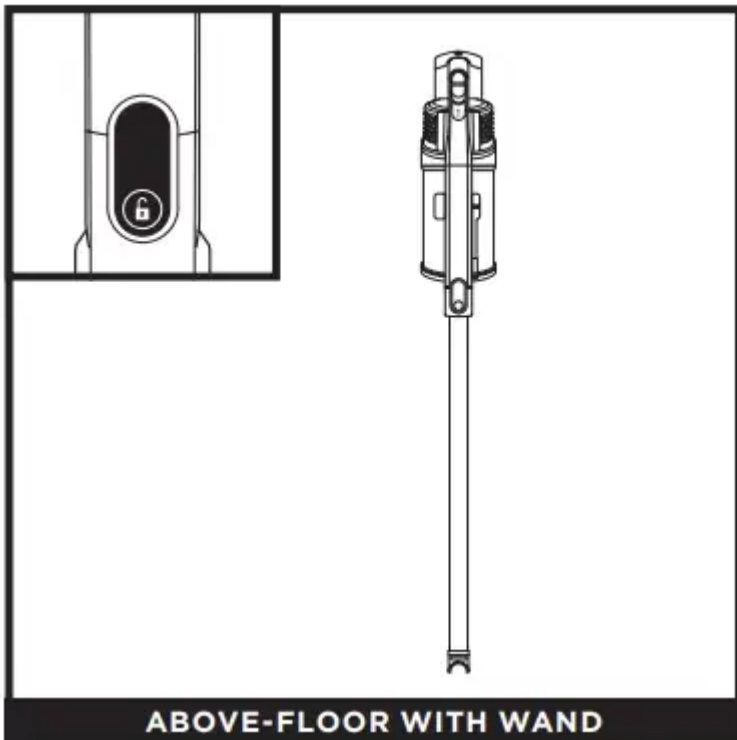

Stand the vacuum upright and press the nozzle release button located at the bottom of the wand, above the nozzle. Lift wand to detach.

Great for cleaning baseboards, ceiling fans, window sills, and other hard-to-access areas.

NOTE: All accessories are compatible with both the wand and the handheld vacuum.

STORAGE

ONBOARD STORAGE

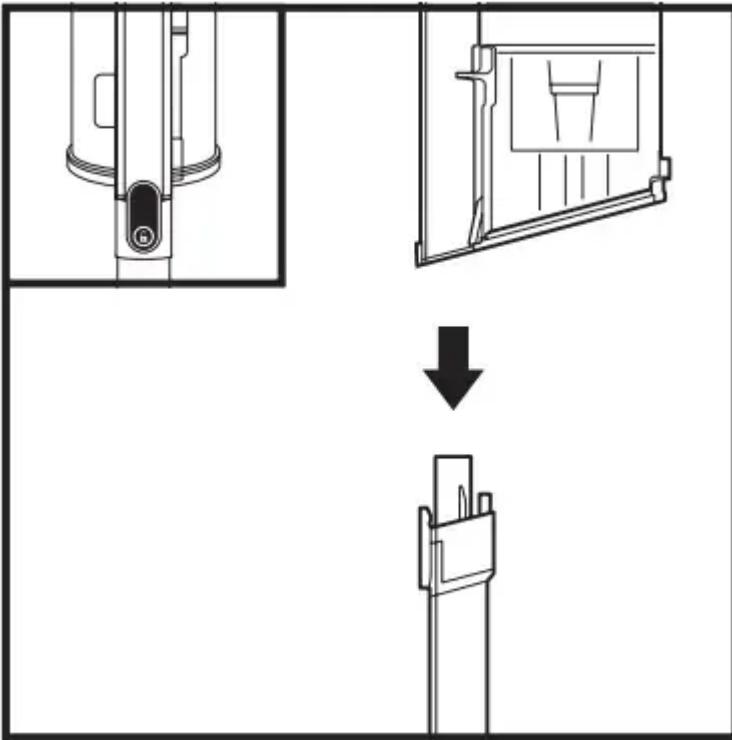

Press the Wand Release button at the top of the wand to detach the handheld vacuum.

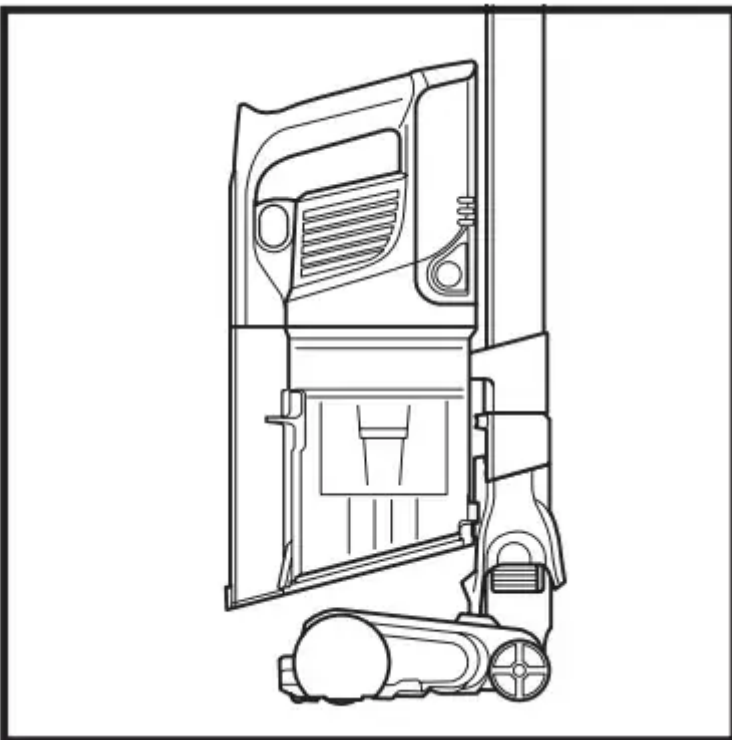

Hang the handheld vacuum from the storage hook on the wand.

MAINTAINING YOUR VACUUM

EMPTYING THE DUST CUP

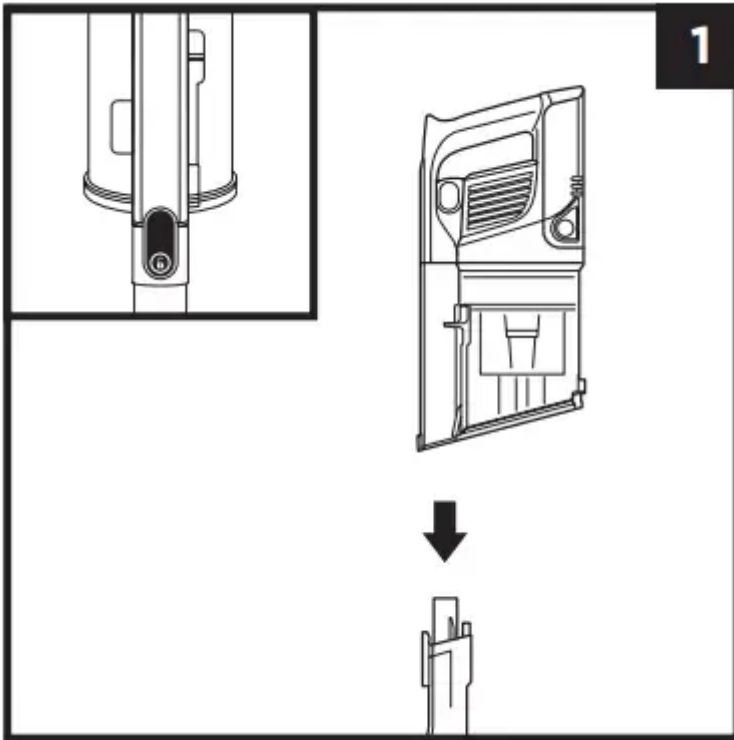

Press the wand release button to disconnect the handheld vacuum from the wand.

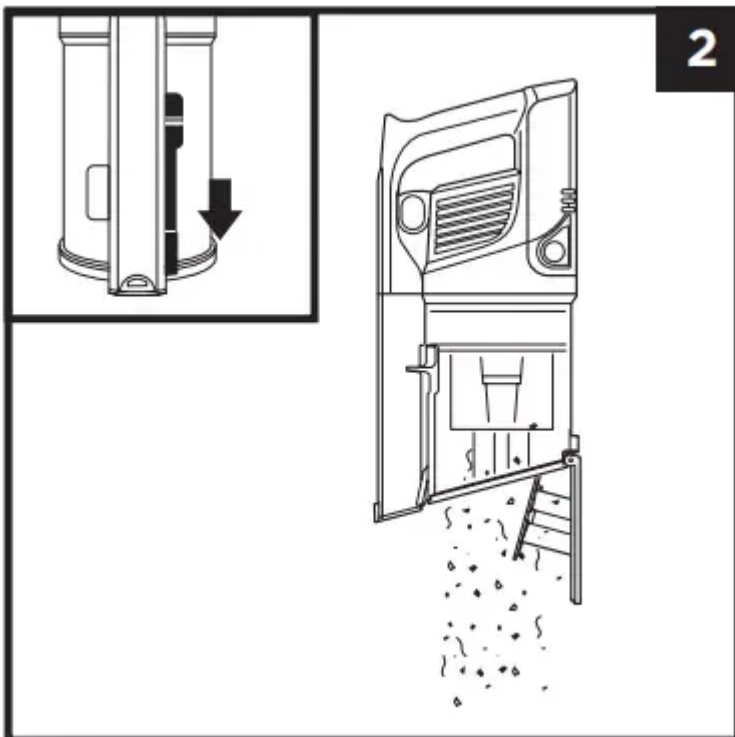

To empty the **Dust Cup** while it is attached to the handheld vacuum, position the dust cup over a trash receptacle and slide the **CleanTouch® Lid Release** slider forward.

REMOVING AND CLEANING THE DUST CUP

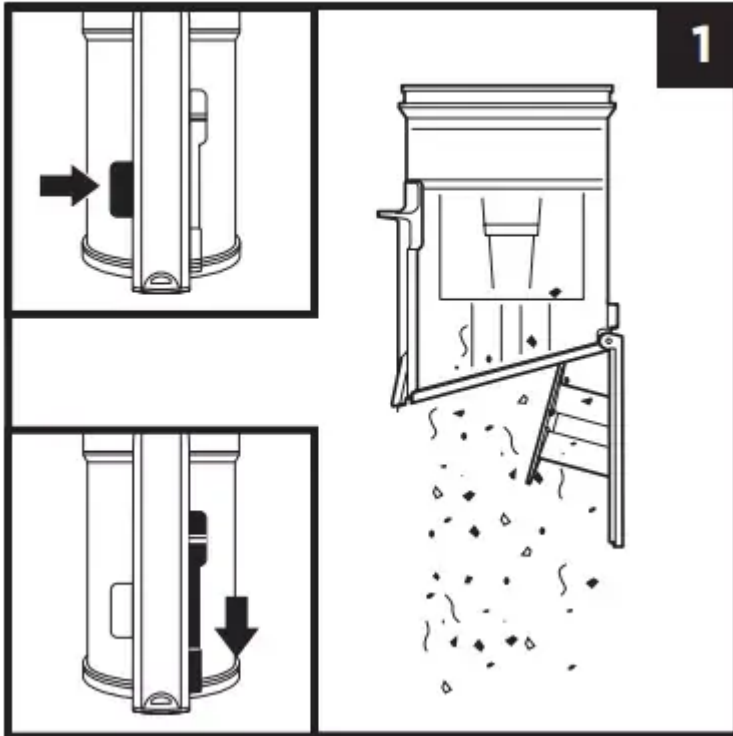

To empty dust cup from the handheld vacuum, press the **Dust Cup Release** button near the handheld vacuum nozzle. Tilt the dust cup and lift off to remove.

To empty dust and debris, hold the dust cup over the trash, then slide the **Lid Release** slider forward.

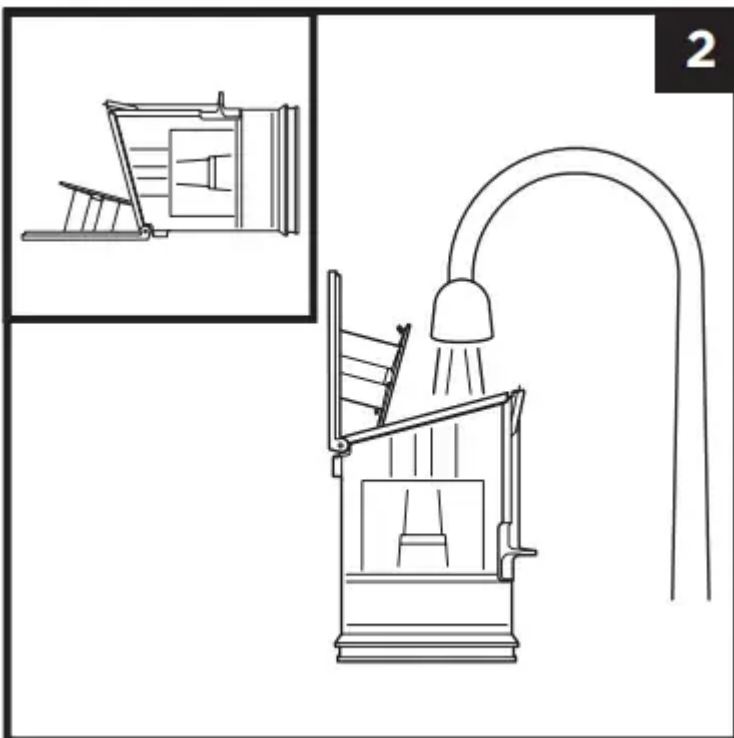

To clean the interior of the dust cup, rinse it with water. Place it on its side to air-dry for at least 24 hours before reinstalling.

CLEANING THE FILTERS

Regularly rinse and replace the filters to maintain your vacuum's suction power.

To clean filters, rinse them with water only. Allow all filters to air-dry completely for at least 24 hours before reinstalling to prevent liquid from being drawn into electric parts. Clean the pre-motor filters at least once a month and post-motor filter at least once a year. Tap off loose dirt between washes when needed. More frequent cleaning may sometimes be necessary with heavy use.

IMPORTANT: DO NOT use soap when cleaning the filters. Use water only.

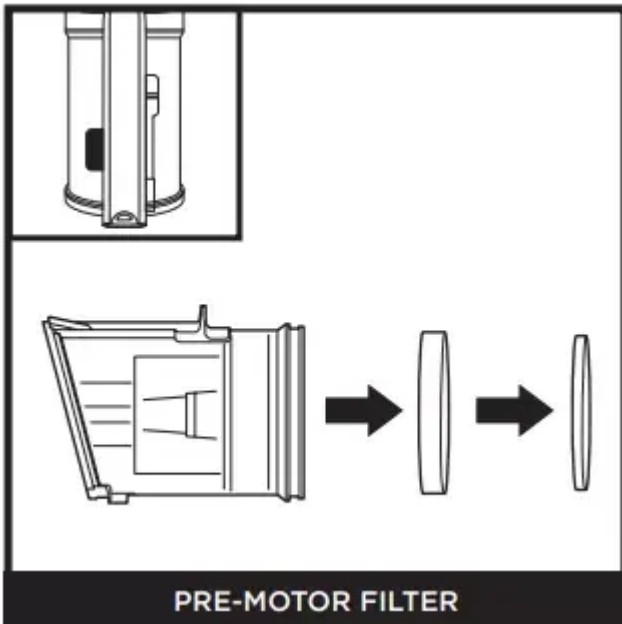

Press the dust cup release button and remove the dust cup. Pull the foam and felt filters out of the back of the dust cup.

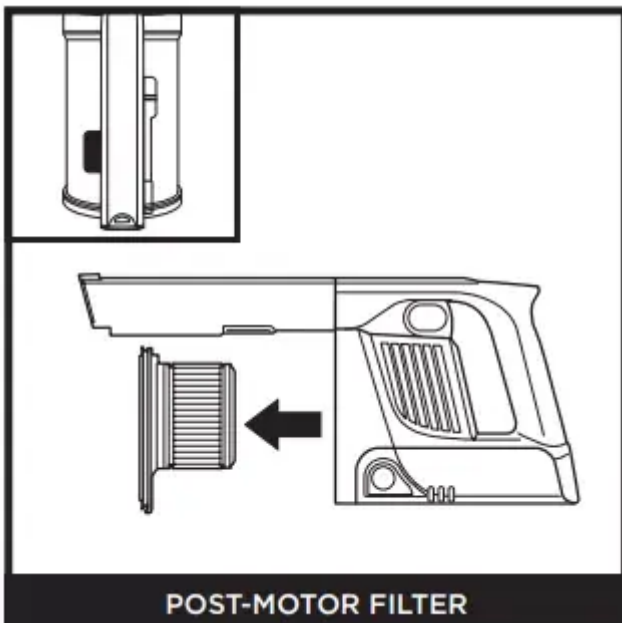

Remove the dust cup. Pull the post-motor filter out of the handheld vacuum.

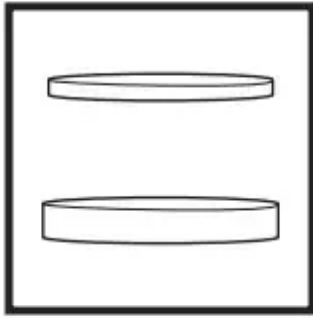

Pre-Motor Foam and Felt Filter Kit

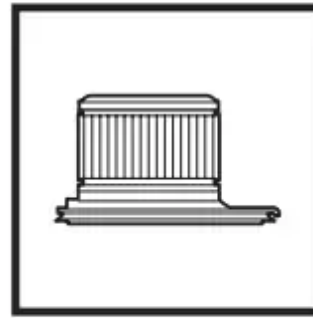

Post-Motor HEPA Filter

FLOOR NOZZLE

If you run over a hard or sharp object or notice a noise change while vacuuming, check for blockages or objects caught in the brushroll.

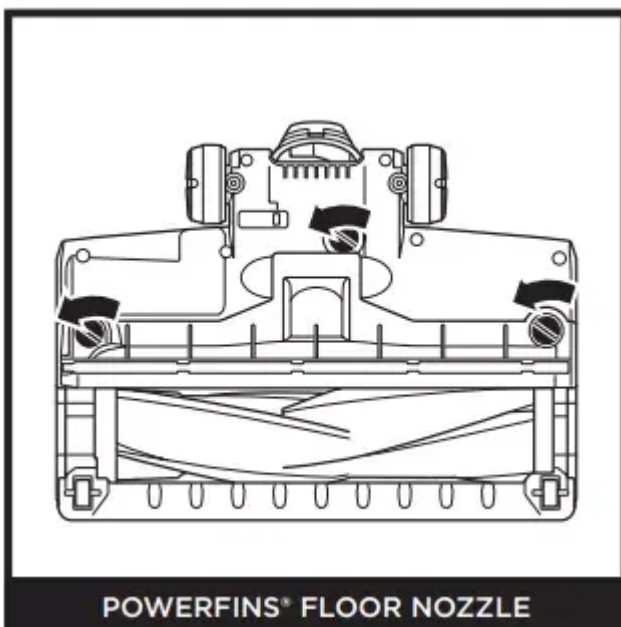

1. Turn off the vacuum.
2. Using a coin, turn locks counterclockwise to open, then lift off cover to access brushroll.
3. Clear airway of blockages.
4. Replace cover by sliding inserts into slots, then pressing down firmly on all sides before turning locks clockwise to close. When the locks are securely closed, they will click into place.

CLEANING THE POWERFINS BRUSHROLL

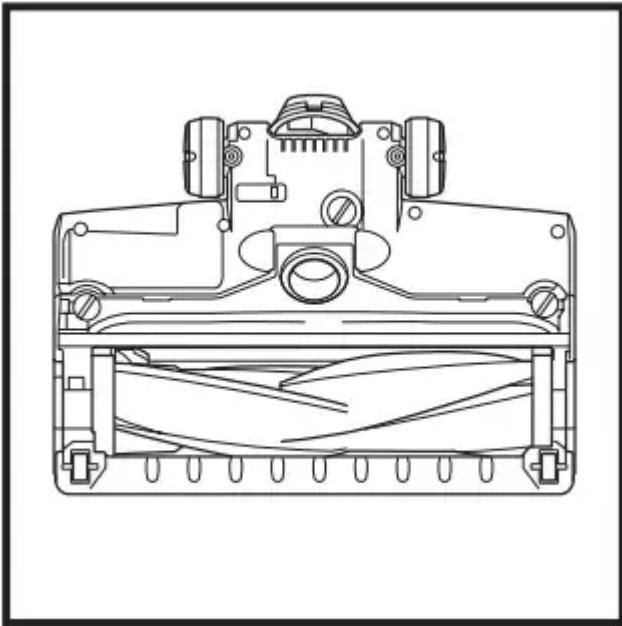

If any hair is wrapped around the brushroll, continue cleaning, using the Carpet setting on a bare floor surface, a low-pile carpet, or a small area rug. If some fibers remain after continued use, carefully remove them from the brushroll.

CHECKING FOR BLOCKAGES

Checking for Blockages in the Handheld Vacuum:

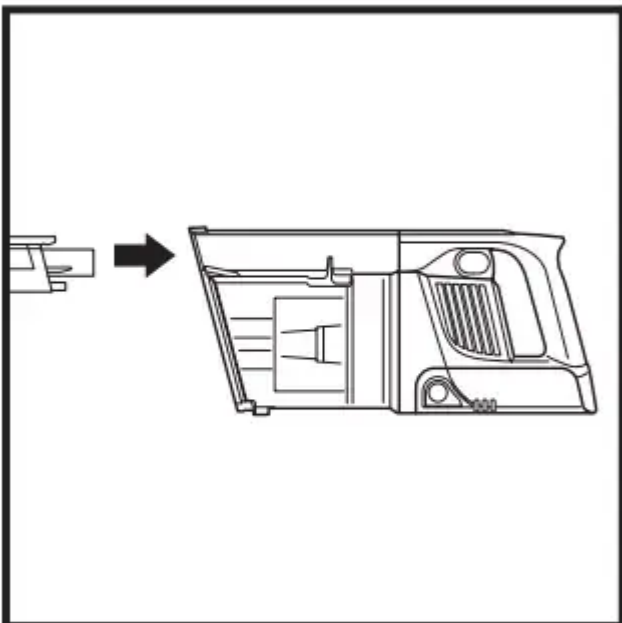

1. Turn off vacuum.
2. Remove the handheld vacuum from the wand.
3. Check all intake openings to the dust cup and remove any debris or blockage.

Checking for Blockages in the Wand:

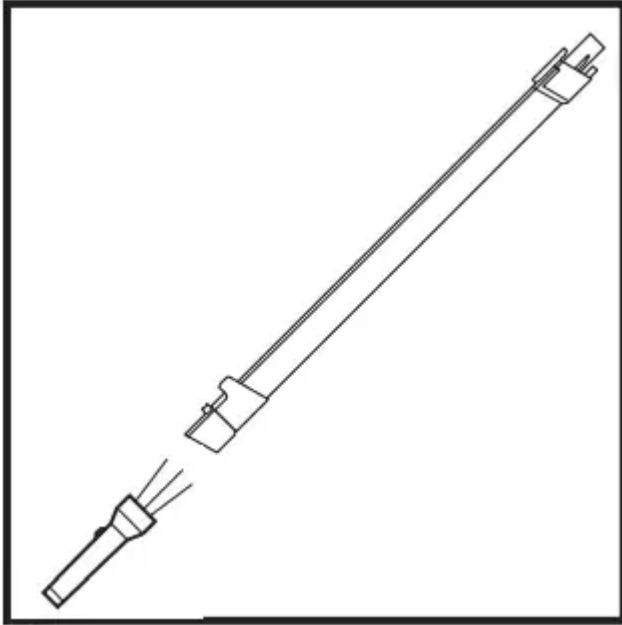

1. Turn off vacuum.
2. Remove the handheld vacuum and floor nozzle.
3. Clear away any debris and blockages inside the wand.

Checking for Blockages in the Floor Nozzle:

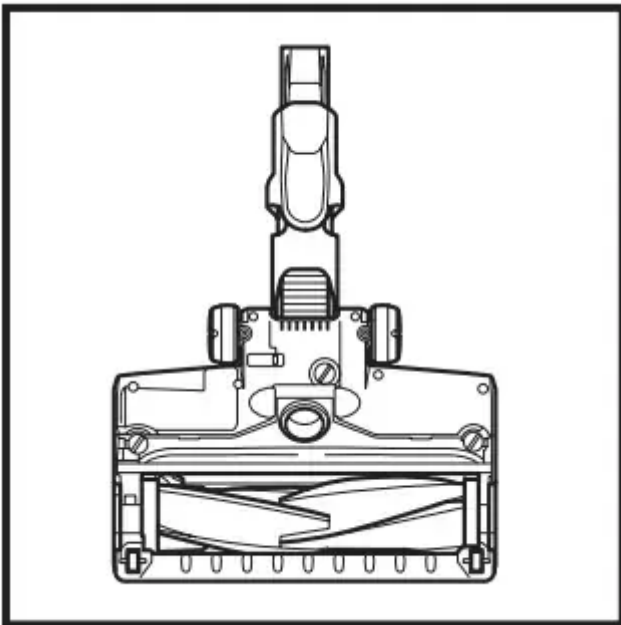

1. Turn off vacuum.
2. Detach the wand.
3. Use the edge of a coin to open the three locks on the bottom of the floor nozzle.
4. Remove the cover and tilt back the neck of the floor nozzle.
5. Check the opening and remove any debris or blockages.

6. Replace cover by firmly pressing down on all sides and turning the locks clockwise to close.

TROUBLESHOOTING

WARNING: To reduce the risk of shock and unintended operation, turn off power and remove the battery before servicing.

Vacuum is not picking up debris. No suction or light suction. Nozzle light is red. (Refer to Checking for Blockages section for more information.)

- Dust cup may be full; empty dust cup.
- Check floor nozzle for blockages; clear blockages if required.
- Remove any string, carpet fibers, or hair that may be wrapped around the brushroll.
- Check connection between handheld vacuum and wand for blockages; clear blockages if required.
- Check clog access in wand for any blockages and clear any debris.
- Check filters to see if they need cleaning. Follow instructions for rinsing and completely air-drying the filters before reinserting in the vacuum.

Vacuum lifts area rugs.

- Make sure you are not engaging Boost mode. Take care when vacuuming area rugs or rugs with delicately sewn edges.
- Turn off the unit to disengage the brushroll and restart with the power/selector switch.

Brushroll does not spin.

- Immediately turn off the vacuum. Remove any blockages before turning the vacuum back on. Make sure the handheld vacuum is tilted back far enough for the brushroll to engage while in use.
- If the floor nozzle has headlights and they are not illuminated, there is a connection issue between the handheld vacuum, wand, and nozzle. Try disconnecting and reattaching the pieces.

Vacuum turns off on its own.

There are several possible reasons for the vacuum turning off on its own, including blockages, battery issues, and overheating. If vacuum turns off on its own, perform the following steps:

1. Turn on the vacuum and check the battery indicator lights located on the handheld vacuum. If recharging is needed, plug in while the power/selector switch is in the off position.
2. Empty dust cup and clean filters (See Emptying the Dust Cup and Cleaning the Filters sections).

3. Check wand, accessories, and inlet openings and remove any blockages.
4. Allow unit and battery to cool for at least 45 minutes, until they return to room temperature.
5. Restart with power-selector switch.

NOTE: If vacuum still does not operate properly, contact Customer Service at 1-800-798-7398.

Battery Indicator Lights on handheld vacuum are flashing.

- Bottom LED light is flashing (Fig. A): Battery needs to be charged.
- Top and bottom LED lights are flashing (Fig. B): Battery temperature is not optimal, so charging is temporarily paused. Leave battery plugged in and charging will resume soon.
- If top 2 or bottom 2 LED lights are flashing (Fig. C, Fig. D), call Customer Service at 1-800-798-7398.

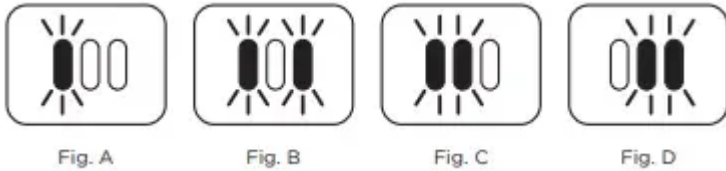

ACCESSORIES

- A. Crevice Tool
- B. 18-inch Flexi Crevice Tool
- C. Duster Crevice Tool
- D. Dusting Brush
- E. Multi-Angle Dusting Brush
- F. Anti-Allergen Dust Brush
- G. Upholstery Tool
- H. Wide Upholstery Tool
- I. Pet Multi-Tool
- J. Deep-Cleaning Motorized Pet Tool
- K. MultiFLEX® Under-Appliance Wand
- L. Accessory Bag
- M. Li-Ion Charger

A



B



C



D

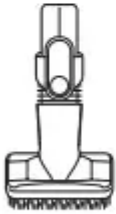

E

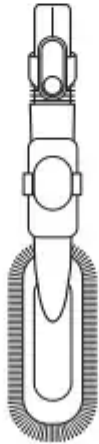

F



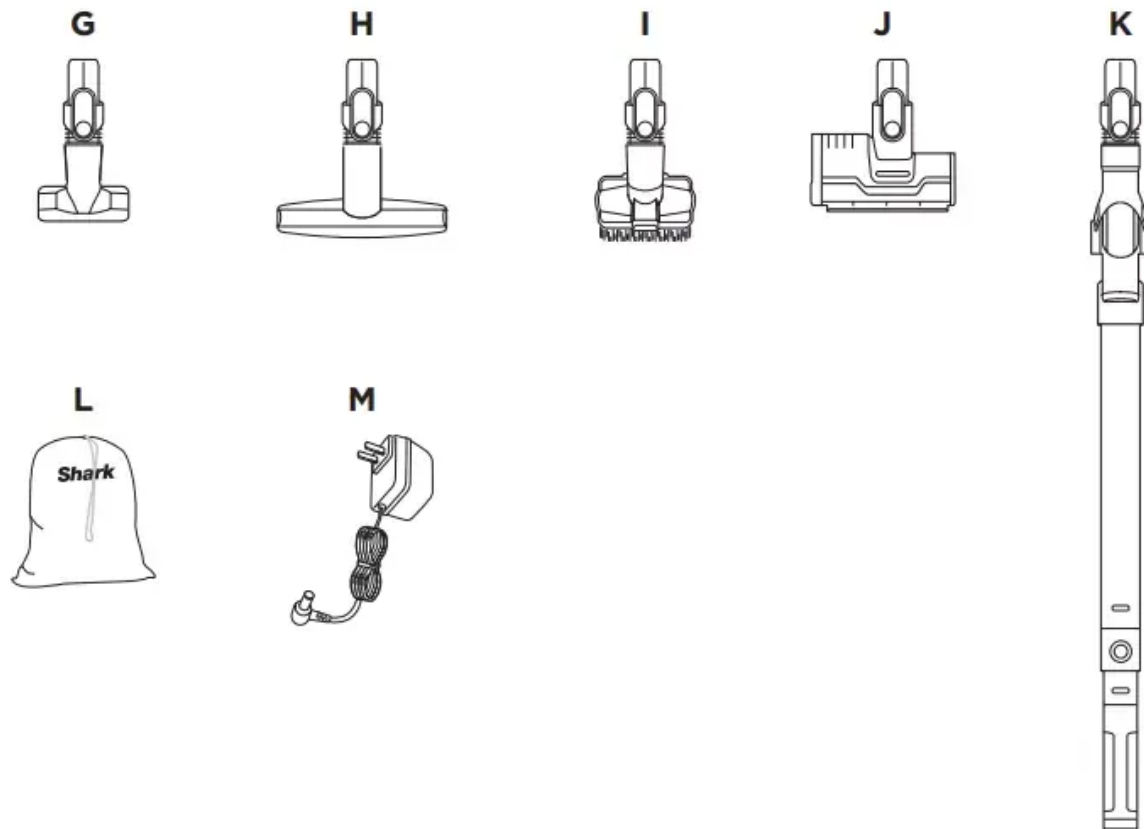

NOTE: Not all accessories come with all units. For a list of the accessories included with this model, see the enclosed Quick Start Guide. To order additional accessories, visit sharkaccessories.com.

FIVE (5) YEAR LIMITED WARRANTY

1. The original unit and/or non-wearable components deemed defective, in SharkNinja's sole discretion, will be repaired or replaced up to five (5) years from the original purchase date.
2. In the event a replacement unit is issued, the warranty coverage ends six (6) months following the receipt date of the replacement unit or the remainder of the existing warranty, whichever is later. SharkNinja reserves the right to replace the unit with one of equal or greater value.

What is not covered by this warranty?

1. Normal wear and tear of wearable parts (such as foam filters, HEPA filters, pads, etc.), which require regular maintenance and/or replacement to ensure the proper functioning of your unit, are not covered by this warranty. Replacement parts are available for purchase at sharkaccessories.com.
2. Any unit that has been tampered with or used for commercial purposes.

3. Damage caused by misuse (e.g., vacuuming up water or other liquids), abuse, negligent handling, failure to perform required maintenance (e.g., not cleaning the filters), or damage due to mishandling in transit.
4. Consequential and incidental damages.
5. Defects caused by repair persons not authorized by SharkNinja. These defects include damages caused in the process of shipping, altering, or repairing the SharkNinja product (or any of its parts) when the repair is performed by a repair person not authorized by SharkNinja.
6. Products purchased, used, or operated outside North America.

How to get service

If your appliance fails to operate properly while in use under normal household conditions within the warranty period, visit sharkclean.com/support for product care and maintenance self-help. Our Customer Service Specialists are also available at 1-800-798-7398 to assist with product support and warranty service options, including the possibility of upgrading to our VIP warranty service options for select product categories. We also ask that you register your product online at registeryourshark.com and have the product on hand when you call, so we may better assist you.

SharkNinja will cover the cost for the customer to send in the unit to us for repair or replacement. A fee of \$25.95 (subject to change) will be charged when SharkNinja ships the repaired or replacement unit.

How to initiate a warranty claim

You must call 1-800-798-7398 to initiate a warranty claim. In order to better assist you please register your product prior to calling and have your product with you at the time of your call. You will need the receipt as proof of purchase. A Customer Service Specialist will provide you with return and packing instruction information. We also ask that you register your product online at registeryourshark.com and have the product on hand when you call, so we may better assist you.

How state law applies

This warranty gives you specific legal rights, and you also may have other rights that vary from state to state. Some states do not permit the exclusion or limitation of incidental or consequential damages, so the above may not apply to you.

TWO (2) YEAR LIMITED BATTERY WARRANTY

1. The original battery deemed defective, in SharkNinja's sole discretion, will be replaced up to two (2) years from the original purchase date.
2. In the event a replacement battery is issued, the warranty coverage ends six (6) months following the receipt date of the replacement battery or the remainder of the existing

warranty, whichever is later. SharkNinja reserves the right to replace the unit with one of equal or greater value.

What is not covered by this warranty?

1. Normal wear and tear of the battery, which requires optimal temperature storage and operation to ensure its proper functioning. Replacement batteries are available for purchase at sharkclean.com/batteries.
2. A battery that has been tampered with or used for commercial purposes.
3. Damage caused by misuse (e.g., exposing battery to liquids or extreme hot and/or cold temperatures), abuse, negligent handling, failure to perform required maintenance, (e.g., not cleaning the filters, not removing debris from the brushroll) or damage due to mishandling in transit.
4. Consequential and incidental damages.
5. Defects caused by repair persons not authorized by SharkNinja. These defects include damages caused in the process of shipping, altering, or repairing the SharkNinja product (or any of its parts) when the repair is performed by a repair person not authorized by SharkNinja.
6. Products purchased, used, or operated outside North America.

How to get service

If your battery fails to operate properly while in use under normal household conditions within the warranty period, visit sharkclean.com/support for product care and maintenance self-help. Our Customer Service Specialists are also available at 1-800-798-7398 to assist with product support and warranty service options. So we may better assist you, please register your product online at registeryourshark.com and have the product on hand when you call.

SharkNinja will cover the cost for the customer to send in the unit to us for replacement. A fee of \$19.95 (subject to change) will be charged when SharkNinja ships the replacement unit.

How to initiate a warranty claim

You must call 1-800-798-7398 to initiate a warranty claim. You will need the receipt as proof of purchase. We also ask that you register your product online at registeryourshark.com and have the product on hand when you call, so we may better assist you. A Customer Service Specialist will provide you with return and packing instruction information when you call.

How state law applies

This warranty gives you specific legal rights, and you also may have other rights that vary from state to state. Some states do not permit the exclusion or limitation of incidental or consequential damages, so the above may not apply to you.

TECHNICAL SPECIFICATIONS

Voltage: 21.6V Watts: 181W

BATTERY REMOVAL AND DISPOSAL

This product uses a lithium-ion rechargeable and recyclable battery. When the battery no longer holds a charge, it should be removed from the vacuum and recycled. DO NOT incinerate or compost the battery.

When your lithium-ion battery needs to be replaced, dispose of it or recycle it in accordance with local ordinances or regulations. In some areas, it is illegal to place spent lithium-ion batteries in the trash or in a municipal solid waste stream. Return spent battery to an authorized recycling center or to retailer for recycling. Contact your local recycling center for information on where to drop off the spent battery.

The RBRC (Rechargeable Battery Recycling Corporation) seal on the lithium-ion battery indicates that the costs to recycle the battery at the end of its useful life have already been paid by SharkNinja. In some areas, it is illegal to place spent lithium-ion batteries in the trash or municipal solid waste stream and the RBRC program provides an environmentally conscious alternative.

RBRC, in cooperation with SharkNinja and other battery users, has established programs in the United States and Canada to facilitate the collection of spent lithium-ion batteries. Help protect our environment and conserve natural resources by returning the spent lithium-ion battery to an authorized SharkNinja service center or to your local retailer for recycling. You may also contact your local recycling center for information on where to drop off the spent battery, or call 1-800-798-7398.

FCC INFORMATION

1. This device may not cause harmful interference, and
2. This device must accept any interference received, including interference that may cause undesired operation.

PLEASE READ CAREFULLY AND KEEP FOR FUTURE REFERENCE.

This Owner's Guide is designed to help you get a complete understanding of your new Shark® Rocket® PowerFins® Cordless Vacuum.

SharkNinja Operating LLC US: Needham, MA 02494 CAN: Ville St-Laurent, QC H4S 1A7
1-800-798-7398
sharkclean.com

Illustrations may differ from actual product. We are constantly striving to improve our products; therefore the specifications contained herein are subject to change without notice.

This product may be covered by one or more U.S. patents. See sharkninja.com/patents for more information.

Warning

This content is compiled from multiple sources and is provided for reference purposes only. It may not be complete or fully applicable to all situations. If you are unable to resolve your issue, please contact the product manufacturer or an authorized service provider for official support.

Document generated by ManualsFile

