

Important Safe Operation Practices

WARNING: This symbol points out important safety instructions which, if not followed, could endanger the personal safety and/or property of yourself and others. Read and follow all instructions in this manual before attempting to operate this machine. Failure to comply with these instructions may result in personal injury. When you see this symbol. **HEED ITS WARNING!**

WARNING: Engine Exhaust, some of its constituents, and certain vehicle components contain or emit chemicals known to State of California to cause cancer and birth defects or other reproductive harm.

WARNING: Battery posts, terminals, and related accessories contain lead and lead compounds, chemicals known to the State of California to cause cancer and reproductive harm. Wash hands after handling.

DANGER: This machine was built to be operated according to the safe operation practices in this manual. As with any type of power equipment, carelessness or error on the part of the operator can result in serious injury. This machine is capable of amputating fingers, hands, toes and feet and throwing objects. Failure to observe the following safety instructions could result in serious injury or death.

General Operation

1. Read this operator's manual carefully in its entirety before attempting to assemble this machine. Read, understand, and follow all instructions on the machine and in the manual(s) before operation. Keep this manual in a safe place for future and regular reference and for ordering replacement parts.
2. Be completely familiar with the controls and the proper use of this machine before operating it.
3. This machine is a precision piece of power equipment, not a plaything. Therefore, exercise extreme caution at all times. This machine has been designed to perform one job: to mow grass. Do not use it for any other purpose.
4. Never allow children under 14 years of age to operate this machine. Children 14 and over should read and understand the instructions and safe operation practices in this manual and on the machine and should be trained and supervised by an adult.
5. Only responsible individuals who are familiar with these rules of safe operation should be allowed to use this machine.

6. Thoroughly inspect the area where the equipment is to be used. Remove all stones, sticks, wire, bones, toys and other foreign objects, which could be tripped over or picked up and thrown by the blade. Thrown objects can cause serious personal injury.
7. Plan your mowing pattern to avoid discharge of material toward roads, sidewalks, bystanders and the like. Also, avoid discharging material against a wall or obstruction, which may cause discharged material to ricochet back toward the operator.
8. To help avoid blade contact or a thrown object injury, stay in operator zone behind handles and keep children, bystanders, helpers and pets at least 75 feet from mower while it is in operation. Stop machine if anyone enters area.
9. Always wear safety glasses or safety goggles during operation and while performing an adjustment or repair to protect your eyes. Thrown objects which ricochet can cause serious injury to the eyes.
10. Wear sturdy, rough-soled work shoes and close-fitting slacks and shirts. Shirts and pants that cover the arms and legs and steel-toed shoes are recommended. Never operate this machine in bare feet, sandals, slippery or light-weight (e.g. canvas) shoes.
11. Do not put hands or feet near rotating parts or under the cutting deck. Contact with blade can amputate fingers, hands, toes and feet.
12. A missing or damaged discharge cover can cause blade contact or thrown object injuries.
13. Many injuries occur as a result of the mower being pulled over the foot during a fall caused by slipping or tripping. Do not hold on to the mower if you are falling; release the handle immediately.
14. Never pull the mower back toward you while you are walking. If you must back the mower away from a wall or obstruction first look down and behind to avoid tripping and then follow these steps:
 - a. Step back from mower to fully extend your arms.
 - b. Be sure you are well balanced with sure footing.
 - c. Pull the mower back slowly, no more than half way toward you.
 - d. Repeat these steps as needed.
15. Do not operate the mower while under the influence of alcohol or drugs.
16. Do not engage the self-propelled mechanism on machines so equipped while starting engine.
17. The blade control is a safety device. Never attempt to bypass its operation. Doing so makes the safety device inoperative and may result in personal injury through contact with the rotating blade. The blade control must operate easily in both directions and automatically return to the disengaged position when released.

18. Never operate the mower in wet grass. Always be sure of your footing. A slip and fall can cause serious personal injury. If you feel you are losing your footing, release the blade control handle immediately and the blade will stop rotating within three seconds.
19. Mow only in daylight or good artificial light. Walk, never run.
20. Stop the blade when crossing gravel drives, walks or roads.
21. If the equipment should start to vibrate abnormally, stop the engine and check immediately for the cause. Vibration is generally a warning of trouble.
22. Shut the engine off and wait until the blade comes to a complete stop before removing the grass catcher or unclogging the chute. The cutting blade continues to rotate for a few seconds after the blade control is released. Never place any part of the body in the blade area until you are sure the blade has stopped rotating.
23. Never operate mower without proper trail shield, discharge cover, grass catcher, blade control or other safety protective devices in place and working. Never operate mower with damaged safety devices. Failure to do so can result in personal injury.
24. Muffler and engine become hot and can cause a burn. Do not touch.
25. Never attempt to make a wheel or cutting height adjustment while the engine is running.
26. Only use parts and accessories made for this machine by the manufacturer. Failure to do so can result in personal injury.
27. When starting engine, pull cord slowly until resistance is felt, then pull rapidly. Rapid retraction of starter cord (kickback) will pull hand and arm toward engine faster than you can let go. Broken bones, fractures, bruises or sprains could result.
28. If situations occur which are not covered in this manual, use care and good judgement. Contact Customer Support for assistance or the name of the nearest service dealer.

Slope Operation

Slopes are a major factor related to slip and fall accidents, which can result in severe injury. Operation on slopes requires extra caution. If you feel uneasy on a slope, do not mow it. For your safety, use the slope gauge included as part of this manual to measure slopes before operating this machine on a sloped or hilly area. If the slope is greater than 15 degrees, do not mow it.

Do:

1. Mow across the face of slopes; never up and down. Exercise extreme caution when changing direction on slopes.
2. Watch for holes, ruts, rocks, hidden objects, or bumps which can cause you to slip or trip. Tall grass can hide obstacles.

3. Always be sure of your footing. A slip and fall can cause serious personal injury. If you feel you are losing your balance, release the blade control handle immediately and the blade will stop rotating within three (3) seconds.

Do Not:

1. Do not mow near drop-offs, ditches or embankments, you could lose your footing or balance.
2. Do not mow slopes greater than 15 degrees as shown on the slope gauge.
3. Do not mow on wet grass. Unstable footing could cause slipping.

Children

Tragic accidents can occur if the operator is not alert to the presence of children. Children are often attracted to the mower and the mowing activity. They do not understand the dangers. Never assume that children will remain where you last saw them.

1. Keep children out of the mowing area and under watchful care of a responsible adult other than the operator.
2. Be alert and turn mower off if a child enters the area.
3. Before and while mowing backwards, look behind and down for small children.
4. Use extreme care when approaching blind corners, doorways, shrubs, trees, or other objects that may obscure your vision of a child who may run into the mower.
5. Keep children away from hot or running engines. They can suffer burns from a hot muffler.
6. Never allow children under 14 years of age to operate this machine. Children 14 and over should read and understand the instructions and safe operation practices in this manual and on the machine and be trained and supervised by an adult.

Safe Handling of Gasoline

1. To avoid personal injury or property damage use extreme care in handling gasoline. Gasoline is extremely flammable and the vapors are explosive. Serious personal injury can occur when gasoline is spilled on yourself or your clothes, which can ignite. Wash your skin and change clothes immediately.
2. Use only an approved gasoline container.
3. Never fill containers inside a vehicle or on a truck or trailer bed with a plastic liner. Always place containers on the ground away from your vehicle before filling.
4. Remove gas-powered equipment from the truck or trailer and refuel it on the ground. If this is not possible, then refuel such equipment on a trailer with a portable container, rather than from a gasoline dispenser nozzle.

5. Keep the nozzle in contact with the rim of the fuel tank or container opening at all times until fueling is complete. Do not use a nozzle lock-open device.
6. Extinguish all cigarettes, cigars, pipes and other sources of ignition.
7. Never fuel machine indoors because flammable vapors will accumulate in the area.
8. Never remove gas cap or add fuel while engine is hot or running. Allow engine to cool at least two minutes before refueling.
9. Never over fill fuel tank. Fill tank to no more than 1 inch below bottom of filler neck to provide for fuel expansion.
10. Replace gasoline cap and tighten securely.
11. If gasoline is spilled, wipe it off the engine and equipment. Move machine to another area. Wait 5 minutes before starting engine.
12. Never store the machine or fuel container near an open flame, spark or pilot light as on a water heater, space heater, furnace, clothes dryer or other gas appliances.
13. To reduce fire hazard, keep machine free of grass, leaves, or other debris build-up. Clean up oil or fuel spillage and remove any fuel soaked debris.
14. Allow machine to cool at least 5 minutes before storing.

General Service

1. Never run an engine indoors or in a poorly ventilated area. Engine exhaust contains carbon monoxide, an odorless and deadly gas.
2. Before cleaning, repairing, or inspecting, make certain the blade and all moving parts have stopped. Disconnect the spark plug wire and ground against the engine to prevent unintended starting.
3. Check the blade and engine mounting bolts at frequent intervals for proper tightness. Also, visually inspect blade for damage (e.g., bent, cracked, worn) Replace blade with the original equipment manufacture's (O.E.M.) blade only, listed in this manual. "Use of parts which do not meet the original equipment specifications may lead to improper performance and compromise safety!"
4. Mower blades are sharp and can cut. Wrap the blade or wear gloves, and use extra caution when servicing them.
5. Keep all nuts, bolts, and screws tight to be sure the equipment is in safe working condition.
6. Never tamper with safety devices. Check their proper operation regularly.
7. After striking a foreign object, stop the engine, disconnect the spark plug wire and ground against the engine. Thoroughly inspect the mower for any damage. Repair the damage before starting and operating the mower.

8. Never attempt to make a wheel or cutting height adjustment while the engine is running.
9. Grass catcher components, discharge cover, and trail shield are subject to wear and damage which could expose moving parts or allow objects to be thrown. For safety protection, frequently check components and replace immediately with original equipment manufacturer's (O.E.M.) parts only, listed in this manual. "Use of parts which do not meet the original equipment specifications may lead to improper performance and compromise safety!"
10. Do not change the engine's governor setting or over-speed the engine. The governor controls the maximum safe operating speed of the engine.
11. Check fuel line, tank, cap, and fittings frequently for cracks or leaks. Replace if necessary.
12. Do not crank engine with spark plug removed.
13. Maintain a repair safety and instruction labels, as necessary.
14. Observe proper disposal laws and regulations. Improper disposal of fluids and materials can harm the environment.
15. According to the Consumer Products Safety Commission (CPSC) and the U.S. Environmental Protection Agency (EPA), this product has an Average Useful Life of seven (7) years, or 140 hours of operation. At the end of the Average Useful Life have the machine inspected annually by an authorized service dealer to ensure that all mechanical and safety systems are working properly and not worn excessively. Failure to do so can result in accidents, injuries or death.

Do not modify engine

To avoid serious injury or death, do not modify engine in any way. Tampering with the governor setting can lead to a runaway engine and cause it to operate at unsafe speeds. Never tamper with factory setting of engine governor.

Notice Regarding Emissions

Engines which are certified to comply with California and federal EPA emission regulations for SORE (Small Off Road Equipment) are certified to operate on regular unleaded gasoline, and may include the following emission control systems: Engine Modification (EM), Oxidizing Catalyst (OC), Secondary Air Injection (SAI) and Three Way Catalyst (TWC) if so equipped.

Spark Arrestor

WARNING: This machine is equipped with an internal combustion engine and should not be used on or near any unimproved forest- covered, brush covered or grass- covered land unless the

engine's exhaust system is equipped with a spark arrestor meeting applicable local or state laws (if any).

If a spark arrestor is used, it should be maintained in effective working order by the operator. In the State of California the above is required by law (Section 4442 of the California Public Resources Code). Other states may have similar laws. Federal laws apply on federal lands. A spark arrestor for the muffler is available through your nearest engine authorized service dealer or contact the service department, P.O. Box 361131 Cleveland, Ohio 44136- 0019.

Safety Symbols

Symbol	Description
READ THE OPERATOR'S MANUAL(S)	Read, understand, and follow all instructions in the manual(s) before attempting to assemble and operate
DANGER — ROTATING BLADES	To reduce the risk of injury, keep hands and feet away. Do not operate unless discharge cover or grass catcher is in its proper place. If damaged, replace immediately.
DANGER — BYSTANDERS	Do not mow when children or others are around.
DANGER — HAND/ FOOT CUT	Keep hands and feet away from rotating parts.
DANGER — THROWN DEBRIS	Remove objects that can be thrown by the blade in any direction. Wear safety glasses.
DANGER — SLOPES	Use extra caution on slopes. Do not mow slopes greater than 15°.
WARNING — GASOLINE IS FLAMMABLE	Allow the engine to cool at least two minutes before refueling.
WARNING — CARBON MONOXIDE	Never run an engine indoors or in a poorly ventilated area. Engine exhaust contains carbon monoxide, an odorless and deadly gas.
WARNING — HOT SURFACE	Engine parts, especially the muffler, become extremely hot during operation. Allow engine and muffler to cool before touching.

WARNING: Your Responsibility—Restrict the use of this power machine to persons who read, understand and follow the warnings and instructions in this manual and on the machine.



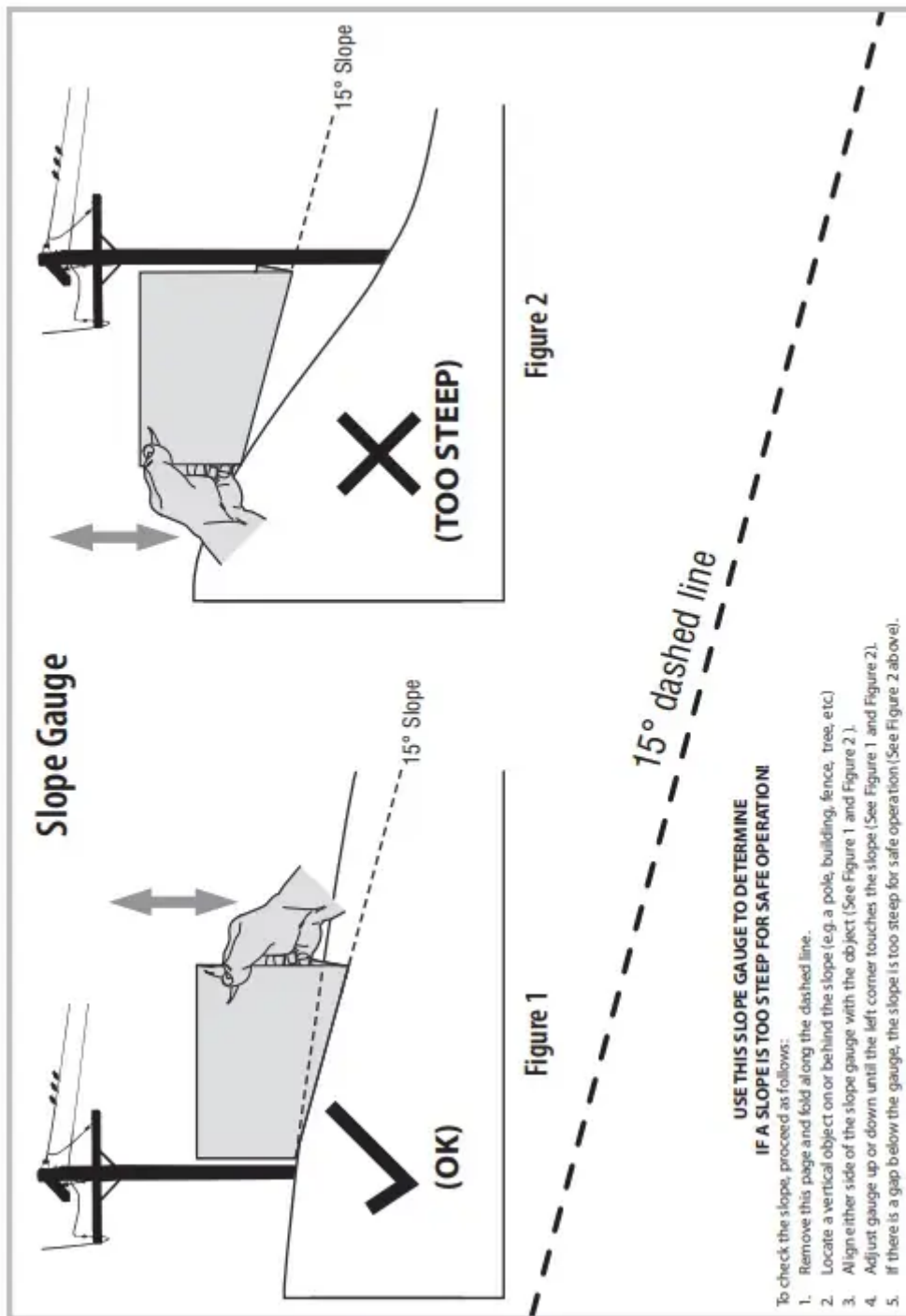

WARNING! Slopes are a major factor related to tip-over and roll-over accidents which can result in severe injury or death.

Do not operate machine on slopes in excess of 15 degrees. All slopes require extra caution. Always mow across the face of slopes, never up and down slopes.

Contents of Carton

- One Lawn Mower
- One Grass Catcher
- One Bottle of Oil

- One Lawn Mower Operator's Manual
- One Engine Operator's Manual
- One Side Discharge Chute

NOTE: Please be aware that this Operator's Manual covers both the low and high wheel models of this mower. While this manual illustrates the high wheel model, the instructions and features are equally applicable to the low wheel model as well, unless otherwise noted.

Assembly and Setup

Assembly

NOTE: This unit is shipped without gasoline or oil in the engine. Fill up with gasoline and oil as instructed in the accompanying engine manual BEFORE operating your mower.

Handle

1. Remove any packing material which may be between upper and lower handles.
 - a. Remove wing nuts and carriage bolts from handle as shown in Fig. 3-1. Do not loosen or remove adjacent hex head screws.

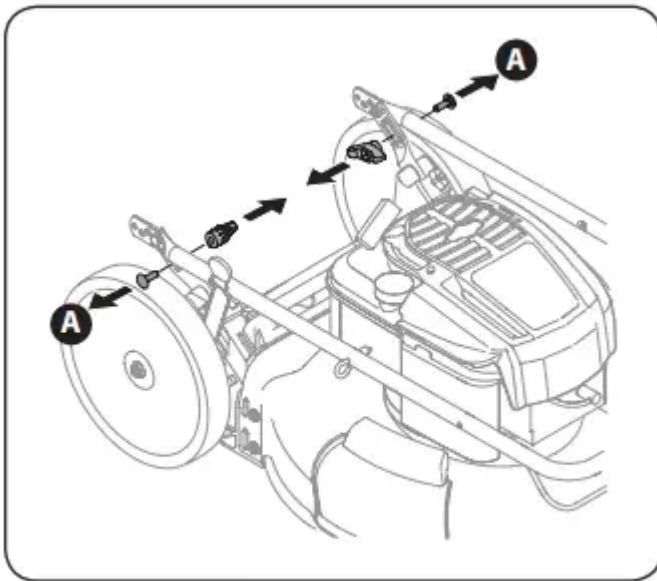

Figure 3-1

- b. While stabilizing mower so it doesn't move, pivot upper handle up as shown in Fig.

3-2. Do not crimp cable while lifting the handle up.

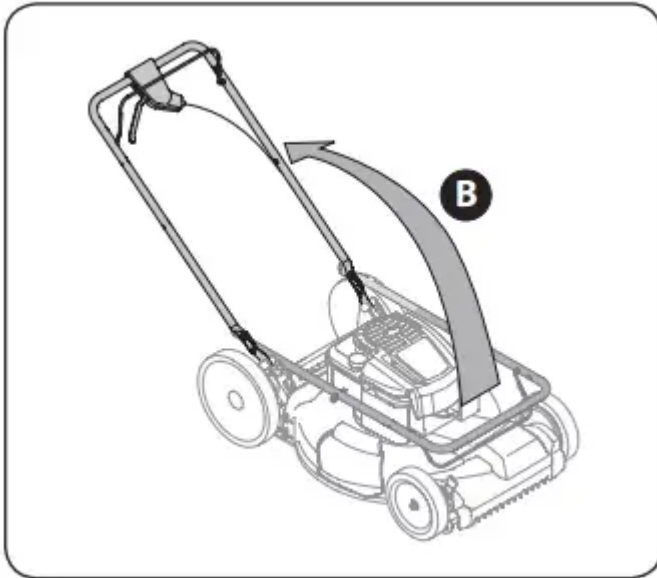

Figure 3-2

2. Remove the T-bolts from the handle brackets as shown in Fig. 3-3.

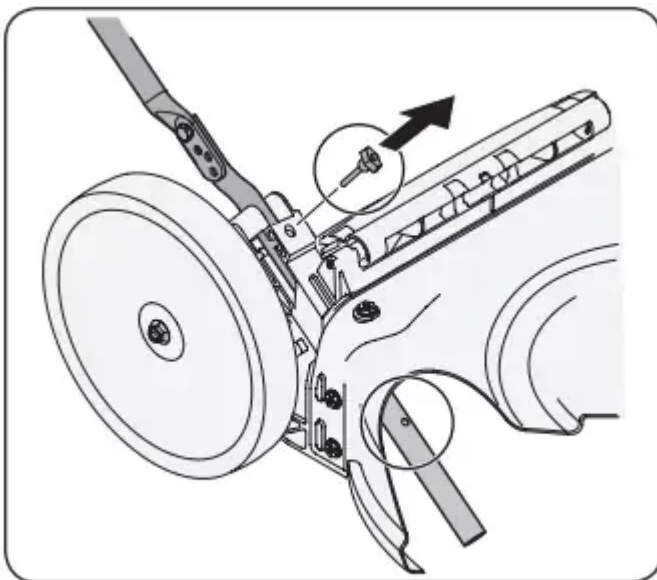

Figure 3-3

3. Follow the steps below to complete handle assembly:

- a. Pull upward on the handle until holes in lower handle (shown in Fig. 3-3 deck cutaway) line up with holes in handle bracket. See Fig. 3-4.



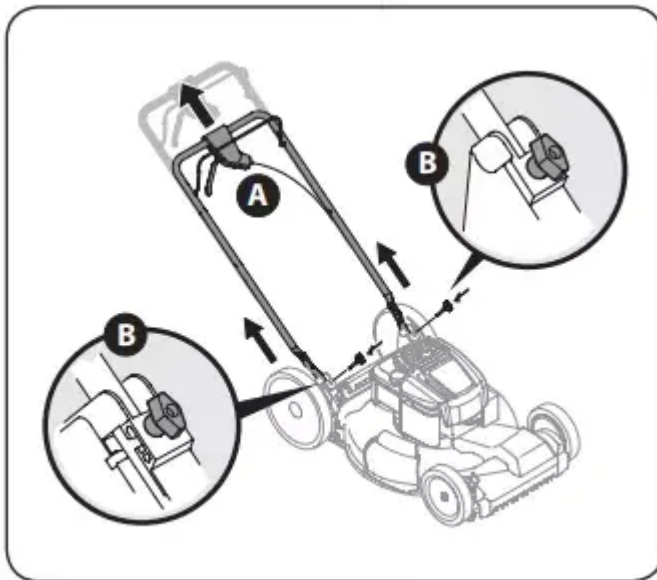

Figure 3-4

NOTE: When pulling upward on handle, make sure to not pull handle all the way out.

b. Insert the T-bolts removed earlier through the handle brackets and lower handle and tighten securely to secure the handle in place. See Fig. 3-4.

c. Reattach wing nuts and carriage bolts removed earlier into lower holes of handle as shown in Fig. 3-5.

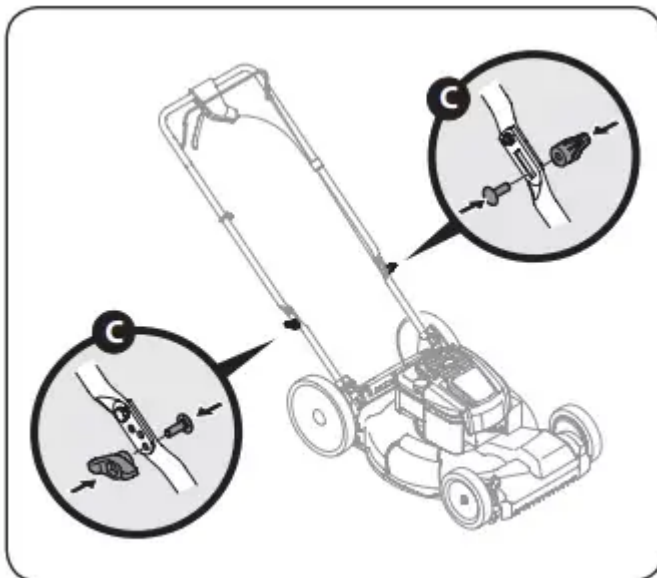

Figure 3-5

4. The rope guide is attached to the right side of the upper handle. Loosen the wing knob which secures the rope guide. See Fig. 3-6.

a. Hold blade control against upper handle.

b. Slowly pull starter rope handle from engine and slip starter rope into the rope guide. See Fig. 3-6.

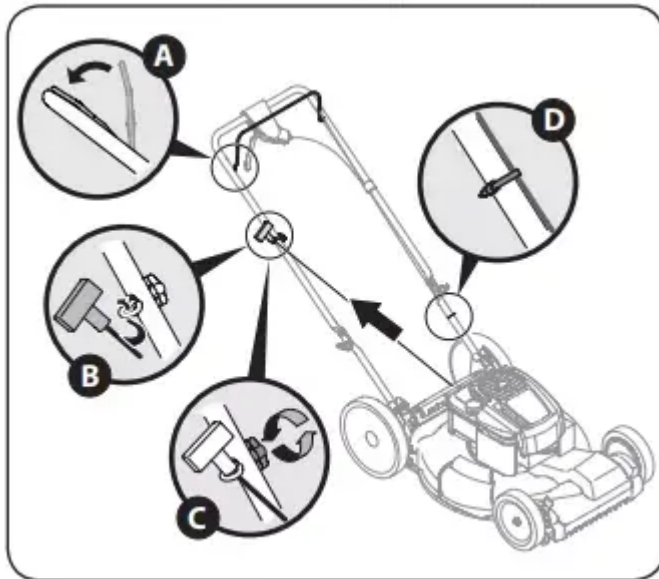

Figure 3-6

- c. Tighten rope guide wing knob.
- d. Use cable tie(s) to secure cable(s) to lower handle.

Grass Catcher

1. Follow steps below to assemble the grass catcher (if needed). Make certain bag is turned right side out before assembling (warning label will be on the outside).
 - a. Place bag over frame so that its black plastic side is at the bottom. Slip plastic channel of grass bag over hooks on the frame. See Fig. 3-7.

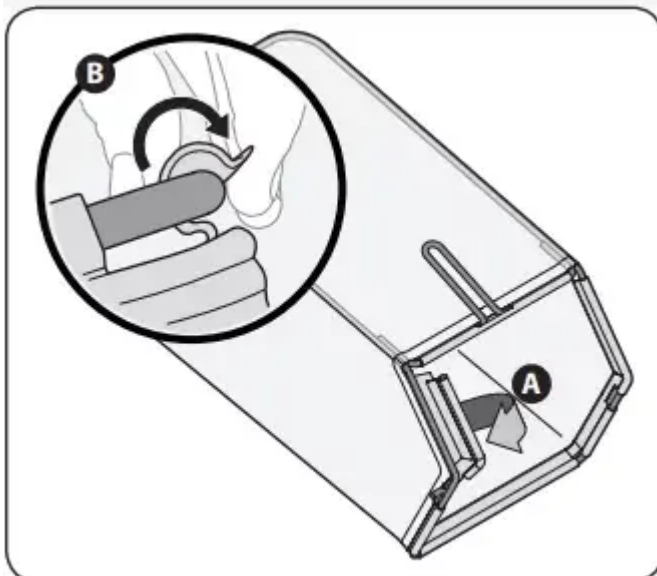

Figure 3-7

2. Follow steps below to attach grass catcher:
 - a. Lift rear discharge door.
 - b. Place grass catcher into the slots in the handle brackets as shown in Fig. 3-8. Let go of discharge door so that it rests on the grass catcher.

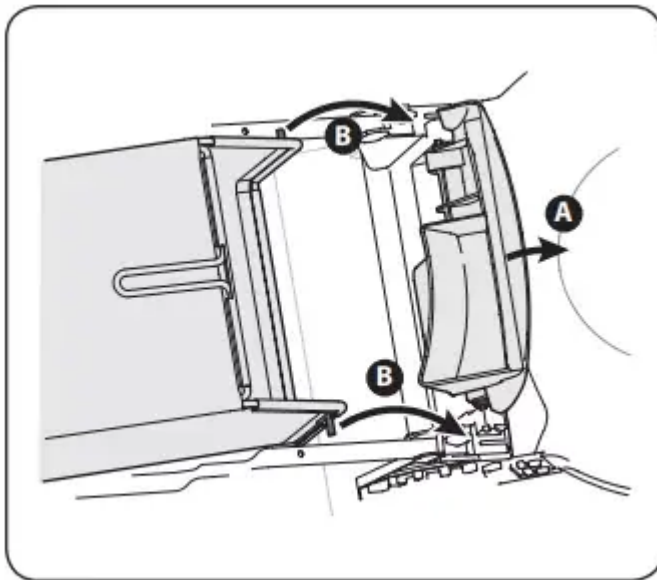

Figure 3-8

To remove grass catcher, lift rear discharge door on the mower. Lift grass catcher up and out of the slots in the handle brackets. Release rear discharge door to allow it to close rear opening of mower.

Side Discharge Chute

Your mower is shipped as a mulcher. To convert to side discharge, make sure grass catcher is off of the unit and rear discharge door is closed.

1. On the side of the mower, lift the side mulching plug. See Figure 3-9.

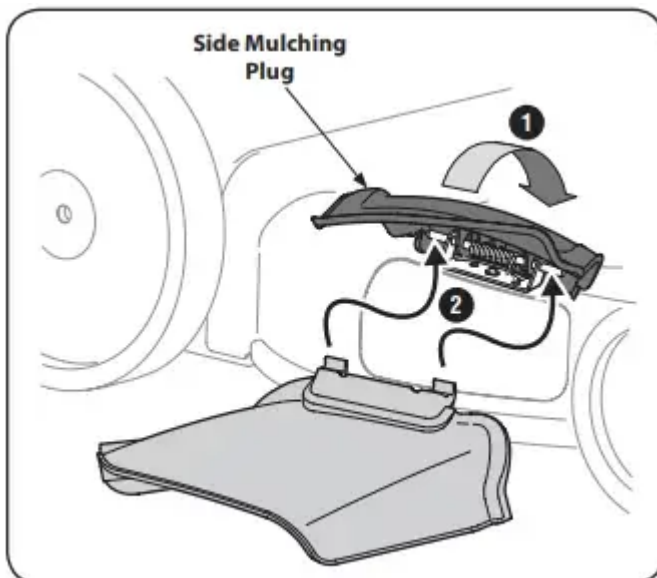

Figure 3-9

2. Slide two hooks of side discharge chute under hinge pin on mulching plug assembly. Lower the mulching plug. Do not remove side mulching plug at any time, even when you are not mulching.

Adjustments

Cutting Height

There is a cutting height adjustment lever located above the front and rear right wheel.

1. Pull the height adjustment lever towards wheel (unit will tend to fall when lever is moved outward).
2. Move lever to desired position for a change in cutting height. See Fig. 3-10 and Fig. 3-10A.

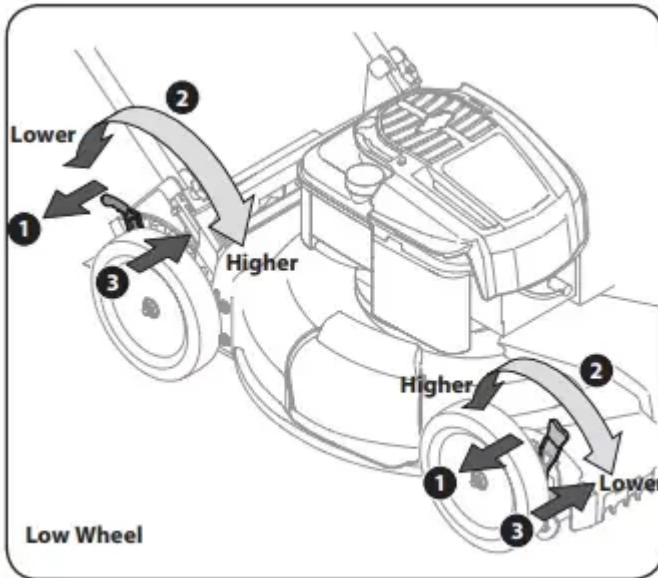

Figure 3-10

NOTE: For mowers with low wheels, the height adjustment levers move in the opposite direction to adjust; for those with high wheels, the levers move in the same direction.

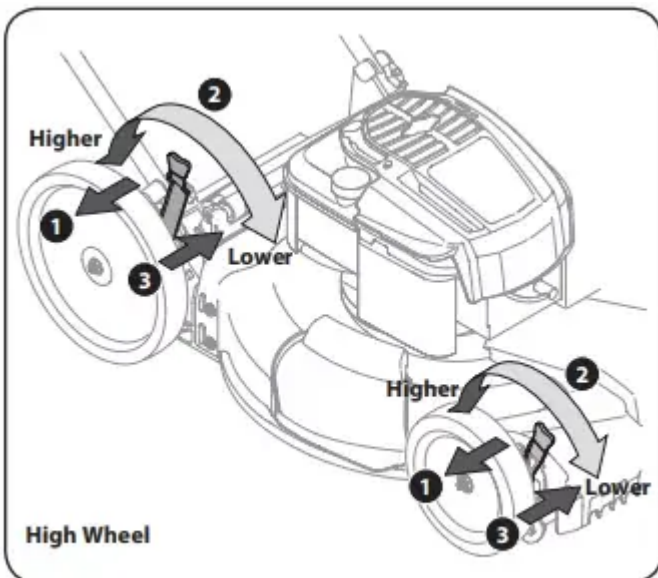

Figure 3-10A

3. Release lever towards deck.

IMPORTANT: Both the front and rear wheels must be placed in the same relative

position. For rough or uneven lawns, move the height adjustment levers to a higher position. This will stop scalping of grass.

Handle Pitch

For convenience of operation, you may adjust the pitch of the handle as follows:

1. Remove wing nuts and carriage bolts from handle. See Fig. 3-11.



Figure 3-11

2. Position the handle in one of the three positions that is most comfortable. See Fig. 3-11 inset.
3. Secure into position with wing nuts and carriage bolts removed earlier.

Drive Control

The adjustment wheel is located in the drive control handle housing and is used to tighten or loosen the drive belt. You will need to adjust the drive control if the mower does not propel itself with the drive control engaged or if the mower's wheels hesitate with the drive control engaged. If either of these conditions occur, rotate adjustment wheel clockwise to tighten cable or counterclockwise to loosen the cable. See Fig. 3-12.

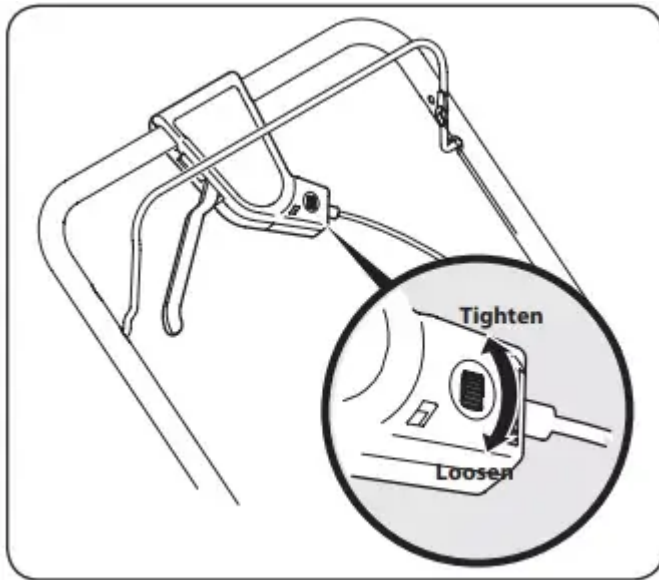

Figure 3-12

Set Up

Gas and Oil Fill-Up

Refer to the separate engine owner's manual for additional engine information.

1. Add oil provided before starting unit for the first time out of the box.
2. Service the engine with gasoline as instructed in the separate engine owner's manual.

WARNING: Use extreme care when handling gasoline. Gasoline is extremely flammable and the vapors are explosive. Never fuel the machine indoors or while the engine is hot or running. Extinguish cigarettes, cigars, pipes and other sources of ignition.

Controls & Features

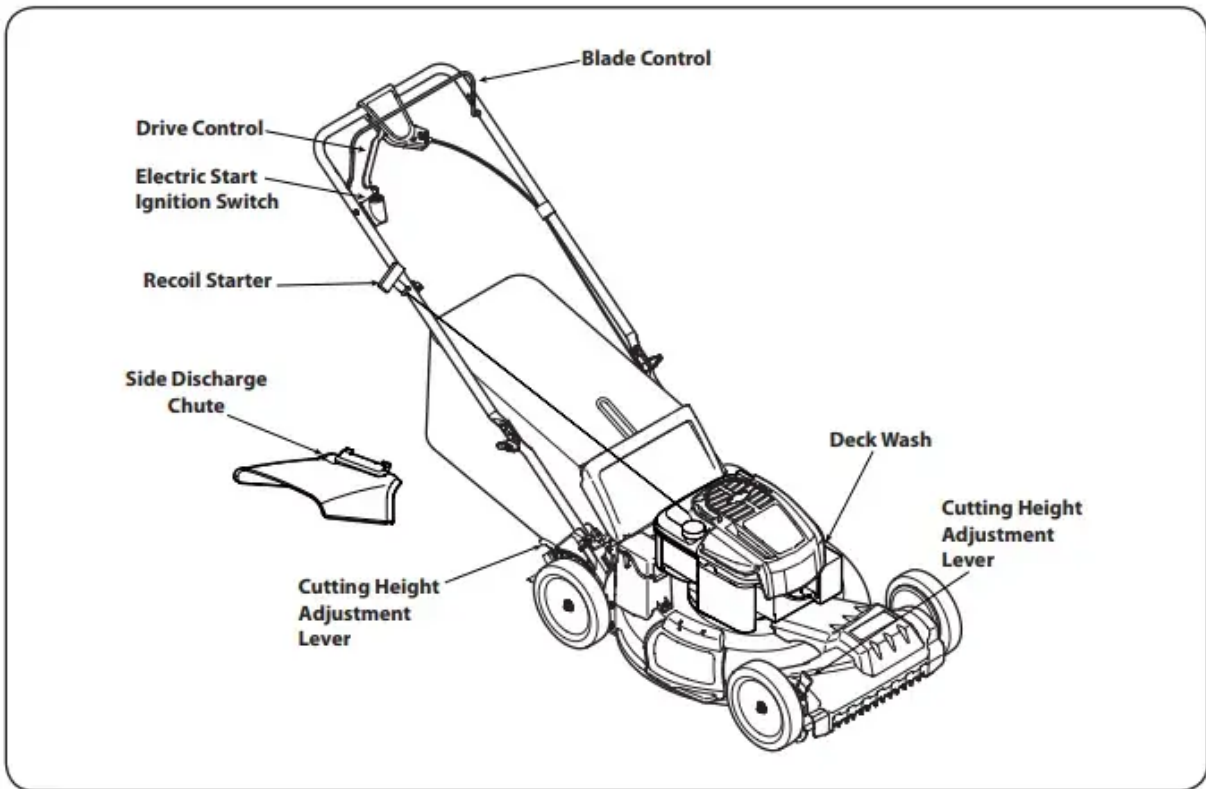

Figure 4-1

Blade Control

The blade control is attached to the upper handle of the mower. Depress and squeeze it against the upper handle to operate the unit. Release it to stop engine and blade.

WARNING: This blade control is a safety device. Never attempt to bypass its operations.

Drive Control

The drive control is located on top of the upper handle and is used to engage the drive. Squeeze it against the upper handle to engage the drive; release it to slow down or stop mower from propelling.

Cutting Height Adjustment Lever

One adjustment lever is located on the right rear wheel and one is located on the right front wheel. Both levers have to be at the same relative position to ensure a uniform cut. To adjust the cutting height, refer to the "Assembly & Set- Up" Section.

Deck Wash (If Equipped)

Your mower's deck is equipped with a water port on its surface as part of its deck wash system. Use the deck wash to rinse grass clippings from the deck's underside.

Side Discharge Chute

Your mower is shipped as a mulcher. To discharge the grass clippings to the side instead, follow the instructions in the "Assembly & Set- Up" section to attach the side discharge chute.

WARNING: Keep hands and feet away from the chute area on cutting deck. Refer to warning label on the unit.

Recoil Starter

The recoil starter is attached to the right upper handle. Stand behind the unit and pull the recoil starter rope to start the unit.

Electric Start Ignition Switch (If Equipped)

The electric start ignition switch is located on the right side of the upper handle. It is used only for the electric starter.

Operation

Starting Engine

WARNING: Be sure no one other than the operator is standing near the lawn mower while starting engine or operating mower. Never run engine indoors or in enclosed, poorly ventilated areas. Engine exhaust contains carbon monoxide, an odorless and deadly gas. Keep hands, feet, hair and loose clothing away from any moving parts on engine and lawn mower.

Follow the set of instructions pertaining to your unit. Refer to engine manual for help with the engine.

Briggs & Stratton Engine:

1. Standing behind the mower, squeeze the blade control against upper handle. See Fig. 5-1.

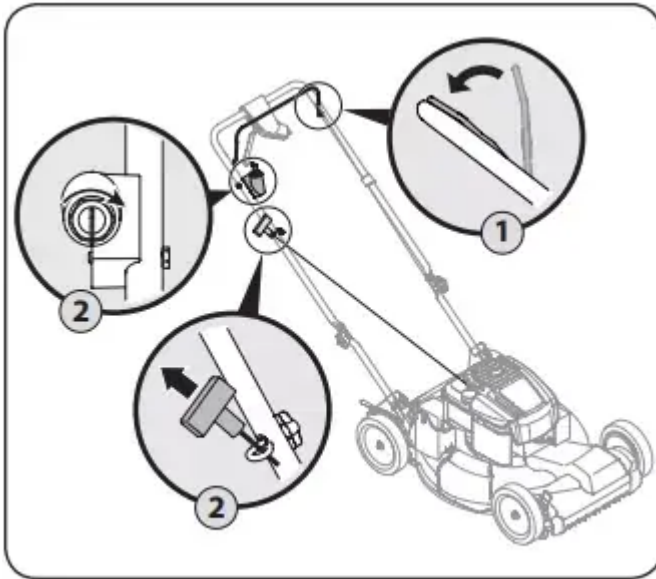

Figure 5-1

2. Recoil Start: Holding these two handles together firmly, grasp recoil starter handle and pull rope out with a rapid, continuous, full arm stroke. See Figure 5-1. Keeping a firm grip on the starter handle, let the rope rewind slowly. Repeat until engine cranks. Let the rope rewind each time slowly. Electric Start (If Equipped): Turn ignition key to the right to start the engine. Release the key after the engine starts.

Honda Engine:

1. Place the fuel valve lever found on the left side of the engine into the ON (OPEN) position. See Fig. 5-2.

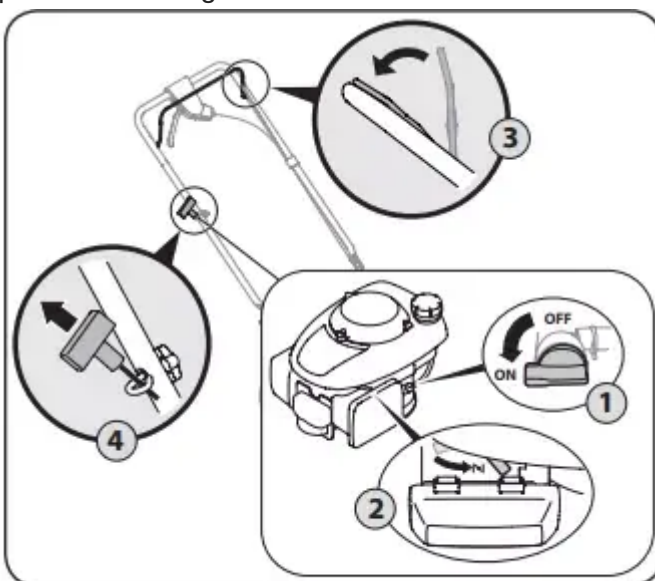

Figure 5-2

2. Move the choke lever all the way backward into the choke position.

3. Standing behind the mower, squeeze the blade control against upper handle. The choke will now begin to slowly return to the off choke position after activating the blade control. Therefore, quickly move onto step four below.
4. Holding these two handles together firmly, grasp recoil starter handle and pull rope out with a rapid, continuous, full arm stroke. See Fig. 5-2. Keeping a firm grip on the starter handle let the rope rewind slowly. Repeat until engine cranks. Let the rope rewind each time slowly.

Stopping Engine

1. Release blade control to stop the engine and blade.
WARNING: Wait for the blade to stop completely before performing any work on the mower or to remove the grass catcher.

Using Your Lawn Mower

Be sure lawn is clear of stones, sticks, wire, or other objects which could damage lawn mower or engine. Such objects could be accidentally thrown by the mower in any direction and cause serious personal injury to the operator and others.

1. Once the engine is running, squeeze the driver control against the upper handle to propel mower.
WARNING: The operation of any lawn mower can result in foreign objects being thrown into the eyes, which can damage your eyes severely. Always wear safety glasses while operating the mower, or while performing any adjustments or repairs on it.

Using as Mulcher

For mulching grass, remove the grass catcher and allow the rear discharge door to close the rear opening of mower. For effective mulching, do not cut wet grass. If the grass has been allowed to grow in excess of four inches, mulching is not recommended. Use the grass catcher to bag clippings instead.

Using Grass Catcher

You can use the grass catcher to collect clippings while you are operating the mower.

1. Attach grass catcher following instructions in the "Assembly & Set-Up" section. Grass clippings will automatically collect in bag as you run mower. Operate mower till grass bag is full.
2. Stop engine completely by releasing the blade control. Make sure that the unit has come to a complete stop.
3. Lift discharge door and pull grass bag up and away from the mower to remove the bag. Dispose of the grass clippings and reinstall the bag when complete.

WARNING: If you strike a foreign object, stop the engine. Remove wire from the spark plug, thoroughly inspect mower for any damage, and repair damage before restarting and operating. Extensive vibration of mower during operation is an indication of damage. The unit should be promptly inspected and repaired.

Maintenance & Adjustment

General Recommendations

- Always observe safety rules when performing any maintenance.
- warranty on this lawn mower does not cover items that have been subjected to operator abuse or negligence. To receive full value from warranty, operator must maintain the lawn mower as instructed here.
- Changing of engine- governed speed will void engine warranty.
- All adjustments should be checked at least once each season.
- Periodically check all fasteners and make sure these are tight.

WARNING: Always stop engine, disconnect spark plug, and ground against engine before performing any type of maintenance on your machine.

Lubrication

1. Lubricate pivot points on the blade control at least once a season with light oil. This control must operate freely in both directions. See Fig. 6-1.



Figure 6-1

2. The transmission is pre-lubricated and sealed at the factory and does not require lubrication.
3. Follow the accompanying engine manual for lubrication schedule and instruction for engine lubrication.

Deck Care

Clean underside of the mower deck after each use to prevent build-up of grass clippings or other debris. Follow steps below for this job.

1. Disconnect spark plug wire. Drain gasoline from lawn mower or place a piece of plastic under the gas cap.
2. Tip mower so that it rests on the housing. Keep the side with the air cleaner facing up. Hold mower firmly.
WARNING: Never tip the mower more than 90° in any direction and do not leave the mower tipped for any length of time. Oil can drain into the upper part of the engine causing a starting problem.
3. Scrape and clean the underside of the deck with a suitable tool.
4. Put the mower back on its wheels on the ground. If you had put plastic under the gas cap earlier, make sure to remove it now.

Deck Wash (If Equipped)

Your mower's deck may be equipped with a water port on its surface as part of its deck wash system.

Use the deck wash to rinse grass clippings from the deck's underside and prevent the buildup of corrosive chemicals. Complete the following steps AFTER EACH MOWING:

1. Push the mower to a level, clear spot on your lawn, near enough for your garden hose to reach.
CAUTION: Make certain the mower's discharge chute is directed AWAY from your house, garage, parked cars, etc.
2. Thread the hose coupler (packaged with your mower's Operator's Manual) onto the end of your garden hose.

3. Attach the hose coupler to the water port on your deck's surface. See Fig. 6-2.

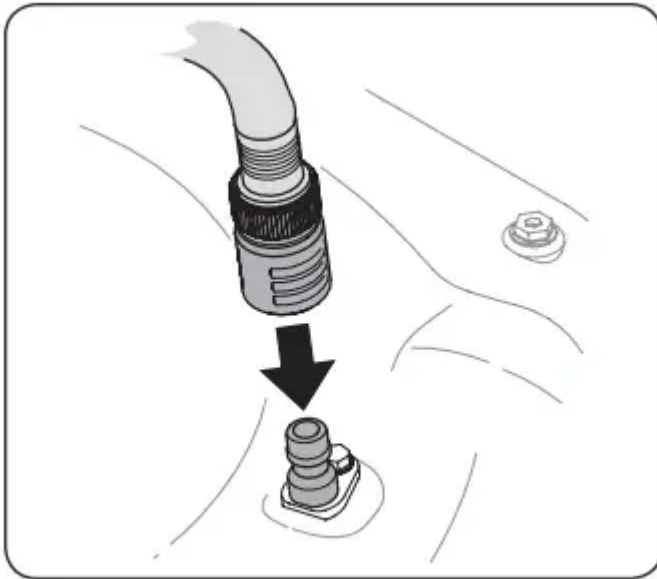

Figure 6-2

4. Turn the water on.
5. Start the engine as described in the Operation section.
6. Run the engine for a minimum of two minutes, allowing the underside of the cutting deck to thoroughly rinse.
7. Release blade control to stop the engine and blade.
8. Turn the water off and detach the hose coupler from the water port on your deck's surface.

After cleaning your deck, restart the mower. Keep the engine and blade running for a minimum of two minutes, allowing the underside of the cutting deck to thoroughly dry.

Engine Care

A list of key engine maintenance jobs required for good performance by the mower is given below. Follow the accompanying engine manual for a detailed list and instructions.

Maintain oil level as instructed in engine manual. Service air cleaner every 25 hours under normal conditions. Clean every few hours under extremely dusty conditions. Poor engine performance and flooding usually indicates that the air cleaner should be serviced. To service the air cleaner, refer to the engine manual. Clean spark plug and reset the gap once a season. Spark plug replacement is recommended at the start of each mowing season. Check engine manual for correct plug type and gap specifications. Clean engine regularly with a cloth or brush. Keep the top of the engine clean to permit proper air circulation. Remove all grass, dirt, and combustible debris from muffler area.

Service

Blade Care

WARNING: When removing the cutting blade for sharpening or replacement, protect your hands with a pair of heavy gloves or use a heavy rag to hold the blade.

Periodically inspect the blade adapter for cracks, especially if you strike a foreign object. Replace when necessary. Follow the steps below for blade service.

1. Disconnect spark plug boot from spark plug. Turn mower on its side making sure that the air filter and the carburetor are facing up.
2. Remove the bolt and the blade bell support which hold the blade and the blade adapter to the engine crankshaft. See Fig. 7-1.

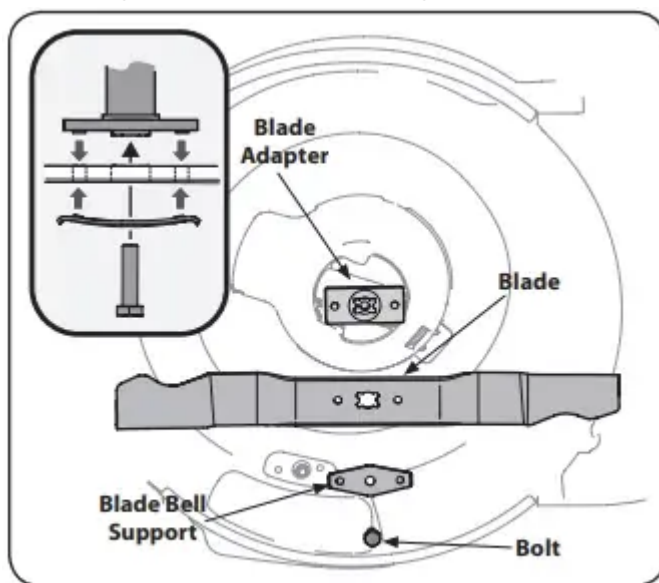

Figure 7-1

3. Remove blade and adapter from the crankshaft. See Fig. 7-1.
4. Remove blade from the adapter for testing balance. Balance the blade on a round shaft screwdriver to check. Remove metal from the heavy side until it balances evenly. When sharpening the blade, follow the original angle of grind. Grind each cutting edge equally to keep the blade balanced.
WARNING: An unbalanced blade will cause excessive vibration when rotating at high speeds. It may cause damage to mower and could break causing personal injury.
5. Lubricate the engine crankshaft and the inner surface of the blade adapter with light oil. Slide the blade adapter onto the engine crankshaft. Place the blade on the adapter such that the side of the blade marked "Bottom" (or with part number) faces the ground when the mower is in the operating position. Make sure that the blade is aligned and seated on the blade adapter flanges. See Fig. 7-1 inset.
6. Place blade bell support on the blade. Align notches on the blade bell support with small holes in blade.

7. Replace hex bolt and tighten hex bolt torque: 450 in. lbs. min, 600 in. lbs. max.

To ensure safe operation of your mower, periodically check the blade bolt for correct torque.

Belt Care

NOTE: Several components must be removed in order to change the mower's belt. See an authorized Service Dealer to have your belt replaced.

Replacing Battery (If Equipped)

WARNING: Batteries contain sulfuric acid which can cause burns. Do not short circuit or mutilate batteries in any way. Do not put batteries in fire as they can explode or release toxic materials.

1. Unhinge cover seal and lift off battery cover.
2. Remove positive and negative leads from battery, and pull up on battery to remove. See Fig. 7-2.

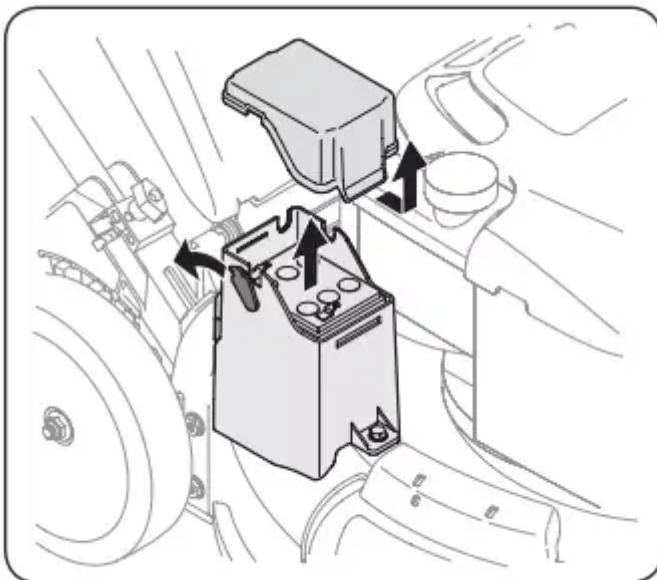

Figure 7-2

3. Replace with new battery. Connect the positive lead (red) to the positive side of the battery pack, then connect the negative lead (black) to the negative side. See Fig. 7-3.

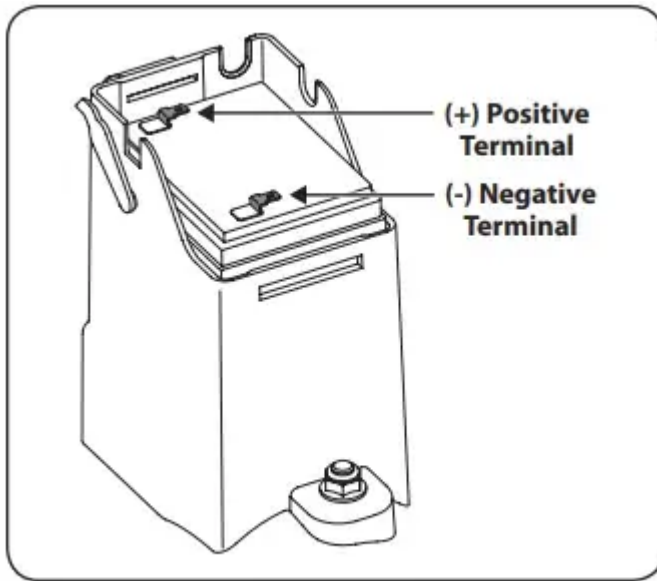

Figure 7-3

4. Reattach battery cover and cover seal.

Charging Battery (If Equipped)

WARNING: The battery contains corrosive fluid and toxic material; handle with care and keep away from children. Do not puncture, disassemble, mutilate or incinerate the battery. Explosive gases could be vented during charging or discharging. Use in a well ventilated area, away from sources of ignition.

NOTE: The special designed plug on the charger will only fit into the plug on the battery box.

1. Unhinge the cover seal and plug the battery charger into the port on the side of the battery housing. See Fig. 7-4.

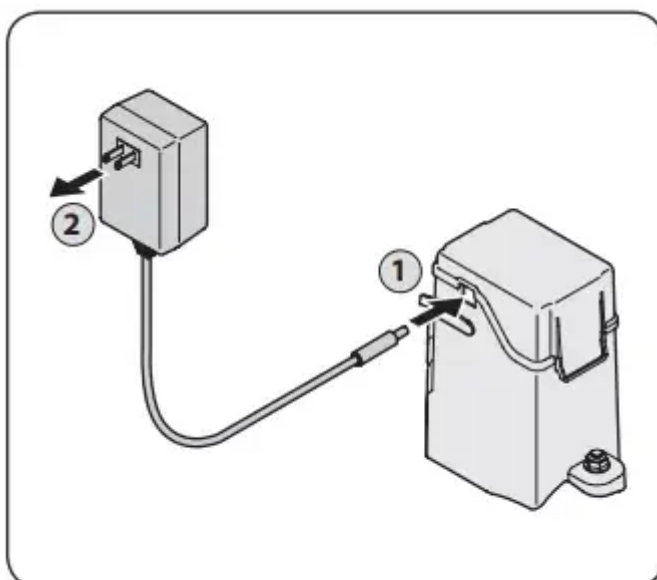

Figure 7-4

2. Insert the battery charger plug into a standard 120 volt household outlet. Charge battery for 8 to 10 hours before initial use. Do not charge longer than 12 hours. The battery should only need to be charged upon initial setup, at the end of the season, after any other extended periods of non-use, and as needed.

NOTE: If you frequently stop and restart the mower during each cut throughout the season (for instance when bagging), more frequent charging may be necessary.

3. After charging, disconnect charger plug from outlet first, then disconnect charger lead from battery and reattach cover seal.

IMPORTANT: Do not remove the battery pack from the electric starter housing for any reason other than replacement.

IMPORTANT: Always plug charger lead into battery pack lead first, and then insert battery charger plug into 120 volt standard household outlet. Follow this order of action every time you charge the battery.

Replacing Fuse (If Equipped)

The electric starter circuit and battery are protected by a 40 ampere fuse. If the fuse burns out, the electric starter will not operate. If the unit fails to start with the electric starter, perform the following steps to check the fuse inside the battery housing:

1. Open the battery cover as described in Replacing Battery.
2. Remove fuse from socket and inspect as shown in Fig. 7-5. If it is burned out, replace with standard automotive 40 ampere fuse.

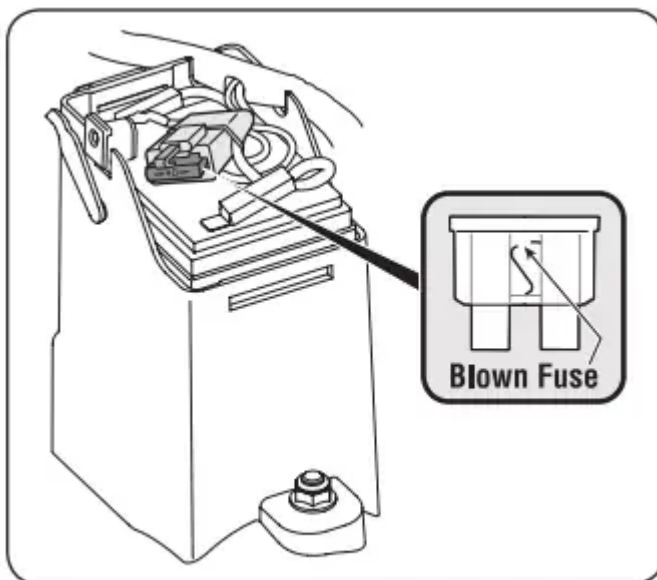

Figure 7-5

3. Carefully place wiring back into housing, and reattach battery cover.

NOTE: The engine can be started manually if the fuse burns out.

Off-Season Storage

The following steps should be taken to prepare your lawn mower for storage.

- Clean and lubricate mower thoroughly as described in the lubrication instructions.
- Coat mower's cutting blade with chassis grease to prevent rusting.
- Refer to engine manual for correct engine storage instructions.
- Secure side discharge chute to handle as shown in Fig. 7-6.

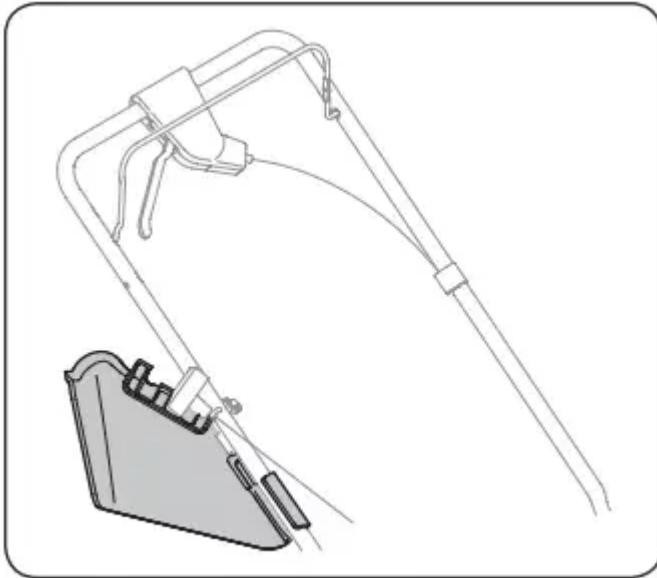

Figure 7-6

- Store mower in a dry, clean area. Do not store next to corrosive materials, such as fertilizer.

When storing any type of power equipment in a poorly ventilated or metal storage shed, care should be taken to rust-proof the equipment. Using a light oil or silicone, coat the equipment, especially cables and all moving parts of your lawn mower before storage.

Battery (If Equipped)

The battery must be stored with a full charge. Extended storage of a discharged battery will reduce life and capacity of the battery.

Troubleshooting



Problem	Cause	Remedy
Engine Fails to start	<ol style="list-style-type: none"> 1. Blade control disengaged. 2. Spark plug boot disconnected. 3. Fuel tank empty or stale fuel. 4. Engine not primed (if equipped with primer). 5. Faulty spark plug. 6. Blocked fuel line. 7. Engine flooded. 8. Fuel valve (if equipped) closed. 9. Engine not choked (if equipped with choke). 10. Burnt fuse. (Electric Start only) 	<ol style="list-style-type: none"> 1. Engage blade control. 2. Connect wire to spark boot. 3. Fill tank with clean, fresh gasoline. 4. Prime engine as instructed in the Operation section. 5. Clean, adjust gap, or replace. 6. Clean fuel line. 7. Wait a few minutes to restart, but do not prime. 8. Open fuel valve. See engine manual. 9. Choke engine. See engine manual. 10. Replace fuse (see Service Section).
Engine runs erratic	<ol style="list-style-type: none"> 1. Spark plug boot loose. 2. Blocked fuel line or stale fuel. 3. Vent in gas cap plugged. 4. Water or dirt in fuel system. 5. Dirty air cleaner. 6. Unit running with CHOKE (if equipped) applied. 	<ol style="list-style-type: none"> 1. Connect and tighten spark plug boot. 2. Clean fuel line; fill tank with clean, fresh gasoline. 3. Clear vent. 4. Drain fuel tank. Refill with fresh fuel. 5. Refer to engine manual. 6. Push CHOKE knob in.
Engine overheats	<ol style="list-style-type: none"> 1. Engine oil level low. 2. Air flow restricted. 	<ol style="list-style-type: none"> 1. Fill crankcase with proper oil. 2. Clean area around and on top of engine.
Occasional skips (hesitates) at high speed	<ol style="list-style-type: none"> 1. Spark plug gap too close. 	<ol style="list-style-type: none"> 1. Adjust gap to .030".
Idles poorly	<ol style="list-style-type: none"> 1. Spark plug fouled, faulty, or gap too wide. 2. Dirty air cleaner. 	<ol style="list-style-type: none"> 1. Reset gap to .030" or replace spark plug. 2. Refer to engine manual.

Excessive Vibration	<ol style="list-style-type: none"> 1. Cutting blade loose or unbalanced. 2. Bent cutting blade. 	<ol style="list-style-type: none"> 1. Tighten blade and adapter. Balance blade. 2. See an authorized service dealer.
Mower will not mulch grass	<ol style="list-style-type: none"> 1. Wet grass. 2. Excessively high grass. 3. Dull blade. 	<ol style="list-style-type: none"> 1. Do not mow when grass is wet; wait until later to cut. 2. Mow once at a high cutting height, then mow again at desired height or make a narrower cutting path. 3. Sharpen or replace blade.
Uneven cut	<ol style="list-style-type: none"> 1. Wheels not positioned correctly. 2. Dull blade. 	<ol style="list-style-type: none"> 1. Place front and rear wheels in same height position. 2. Sharpen or replace blade.
Mower will not self propel	<ol style="list-style-type: none"> 1. Belt not installed properly. 2. Debris clogging drive operation. 3. Damaged or worn belt. 	<ol style="list-style-type: none"> 1. Check belt for proper pulley installation and movement. 2. Stop engine, disconnect spark plug boot, and clean out debris. 3. Inspect and replace belt.



Replacement Parts



Component	Part Number and Description
Spark Plug (Honda)	490-250-0009 Spark Plug (NGK BPR6ES)
Spark Plug (Briggs & Stratton)	BS-799876 Spark Plug
Fuel Filter (Honda)	16952-ZA8-800 Fuel Filter
Fuel Filter (Briggs & Stratton)	BS-2980905+ Fuel Filter
Air Cleaner Element (Honda)	17211-ZL8-023 Air Cleaner Element
Air Filter Cartridge (Briggs & Stratton)	BS-491588S Air Filter Cartridge
Pre-Cleaner (Briggs & Stratton)	BS-4935375+ Pre-Cleaner
Fuel Tank Cap (Honda)	17620-Z0J-800 Fuel Tank Cap
Fuel Tank Cap (Briggs & Stratton Model)	BS-796577 Fuel Tank Cap
Fuel Tank Cap (Briggs & Stratton Model)	BS-799585 Fuel Tank Cap
Wheel (Front)	734-04579 Wheel (Front)
Wheel (Rear - Low)	734-04564 Wheel (Rear - Low)
Wheel (Rear - High)	634-04626 Wheel (Rear - High)
Discharge Chute	731-07131 Discharge Chute
Mulching Blade	942-0741A Mulching Blade
Xtreme Mulching Blade	942-04380 Xtreme Mulching Blade
Grass Bag	964-04117A Grass Bag
Belt	954-04260 Belt
Battery Charger	725-04329+ Battery Charger
Battery	725-04903+ Battery
Key	925-0201+ Key
Blade Removal Tool	490-850-0005 Blade Removal Tool
Oil Siphon	490-850-0008 Oil Siphon

+If Equipped

MANUFACTURER'S LIMITED WARRANTY FOR TROY-BILT

The limited warranty set forth below is given by Troy- Bilt LLC with respect to new merchandise purchased and used in the United States and/or its territories and possessions, and by MTD Products Limited with respect to new merchandise purchased and used in Canada and/or its territories and possessions (either entity respectively, "Troy- Bilt").

"Troy- Bilt" warrants this product (excluding its Normal Wear Parts and Attachments as described below) against defects in material and workmanship for a period of two (2) years commencing on the date of original purchase and will, at its option, repair or replace, free of charge, any part found to be defective in materials or workmanship. This limited warranty shall only apply if this product has been operated and maintained in accordance with the Operator's Manual furnished with the product, and has not been subject to misuse, abuse, commercial use, neglect, accident, improper maintenance, alteration, vandalism, theft, fire, water, or damage because of other peril or natural disaster. Damage resulting from the installation or use of any part, accessory or attachment not approved by Troy- Bilt for use with the product(s) covered by this manual will void your warranty as to any resulting damage.

Normal Wear Parts are warranted to be free from defects in material and workmanship for a period of thirty (30) days from the date of purchase. Normal wear parts include, but are not limited to items such as: batteries, belts, blades, blade adapters, tines, grass bags, wheels, rider deck wheels, seats, snow thrower skid shoes, friction wheels, shave plates, auger spiral rubber and tires.

Attachments — Troy- Bilt warrants attachments for this product against defects in material and workmanship for a period of one (1) year, commencing on the date of the attachment's original purchase or lease. Attachments include, but are not limited to items such as: grass collectors and mulch kits.

HOW TO OBTAIN SERVICE: Warranty service is available, WITH PROOF OF PURCHASE, through your local authorized service dealer. To locate the dealer in your area:

In the U.S.A.

Check your Yellow Pages, or contact Troy- Bilt LLC at P.O. Box 361131, Cleveland, Ohio 44136-0019, or call 1- 866- 840- 6483, 1- 330- 558- 7220 or log on to our Web site at www.troybilt.com.

In Canada

Contact MTD Products Limited, Kitchener, ON N2G 4J1, or call 1- 800- 668- 1238 or log on to our Web site at www.mtdcanada.com.

This limited warranty does not provide coverage in the following cases:

a. The engine or component parts thereof. These items may carry a separate manufacturer's warranty. Refer to applicable manufacturer's warranty for terms and conditions.

- b. Log splitter pumps, valves, and cylinders have a separate oneyear warranty.
- c. Routine maintenance items such as lubricants, filters, blade sharpening, tune-ups, brake adjustments, clutch adjustments, deck adjustments, and normal deterioration of the exterior finish due to use or exposure.
- d. Service completed by someone other than an authorized service dealer.
- e. Troy-Bilt does not extend any warranty for products sold or exported outside of the United States and/or Canada, and their respective possessions and territories, except those sold through Troy-Bilt's authorized channels of export distribution.
- f. Replacement parts that are not genuine Troy-Bilt parts.
- g. Transportation charges and service calls.
- h. Troy-Bilt does not warrant this product for commercial use.

No implied warranty, including any implied warranty of merchantability or fitness for a particular purpose, applies after the applicable period of express written warranty above as to the parts as identified. No other express warranty, whether written or oral, except as mentioned above, given by any person or entity, including a dealer or retailer, with respect to any product, shall bind Troy- Bilt. During the period of the warranty, the exclusive remedy is repair or replacement of the product as set forth above.

The provisions as set forth in this warranty provide the sole and exclusive remedy arising from the sale. Troy- Bilt shall not be liable for incidental or consequential loss or damage including, without limitation, expenses incurred for substitute or replacement lawn care services or for rental expenses to temporarily replace a warranted product.

Some states do not allow the exclusion or limitation of incidental or consequential damages, or limitations on how long an implied warranty lasts, so the above exclusions or limitations may not apply to you.

In no event shall recovery of any kind be greater than the amount of the purchase price of the product sold. Alteration of safety features of the product shall void this warranty. You assume the risk and liability for loss, damage, or injury to you and your property and/or to others and their property arising out of the misuse or inability to use the product.

This limited warranty shall not extend to anyone other than the original purchaser or to the person for whom it was purchased as a gift.

HOW STATE LAW RELATES TO THIS WARRANTY: This limited warranty gives you specific legal rights, and you may also have other rights which vary from state to state.

IMPORTANT: Owner must present Original Proof of Purchase to obtain warranty coverage.

Warning



This content is compiled from multiple sources and is provided for reference purposes only. It may not be complete or fully applicable to all situations. If you are unable to resolve your issue, please contact the product manufacturer or an authorized service provider for official support.

Document generated by [ManualsFile](#)

