

Model: CR-0375F Series 0.54L (1~3 Persons)

Important Safeguards

Read all instructions before use.

- Do not touch hot surfaces. Use handles or knobs.
- To protect against electrical shock, do not immerse cord, plugs, or the appliance in water or other liquid.
- Close supervision is necessary when the appliance is used by or near children.
- Unplug from outlet when not in use and before cleaning. Allow to cool before handling parts.
- Do not operate with a damaged cord or plug or if the appliance malfunctions or is damaged.
- Return appliance to an authorized service facility for examination, repair, or adjustment.
- The use of accessory attachments not recommended by the manufacturer may cause injuries.
- Do not use outdoors.
- Do not let cord hang over edge of table or counter, or touch hot surfaces.
- Do not place on or near a hot gas or electric burner, or in a heated oven.
- Extreme caution is needed when moving an appliance containing hot oil or other hot liquids.
- Always attach plug to appliance first, then plug cord into the wall outlet. To disconnect, turn control to "off", then remove plug.
- Do not use appliance for other than its intended use.
- Cook only in the removable container. Do not immerse the main body in water.

Note: This appliance has a polarized plug (one blade is wider). It will fit into a polarized outlet only one way. If the plug does not fit, reverse it. If it still does not fit, contact a qualified electrician. Do not attempt to defeat this safety feature.

Caution: During use, the internal parts of the rice cooker and the area around the steam vent are hot. Keep out of reach of children to avoid injury.

Specifications

Model: CR-0375F

Rated Voltage: AC 120V (AC Only), 60Hz

Rated Power: 425W (Approx.)

Safety Precautions

Read the product safety guide carefully. "Warning" and "Caution" indicate different levels of hazard.

Warnings - Do Not:

- Use pots not designed for this cooker, use an abnormal pot, or use without the inner pot. Risk of electric shock or fire.
- Clean the product with water or any liquid. Risk of electric shock or fire. If water contacts the product, unplug and contact service center.
- Alter, reassemble, disassemble, or repair the appliance. For repair, contact dealer or service center.
- Insert metal objects (pins, wires) or any substances into the steam exhaust outlet or any slot. Risk of electric shock or fire. Keep away from children.
- Put foreign substances into the Steam cap or the product. Risk of electric shock or fire.
- Allow persons (including children) with reduced physical, sensory, or mental capabilities, or lack of experience/knowledge to use the appliance without supervision. Do not let children play with the device.
- Repeatedly plug and unplug the power cord excessively. Risk of electric shock or fire.
- Use on a rice chest or shelf. Risk of fire, electric shock, or damage.
- Press the power cord between furniture. Risk of electric shock or fire.
- Use the product without the Detachable Cover attached. Risk of electric shock, fire, steam leak, or product disorder.

Cautions - Do Not:

- Use on an unstable surface, cushion, or prone to falling. Use on flat surfaces only.
- Use the inner pot for other purposes or heat it on a gas stove. This can deform the pot or damage the inner coating.
- Place on a rough or tilted top.
- Use near walls or furniture. Vapor or heat may cause damage, discoloration, or deformation.

- Use unsuitable scrubbers (e.g., green cotton, wire mesh) on the inner pot. Use only soft sponges or cloths to avoid damaging the coating.
- Use the cooker for unintended purposes.
- Continue use if strange smell or smoke occurs. Unplug and contact service.
- Use any voltage other than AC 120V.
- Touch the metallic surface of the inner pot or heating plate after cooking/warming. Risk of burns.
- Use the cooker near a strong magnetic field.
- Drop or impact the cooker.
- Fill the Inner Pot beyond its maximum capacity.
- Leave the Rice Shovel inside during the keep-warm function.

Name of Each Part & How to Clean and Maintain

NAME OF EACH PART



Accessories



Manual



Rice scoop



Measuring Cup



Power cord

Attaching the Steam Cap and Gasket:



Steam cap exploded view



1. As shown in the picture, fit the rubber gasket into the groove and insert it.



2. Insert the steam cap into the hole first and then combine it.

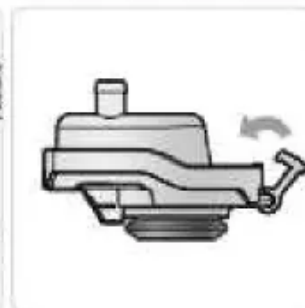

3. Fasten the steam cap clamp. *The detaching method is in the reverse order of attaching.

1. Fit the rubber gasket into the groove.
2. Insert the steam cap into the hole and combine it.

3. Fasten the steam cap clamp.
(Detaching is the reverse order.)

Cleaning:



- Clean the inner pot with a soft dishcloth. Do not use rough sponges.
- Wash the Inner Pot and Detachable Cover with neutral detergent and dry them.
- Wipe the main body, heating plate, and temperature sensor with a dry, clean cloth.
- Ensure all parts are completely dry before reassembly or storage.
- Clean the appliance after cooking foods with strong flavors to prevent odors.

How to Attach and Detach the Detachable Lid

As shown in the picture on the right, you can attach it by holding the handle mark with the thumb and index finger when attaching the steam cap, press the steam cap firmly into the lid like in the picture to the left. Broccoli steaming the lid, the steam cap has been attached to the lid.



As shown in the picture on the right, you can



NAME AND FUNCTION OF EACH PART/ ERROR CODE AND POSSIBLE CAUSE

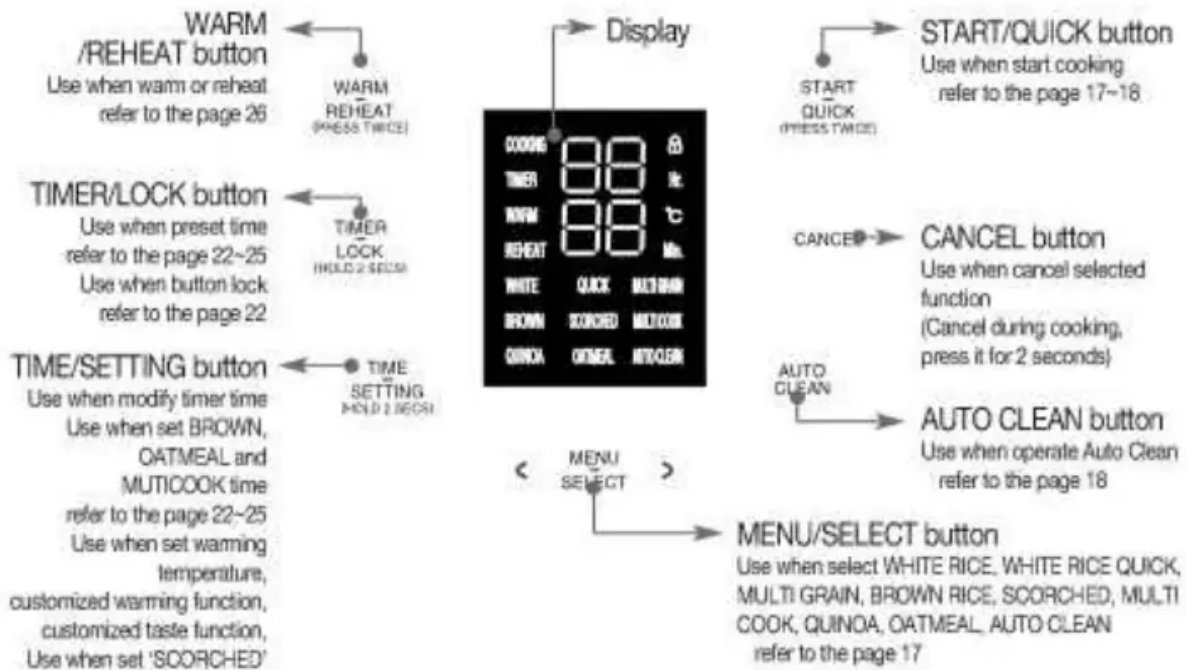

After plug the power cord and do nothing, display will show as above which indicate that the appliance is in 'Standby' mode.
 (Menus on 'Standby' mode display may differ as per customer setting)
 Press 'Cancel' button to enter 'Standby' mode.
 Press the button until you hear the buzzer sound. The image of display may different with actual display.

< Standby mode display >

Error Code and Possible Cause

Inner Pot is not inserted



Temperature sensor problem (" _ "will blink) (Consult the service center and dealer)



When the operation don't finish for a long time. (Consult the service center and dealer) refer to the page 29



This indicates that there is a problem with the internal memory of MICOM (Consult the service center and dealer)



This indicates that there is a problem with the external memory of MICOM. (Consult the service center and dealer)



This indicates that there is a problem with the environment sensor. (Consult the service center and dealer)

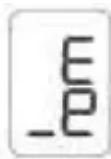

If the touch button is pressed for more than 8 seconds, an error is displayed



Preparations for Cooking

1. Clean the inner pot and remove any moisture.
2. Measure the rice correctly using the provided measuring cup.
Recommended: 1 full cup per person.
3. Rinse the rice in a separate container until the water becomes clear.
4. Put rinsed rice into the inner pot.
5. Add water according to the selected menu, using the water level lines inside the pot.
 - **WHITE, WHITE QUICK, SCORCHED, QUINOA:** Use the WHITE water level line. Max capacity: 3 persons for WHITE, 2 persons for others.

- **MULTI GRAIN/BROWN:** Use the "Mixed/Brown, GABA" water level line. Max capacity: 2.5 persons.

For hard grains like beans: presoak or boil first, then use Mixed Rice mode.

For stickier rice or old rice: add slightly more water.

For presoaked rice or softer rice: add slightly less water.

6. Place the inner pot into the main body, ensuring the bottom is clean and dry. Cover with the inner lid.

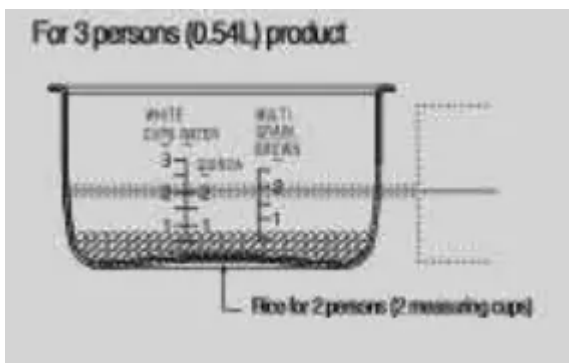

How to Cook

1. Press the "MENU/SELECT" button to cycle through cooking modes: WHITE RICE, WHITE RICE QUICK, MULTI GRAIN, BROWN RICE, SCORCHED, MULTI COOK, QUINOA, OATMEAL, AUTO CLEAN.



2. Select your desired mode.

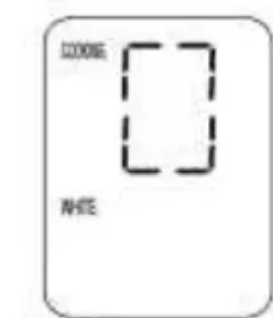

3. Press the "START/QUICK" button to begin cooking.

The display will show the remaining cooking time.



4. When cooking is complete, the appliance will switch to keep-warm mode.



Cooking Time by Menu

MENU	Capacity (Persons)	Approx. Cooking Time
WHITE RICE	0.5-3	31-37 Min
WHITE RICE QUICK	0.5-2	24-30 Min
MULTI GRAIN	0.5-2.5	56-61 Min
BROWN RICE	0.5-2.5	67-86 Min
SCORCHED RICE	0.5-2	46-56 Min
QUINOA	0.5-2	46-52 Min
OATMEAL	0.5-2	10-25 Min
MULTI COOK	Up to WHITE rice water level 1	~23 Min
AUTO CLEAN	-	~22 Min

How to Use "Scorched Rice"

1. Select "SCORCHED RICE" mode.



2. Press START/QUICK. This mode serves up to 2 persons.
3. Use the water amount for "WHITE rice." Do not wash the rice too thoroughly (water should be slightly opaque).
4. For best results, let rice and water sit in the closed pot for about 30 minutes before starting.
5. To make rice crisper, you can enable an extra crispiness function in the settings menu.

How to Customize Your Rice and Flavor

You can adjust the cooking texture/flavor for WHITE RICE, WHITE RICE QUICK, MULTI GRAIN, and BROWN RICE.

1. Enter the "Customized Cooking function" setting mode by pressing the TIME/SETTING button for 2 seconds, then pressing it twice more.
2. Use the MENU/SELECT button to choose a level (0,1,2,3). Level 0 is the default.
3. Press WARM/REHEAT or START/QUICK to save.

How to Use "Brown Rice" (Germination Function)

1. For germination, soak brown rice in water for 16 hours (do not exceed). Rinse before and after soaking.
2. Select "BROWN" mode. The display will show "O H." (0 hour germination) or you can set 3 hours.
3. Use the TIME/SETTING button to set germination time (0H or 3H).
4. Press START/QUICK to begin. The cooker will germinate (if time set) then cook automatically.

Precautions: Use brown rice within 1 year of harvest. Timer is not available with the 3H germination setting. Results vary by rice type.

How to Use "Multi Cook"

For steaming foods like dumplings, sweet potatoes, or potatoes.

1. Select "MULTI COOK" mode. Default time is 20 minutes.
2. Adjust time (10 min to 1.5 hours) using TIME/SETTING button.
3. Add 1/2 to 1 cup of water to the inner pot, place the steaming plate, add food, close lid.
4. Press START/QUICK.

You can also use the timer function with MULTI COOK.

How to Use "Oatmeal"

1. Select "OATMEAL" mode. Default time is 5 minutes.
2. Adjust cooking time (5 to 50 minutes) using TIME/SETTING button.
3. Add steel-cut oatmeal and water/milk to the inner pot (see recommended ratios in manual).
4. Press START/QUICK.

How to Use Timer Function

1. Select your desired menu (WHITE RICE, MULTI GRAIN, SCORCHED, QUINOA, AUTO CLEAN).
2. Press the TIMER/LOCK button.
3. Set the completion time using the TIME/SETTING button (1h to 12h 50min, in 10-min increments).
4. Press START/QUICK. The cooker will start automatically at the set time.

Precautions: Do not use dry or old rice with timer. Ensure correct water level. Do not set excessively long timer times.

Button Locking Function

To prevent accidental button presses:

- **To Lock:** In standby mode, press and hold the TIMER/LOCK button for 2+ seconds. "🔒" will flash.
- **To Unlock:** Press and hold TIMER/LOCK button for 2+ seconds again, or power off and on.

To Keep Cooked Rice Warm and Tasty

Adjusting Warm Temperature

1. In standby mode, press TIME/SETTING for 2+ seconds to enter Warm Temp setting.
2. Adjust temperature using MENU/SELECT button.
3. Default is 74°C.
 - If rice smells sour or is too soft: increase temperature 1-2°C.
 - If rice is yellowish or dry: decrease temperature 1-2°C.

Customized Warm Function

Adjust if excess water appears when opening lid or if rice at edges is overcooked.

1. Enter Warm Temperature setting, then press TIME/SETTING once more for Customized Warm.
2. Adjust level with MENU/SELECT button.

Preventing Unpleasant Smells

- Keep the appliance and lid clean.
- Do not keep rice warm for more than 12 hours.
- For deep cleaning, add water (for 2 servings) and 1 tbsp vinegar to the pot, run AUTO CLEAN mode, then rinse thoroughly.

Troubleshooting

Before contacting service, check these common issues:

Symptom	Possible Solution
Rice not cooked	Ensure START/QUICK was pressed. Check for power outage.
Rice half-cooked/layered	Check water measurement, rinsing, and rice condition. Add a little more water.
Water overflows	Do not exceed maximum water level. Use correct menu.
Unpleasant smell during warming	Ensure lid is closed. Do not warm over 12 hours. Clean appliance thoroughly.
"E..." code displayed	Unplug and contact service center.
Rice too scorched	Ensure no debris on inner pot bottom or temperature sensor. Check Customized Cooking settings.
Lid cannot be closed	Ensure inner lid is properly attached.
Steam leaks from lid	Clean the rubber gasket/packing.

Warning

This content is compiled from multiple sources and is provided for reference purposes only. It may not be complete or fully applicable to all situations. If you are unable to resolve your issue, please contact the product manufacturer or an authorized service provider for official support.

Document generated by [ManualsFile](#)

