

Shark® Rocket® Corded Ultra-Light Vacuum

HV300 • CS100 • CS110 Series

OWNER'S GUIDE

IMPORTANT SAFETY INSTRUCTIONS

To reduce the risk of fire, electric shock, injury, or property damage, when using an electrical appliance, basic precautions should always be followed, including the following:

READ ALL INSTRUCTIONS BEFORE USING THIS VACUUM

1. Inspect power cord and plug for any damage before use. DO NOT use vacuum cleaner with a damaged cord or plug. Turn off all controls before plugging in or unplugging the vacuum cleaner. Store your vacuum cleaner with the power cord secured around the two cord hooks. To minimize the risk of power cord damage, do not allow the motorized brush roll to ingest the cord. If this occurs, immediately shut off power to the vacuum and remove the cord.
2. This appliance has a polarized plug, if the plug does not fit fully into the outlet, reverse the plug (one blade is wider than the other). If it still does not fit, contact a qualified electrician. DO NOT force into outlet or try to modify to fit.
3. Your vacuum cleaner may consist of a motorized nozzle, wand, hose, and/or vacuum pod. This device contains electrical connections, electrical wiring, and moving parts that potentially present risk to the user.
4. Use only identical replacement parts.
5. Carefully observe and follow the instructions provided below to avoid improper use of the appliance. DO NOT use the vacuum for any purpose other than those described in this manual.
6. Before use, carefully inspect all parts for any damage. DO NOT use if any parts are damaged.
7. The use of an extension cord is NOT recommended.
8. This vacuum cleaner contains no serviceable parts.
9. This appliance can be used by persons with reduced physical, sensory or mental capabilities or lack of experience and knowledge if they have been given supervision or instruction concerning use of the appliance in a safe way and understand the hazards involved. Cleaning and user maintenance shall not be made by children. Keep the appliance and its cord out of reach of children. DO NOT allow the appliance to be used by children. DO NOT allow to be used as a toy. Close supervision is necessary when used near children.

10. Always turn off the vacuum cleaner before connecting or disconnecting any motorized nozzles or other accessories.
11. DO NOT handle plug or vacuum cleaner with wet hands.
12. DO NOT use without filters in place.
13. Only use Shark® branded filters and accessories.
14. DO NOT damage the power cord:
 - a) DO NOT pull or carry vacuum cleaner by the cord or use the cord as a handle.
 - b) DO NOT unplug by pulling on cord. Grasp the plug, not the cord.
 - c) DO NOT run the vacuum cleaner over the power cord, close a door on the cord, pull the cord around sharp corners, or leave the cord near heated surfaces.
15. DO NOT put any objects into nozzle or accessory openings. DO NOT use with any opening blocked; keep free of dust, lint, hair, and anything that may reduce airflow.
16. DO NOT use if nozzle or accessory airflow is restricted. If the air paths or the motorized floor nozzle become blocked, turn the vacuum cleaner off and unplug from electrical outlet. Remove all obstructions before you plug in and turn on the unit again.
17. Keep nozzle and all vacuum openings away from hair, face, fingers, uncovered feet, or loose clothing.
18. DO NOT use if vacuum cleaner is not working as it should, or has been dropped, damaged, left outdoors, or dropped into water.
19. Use extra care when cleaning on stairs.
20. DO NOT leave the vacuum cleaner unattended while plugged in.
21. When powered on, keep the vacuum cleaner moving over the carpet surface at all times to avoid damaging the carpet fibers.
22. DO NOT place vacuum cleaner on unstable surfaces such as chairs or tables.
23. Your Shark® vacuum may not be designed to stand up on its own. When taking a break from cleaning, you may need to lean it against furniture or a wall, or lay it flat on the floor. Using the vacuum for an application where the unit lacks stability may result in personal injury.
24. DO NOT use to pick up:
 - a) Liquids
 - b) Large objects
 - c) Hard or sharp objects (glass, nails, screws, or coins)

- d) Large quantities of dust (drywall dust, fireplace ash, or embers). DO NOT use as an attachment to power tools for dust collection.
- e) Smoking or burning objects (hot coals, cigarette butts, or matches)
- f) Flammable or combustible materials (lighter fluid, gasoline, or kerosene)
- g) Toxic materials (chlorine bleach, ammonia, or drain cleaner)

25. DO NOT use in the following areas:

- a) Poorly lit areas
- b) Wet or damp surfaces
- c) Outdoor areas
- d) Spaces that are enclosed and may contain explosive or toxic fumes or vapors (lighter fluid, gasoline, kerosene, paint, paint thinners, mothproofing substances, or flammable dust)

26. Turn off all controls before plugging in or unplugging the vacuum.

27. Unplug from electrical outlet when not in use and before any maintenance or cleaning.

28. Hand wash with water only. Washing with cleaning chemicals could damage the unit.

29. During cleaning or routine maintenance, DO NOT cut anything other than hair, fibers, or string wrapped around the brush.

30. Allow all filters to air-dry completely before replacing in the vacuum to prevent liquid from being drawn into electric parts.

31. Make sure the dust cup and all filters are in place after routine maintenance.

32. If provided, secure the power cord around the two cord hooks during storage.

SAVE THESE INSTRUCTIONS

ASSEMBLY

1. Insert Wand into Floor Nozzle. Ensure all connections click securely into place.
2. Insert Handheld Vacuum into the Wand.

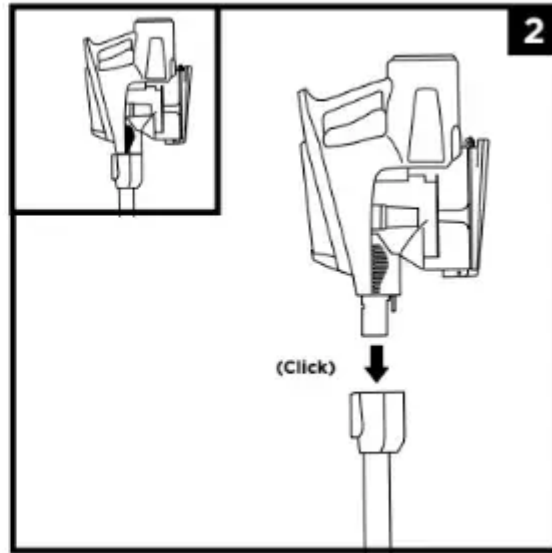
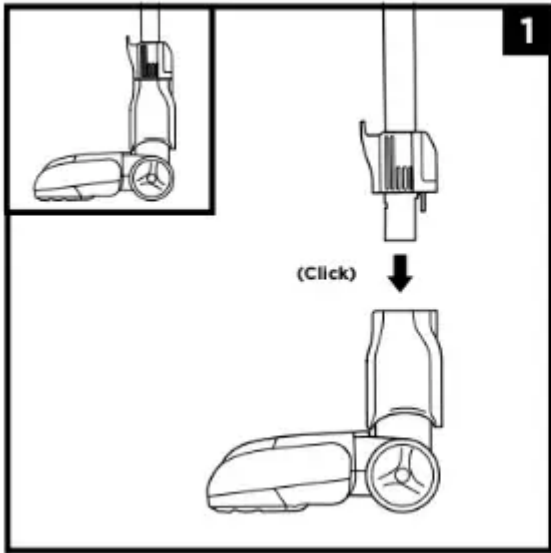

SETTINGS

Slide switch to the bottom to turn off power. To begin vacuuming, slide switch to the appropriate setting.

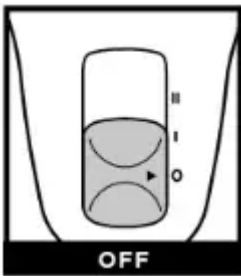

Bare Floor/Small Area Rugs :The brushrolls spin slowly to clean bare floors and small area rugs.

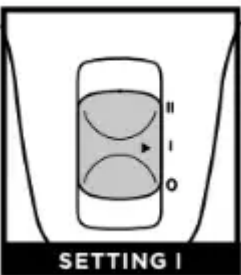

Carpet: The brushrolls spin faster to pick up debris below the surface of your carpets.



NOTE: For deep cleaning per ASTM F 608 (embedded dirt in carpets) please use setting II, Carpet.

NOTE: Select Carpet for stuck-on dust and debris.

CLEANING MODES

UPRIGHT

To clean floors, step on floor nozzle and tilt handheld vacuum back.



ABOVE-FLOOR WITH WAND

Detach the wand for more reach to clean baseboards, ceiling fans, window sills, and other hard-to-access areas. Stand the vacuum upright, then step on the foot pedal on the left side of the floor nozzle and pull the wand up to disconnect it.



ABOVE-FLOOR HANDHELD

Press the Wand Release button to lift the handheld vacuum off the wand. Great for cleaning stairs and furniture.



NOTE: All accessories are compatible with both the wand and the handheld vacuum.

STORAGE AND ACCESSORIES

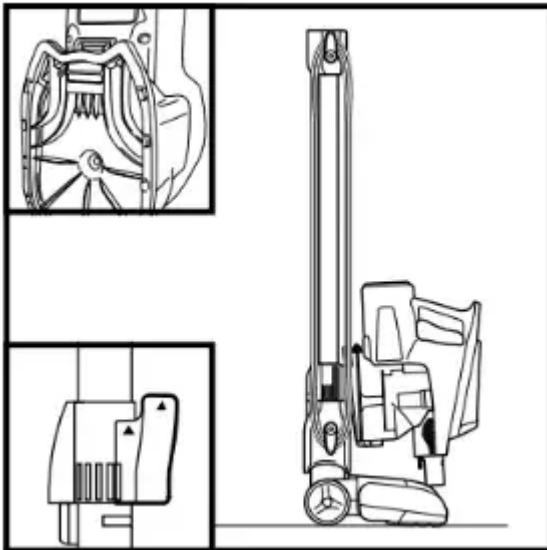

Press the wand release button on the top of the wand to detach the handheld vacuum. Align the catch on the bottom of the handheld vacuum with the storage hook on the wand. Slide the handheld vacuum down so the catch hangs from the storage hook. Wrap the cord around the two cord hooks starting with the top hook, leaving a little bit of slack while wrapping.

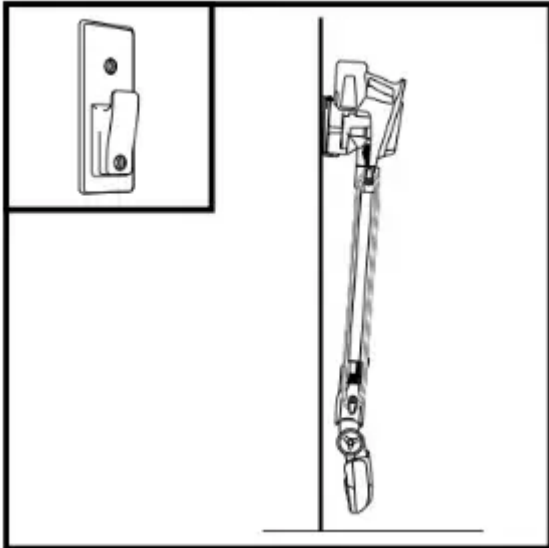

For convenient storage above the floor, a wall mount is available for purchase on sharkclean.ca/page/parts-and-accessories. It comes with hardware and an instruction sheet with a mounting template.

NOTE: Wrap the power cord around the top hook first, leaving a little slack while wrapping.

NOTE: Not all accessories come with all units. For a list of the accessories included with this model, see the top inside flap of the box. To order additional accessories, visit sharkclean.ca/page/parts-and-accessories.

Crevice Tool

Clean in tight spaces or reach baseboards and ceilings with this slim crevice tool. Various lengths available depending on the vacuum model.



Wide Upholstery Tool

The wide cleaning path helps remove pet hair, dust, and large debris from mattresses, couches, curtains, lampshades, and other delicate upholstered surfaces.



Dusting Brush



This brush dusts and cleans delicate surfaces. Great for use on fans, blinds, lampshades, and keyboards.

Dust-Away Hard Floor Attachment with Microfiber Pad

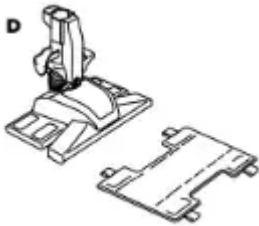

With direct suction powerful enough to handle big debris, this hard floor attachment is also gentle enough to easily wipe away fine dust on hardwood and tile floors. Includes a washable, reusable microfiber pad.

Hard Floor Hero™

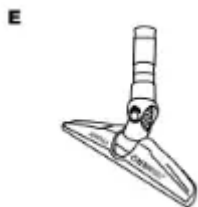

Designed to provide outstanding hard floor cleaning, this powerful tool is small enough to get into hard-to-reach areas while removing surface particles, dirt, stuck-on dust, and debris.

Under-Applique Wand



Clean under and behind hard-to-move appliances and furniture with this adjustable 36" tool. Flip the extension piece over to clean the underside of appliances.

Wall Mount



Install the mount to hang your vacuum on the wall for convenient storage. Includes screws, anchors, and instruction sheet with mounting template for easy installation.

Onboard Storage Clip



Removable clip attaches to the vacuum wand. Can hold up to two accessories at a time while cleaning or for storage.

Anti-Allergen Dust Brush



This brush features nylon fiber bristles specifically designed for removing fine dust and allergen particles from the most delicate surfaces.

MAINTENANCE

IMPORTANT: Unplug the vacuum before performing any maintenance.

EMPTYING THE DUST CUP

Empty the dust cup each time you vacuum and periodically during cleaning, when debris in the dust cup reaches the MAX fill line.

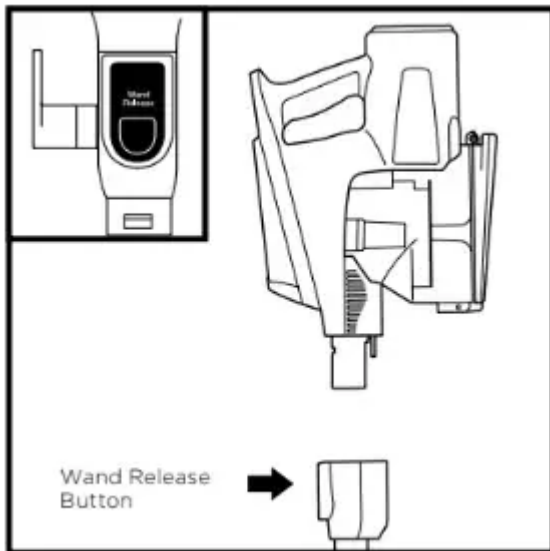

Press the wand release button and lift the handheld vacuum off the wand.

Press the Empty button on the front of the dust cup.

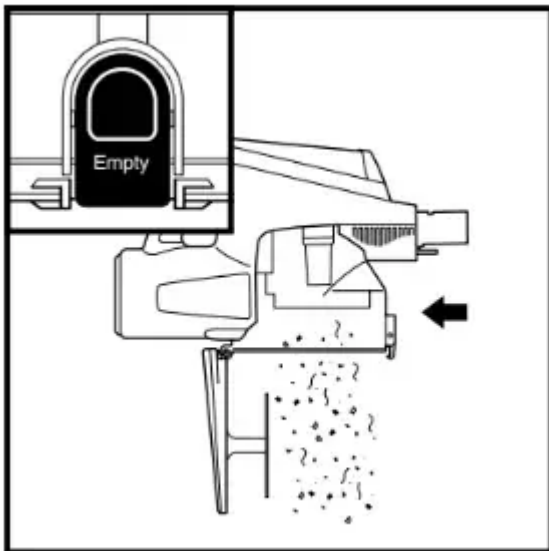

CLEANING FILTERS

Perform regular maintenance on your filters to keep your vacuum's suction power optimal.

IMPORTANT: To prevent damage, rinse filters with water **ONLY**. **DO NOT** use soap. Allow filters to air-dry for at least 24 hours before reinstalling them to prevent liquid from being drawn into electric parts.

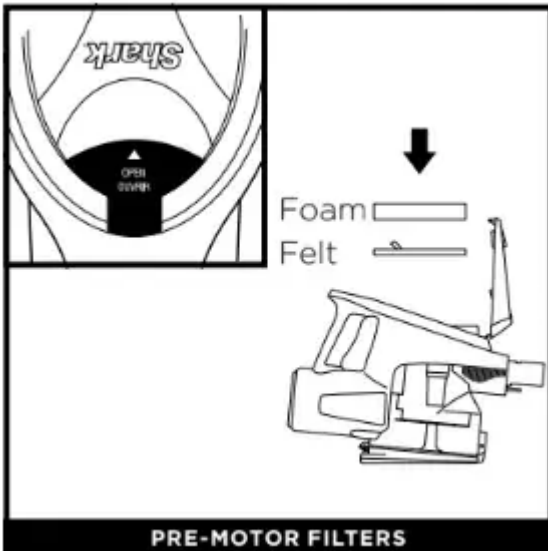

The Pre-Motor Filters should be washed once a month.

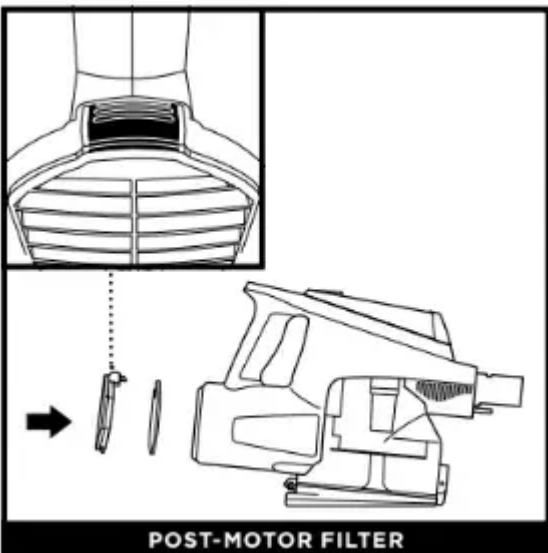

The Post-Motor Filter should be washed once every 9 months.

REPLACEMENT FILTERS

Replacement Pre-Motor Filter Kit (Foam & Felt) XFFV300 Clean once a month.

Replacement Post-Motor Filter XFFV300 Clean once a year.

NOTE: The pre-motor filters should be replaced every 2.5 years. The post-motor filter should be replaced every 3 years.

CHECKING FOR BLOCKAGES

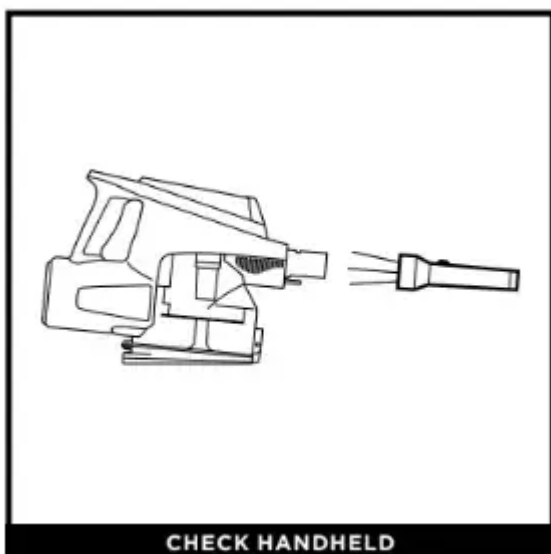

Remove the wand from the handheld vacuum and check all dust cup intake openings.

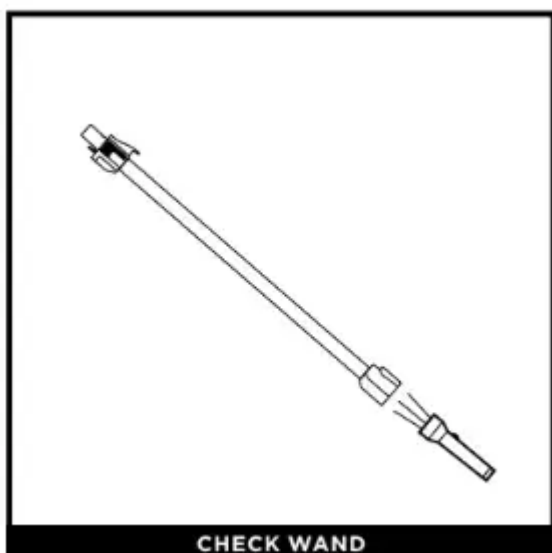

Detach the wand and check it for blockages.

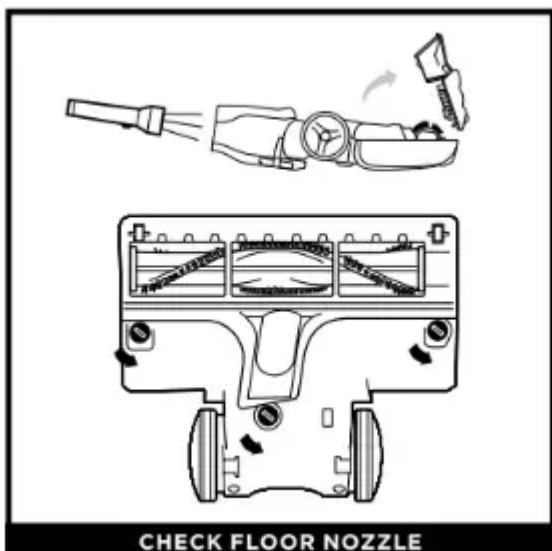

Detach the wand, then use the edge of a coin to open the three locks on the bottom of the floor nozzle. Remove the cover, then tilt back the neck of the floor nozzle and check the opening for blockages. Replace cover, pressing down firmly on all sides before turning locks clockwise to close.

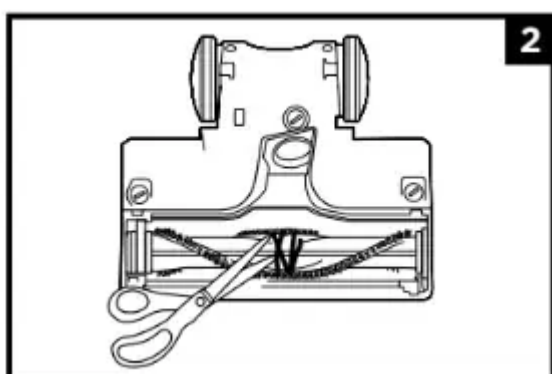
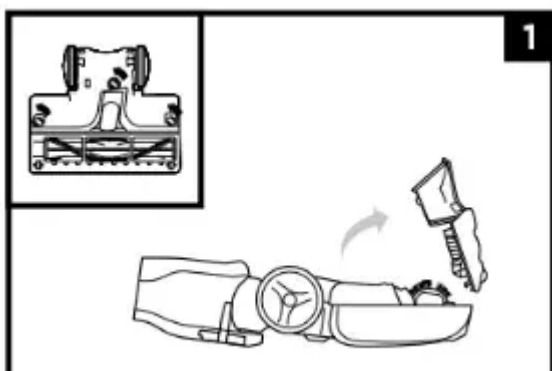

CLEANING THE BRUSHROLLS

1. Use the edge of a coin to open the three locks on the bottom of the floor nozzle.
2. Run scissors along the groove in the brushroll to cut or clear away any string, carpet fibers, hair, or other debris.

3. To reinstall the cover, line it up, then rotate down until it clicks into place. Use the edge of a coin to close the three locks on the bottom of the nozzle.

TROUBLESHOOTING

Vacuum is not picking up debris. No suction or low suction. (Refer to Maintenance section for more information.)

- Check filters to see if they need cleaning. Follow instructions for rinsing and completely air-drying the filters before reinstalling them.
- Dust cup may be full; empty dust cup.
- Check floor nozzle for blockages; clear blockages if required.
- Remove any string, carpet fibers, or hair that may be wrapped around the brushroll.
- Make sure the floor nozzle cover is locked in place. Press down firmly on all sides of the cover until it clicks into place, then turn the locks clockwise to close.

Vacuum lifts area rugs.

- Suction is powerful. Take care when vacuuming area rugs or rugs with delicately sewn edges.
- Turn off the unit to disengage the brushroll. To restart, slide the power switch to setting I, Bare Floor/ Small Area Rugs.

Brushroll does not spin.

- If Brushroll Indicator Light on the floor nozzle turns red, the brushroll has stopped spinning. Immediately turn off and unplug vacuum and remove blockage. Plug back into electrical outlet and turn vacuum on.
- If Brushroll Indicator Light on the floor nozzle is green, the blockage has been successfully cleared. If the light is still red, please contact Customer Service at 1 800 798-7398.

Vacuum turns off on its own or the indicator light flashes red.

If your vacuum overheats, the thermostat will automatically turn off the motor. Perform the following steps to restart:

1. Turn vacuum off and unplug it.
2. Empty dust cup and clean filters (see Maintenance section).
3. Check for blockages in the nozzle, wand, handheld vacuum inlet openings, and accessories.

4. Allow unit to cool for a minimum of 60 minutes.
 5. Plug in vacuum and turn it on.
-

SharkNinja FIVE (5) YEAR LIMITED WARRANTY

The Five (5) Year Limited Warranty applies to purchases made from authorized retailers of SharkNinja Operating LLC. Warranty coverage applies to the original owner and to the original product only and is not transferable.

SharkNinja warrants that the unit shall be free from defects in material and workmanship for a period of five (5) years from the date of purchase when it is used under normal household conditions and maintained according to the requirements outlined in the Owner's Guide, subject to the following conditions and exclusions:

What is covered by this warranty?

- The original unit and/or non-wearable parts deemed defective, in SharkNinja's sole discretion, will be repaired or replaced up to five (5) years from the original purchase date. In the event a replacement unit is issued, the warranty coverage ends six (6) months following the receipt date of the replacement unit or the remainder of the existing warranty, whichever is later. SharkNinja reserves the right to replace the unit with one of equal or greater value.

What is not covered by this warranty?

1. Normal wear and tear of wearable parts (such as foam filters, HEPA filters, pads, etc.), which require regular maintenance and/or replacement to ensure the proper functioning of your unit, are not covered by this warranty. Replacement parts are available for purchase at <https://www.sharkclean.com/parts-and-accessories/model-number/>.
2. Any unit that has been tampered with or used for commercial purposes.
3. Damage caused by misuse (e.g., vacuuming up water or other liquids), abuse, negligent handling, failure to perform required maintenance (e.g., not cleaning the filters, not removing debris from the brushroll), or damage due to mishandling in transit.
4. Consequential and incidental damages.
5. Defects caused by repair persons not authorized by SharkNinja. These defects include damages caused in the process of shipping, altering, or repairing the SharkNinja product (or any of its parts) when the repair is performed by a repair person not authorized by SharkNinja.
6. Products purchased, used, or operated outside North America.

How to get service

If your appliance fails to operate properly while in use under normal household conditions within the warranty period, visit <https://support.sharkclean.ca/hc/en-us> for product care and maintenance self-help. Our Customer Service Specialists are also available at 1 855 520-7816 to assist with product support and warranty service options, including the possibility of upgrading to our VIP warranty service options for select product categories. So we may better assist you, please register your product online at <https://www.sharkclean.ca/register/guarantee> and have the product on hand when you call.

SharkNinja will cover the cost for the customer to send in the unit to us for repair or replacement. A fee of \$25.95 (subject to change) will be charged when SharkNinja ships the repaired or replacement unit.

How to initiate a warranty claim

You must call 1 855 520-7816 to initiate a warranty claim. You will need the receipt as proof of purchase. We also ask that you register your product online at registeryourshark.com and have the product on hand when you call, so we may better assist you. A Customer Service Specialist will provide you with return and packing instruction information.

How state law applies

This warranty gives you specific legal rights, and you also may have other rights that vary from state to state. Some states do not permit the exclusion or limitation of incidental or consequential damages, so the above may not apply to you.

PRODUCT REGISTRATION

Benefits of registering your product and creating an account:

- Get easier, faster product support and access to warranty information
- Access troubleshooting and product care instructions
- Be among the first to know about exclusive product promotions

TIP: The model number is on the rating label behind the dust cup.

TIP: The date code is on one of the prongs of the power cord plug.

REGISTER YOUR PURCHASE

sharkclean.ca/register/guarantee

Scan QR code using mobile device

RECORD THIS INFORMATION

Model Number:

Date Code:

Date of Purchase: (Keep receipt)

Store of Purchase:

TECHNICAL SPECIFICATIONS

Voltage: 120V, 60Hz

Watts: 500W

© 2024 SharkNinja Operating LLC.

ROCKET and SHARK are registered trademarks of SharkNinja Operating LLC. DUST-AWAY and HARD FLOOR HERO are trademarks of SharkNinja Operating LLC.

US: Needham, MA 02494

CAN: Ville St-Laurent, QC H4S 1A7

1 800 798-7398

sharkclean.ca

Warning

This content is compiled from multiple sources and is provided for reference purposes only. It may not be complete or fully applicable to all situations. If you are unable to resolve your issue, please contact the product manufacturer or an authorized service provider for official support.

Document generated by [ManualsFile](#)