

# COMMERCIAL FREEZER/REFRIGERATOR

A01063601 (August2014)

## Product Registration

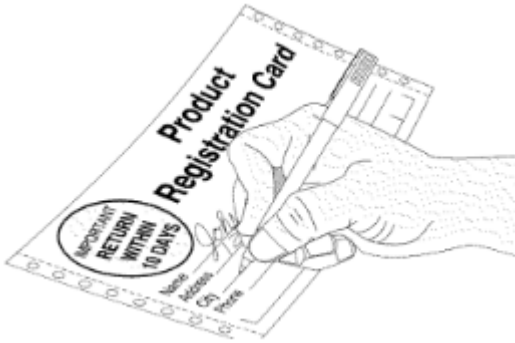

### Read and Save These Instructions

These instructions include information which is intended to assure the operator of correct installation, operation and service. Before attempting installation, adjustment or maintenance, be certain of the following:

That you have read and fully understand the instructions. That you have all the tools required and are trained to use them. That you have met all installation and usage restrictions and are familiar with the functions and operations of the unit. That you follow all instructions exactly as given.

All the fittings, measurements, recommendations and procedures are significant. Substitutions and approximations must be avoided. Improper handling, maintenance, installation and adjustment, or service attempted by anyone other than a qualified technician, may void the future warranty claims and cause damage to the unit and/or result in injury to the operator and/ or bystanders.

### Record your Model and Serial Numbers

Record the model number and serial number of this appliance in the space provided below (the serial plate is located inside the cabinet compartment).

Model Number: Serial Number: Purchase Date: Register Your Product

Register Your ProductThe self- addressed PRODUCT REGISTRATION CARD (shown above) should be filled in completely, signed and returned to the address provided.

## Important Safety Instructions

Read all instructions before using this appliance.

### WARNING

#### For Your Safety

Do not store or use gasoline or other flammable vapors and liquids in the vicinity of this unit or any other appliance. Read product labels for flammability and other warnings.

## **WARNING**

### **Child Safety**

Child Safety- Destroy carton, plastic bags, and any exterior wrapping material immediately after the appliance is unpacked. Children should never use these items for play. Cartons covered with rugs, bedspreads, plastic sheets or stretch wrap may become airtight chambers and can quickly cause suffocation.- Remove all staples from the carton. Staples can cause severe cuts, and destroy finishes if they come in contact with other appliances or furniture.- An empty, discarded ice box, refrigerator, or freezer is a very dangerous attraction to children.- Remove and discard any spacers used to secure the shelves during shipping. Small objects are a choke hazard to children.

### **Proper Disposal of Appliance**

## **WARNING**

### **Risk of Child Entrapment**

Child entrapment and suffocation are not problems of the past. Junked or abandoned refrigerators or freezers are still dangerous - even if they will sit for "just a few days". If you are getting rid of your old refrigerator or freezer, please follow the instructions below to help prevent accidents:

Remove the door. Leave shelves in place so children may not easily climb inside.

## **Important Safety Instructions (continued)**

### **Electrical Information**

## **WARNING**

These guidelines must be followed to ensure that safety mechanisms in the design of this appliance will operate properly.

## **WARNING**

Avoid fire hazard or electric shock. Do not use an extension cord or an adapter plug. Do not remove any prong from the power cord.

### Grounding type wall receptacle

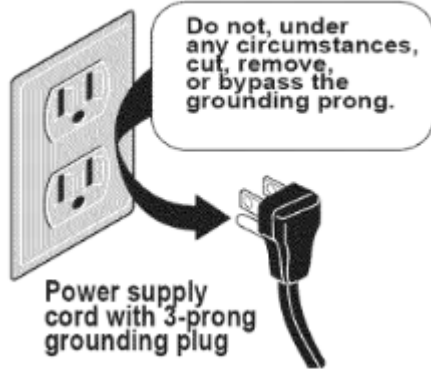

Refer to the serial plate for correct electrical rating. The power cord of the appliance is equipped with a three- prong grounding plug for protection against shock hazards. It must be plugged directly into its own properly grounded three- prong receptacle, protected with a 15- amp time delay fuse or circuit breaker. The receptacle must be installed in accordance with the local codes and ordinances. Consult a qualified electrician. Receptacles with Ground Fault Circuit Interrupters (GFCI) are NOT RECOMMENDED. DO NOT USE AN EXTENSION CORD OR AN ADAPTER PLUG.

If the voltage varies by 10% or more, appliance performance may be affected. Operating the appliance with insufficient power can damage the compressor. Such damage is not covered under the warranty. If you suspect your voltage is high or low, consult your power company for testing.

To prevent the appliance from being turned off accidentally, do not plug the unit into an outlet controlled by a wall switch or pull cord. DO NOT pinch, knot, or bend the power cord in any manner.

### Other Precautions

#### WARNING

NEVER unplug the appliance by pulling on the power cord. Always grip the plug firmly and pull straight out from the receptacle. To avoid electrical shock, unplug the appliance before cleaning.

#### NOTE

Turning the control to "OFF" turns off the compressor but does not disconnect power to other electrical components.

## First Steps

### Inspection for Damage

Inspect the underside of the cabinet and packaging for damage, similar to what can be caused with a forklift. If hidden damage is found after uncreating, immediately call the delivery carrier and request an inspection. Retain all packaging and crating materials until the inspection is complete.

### Parts and Accessories

Check to make sure that you have received the box containing all of the components listed below.

A Carriage Bolt (4)

B Lock Nut (4)

C Swivel Casters (2)

D Fixed Caster (2)

E Hex Screw (10)

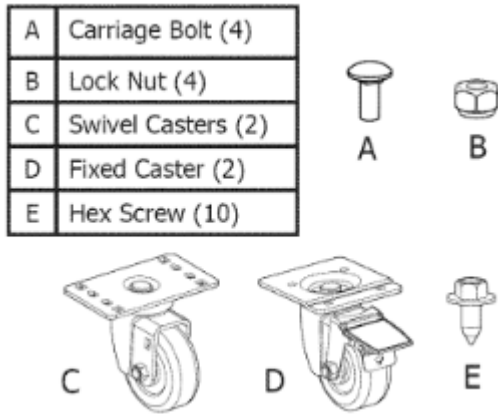

1. Remove carton and all loose parts from inside the unit.

### Tools Needed

The following tools are required to assemble and install the casters to the unit:

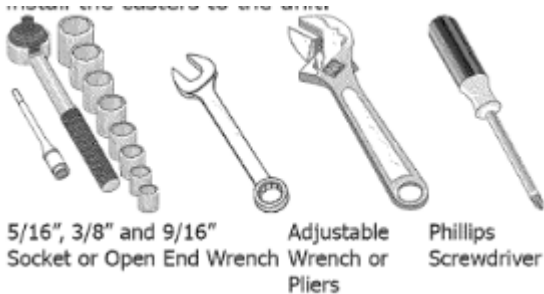

5/16" 3/8" and 9/16 Adjustable Phillips Socket or Open End Wrench Wrench or Screwdriver Pliers

### Uncrating and Set-up

1. Remove carton and all loose parts from inside the unit.

2. Remove the rear access guard and place it and the screws in a safe place for reassembly later.

3. Using an assistant, carefully tip the unit onto its back and rest on blocks to avoid damaging the condensate drain hose and the plastic raceway that covers the evaporator tubing on the back of the cabinet.

4. Remove and discard the 2 front brackets with leg leveler using a 5/16" socket wrench. See Figure 1.

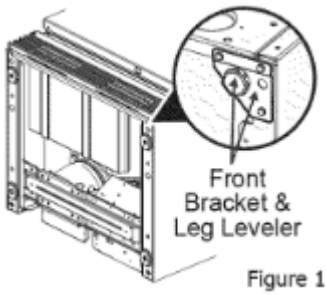

Figure 1

**Figure 1**

5. FOR GLASS DOOR MODELS ONLY - Remove bottom door support bracket and screw opposite the door hinge using a 3/8" socket wrench.

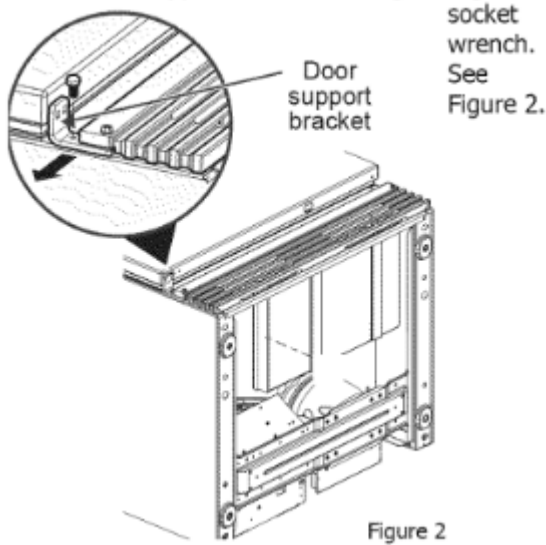

Figure 2

**Figure 2**

**Front Fixed Caster Installation**

Locate and align fixed caster (with brake lever facing front of unit - see Figure 3) over the same mounting holes from bracket in Figure 1 using 6 hex screws (3 for each caster). Secure the screws snug using a 3/8" open end wrench. Repeat this procedure for opposite corner. DO NOT OVERTIGHTEN.

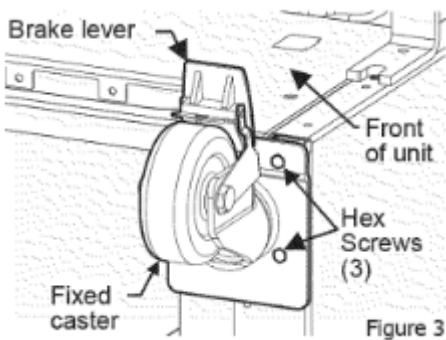

Figure 3

**Figure 3**



## Rear Swivel Caster Installation

1. Remove and discard the screws shown in Figure 4 from each bottom corner using a 5/16" socket wrench.

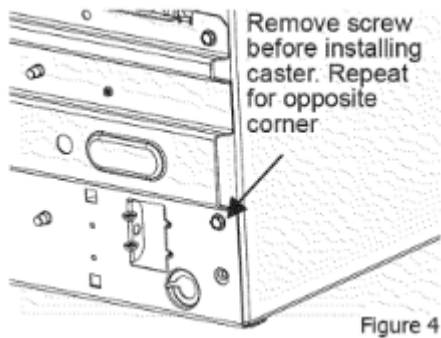

**Figure 4**

2. Locate and align swivel caster over the holes and install with 2 hex screws. Secure the screws snug using a 3/8" socket wrench. **DO NOT OVERTIGHTEN.**

3. On the opposite side of the swivel caster plate, insert 2 carriage bolts through the compressor support rail and swivel caster plate. Use a lock nut on each bolt and tighten securely using a 9/16" socket wrench. See Figure 5.

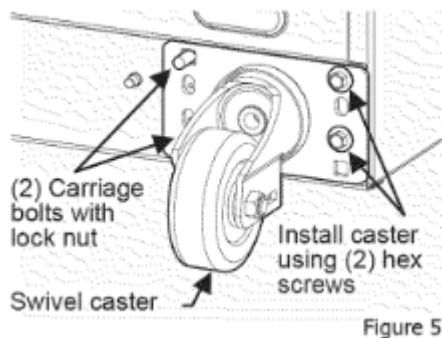

4. Repeat the same procedure for the opposite rear corner.

5. With the help of an assistant, carefully upright the unit. Reassemble the rear access guard with screws.

## Appliance Placement

Leave a 1" space on all sides and the back of the cabinet for ease of installation, proper air circulation and electrical connections. **DO NOT** block the front grill on the lower front of your appliance. Sufficient air circulation is essential for the proper operation of your appliance. Choose a place that is near a grounded electrical outlet. For the most efficient operation, the appliance should be located where surrounding temperatures will not drop below 40°F (5°C) or exceed 110°F (43°C). Additional compressor heaters are not recommended.

## Insulation

The insulated space of this cabinet is sealed to maintain peak efficiency. Holes drilled in the cabinet may destroy that seal and damage electrical wiring located in the insulated space. **DAMAGED ELECTRICAL WIRING OR WET INSULATION CAUSED BY DRILLING WILL VOID THE WARRANTY.**

### Reversing Door

This appliance features a door that can provide either left hand or right hand opening. It comes from the factory with right hand position.

Follow these steps to reverse the opening:

1. With the appliance in a standing upright position, open the door and remove the toe plate (2 screws in the upper corners).
2. Slightly loosen the 2 hex spacers that the toe plate screws were screwed into.

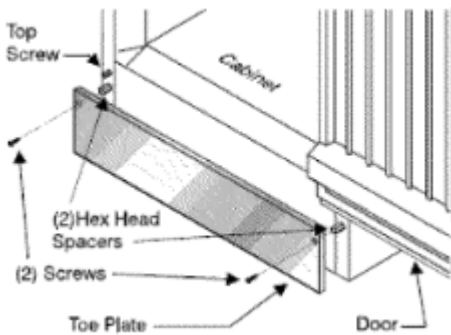

3. Holding door securely closed; remove 2 hex head screws from the top hinge.
4. Lift appliance door off of bottom hinge and set aside in a safe place so it does not fall.

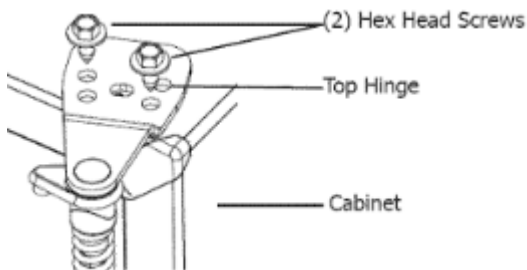

5. Remove top screws from bottom hinge. Remove top screw from opposite side of appliance.
6. Slide bottom hinge onto hex spacer and attach top screw to cabinet. Retighten both hex spacers.

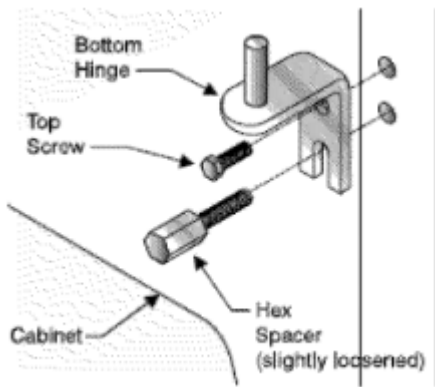

7. Remove top hinge assembly from the door and reverse the position making sure the pegs are properly seated in the peg holes.
8. Rotate the door 180° and re-install on bottom hinge. Hold door in closed position.
9. Rotate the top hinge to align the mounting holes. Reposition the hinge to
10. Install plugs in each of the hinge holes on opposite side on the cabinet.
11. Re-install toe plate with 2 screws.

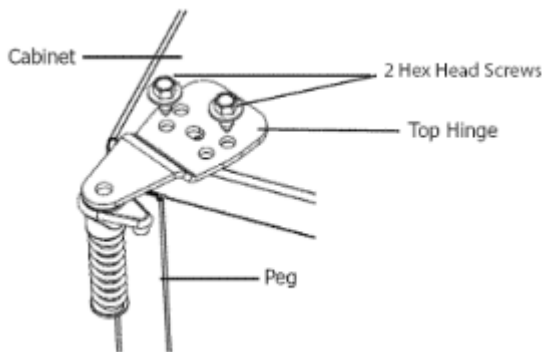

## Door Lock

### NOTE

The lock strike should angle out and away from the cabinet.

1. Install the lock strike on the lock side of the cabinet using the 3 tamper resistant screws. Install the 3 remaining buttons in the holes on the opposite side of the cabinet.
2. Install the lock guard in the side of the door cabinet by installing the 2 screws into the corresponding screw holes.

### CAUTION

The tamper resistant screws cannot be removed after the lock strike is secured to the cabinet.

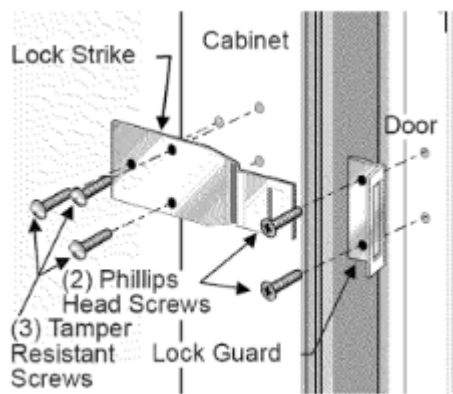

## Appliance Start-up

Once the appliance has been located in its permanent location and the proper power and grounding has been provided, the following items must be checked or completed:

### Cool Down Period

For safe food storage, allow 24 hours for the appliance to cool down completely before loading with food. The appliance will run continuously for the first several hours. Do not place any food in the appliance until after the first 24 hours of operation.

### Thermostat Setting

The appliance is shipped from the factory with the thermostat set at about the mid- point of the operating range. Adjustments colder or warmer can be made after the appliance has been running for at least 8 hours. Allow at least 8 hours for temperature stabilization before re- adjusting the thermostat.

### Defrost Setting

The appliance is designed to defrost automatically every 12 hours. To set the time of defrost, wait until the desired time to defrost. With the notch on the timer knob aligned with the line on the bracket (Figure 6), turn the defrost timer knob clockwise slowly. The timer will click several times, then once loudly, at which point the defrost cycle begins. The timer knob will advance through the defrost cycle, then click loudly at the end of the cycle. The appliance will defrost automatically every 12 hours after the first defrost cycle.

For example, to set the appliance to defrost at 10:00 AM, turn the timer knob clockwise at 10:00 AM until the timer clicks loudly. The appliance will defrost daily at 10:00 AM and again 12 hours later at 10:00 PM. NOTE: The appliance interior temperature will rise slightly during the first defrost cycle.

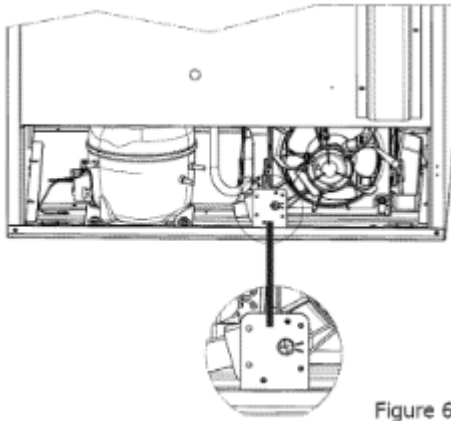

Figure 6

Figure 6

## Features

- NSF-certified top-mounted evaporator
- 2 - 1/2" urethane foam cabinet insulation
- Torsion-spring door closer
- Heavy-duty fixed and swivel casters
- 17-watt fluorescent lamp
- Stainless steel evaporator housing
- Removable stainless steel drain cover
- Adjustable temperature control
- NSF-certified interior
- Heavy-duty front grill
- Heavy-duty commercially rated electrical harness

This appliance is provided with 4 shelves. One goes on the floor of the cabinet and the other 3 are placed in the metal side supports wherever they are needed. The shallow shelf goes in the upper position.

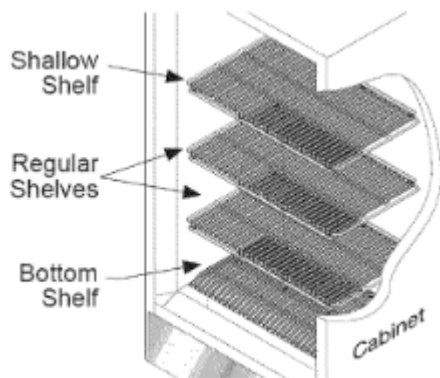

## Castors

The appliance comes with 4 casters; 2 with locks for the front of the unit and 2 without locks for the back of the unit. The casters allow you to move the unit to it's final destination with ease. The casters can then be locked into place. Refer to the First Steps section for caster installation instructions.

### **Reversible Door Lock**

The appliance comes with an outer cabinet mounted door lock and two keys. The lock can be mounted on either side of the appliance depending on which side the door swings open. A door mounted lock has been provided for added security. (Refer to Reversing Door for instructions.)

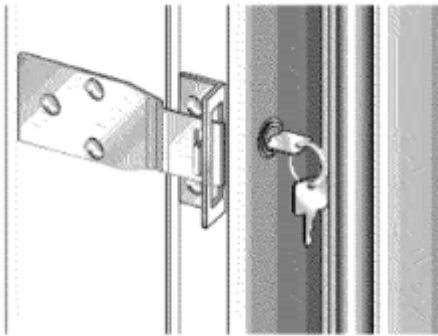

### **Adjustable Temperature Control**

The adjustable cold control is located on the top left panel inside the unit.

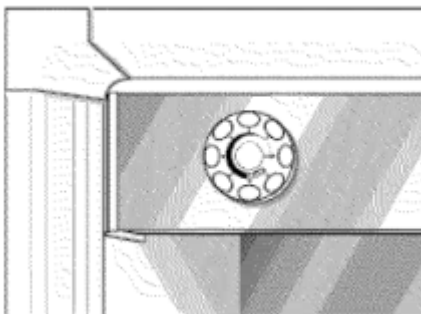

### **NSF-Certified Temperature Gauge**

This appliance is equipped with an NSF- certified temperature gauge to display cabinet internal temperature. The temperature gauge is located on the top right side of the evaporator housing inside the unit.

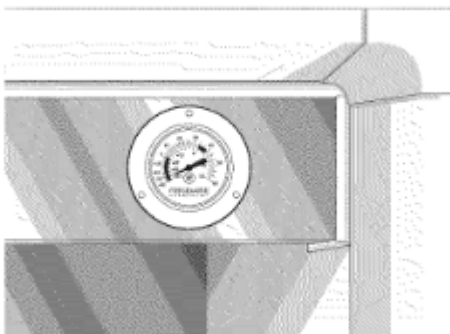

### **Fluorescent Lamp (glass door models)**

The Glass Door Refrigerator is equipped with a 17 watt fluorescent lamp. A ballast - lamp mismatch may result in poor or no lighting.

If the lamp fails, replace with a lamp of the same type and wattage. Also, replace a lamp that flickers continuously. This could damage the ballast.

Turning the light off, when not in use, will save energy. However, frequent ON- OFF cycling will reduce the lamp life.

Use only NSF certified lamp which can be ordered from your Frigidaire Commercial Service Center by calling 1- 866- 738- 1640.

### **Interior Thermometer**

The appliance comes with a thermometer to show the internal temperatures. The thermometer is to be hung from the top adjustable shelf on the right hand side.

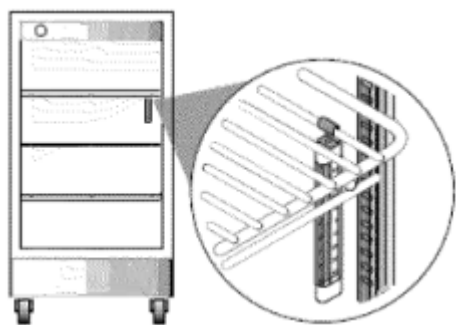

### **Interior Light (stainless steel door models)**

The appliance is equipped with a 40- watt bulb that lights up when the door is opened. If bulb goes bad replace with bulb of same type and wattage. This is a special bulb with shatterproof coating. Use an NSF certified bulb of the same type and wattage (can be ordered from your Customer Service Center by calling 1- 866- 738- 1640).

## **Care and Cleaning**

### **Cleaning the Interior**

Be sure to turn the temperature control to "OFF" and unplug the electrical cord. Wash the inside surface of the storage area with a solution of 1 tbsp. (12 g) of baking soda in 1 qt. (1 l) warm water. Rinse thoroughly with clean, warm water and wipe dry. The procedure can also be used for cleaning the door gasket. Wipe the stainless steel cover plates with Magic Clean Stainless Steel Cleaner (can be ordered from your Customer Service Center by calling 1- 866- 738- 1640), or some other stainless steel cleaner.

### **Cleaning the Exterior**

Wipe the textured cabinet exterior occasionally with a cloth dampened in mild detergent and water. Rinse and wipe dry with a soft cloth. Wipe the stainless steel door plate and toe grill with Magic Clean Stainless Steel Cleaner or some other stainless steel cleaner. Do not use razor blades or other sharp instruments that can scratch the appliance surface when removing adhesive labels. Any glue left from the tape can be removed with a mixture of warm water and mild detergent or touch the residue with the sticky side of tape already removed. **DO NOT REMOVE THE SERIAL PLATE.**

### **Condensate Pan**

The condensate pan is in a fixed position and must not be removed from under the cabinet. If the pan is removed, condensate will drop onto the floor.

### **Periods of Non-use and Moving Tips**

Leave the appliance operating during periods of non- use of less than 3 weeks.

#### **Long Periods of Non-use**

If the appliance will not be used for several months:

Remove all food and unplug the power cord. Clean and dry the interior thoroughly. Leave the appliance door open slightly, blocking it open if necessary, to prevent odor and mold growth.

#### **Moving**

When moving the appliance, follow these guidelines to prevent damage:

Disconnect the power cord plug from the wall outlet. Remove foods, then defrost, and clean the appliance. Secure all loose items such as base panel, baskets, and shelves by taping them securely in place to prevent damage. In the moving vehicle, secure appliance in an upright position to prevent movement. Also, protect outside of appliance with a blanket or similar item.

### **Power Failure**

**DO NOT** open the appliance lid unnecessarily if the appliance is off for several hours.

If a power failure occurs, pack 7 or 8 pounds of dry ice into the freezer every 24 hours. Look in the Yellow Pages under "Dry Ice," "Dairies," or "Ice Cream Manufacturers" for local dry ice suppliers. Always wear gloves and use caution when handling dry ice.

### **Energy-Saving Tips**

This appliance is designed for efficiency with heavy foam insulation. However, there are things that the user can do to maintain the appliance in operating condition.

Do not operate the appliance any colder than necessary to maintain safe, product storage temperatures. Make sure the appliance is located to prevent direct exposure to sunlight, air ducts, etc. Keep the lid closed except for normal use. Inspect the door often to see that it selfcloses and

the gaskets are in good condition. Do not overstock the product in the cabinet because it will block the normal air flow. Have at least annual inspections by a qualified service company to see that the refrigerant charge is correct. This appliance operates more efficiently in a cooler ambient than in a hot ambient. Try to maintain an ambient below 80°F (27°C) and 65% RH (Relative Humidity) for maximum efficiency.

## Before You Call

### TROUBLESHOOTING GUIDE

Before calling for service, review this list. It may save you time and expense. This list includes common occurrences that are not the result of defective workmanship or materials in this appliance.

#### PROBLEM: APPLIANCE OPERATION

Appliance does not run.

CAUSE: ·Appliance is plugged into a circuit that has a ground fault interrupt. ·Temperature control is in the "OFF" position. ·Appliance may not be plugged in, or plug may be loose. ·Fuse blown or tripped circuit breaker. ·Power outage.

CORRECTION: ·Use another circuit. If you are unsure about the outlet, have it checked by a certified technician. ·See Thermostat Setting. ·Ensure plug is tightly pushed into outlet. ·Check/replace fuse with a 15-amp time delay fuse. Rest circuit breaker. ·Check house lights. Call local electric company.

Appliance runs too much or too long.

CAUSE: ·Room or outside weather is hot. ·Appliance has recently been disconnected for a period of time. ·Large amount of warm or hot food have been stored recently. ·Door is opened too frequently or kept open too long. ·Appliance door may be slightly ajar. ·Temperature control is set too low. ·Appliance gaskets are dirty, worn, cracked or poorly fitted.

CORRECTION: ·It's normal for the appliance to work harder under these conditions. ·It takes 24 hours for the appliance to cool down completely. ·Warm food will cause appliance to run more until the desired temperature is reached. ·Warm air entering the appliance causes it to run more. Open the door less often. ·See "Door Problems". ·Turn control knob to a warmer setting. Allow several hours for the temperature to stabilize. ·Clean or change gasket. Leaks in the lid seal will cause appliance to run longer in order to maintain desired temperature.

Interior appliance temperature is too cold.

CAUSE: ·Temperature control is set too low.

CORRECTION: ·Turn control knob to a warmer setting. Allow several hours for the temperature to stabilize.

Interior appliance temperature is too warm.

CAUSE: ·Temperature control is set too warm. ·Door is open too frequently or kept open too long.  
·Large amount of warm or hot food have been stored recently. ·Appliance has recently been disconnected for a period of time.

CORRECTION: ·Turn control knob to a colder setting. Allow several hours for the temperature to stabilize. ·Warm air entering the appliance causes it to run more. Open the door less often. ·Wait until the appliance has had a chance to reach its selected temperature. ·Appliance requires 24 hours to cool down completely.

Appliance external surface temperature is warm.

CAUSE: ·The external appliance walls can be as much as 30°F warmer than room temperature.

CORRECTION: ·This is normal while the compressor works to transfer heat from inside the appliance cabinet.

### **PROBLEM: SOUND AND NOISE**

Louder sound levels whenever appliance is on.

CAUSE: • Modern appliances have increased storage capacity and more stable temperatures. They require heavy-duty compressors.

CORRECTION: • This is normal. When the surrounding noise level is low, you may hear the compressor running while it cools the interior.

Louder sound levels when compressor comes on.

CAUSE: • Appliance operates at higher pressures during the start of the ON cycle.

CORRECTION: • This is normal. Sound will level off or disappear as appliance continues to run.

Popping or cracking sound when compressor comes on.

CAUSE: • Metal parts undergo expansion and contraction, as in hot water pipes.

CORRECTION: • This is normal. Sound will level off or disappear as appliance continues to run.

Bubbling or gurgling sound.

CAUSE: • Refrigerant (used to cool appliance) is circulating throughout the system.

CORRECTION: • This is normal.

Vibrating or rattling noise.

CAUSE: • Appliance is not level. It rocks on the floor when it is moved slightly.

- Floor is uneven or weak.
- Appliance is touching the wall.

CORRECTION: • Level the appliance by putting wood or metal shims under part of the appliance.

- Ensure floor can adequately support appliance. Level the appliance.
- Re-level appliance or move appliance slightly.

### **PROBLEM: WATER/MOISTURE/FROST INSIDE APPLIANCE**

Moisture forms on inside appliance walls.

CAUSE: • Weather is hot and humid, which increases internal rate of frost build-up.

CORRECTION: • This is normal.

### **PROBLEM: ODOR IN APPLIANCE**

Odors in appliance.

CAUSE: • Interior needs to be cleaned.

• Food with strong odors are in the appliance.

CORRECTION: • Clean interior with sponge, warm water, and baking soda.

• Cover the food tightly.

### **PROBLEM: DOOR PROBLEMS**

Door will not close.

CAUSE: • Appliance is not level. It rocks on the floor when it is moved slightly.

• Floor is uneven or weak.

CORRECTION: • Level the appliance by putting wood or metal shims under part of the appliance.

• Ensure floor can adequately support appliance. Level the appliance by putting wood or metal shims under part of the appliance.

### **PROBLEM: LIGHTING PROBLEMS**

Fluorescent lamp is not on.

CAUSE: • The fluorescent lamp is burned out.

• No electric current is reaching the appliance.

CORRECTION: • See "Fluorescent Lamp" in Features section.

• See "Appliance does not run".

FOR QUESTIONS, COMMENTS OR SERVICE PLEASE CALL US TOLL FREE AT  
1-866-738-1460.

## **Wiring Diagram**

### **IMPORTANT SAFETY NOTICE**

The information provided herein is designed to assist qualified repair personnel only. Untrained persons should not attempt to make repairs due to the possibility of electrical shock. Disconnect the power cord before servicing.

ELECTRICAL CIRCUIT

STAINLESS STEEL DOOR REFRIGERATOR

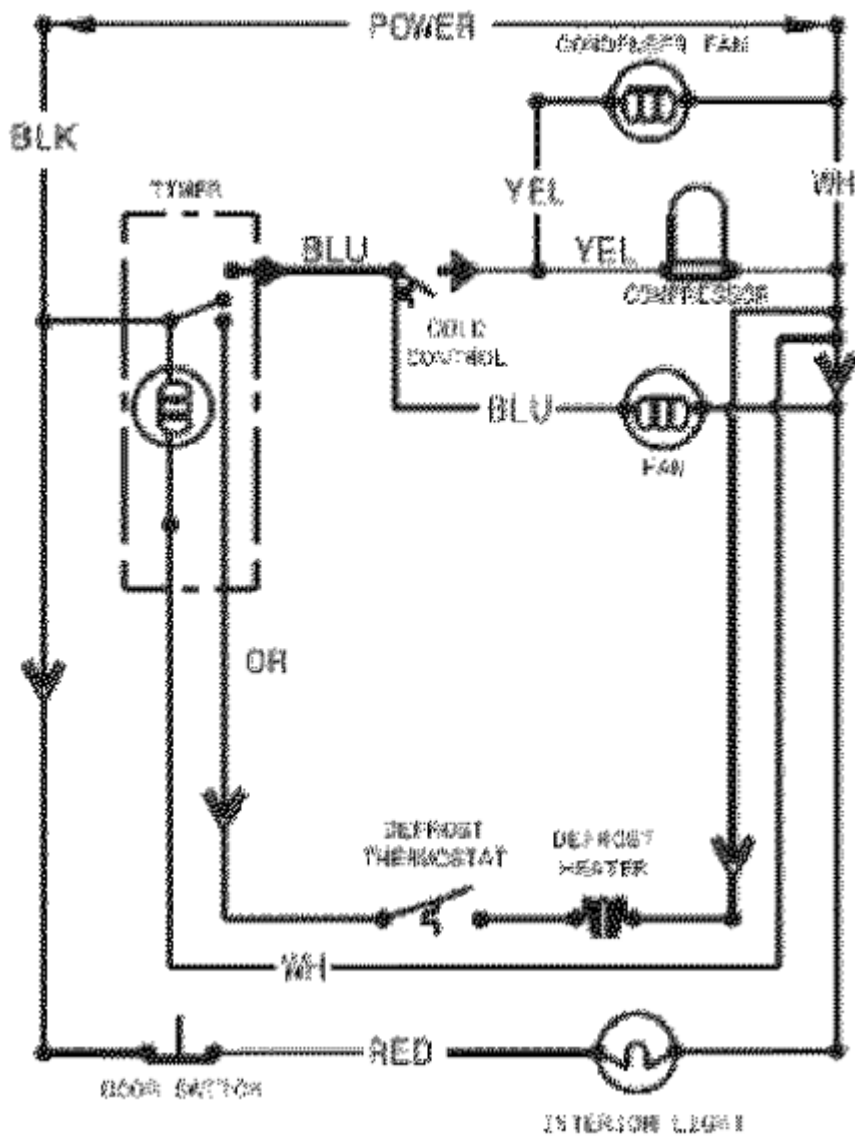

STAINLESS STEEL DOOR FREEZERS



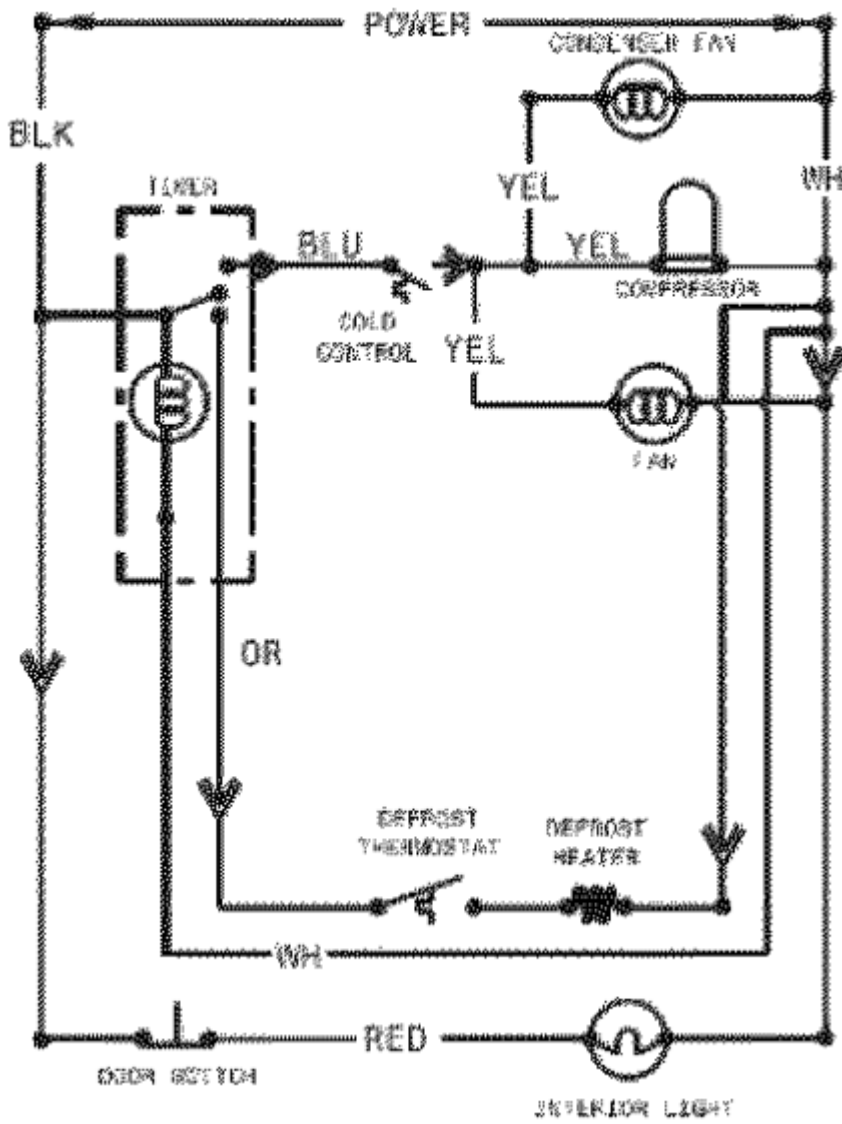

GLASS DOOR REFRIGERATOR



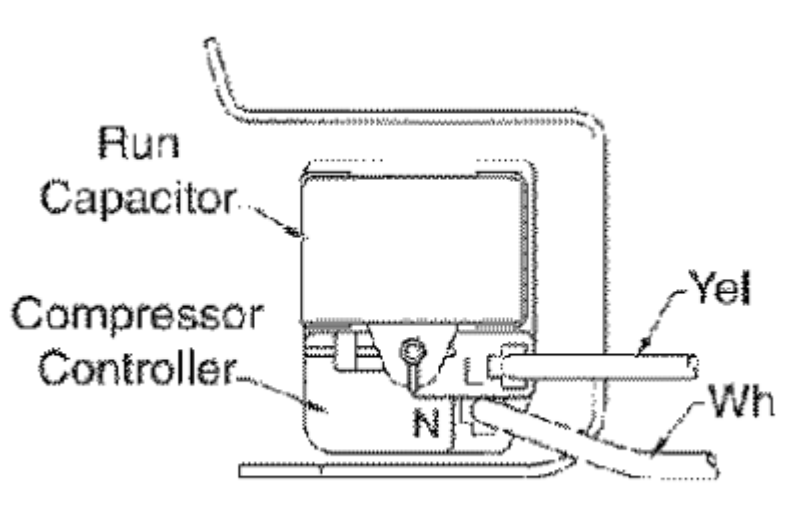
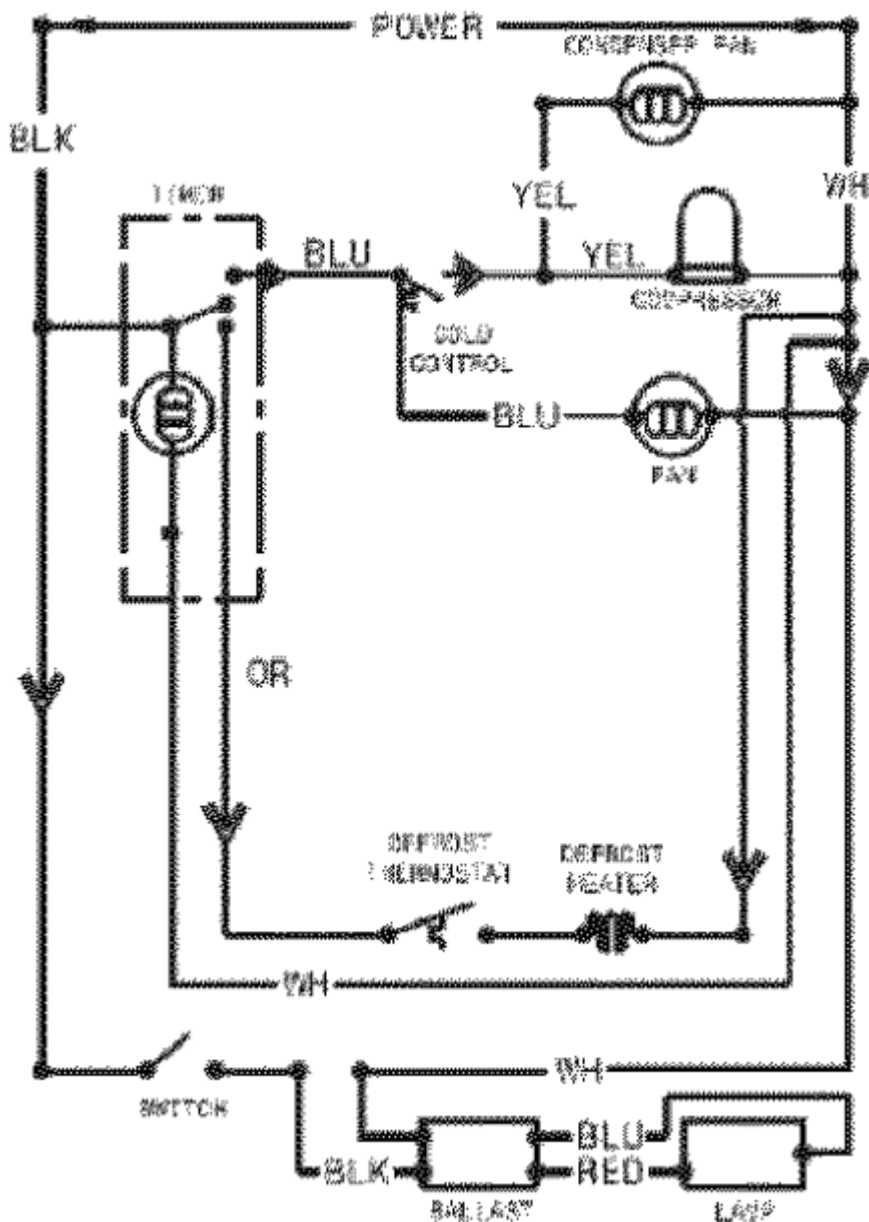

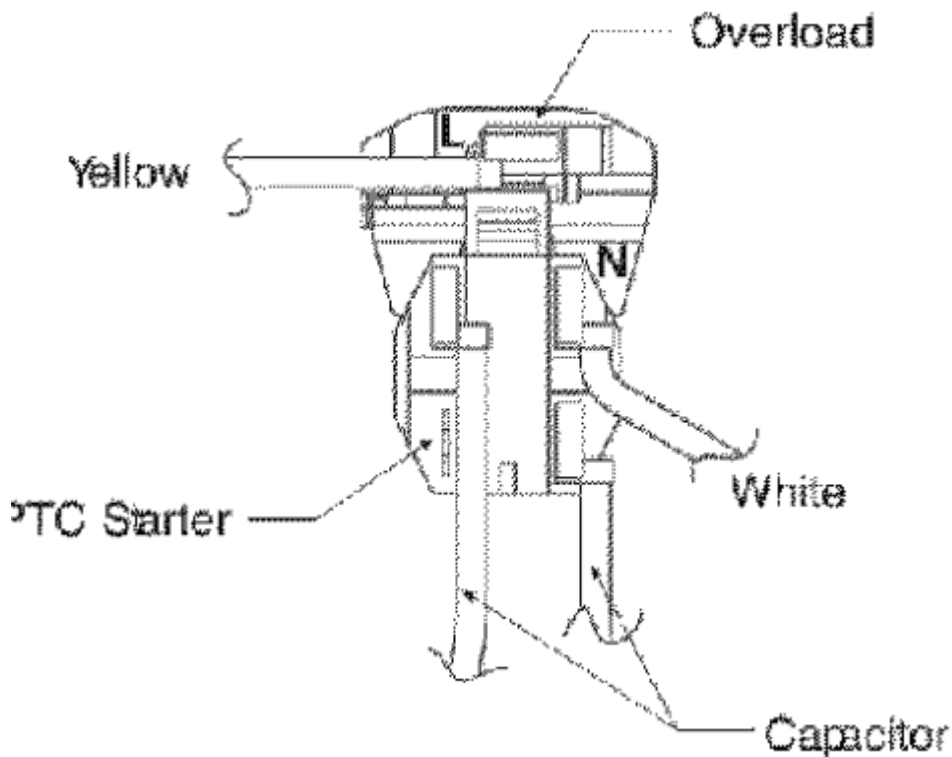

### **IMPORTANT**

IF ANY GREEN GROUNDING WIRES ARE REMOVED DURING SERVICING, THEY MUST BE RETURNED TO THEIR ORIGINAL POSITION AND PROPERLY SECURED.

## **Warranty**

Your appliance is covered by a three (3) year limited warranty. For three (3) years from your original date of purchase, Electrolux will pay all costs, except as set forth below, for repairing or replacing any parts of this appliance that prove to be defective in materials or workmanship when such appliance is installed, used, and maintained in accordance with the provided instructions. For appliances that are manufactured with a compressor, an additional two (2) year part warranty is provided for the compressor only.

### **Exclusions**

This warranty does not cover the following:

1. Products where the original serial number has been removed, altered or cannot be readily determined.
2. Normal wear and tear and gradual deterioration.
3. Product that has been transferred from its original owner to another party or moved outside the USA or Canada.
4. Rust on the interior or exterior of the unit.
5. Products purchased "as-is".

6. Food loss due to any refrigerator or freezer failures.
7. Damage caused at any time during shipment.
8. Service calls which do not involve malfunction or defects in materials or workmanship, or for appliances used other than in accordance with the provided instructions.
9. Service calls to correct the installation of your appliance or to instruct you how to use your appliance.
10. Expenses for making the appliance accessible for servicing, such as removal of trim, cupboards, shelves, etc., which are not a part of the appliance when it is shipped from the factory.
11. Service calls to replace appliance light bulbs, air filters, water filters, and other consumables, or knobs, handles, and other cosmetic parts.
12. Surcharges including, but not limited to, any after hours, weekend, or holiday service calls, tolls, ferry trip charges, or mileage expense for service calls to remote areas, including the state of Alaska.
13. Damages to the finish of the appliance and/or the appliance location that are incurred during installation, including but not limited to floors, cabinets, walls, etc.
14. Damages caused by: services performed by unauthorized service companies; use of parts other than genuine Electrolux parts or parts obtained from persons other than authorized service companies; or external causes such as abuse, misuse, inadequate power supply, accidents, fires, or acts of God.
15. For appliances operated by a concessionaire or vendor in a trailer or other motorized vehicle, or at varying locations, your appliance is covered by a one (1) year, limited parts and labor warranty. For appliances that are manufactured with a compressor, an additional four (4) year part warranty is provided for the compressor only.

#### **DISCLAIMER OF IMPLIED WARRANTIES; LIMITATION OF REMEDIES**

CUSTOMER'S SOLE AND EXCLUSIVE REMEDY UNDER THIS LIMITED WARRANTY SHALL BE PRODUCT REPAIR OR REPLACEMENT AS PROVIDED HEREIN. CLAIMS BASED ON IMPLIED WARRANTIES, INCLUDING WARRANTIES OF MERCHANTABILITY OR FITNESS FOR A PARTICULAR PURPOSE, ARE LIMITED TO ONE (1) YEAR OR THE SHORTEST PERIOD ALLOWED BY LAW, BUT NOT LESS THAN ONE (1) YEAR. ELECTROLUX SHALL NOT BE LIABLE FOR CONSEQUENTIAL OR INCIDENTAL DAMAGES SUCH AS PROPERTY DAMAGE AND INCIDENTAL EXPENSES RESULTING FROM ANY BREACH OF THIS WRITTEN LIMITED WARRANTY OR ANY IMPLIED WARRANTY. SOME STATES AND PROVINCES DO NOT ALLOW THE EXCLUSION OR LIMITATION OF INCIDENTAL OR CONSEQUENTIAL DAMAGES, OR LIMITATIONS ON THE DURATION OF IMPLIED WARRANTIES, SO THESE LIMITATIONS OR EXCLUSIONS MAY NOT APPLY TO YOU. THIS WRITTEN WARRANTY GIVES YOU SPECIFIC LEGAL RIGHTS. YOU MAY ALSO HAVE OTHER RIGHTS THAT VARY FROM STATE TO STATE.



## If You Need Service

Keep your receipt, delivery slip, or some other appropriate payment record to establish the warranty period should service be required. If service is performed, it is in your best interest to obtain and keep all receipts. Service under this warranty must be obtained by contacting Electrolux at the addresses or phone numbers below.

This warranty only applies in the USA and Canada. In the USA, your appliance is warranted by Electrolux Major Appliances North America, a division of Electrolux Home Products, Inc. In Canada, your appliance is warranted by Electrolux Canada Corp. Electrolux authorizes no person to change or add to any obligations under this warranty. Obligations for service and parts under this warranty must be performed by Electrolux or an authorized service company. Product features or specifications as described or illustrated are subject to change without notice.

A00915201/A (January 2014)

USA 1.866.738.1640 Electrolux Major Appliances North America 10200 David Taylor Drive  
Charlotte, NC 28262

Canada 1.800.265.8352 Electrolux Canada Corp. 5855 Terry Fox Way Mississauga, Ontario,  
Canada L5V 3E4

### Warning

This content is compiled from multiple sources and is provided for reference purposes only. It may not be complete or fully applicable to all situations. If you are unable to resolve your issue, please contact the product manufacturer or an authorized service provider for official support.