

# User Guide for Whirlpool WRS315SDHZ01

## Table of Contents

# OPERATING YOUR REFRIGERATOR

## Using the Controls

For your convenience, your refrigerator controls are preset at the factory. When you first install your refrigerator, make sure that the controls are still preset. The Refrigerator Control and the Freezer Control should both be set to the “mid-settings.”

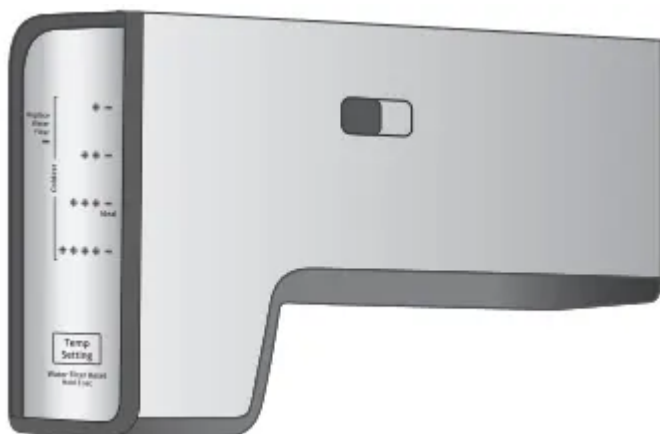

### REFRIGERATOR.

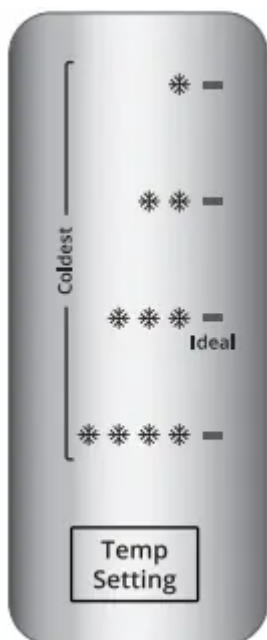

### FREEZER



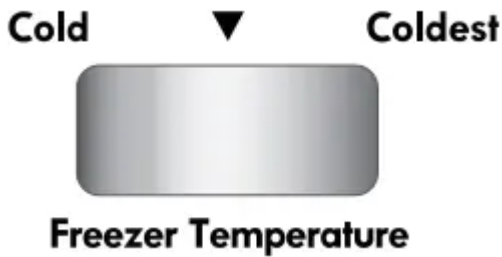

**IMPORTANT:**

- The Refrigerator Control adjusts the refrigerator compartment temperature. Every click on “Temp Setting” button makes refrigerator compartment colder, once you get to the last level the system will go back to the initial level.

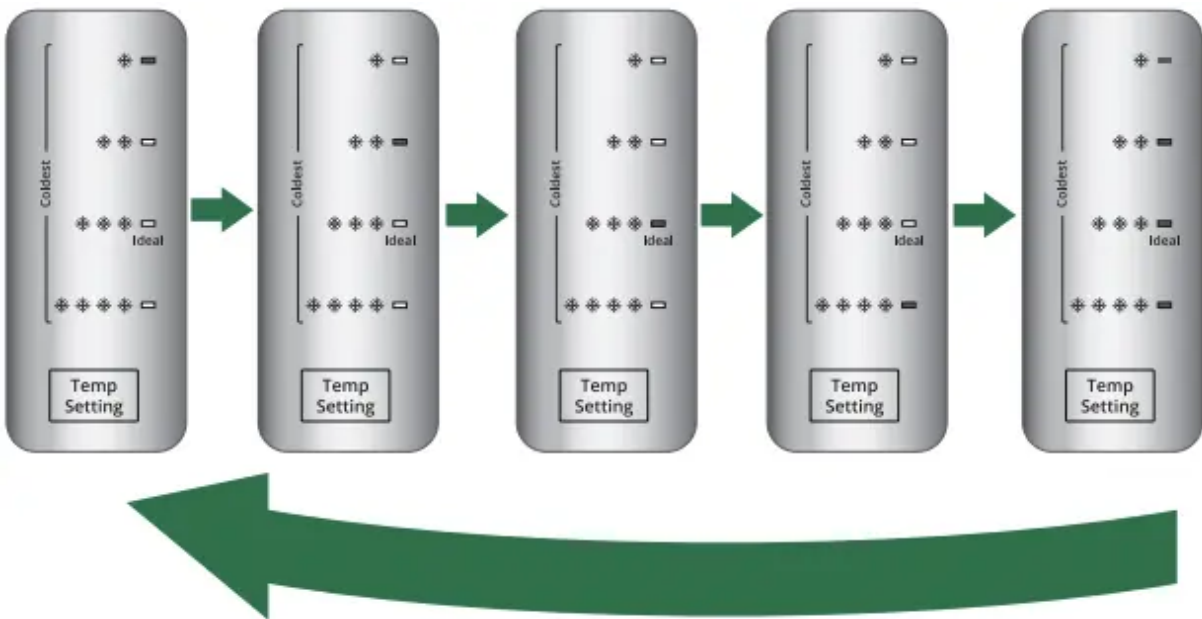

- The Freezer Control adjusts the freezer compartment temperature. Settings to the front of the mid-setting make the temperature less cold. Settings to the back of the mid-setting make the temperature colder.
- Wait 24 hours before you put food into the refrigerator. If you add food before the refrigerator has cooled completely, your food may spoil.

**NOTE:** Adjusting the Refrigerator and Freezer Controls to a higher (colder) than recommended setting will not cool the compartments any faster.

**Adjusting Controls**

Give the refrigerator time to cool down completely before adding food. It is best to wait 24 hours before you put food into the refrigerator. The settings indicated in the previous section should be correct for normal household refrigerator usage. The controls are set correctly when milk or juice is as cold as you like and when ice cream is firm. If you need to adjust temperatures in the refrigerator or freezer, use the settings listed in the chart below as a guide. Wait at least 24 hours between adjustments.



REFRIGERATOR too warm : REFRIGERATOR Control one setting higher

FREEZER too warm/ too little ice : FREEZER Control one setting higher

REFRIGERATOR too cold : REFRIGERATOR Control one setting lower

FREEZER too cold. : FREEZER Control one setting lower

## **Crisper Humidity Control (on some models)**

You can control the amount of humidity in the moisture-sealed crisper. Adjust the control to any setting between LOW and HIGH.

**LOW** (open) for best storage of fruits and vegetables with skins.

**HIGH** (closed) for best storage of fresh, leafy vegetables.

## **ICE AND WATER**

### **Water and Ice Dispensers**

#### **NOTES:**

- The dispensing system will not operate when either door (refrigerator or freezer) is open.
- Allow 24 hours for the refrigerator to cool down and chill water.
- Allow 24 hours to produce the first batch of ice. Discard the first three batches of ice produced. Wait 72 hours for full ice production.

#### **Flush the Water System**

Air in the water dispensing system can cause the water dispenser to drip. After connecting the refrigerator to a water source or replacing the water filter, flush the water system. Flushing the water dispensing system forces air from the water line and filter, and prepares the water filter for use.

**NOTE:** As air is cleared from the system, water may spurt out of the dispenser.

1. Using a sturdy container, depress and hold the water dispenser lever for 5 seconds, then release it for 5 seconds.
2. Repeat Step 1 until water begins to flow.
3. Once water begins to flow, continue depressing and releasing the dispenser lever (5 seconds on, 5 seconds off) until a total of 3 gal. (12 L) has been dispensed.

Additional flushing may be required in some households.

#### **The Water Dispenser**

#### **IMPORTANT:**

- Dispense at least 1 qt (1 L) of water every week to maintain a fresh supply.

- If the flow of water from the dispenser decreases, it could be caused by low water pressure.
- With the water filter removed, dispense 1 cup (237 mL) of water. If 1 cup of water is dispensed in 8 seconds or less, the water pressure to the refrigerator meets the minimum requirement.
- If it takes longer than 8 seconds to dispense 1 cup of water, the water pressure to the refrigerator is lower than recommended. See “Water Supply Requirements” (in the User Instructions or the Installation Instructions and Owner’s Manual) or “Troubleshooting” for suggestions.

### To Dispense Water:

1. Press a sturdy glass against the water dispenser lever. Hold the glass close to the water dispenser spout to ensure that the water dispenses into the glass.
2. Remove the glass to stop dispensing.

**IMPORTANT:** The small tray at the bottom of the dispenser is designed to catch small spills and allow for easy cleaning. There is no drain in the tray.

### The Ice Dispenser

Ice dispenses from the ice maker storage bin in the freezer when the dispenser lever is pressed. To turn off the ice maker, see “Ice Maker and Storage Bin.” Your ice maker can produce both crushed and cubed ice. Before dispensing ice, select which type of ice you prefer.

- Press the CRUSHED button for crushed ice, or the CUBED button for cubed ice.

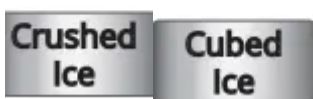

For crushed ice, cubes are crushed before being dispensed. This may cause a slight delay when dispensing crushed ice. Noise from the ice crusher is normal, and pieces of ice may vary in size.

When changing from crushed to cubed, a few ounces of crushed ice will be dispensed along with the first cubes.

### To Dispense Ice:

1. Press the button to select the desired type of ice.



**Cut Hazard** Use a sturdy glass when dispensing ice. Failure to do so can result in cuts.

2. Press a sturdy glass against the ice dispenser lever. Hold the glass close to the ice guide to ensure that the ice dispenses into the glass.

**IMPORTANT:** You do not need to apply a lot of pressure to the lever in order to activate the ice dispenser. Pressing hard will not make the ice dispense faster or in greater quantities.

3. Remove the glass to stop dispensing.

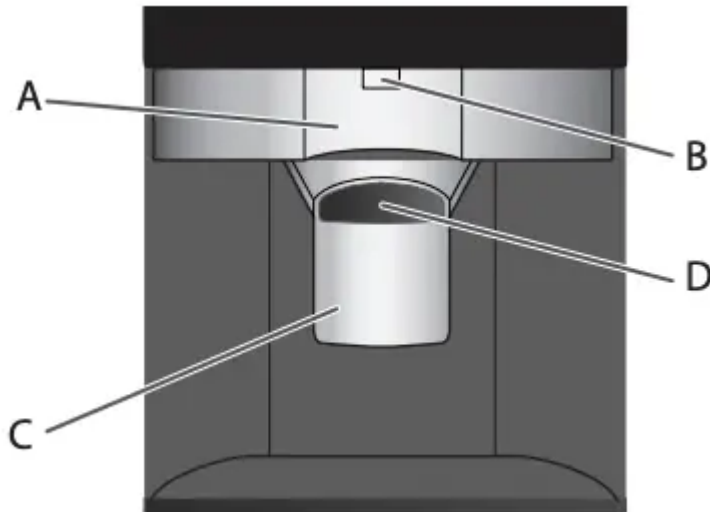

- A. Water dispenser lever
- B. Water dispenser spout
- C. Ice dispenser lever
- D. Ice guide

### **The Dispenser Light**

On some models, the dispenser light will automatically turn on when you use the dispenser.

- If you want the light to be on continuously, press the LIGHT ON button. To turn the light back off, press the LIGHT OFF button.



The dispenser lights are LEDs that cannot be changed. If it appears that your dispenser lights are not working, see “Troubleshooting” for more information.

### **The Dispenser Lock**

The dispenser can be turned off for easy cleaning or to avoid unintentional dispensing by small children and pets.

**NOTE:** The lock feature does not shut off power to the refrigerator, to the ice maker, or to the dispenser light. It simply deactivates the dispenser lever. To turn off the ice maker, see “Ice Maker and Storage Bin.”

- To lock the dispenser, press the LOCK button. To unlock the dispenser, press the UNLOCK button.

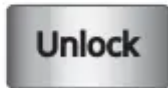
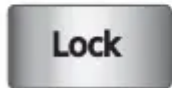

## Ice Maker and Storage Bin

- Allow 24 hours to produce the first batch of ice. Discard the first three batches of ice produced.
- The quality of your ice will be only as good as the quality of the water supplied to your ice maker. Avoid connecting the ice maker to a softened water supply. Water softener chemicals (such as salt) can damage parts of the ice maker and lead to poor quality ice. If a softened water supply cannot be avoided, make sure the water softener is operating properly and is well maintained.
- Do not use anything sharp to break up the ice in the storage bin. This can cause damage to the ice container and the dispenser mechanism.
- Do not store anything on top of or in the ice maker or storage bin.

### Turning the Ice Maker On/Off

#### Style 1

- To turn on the ice maker, lift open the ice maker door and lower the wire shutoff arm to the ON position.
- To manually turn off the ice maker, lift the wire shutoff arm to the OFF (arm up) position and listen for the click. Ice can still be dispensed, but no more can be made.

**NOTE:** Your ice maker has an automatic shutoff. As ice is made, the ice cubes will fill the ice storage bin, and the ice cubes will raise the wire shutoff arm to the OFF (arm up) position. Do not force the wire shutoff arm up or down.

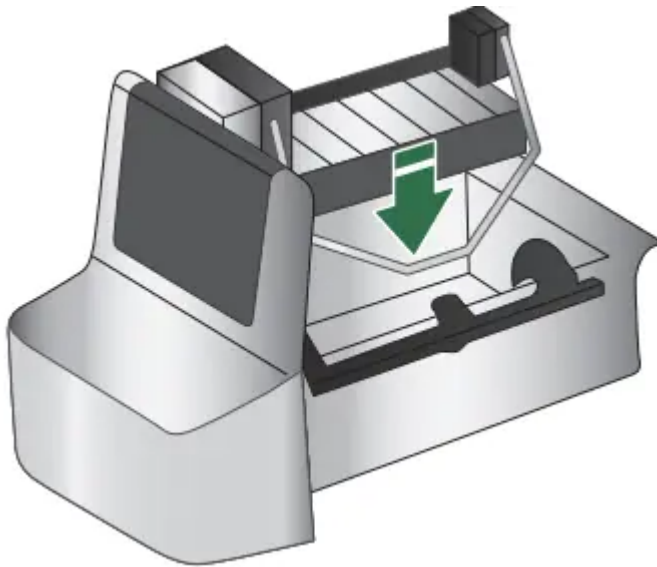

### **Removing and Replacing the Ice Storage Bin**

1. Lift and hold open the ice maker door.
2. Lift the wire shutoff arm so it clicks into the OFF (up) position. Release the ice maker door.
3. Lift up the front of the storage bin and pull it out.
4. Replace the bin by pushing it in all the way, or the dispenser will not work.
5. To restart ice production, lift open the ice maker door and push the wire shutoff arm down to the ON position.

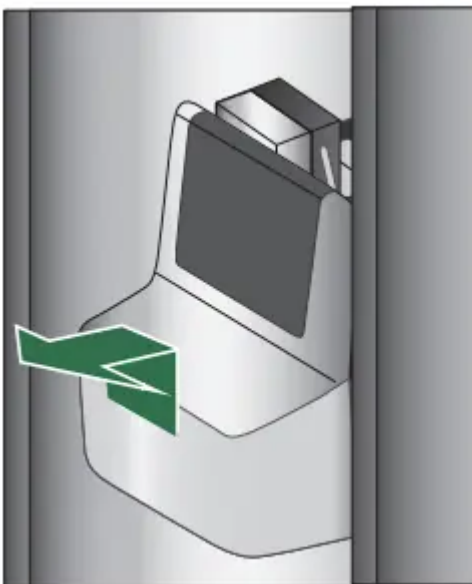

### **Style 2**

The On/Off switch is located on the bottom of the Ice Maker. can be accessed by lifting and opening the ice maker door.

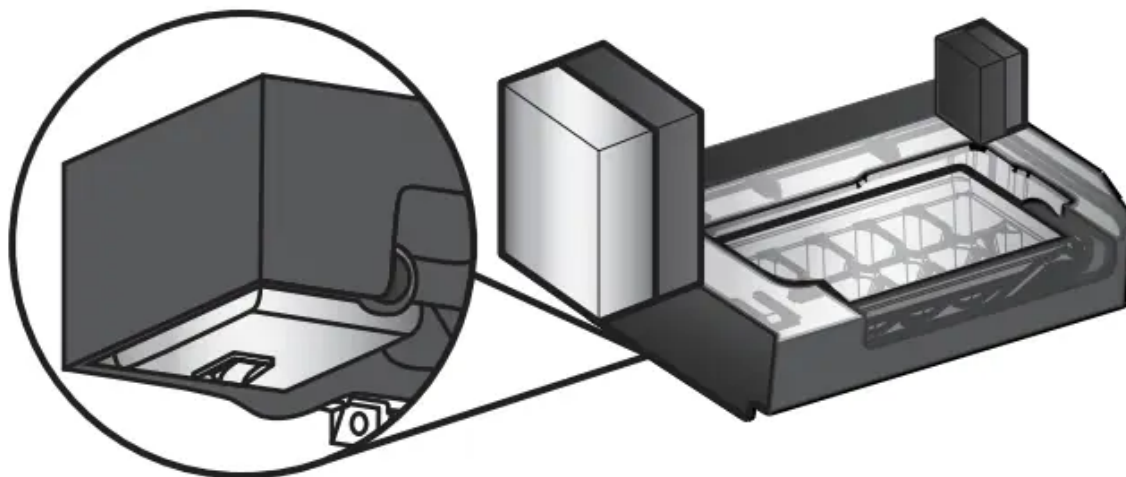

- To turn on the ice maker. lift open the ice maker door. flip the switch to the ON (right) position.
- To manually turn off the ice maker. lift open the ice maker door. flip the switch to the Off (left) position. Ice can still be dispensed. but no more can be made.

**NOTE:** Your ice maker has an automatic shutoff to keep the storage bin from overflowing during normal operation. As ice is made. the ice cubes will fill the ice storage bin. and the ice cubes will raise the shutoff arm to the OFF (arm up) position. When the storage bin is at full capacity. the ice maker will automatically stop ice production. but the ice maker On/Off switch will remain in the On (up) position.

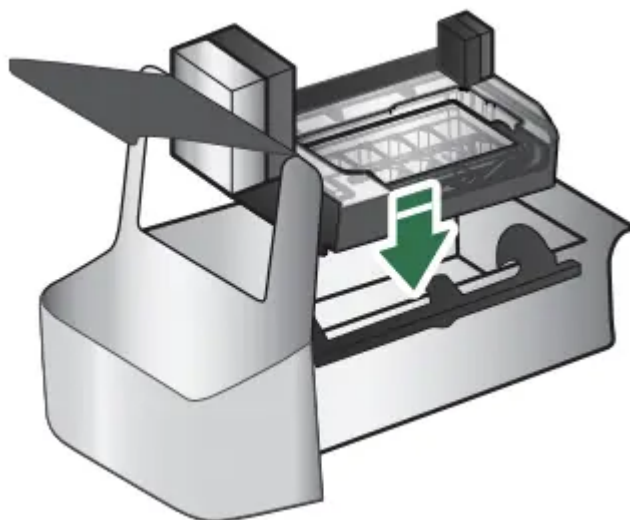

### **Removing and Replacing the Ice Storage Bin**

1. Pull the covering panel up from the bottom .
2. Lift the plastic shutoff arm so it clicks into the Off (up) position.
3. Lift up the front of the storage bin and pull it out.
4. Replace the bin by pushing it in all the way or the dispenser will not work.

5. To restart ice production, lower the plastic shutoff arm into the On (down) position. Make sure the door is closed tightly .

## **Water Filtration System**

Do not use with water that is microbiologically unsafe or of unknown quality without adequate disinfection before or after the system. Systems certified for cyst reduction may be used on disinfected waters that may contain filterable cysts.

### **Water Filter Status Light (on some models)**

The filter status light will help you know when to change your water filter. this is located in the refrigerator control panel.

- The light will turn on red. This tells you that it is almost time to change the filter.
- It is recommended that you replace the filter when the status light changes to red OR water flow to your water dispenser or ice maker decreases noticeably.

**NOTE:** The filter should be replaced at least every 6 months depending on your water quality and usage.

### **Resetting the Filter Status**

- The reset button is located on the control panel in the refrigerator compartment. To reset the status light after changing the filter, press the button TEMP SETTING within 3 seconds. The status light will change from red to off when the system is reset.

### **Changing the Water Filter**

#### **Style 1**

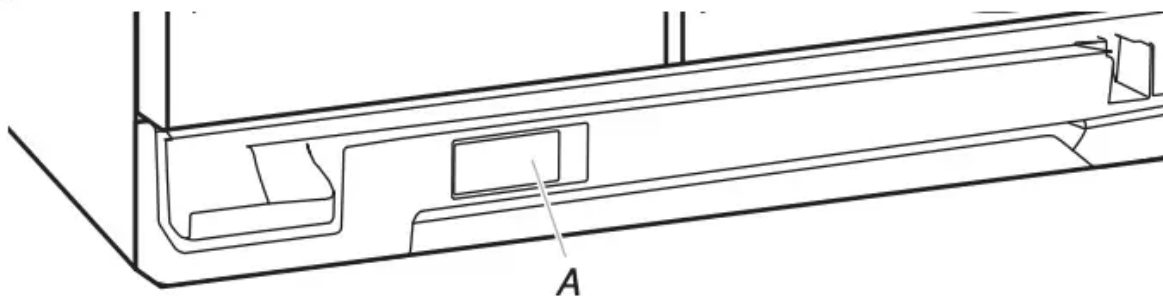

#### **A. Water filter cover door**

1. Locate the water filter cover door in the base grille, and pull open the filter door. The filter will be released and then be ejected as the door is opened.
2. When the door is completely open, pull the filter straight out.

**NOTE:** There may be some water in the filter. Some spilling may occur. Use a towel to wipe up any spills.

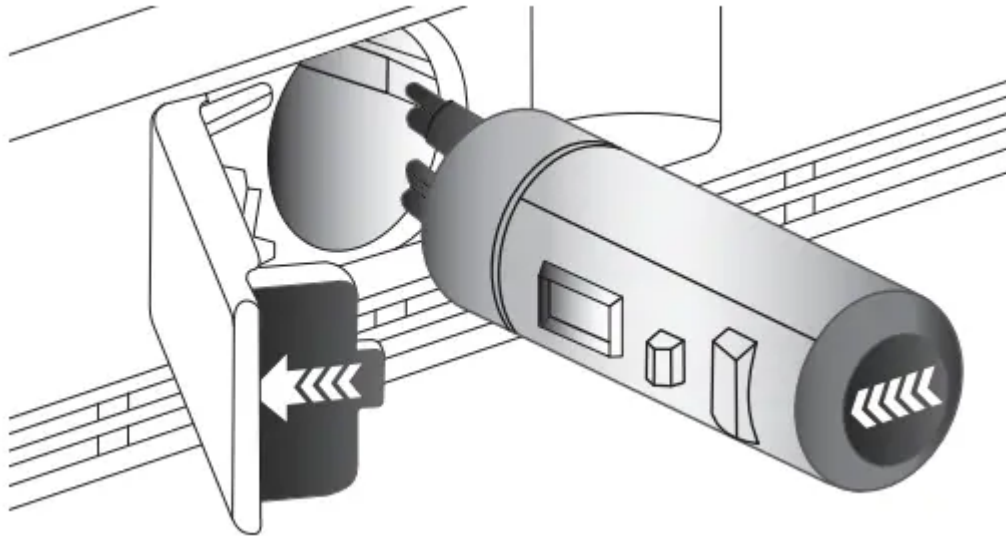

3. Take the new filter out of its packaging and remove the covers from the O-rings. Be sure the O-rings are still in place after the covers are removed.
4. With the arrow pointing to the left (toward the filter cover door's hinge), align the new filter with the filter housing and slide it into place. The filter cover door will automatically begin to close as the new filter is inserted.
5. Close the filter cover door completely in order to snap the filter into place. You may need to press hard.
6. Flush the water system. See "Water and Ice Dispensers."

### Style 2

1. Locate the water filter cover door in the base grille, and pull open the filter door.

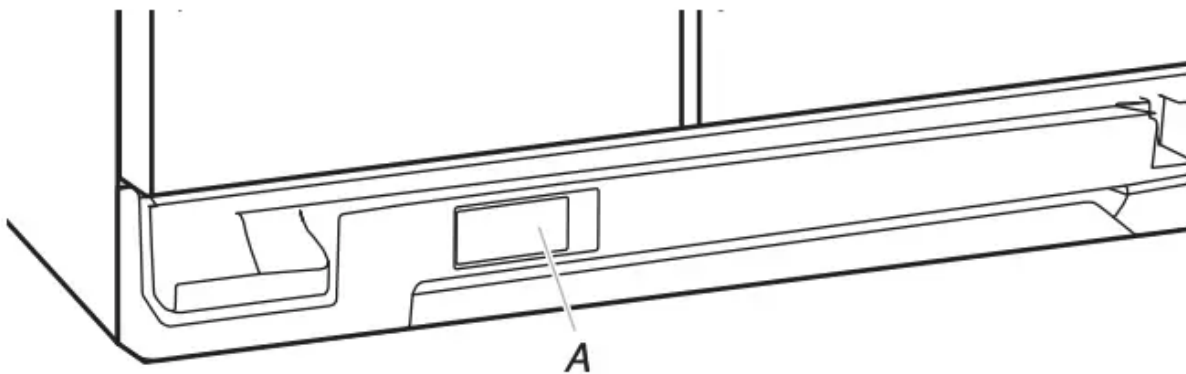

*A. Water filter cover door*

2. Twist the water filter and turn 90° counterclockwise to unlock

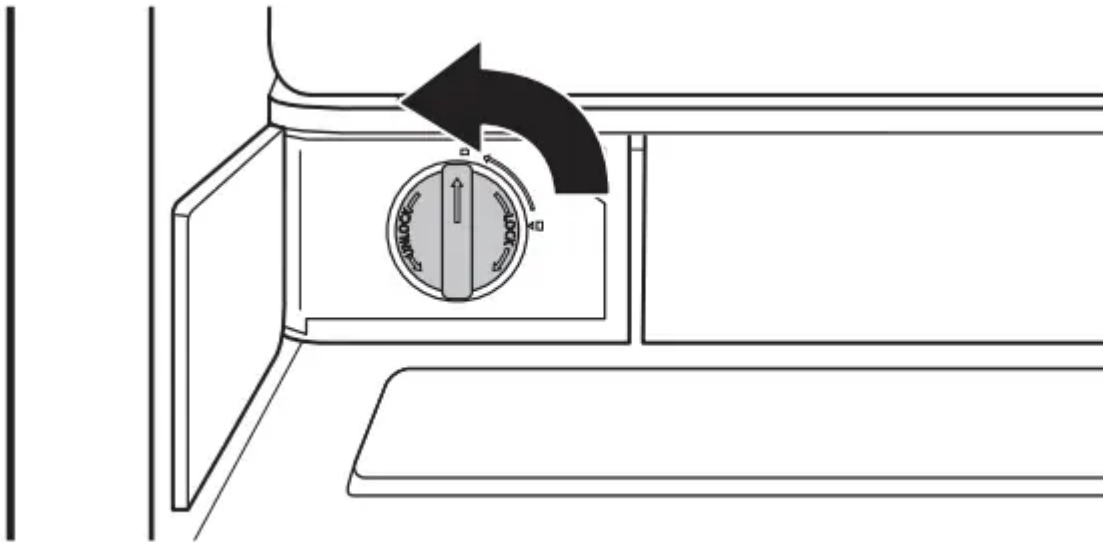

3. Pull the filter out of the housing.

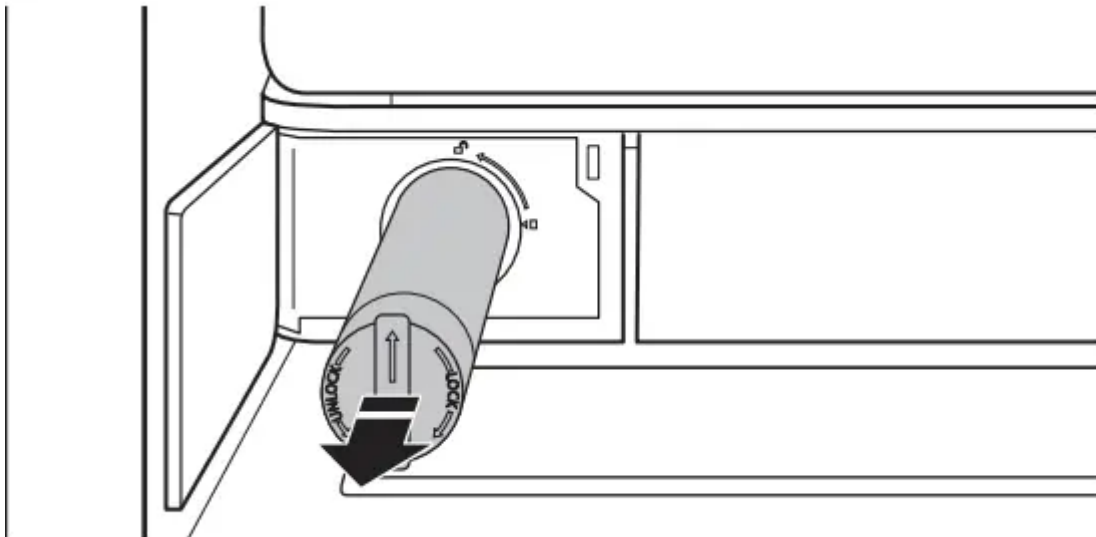

4. Remove the water filter cap from the water filter.

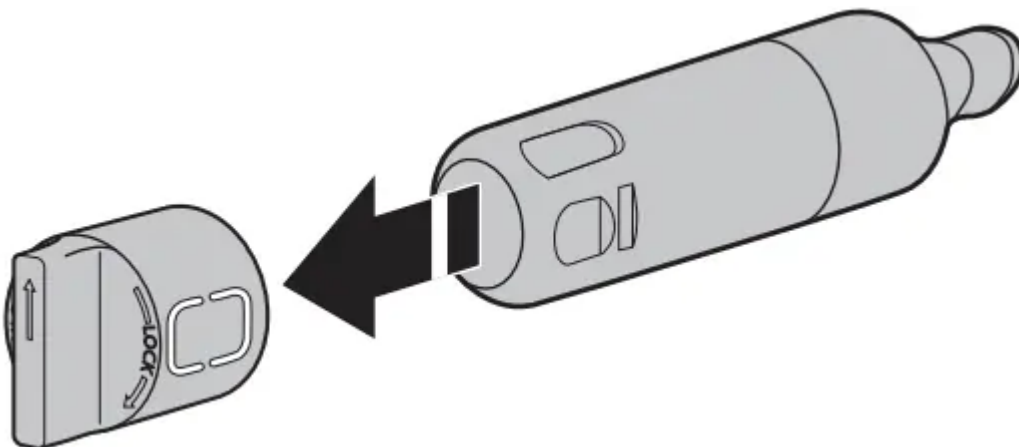

5. Install the water filter cap onto the new filter. Be sure to align the arrows so the grooves in the filter align with the ribs in the filter cap.

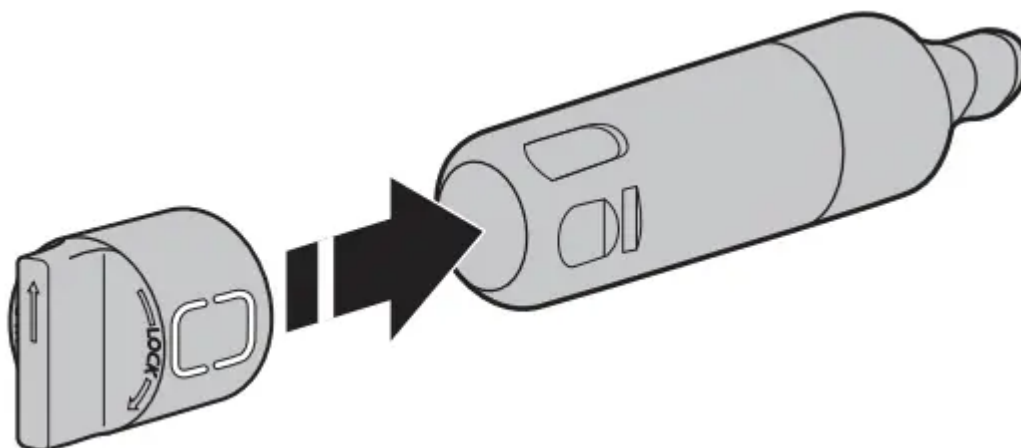

6. Insert the filter into the housing.

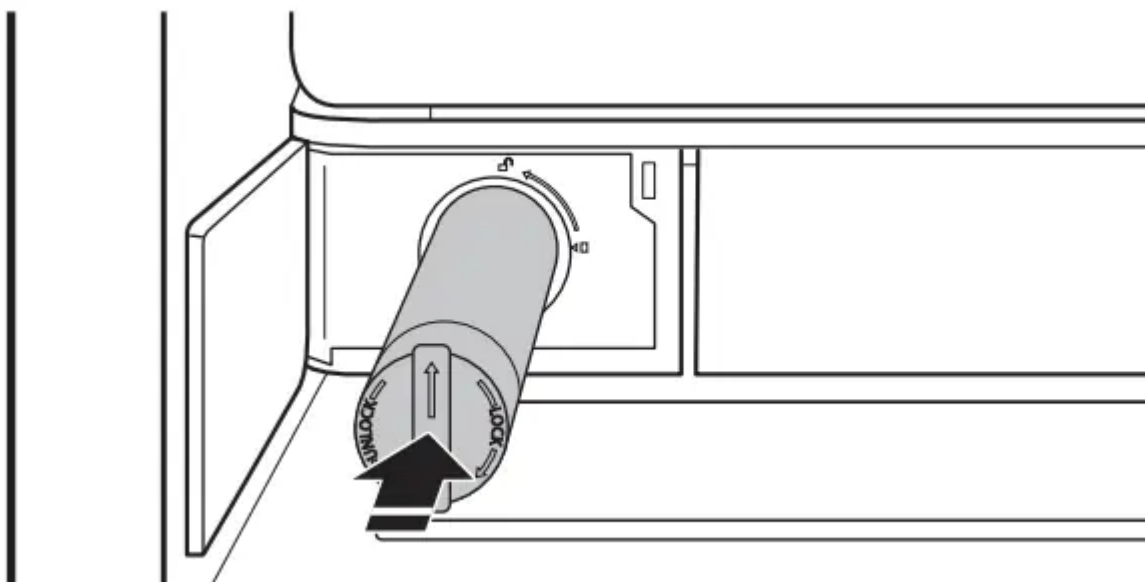

7. Twist the water filter and turn 90° clockwise until it locks into place and that arrows are aligned.

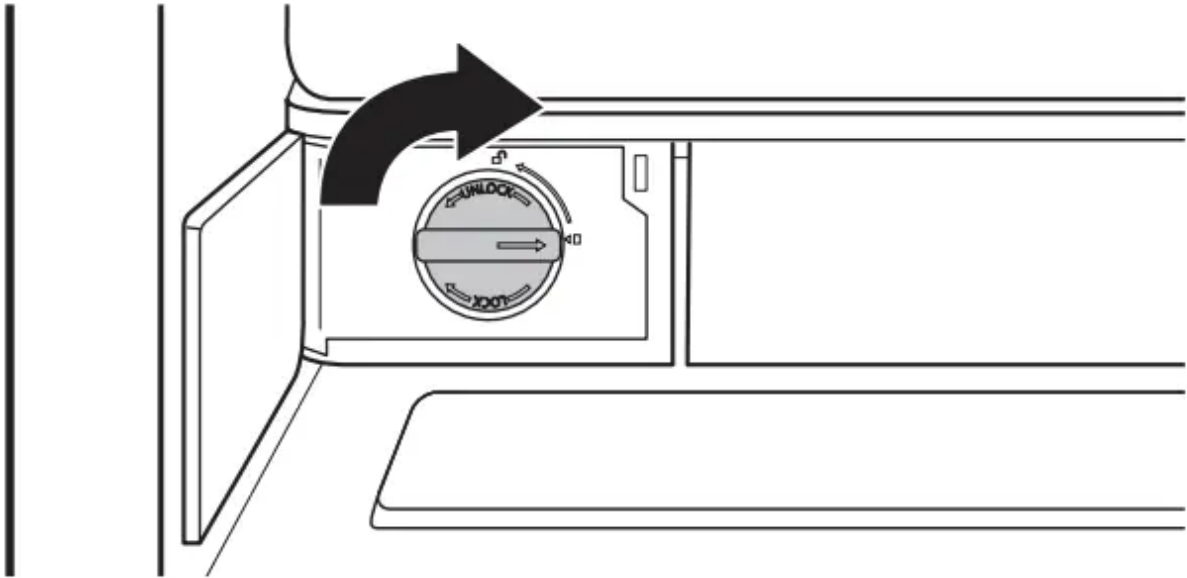

8. Push the water filter door closed.

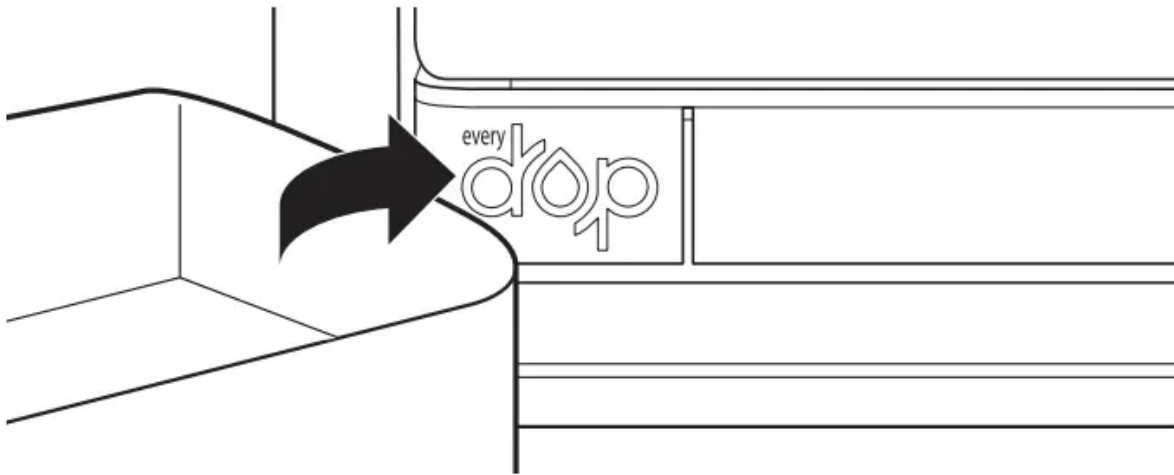

## TROUBLESHOOTING

For recommendations that may help you avoid a service call, or visit [www.whirlpool.com/product\\_help](http://www.whirlpool.com/product_help). For a complete Troubleshooting listing with more information about additional topics, see the Installation Instructions and Owner's Manual provided with your refrigerator, or visit our website and download the User Instructions for your model.

### **⚠️ WARNING**

**Electrical Shock Hazard** Plug into a grounded 3 prong outlet. Do not remove ground prong. Do not use an adapter. Do not use an extension cord. Failure to follow these instructions can result in death, fire, or electrical shock.

PROBLEM	Possible Causes and/or Recommended Solutions
Refrigerator will not operate	<ul style="list-style-type: none"> <li>■ <b>Not connected to an electrical supply</b> - Plug the power cord into a grounded 3 prong outlet. Do not use an extension cord.</li> <li>■ <b>No power to the electrical outlet</b> - Plug in a lamp to see if the outlet is working.</li> <li>■ <b>Household fuse has blown or circuit breaker has tripped</b> - Replace the fuse or reset the circuit breaker. If the problem continues, contact a licensed electrician.</li> <li>■ <b>New installation</b> - Following installation, allow 24 hours for the refrigerator and freezer to cool completely.</li> </ul> <p><b>NOTE:</b> Adjusting the temperature control(s) to the coldest setting will not cool either compartment (refrigerator or freezer) more quickly.</p>
Refrigerator seems noisy	<p>The compressor in your new refrigerator regulates temperature more efficiently and uses less energy than older models. During various stages of operation, you may hear normal operating sounds that are unfamiliar.</p> <p><b>The following noises are normal:</b></p> <ul style="list-style-type: none"> <li>■ <b>Buzzing/Clicking</b> - Heard when the water valve opens and closes to dispense water or fill the ice maker. If the refrigerator is connected to a water line, this is normal. If the refrigerator is not connected to a water line, turn off the ice maker.</li> <li>■ <b>Cracking/Crashing</b> - Heard when ice is ejected from the ice maker mold.</li> <li>■ <b>Popping</b> - Heard when the inside walls contract/expand, especially during initial cooldown.</li> <li>■ <b>Pulsating/Whirring</b> - Heard when the fans/compressor adjust to optimize performance during normal operation.</li> <li>■ <b>Rattling</b> - Heard when water passes through the water line, or due to the flow of refrigerant. Rattling may also come from items placed on top of the refrigerator.</li> <li>■ <b>Water running or gurgling</b> - Heard when ice melts during the defrost cycle and water runs into the drain pan.</li> <li>■ <b>Sizzling</b> - Heard when water drips onto the heater during the defrost cycle.</li> </ul>
Motor seems to run too much	<ul style="list-style-type: none"> <li>■ <b>Your new refrigerator has an energy-efficient motor</b> - The refrigerator may run longer than you're used to, because the compressor and fans operate at lower speeds that are more energy-efficient. This is normal.</li> </ul> <p><b>NOTE:</b> Your refrigerator may run even longer if the room is warm, a large load of food is added, the doors are opened often, or if a door has been left open.</p>
Temperature is too warm	<ul style="list-style-type: none"> <li>■ <b>New installation</b> - Following installation, allow 24 hours for the refrigerator and freezer to cool completely.</li> </ul> <p><b>NOTE:</b> Adjusting the temperature control(s) to the coldest setting will not cool either compartment (refrigerator or freezer) more quickly.</p> <ul style="list-style-type: none"> <li>■ <b>Doors are opened often or not closed completely</b> - This allows warm air to enter the refrigerator. Minimize door openings, keep the doors fully closed, and make sure both doors are properly sealed.</li> <li>■ <b>Air vents are blocked</b> - Remove items that are immediately in front of the vents.</li> <li>■ <b>Large amount of warm food recently added</b> - Allow several hours for the refrigerator to return to its normal temperature.</li> <li>■ <b>Controls are not set correctly for the surrounding conditions</b> - Adjust the controls to a colder setting. Check the temperature again in 24 hours.</li> </ul>
Temperature is too cold	<ul style="list-style-type: none"> <li>■ <b>Controls are not set correctly for the surrounding conditions</b> - Adjust the controls to a warmer setting. Check the temperature again in 24 hours.</li> <li>■ <b>Top refrigerator shelf is colder than lower shelves</b> - On some models, air from the freezer enters the refrigerator compartment through vents near the top refrigerator shelf. As a result, the top shelf can be slightly colder than lower shelves.</li> <li>■ <b>Air vents are blocked</b> - Remove items that are immediately in front of the vents.</li> </ul>
Interior moisture buildup	<p><b>NOTE:</b> Some moisture buildup is normal. Clean with a soft dry cloth.</p> <ul style="list-style-type: none"> <li>■ <b>Room is humid</b> - A humid environment contributes to moisture buildup. Only use the refrigerator in an indoor location, with as little humidity as possible.</li> <li>■ <b>Doors are opened often or not closed completely</b> - This allows humid air to enter the refrigerator. Minimize door openings, keep the doors fully closed, and make sure both doors are properly sealed.</li> </ul>

## WHIRLPOOL® MAJOR APPLIANCE LIMITED WARRANTY

ATTACH YOUR RECEIPT HERE. PROOF OF PURCHASE IS REQUIRED TO OBTAIN WARRANTY SERVICE. Please have the following information available when you call the Customer eXperience Center:

- Name, address, and telephone number
- Model number and serial number
- A clear, detailed description of the problem
- Proof of purchase, including dealer or retailer name and address

### IF YOU NEED SERVICE:

1. Before contacting us to arrange service, please determine whether your product requires repair. Some questions can be addressed without service.

2. All warranty service is provided exclusively by our authorized Whirlpool Service Providers. In the U.S. and Canada, direct all requests for warranty service to: Whirlpool Customer eXperience Center In the U.S.A., call 1-800-253-1301. In Canada, call 1-800-807-6777. If outside the 50 United States or Canada, contact your authorized Whirlpool dealer to determine whether another warranty applies

## **ONE YEAR LIMITED WARRANTY**

### WHAT IS COVERED

For one year from the date of purchase, when this major appliance is installed, operated, and maintained according to instructions attached to or furnished with the product, Whirlpool Corporation or Whirlpool Canada LP (hereafter "Whirlpool") will pay for factory specified replacement parts and repair labor to correct defects in materials or workmanship that existed when this major appliance was purchased or, at its sole discretion, replace the product. In the event of product replacement, your appliance will be warranted for the remaining term of the original unit's warranty period.

YOUR SOLE AND EXCLUSIVE REMEDY UNDER THIS LIMITED WARRANTY SHALL BE PRODUCT REPAIR AS PROVIDED HEREIN. Service must be provided by a Whirlpool designated service company. This limited warranty is valid only in the United States or Canada and applies only when the major appliance is used in the country in which it was purchased. This limited warranty is effective from the date of original consumer purchase. Proof of original purchase date is required to obtain service under this limited warranty.

### WHAT IS NOT COVERED

1. Commercial, non-residential, multiple-family use, or use inconsistent with published user, operator, or installation instructions.
2. In-home instruction on how to use your product.
3. Service to correct improper product maintenance or installation, installation not in accordance with electrical or plumbing codes, or correction of household electrical or plumbing (e.g., house wiring, fuses, or water inlet hoses).
4. Consumable parts (e.g., light bulbs, batteries, air or water filters, preservation solutions).
5. Defects or damage caused by the use of non-genuine Whirlpool parts or accessories.
6. Conversion of products from natural gas or propane gas.
7. Damage from accident, misuse, abuse, fire, floods, acts of God, or use with products not approved by Whirlpool.
8. Repairs to parts or systems to correct product damage or defects caused by unauthorized service, alteration, or modification of the appliance.

9. Cosmetic damage including scratches, dents, chips, and other damage to the appliance finishes, unless such damage results from defects in materials and workmanship and is reported to Whirlpool within 30 days.
10. Discoloration, rust, or oxidation of surfaces resulting from caustic or corrosive environments including, but not limited to, high salt concentrations, high moisture or humidity, or exposure to chemicals.
11. Food or medicine loss due to product failure.
12. Pickup or delivery. This product is intended for in-home repair.
13. Travel or transportation expenses for service in remote locations where an authorized Whirlpool servicer is not available.
14. Removal or reinstallation of inaccessible appliances or built-in fixtures (e.g., trim, decorative panels, flooring, cabinetry, islands, countertops, drywall) that interfere with servicing, removal, or replacement of the product.
15. Service or parts for appliances with original model/serial numbers removed, altered, or not easily determined.

The cost of repair or replacement under these excluded circumstances shall be borne by the customer.

#### **DISCLAIMER OF IMPLIED WARRANTIES**

IMPLIED WARRANTIES, INCLUDING ANY IMPLIED WARRANTY OF MERCHANTABILITY OR IMPLIED WARRANTY OF FITNESS FOR A PARTICULAR PURPOSE, ARE LIMITED TO ONE YEAR OR THE SHORTEST PERIOD ALLOWED BY LAW. Some states and provinces do not allow limitations on the duration of implied warranties of merchantability or fitness, so this limitation may not apply to you. This warranty gives you specific legal rights, and you also may have other rights that vary from state to state or province to province.

#### **DISCLAIMER OF REPRESENTATIONS OUTSIDE OF WARRANTY**

Whirlpool makes no representations about the quality, durability, or need for service or repair of this major appliance other than the representations contained in this warranty. If you want a longer or more comprehensive warranty than the limited warranty that comes with this major appliance, you should ask Whirlpool or your retailer about buying an extended warranty.

#### **LIMITATION OF REMEDIES: EXCLUSION OF INCIDENTAL AND CONSEQUENTIAL DAMAGES**

YOUR SOLE AND EXCLUSIVE REMEDY UNDER THIS LIMITED WARRANTY SHALL BE PRODUCT REPAIR AS PROVIDED HEREIN. WHIRLPOOL SHALL NOT BE LIABLE FOR INCIDENTAL OR CONSEQUENTIAL DAMAGES. Some states and provinces do not allow the exclusion or limitation of incidental or consequential damages, so these limitations and exclusions

may not apply to you. This warranty gives you specific legal rights, and you also may have other rights that vary from state to state or province to province.

**Warning**

This content is compiled from multiple sources and is provided for reference purposes only. It may not be complete or fully applicable to all situations. If you are unable to resolve your issue, please contact the product manufacturer or an authorized service provider for official support.

---

Document generated by [ManualsFile](#)

