

USER TIPS

What is Evaporative Cooling?

Honeywell Evaporative Air Coolers are built to maximize energy efficiency and keep energy costs low. Warm air is drawn into the cooler and enters the Honeycomb Cooling Media. Water pumped from the water tank pours over the Honeycomb Cooling Media. As the warm air passes through the Honeycomb Cooling Media, the water absorbs the heat, naturally cooling and humidifying the air. A fan propels the cooled air out into the room. This no-compressor system cools naturally, efficiently and inexpensively

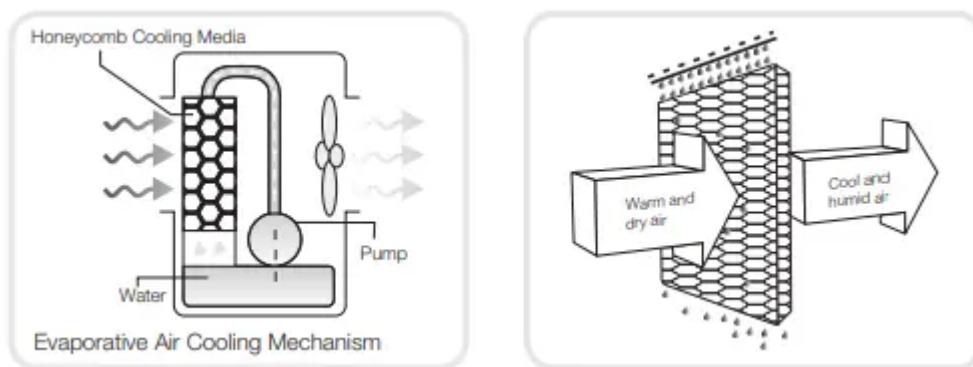

The recommended maximum relative humidity level is 60% or less, which allows a noticeable temperature decrease. The temperature will be lower in drier climates because higher evaporation occurs when the humidity is low.

NOTE

When the product is used for the first time the Honeycomb Cooling Media will have an odor which will dissipate in a few hours or so of initial use.

COOLER LOCATION

To maximize efficiency, position the Air Cooler according to the following guidelines:

Indoors

Place the cooler in front of an open door or window. Ensure that there is adequate cross-ventilation in the room by leaving a door or window open opposite the cooler.

The Evaporative Air Cooler should not be used in enclosed spaces. It must be kept level and there must be water in the water tank. Doors and windows should be opened to allow free air flow. The Evaporative Air Cooler works best when placed near an open window, so that outside air is drawn into the Evaporative Air Cooler, circulates in the room, then exits via the door. The maximum cooling effect is felt when a person is near the flow of air coming out of

the Evaporative Air Cooler. The Evaporative Air Cooler produces moisture and can be used to humidify dry air. To be used for humidification the windows and doors should be closed.

IMPORTANT: The evaporative air cooler is not an air conditioner as it does not use a compressor or refrigerant gas. It should not be expected to cool as efficiently as a refrigerated air conditioner.

Outdoors (for outdoor models only)

- Use only on GFCI Protected outlets/ sockets (for USA only).
- Power cords must be secured to avoid tripping.
- The wiring and connections must be protected from water. The electrical plug and Air Cooler When used outdoors, insert the air cooler electrical plug into an IP44 compliant outdoor electrical outlet.
- Set the unit on a solid flat surface

IMPORTANT: Honeywell Outdoor Air Cooler models are designed to IPX4 product standards and not recommended to be placed outdoors during heavy rain or snow.

SAFETY RULES

WARNING - READ AND SAVE THE AIR COOLER GUIDE AND USER MANUAL

The Air Cooler Guide and User Manual are intended to provide important information needed to set up, operate, maintain and troubleshoot your Air Cooler. Failure to follow these instructions may damage and/or impair its operation, create hazards, and void the warranty

READ AND SAVE THESE INSTRUCTIONS:

When using electrical appliances, basic safety precautions should always be followed:

- Check the household voltage to ensure it matches the appliance's rating specifications.
- Before operating the product, remove the packaging and check that product is in good condition.
- DO NOT operate with a damaged cord or plug. If the supply cord is damaged, it must be replaced with a supply cord which is as per manufacturers specifications, by the authorized service centre or its service agent or a similarly qualified person in order to avoid a hazard.
- DO NOT use an extension cord with this unit.
- DO NOT run power cord under carpeting, or cover it with rugs or runners. Keep the cord away from areas where it may be tripped over.
- Always ensure the water tank is filled with water above the "min." level mark, when operating the air cooler in evaporative COOLING mode.
- Always unplug the Air Cooler before refilling the water tank, cleaning, servicing or relocating the unit.

- Never pull the cord. Remove it from the electrical outlet/ socket by grasping and pulling on the plug-end of the cord.
- This appliance has been manufactured for use in domestic environments and must not be used for other purposes.
- DO NOT use in areas where gasoline, paint or other flammable goods and objects are stored.
- When using the COOL setting, make sure the water tank is at Max Indicator Level. Operating the unit on the COOL setting with an empty tank may result in damage to the water pump.
- DO NOT attempt to repair or adjust any electrical or mechanical functions of the Air Cooler, as this may void the warranty.
- DO NOT cover the cooler's air inlet or outlet, as this may damage the motor.
- DO NOT insert or allow objects to enter any ventilation or exhaust opening, as this may damage the unit and may cause electrical shock or fire.
- DO NOT operate with the Honeycomb Cooling Media removed, as this will overload and damage the motor
- DO NOT leave the operating appliance unattended for an extended period of time.
- DO NOT allow children to play with this appliance, packaging or plastic bags.
- DO NOT continue to operate the unit if it is damaged or if it malfunctions. Refer to the TROUBLESHOOTING section and contact the CUSTOMER SUPPORT CENTER.
- Always place the unit on a dry level floor.
- DO NOT use in bathrooms or near water. DO NOT keep the product where it may fall into a water container.
- Store in a dry area when not in use.
- This appliance is not intended for use by persons (including children or elderly) with reduced physical, sensory or mental capabilities, or lack of experience and knowledge, unless they have been given supervision or instructions concerning the use of the appliance by a person responsible for their safety.
- Always grip the side handles to move the Air Cooler.
- **WARNING:** To reduce the risk of fire or electric shock, do not use this appliance with any solid state speed control device.

STORAGE AND MAINTENANCE GUIDELINES

Read the detailed CLEANING & DRAINING THE WATER TANK instructions for your Air Cooler, located in the separate User Manual. Below is a general guideline for maintenance and storage of your Air Cooler.

WARNING: Always switch OFF the Air Cooler and unplug it from the electrical source before cleaning or maintenance.

Cleaning

At least once a week, drain the water tank completely and refill with fresh water. Doing this will greatly reduce mineral deposits and help to extend the life of the Honeycomb Cooling Media.

End of Season Storage

If the Air Cooler will not be used for a long time:

- Make sure all parts are dry by running the Fan Only mode for about 30 minutes before storing (time depends on ambient humidity conditions).
- Switch OFF the Air Cooler and unplug from the power supply
- Empty/drain all the water from the tank. Note: If the unit is connected to a continuous water supply, you must switch off the water supply and remove the drain tube before draining the water tank. This function is only available on some Honeywell Air Cooler models. Check the User Manual to see if your unit has the Continuous Water Supply Function.
- Clean the water tank with a damp cloth to wipe away any dust or mineral deposits
- Remove the Honeycomb Cooling Media and Carbon Dust Filter* from the Air Cooler and rinse under fresh water to remove dust and dirt.
- Replace the Honeycomb Cooling Media and Carbon Dust Filter* after they are clean and dry.
- To protect the unit from dust and scratches, cover with a clean cloth or plastic bag before storing.
- Coil the power cord and store it away from the floor to protect it.

TROUBLESHOOTING GUIDE

Customer Service Center: See the last page of the User Manual to find the contact details for the Customer Service Center for your area.

No discharge of air.

- Cord is not plugged in. -> Make sure power cord is plugged in and the switch is ON.
- Power is not ON -> Turn the unit ON by pressing the power button on the control panel or remote control.

Not Cooling / Unit is making noise.

- Pump is not turned ON -> Turn on COOL function from remote or control panel.

- Low or no water in tank, when COOL is selected -> Refill water tank.
- Damaged Pump or Calcium deposits on blower. -> Contact Customer Service Center.

Excessive humidity in the room.

In cooling mode, the Air Cooler produces moisture as a result of evaporative cooling. This is normal.

- The Air Cooler cools best in dry climates. If the ambient humidity level is high (60% or above), refrain from using the Air Cooler until ambient humidity is reduced.
- Make sure the window/doors are open and there is adequate cross-ventilation in the room so that the moisturized air can circulate better. Do not use the evaporative cooling function on days with high ambient humidity.

Odors.

- When the Cooler is new -> When the unit is used for the first time, the Honeycomb Cooling Media will have an odor, which will dissipate within a few hours of initial use.
- Algae or mold due to moist parts. In very damp conditions, algae may form. -> Check the Honeycomb Cooling Media. If you see mold spots on the media or suspect an algae issue, remove and replace the Honeycomb Cooling Media. Contact the Customer Service Center for more information. / Check water tank & other cooler parts. If you see mold spots or suspect an algae issue, use a damp cloth to wipe away the algae until all spots have disappeared. Make sure all parts are clean & dry before storage. Contact the Customer Service Center if problem persists.

Remote control does not work.

- Remote control batteries are old & used or inserted incorrectly in the battery compartment. -> Replace with new batteries. Follow the polarity guide inside the battery compartment.
- Damaged remote control. -> If replacing new batteries in the correct position does not work, contact the Customer Service Center.

The unit does not respond.

- Damaged Control Panel on unit. -> Try to activate the unit with the Remote Control. If the unit responds, then the Control Panel on the unit may be experiencing problems - contact the Customer Service Center / If neither the Remote Control or the Control Panel is working, contact the Customer Service Center

The outdoor Air Cooler is wet from rain.

- The Air Cooler was placed outdoors (this is only allowed for outdoor Air Cooler models) and soaked by heavy rain. -> A small amount of rain on the unit is not a problem as long as the electrical plug and outlet are dry. If they are wet, DO NOT touch the unit or electrical plug/outlet. Switch off the master power for the outlet before unplugging the

unit from the electrical outlet. Make sure all outlets and plugs are dry before use. / The Air Cooler is designed to IPX4 product standards and not recommended to be placed outdoors during heavy rain conditions. Do not operate the Air Cooler when wet. Wait for the Air Cooler to dry before plugging in and turning on the unit again.

PARTS DESCRIPTION

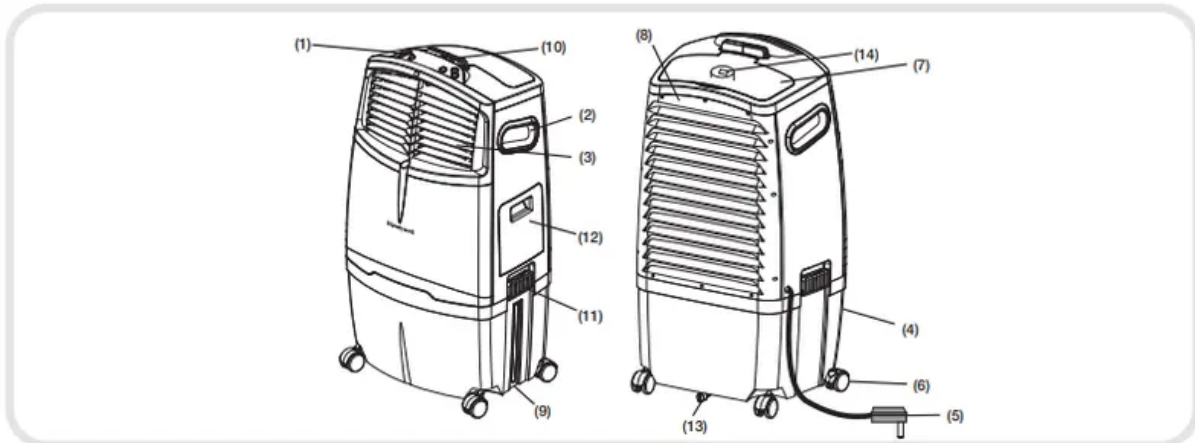

1) Control Panel

2) Handle

3) Louvers

4) Water Tank

5) Power Cord & Plug

6) Casters

7) Ice Compartment Lid

8) Rear Grill

9) Water Level Indicator

10) Remote Control

11) Detachable Water Tank Latch

12) Water Fill Door

13) Drain Plug

14) Water Regulator

WARNING -- READ AND SAVE THE AIR COOLER SAFETY & MAINTENANCE GUIDE AND USER MANUAL BEFORE USING THIS PRODUCT. FAILURE TO FOLLOW THESE INSTRUCTIONS MAY DAMAGE AND/ OR IMPAIR ITS OPERATION AND VOID THE WARRANTY.

USE & OPERATION

CONTROL PANEL



Icons on Display Screen

- | | |
|-------------------------|------------|
| Low water level in tank | High speed |
| Cool | Swing |
| Fan speed | Timer |
| Low speed | Natural |
| Medium speed | |

FUNCTION BUTTONS

POWER

Press the button to turn the unit on. The cooler will start automatically at medium speed. After a few seconds the speed will switch to low. To turn the unit off, press the button again.

SPEED

Press the SPEED button repeatedly to change the speed between High - Medium - Low. The indicator light will show the selected speed:



COOL

Press the COOL button until is illuminated on the display screen. This activates evaporative cooling. The water pump will operate and you will feel the cooler air after the Honeycomb Cooling Media is completely wet. When the is not illuminated on the display screen, the unit switches to a fan only mode, without evaporative cooling.

TIMER

Press the TIMER button until the desired time duration setting is selected. When the set time has passed, the unit will automatically turn off (unit remains in Standby mode until power cord is unplugged from electrical socket). The TIMER function allows you to program the unit for up to 7.5 hours of use.

SWING

Press the SWING button until is illuminated on the display screen. The louvers will begin to move left to right automatically. Vertical Air Flow - You can manually adjust the louvers to change vertical air flow.

NATURAL

Press the NATURAL button until is illuminated on the display screen. The fan will randomly change between High, Medium and Low speeds to mimic a natural breeze.

ROOM COOLING AND HUMIDIFYING

In cooling mode, Honeywell Air Coolers provide cool, moist air through the evaporation of water. There is a manual Water Regulator knob located in the ice compartment of the unit. This allows you to adjust the amount of water pumped over the Honeycomb Cooling Media, thus helping to control cooling and humidification levels.

When the Water Regulator is set to MIN, the water pump distributes a minimal amount of water to the Honeycomb Cooling Media. This results in less water evaporation and reduces the cooling effect.

When the Water Regulator is set to MAX, the water pump distributes the maximum amount of water to the Honeycomb Cooling Media. This results in maximum water evaporation and greater cooling performance

REMOTE CONTROL



POWER : ON / OFF
SPEED : Low / Medium / High
COOL : Controls cooling or fan option
SWING : Controls the motion of the louvers
TIMER : Controls the Timer function for automatic off
NATURAL : Turns on Natural mode

Note:

- The remote control requires AAA (2 x 1.5V) batteries for replacement.
- Open the battery compartment at the back of the remote control and insert the batteries inside. Care must be taken to insert the batteries according to the correct polarity (+ / -) markings shown inside the battery compartment.
- Always point the remote control signal transmitter towards the unit when operating. Make sure that the signal path is not obstructed.
- Remove the batteries if the unit is not going to be used for an extended period of time.
- Do not drop the remote control.
- Do not mix different types of batteries such as alkaline, carbon-zinc, or rechargeable batteries.
- Do not mix old and new batteries.
- Do not recharge the battery
- Exhausted batteries are to be removed from the product and safely disposed of as per local regulations
- Do not dispose of batteries in fire. Batteries may explode or leak

WARNING: Caution for ingestion of the small battery. Keep away from children and animals.

COOLER LOCATION

Make sure to position the air cooler correctly before you set up and start using the product. Please refer to the COOLER LOCATION section of the separate Safety & Maintenance Guide.

FILLING WITH WATER

CAUTION: Unplug the unit from the electrical power outlet before emptying or refilling the water tank

Open the Water Fill Door located on the side of the unit.

The Water Level Indicator is located at the side of the unit. Refill the water tank when water level is low. Do not fill water above the "Max." water level mark to avoid water droplets collecting on the louvers. Check the water level in the tank before running the COOL function. Make sure that the water in the tank is above the minimum water level mark. Running the unit in COOL mode with inadequate water may cause pump failure.

Note: The water capacity refers to the total volume of water that can be contained within the air cooler water tank and water distribution system. The water capacity in the tank at the "Max." indicator level may be lower than the actual water capacity of the air cooler.

Note: If ice is available, you may add ice in the top ice compartment to enhance the cooling performance.

LOW WATER ALARM

The unit is equipped with a low water sensor. In Cooling Mode, when water in the tank is below the minimum level, you will hear a beeping sound and the will flash continuously. The unit will automatically pause evaporative cooling.

Refill the water tank to deactivate the alarm in cooling mode. First switch OFF the unit and unplug from the power outlet. Fill the water tank with water above the minimum water level mark. Plug in and switch ON again.

To deactivate the alarm and continue using the unit as a fan (without evaporative cooling), switch the unit OFF and then ON again. The Low Water Alarm will not activate in Fan only mode. The Low Water Alarm will sound again if the COOL function is activated while the water tank is still empty.

If the cooler will not be used for a long period of time, please refer to the STORAGE & MAINTENANCE GUIDELINES located in the separate Safety & Maintenance Guide.

CLEANING THE CARBON DUST FILTER* AND HONEYCOMB COOLING MEDIA

- The appliance is supplied with a Carbon Dust Filter* & Honeycomb Cooling Media
- The Carbon Dust Filter* and Honeycomb Cooling Media are located inside the Rear Grill. See Figure 1 for instructions on how to remove them from the unit for cleaning and maintenance
- Do not run the unit in COOL mode with stale water in the tank. You must empty the water tank and refill with fresh water, especially if the tank has not been cleaned in a long time.
- The cleaning frequency for the Honeycomb media depends on local air and water conditions. In areas where the mineral content of water is high, mineral deposits may build up on the Honeycomb Cooling Media and restrict air flow. Draining the water tank

and refilling with fresh water at least once a week will help reduce mineral deposits. If mineral deposits remain on the Honeycomb Cooling Media, the media should be removed and washed under fresh water. The media should be cleaned every two months or sooner, depending on your needs.

- For best results allow the Honeycomb Cooling Media to dry after each use by turning off the cool function 15 minutes before turning the unit off.

Warning

This content is compiled from multiple sources and is provided for reference purposes only. It may not be complete or fully applicable to all situations. If you are unable to resolve your issue, please contact the product manufacturer or an authorized service provider for official support.