

# Operation Guide

## Parts Location

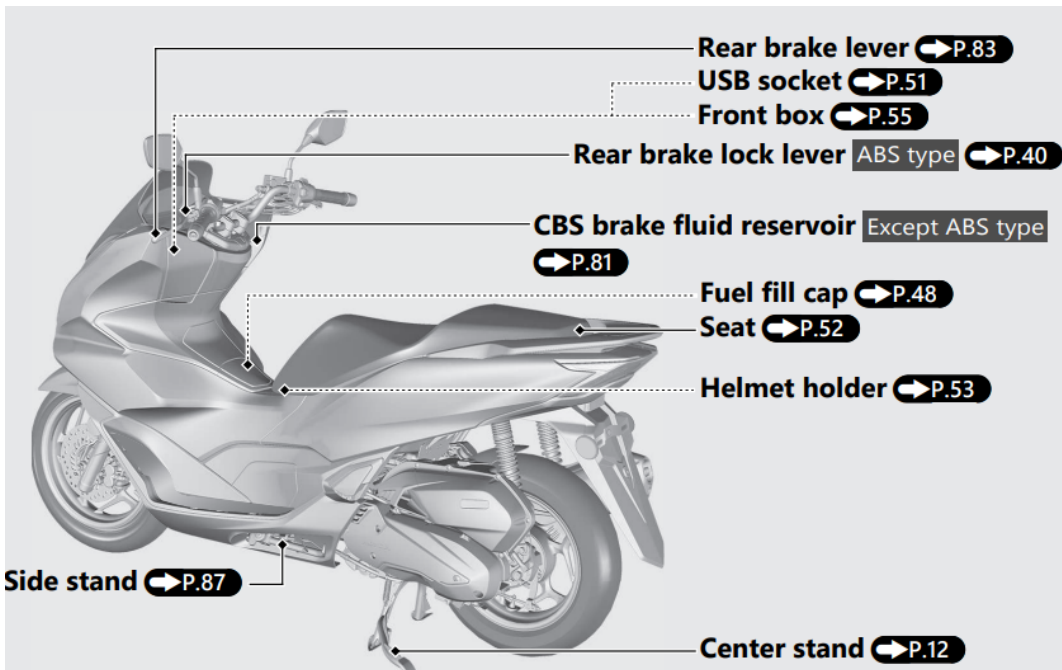

## Instruments

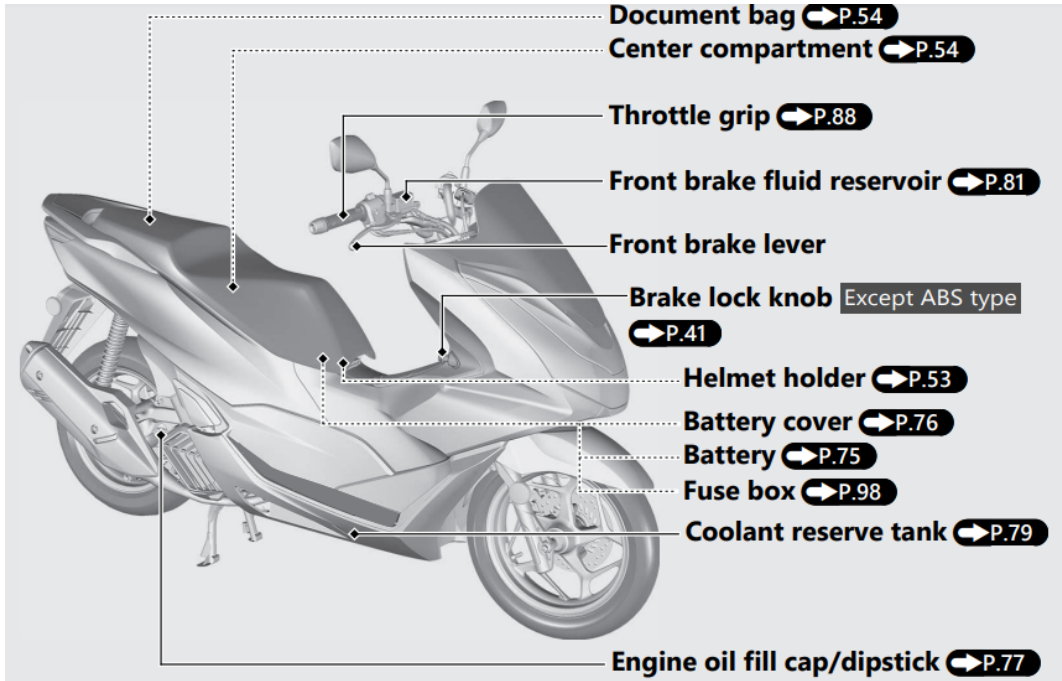



## Display Check

When the ignition switch is turned to the ON position, an initial animation will show. If any part of these displays does not come on when it should, have your dealer check for problems.

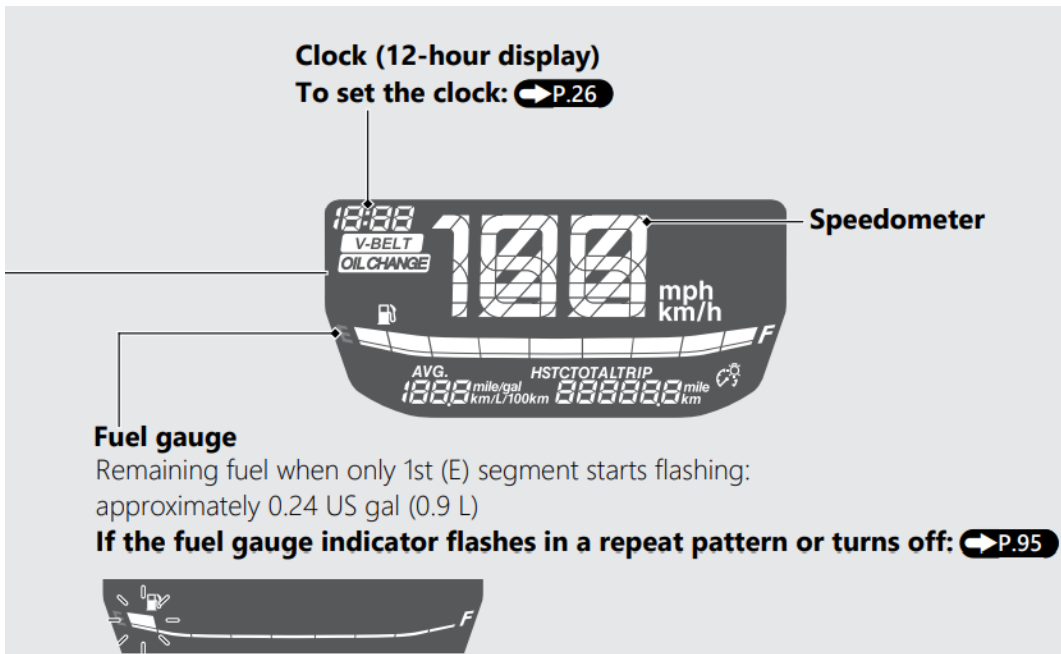



**Odometer [TOTAL], Tripmeter [TRIP], and Torque Control [HSTC]**  
 The **SEL** switch selects the odometer, tripmeter, and Torque Control.

- Odometer:  
Total distance ridden.
- Tripmeter:  
Distance ridden since tripmeter was reset. To reset tripmeter, press and hold the **SET** switch with tripmeter displayed. The average fuel mileage is also reset.
- **ABS type**  
Torque Control :  
Pressing and holding the **SET** switch while Torque Control is displayed turns Torque Control on and off. ➔ P.42

**Average fuel mileage meter [AVG]**  
 The average fuel mileage is based on the tripmeter. Average fuel mileage since tripmeter was reset is displayed. When " - - - " is displayed except after the average fuel mileage has been reset, go to your dealer for service.



**OIL CHANGE indicator**  
 The indicator turns on when the distance traveled reaches the programmed oil change interval. When the oil change indicator appears, reset the indicator after changing the engine oil.

- ▶ The indicator does not go off until it is reset.
- ▶ The oil change indicator appears for the first time when the distance traveled reaches 600 miles (1,000 km).
- ▶ After being reset, the oil change indicator comes on again after another 4,000 miles (6,400 km) are ridden.

If the oil is changed before the oil change indicator comes on, be sure to reset the oil change indicator after changing the oil.

**To reset the oil change indicator:( → P.29)**

You can also check the remaining distance to next interval of the oil change.

**To check the remaining distance:( → P.29)**

## Instruments (Continued)

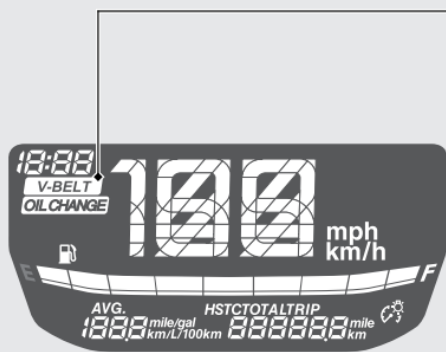

### V-BELT indicator

The indicator turns on when the distance traveled reaches the programmed maintenance interval.

When the V-BELT indicator appears, reset the indicator after performing the periodic maintenance.

- ▶ The indicator does not go off until it is reset.
- ▶ The V-BELT indicator appears for the first time when the distance traveled reaches 8,000 miles (12,000 km).
- ▶ After being reset, the V-BELT indicator comes on again after another 8,000 miles (12,000 km) are ridden.

If the periodic maintenance is performed before the V-BELT indicator comes on, be sure to reset the V-BELT indicator after performing the periodic maintenance.

### To reset the V-BELT indicator:( → P.31)

You can also check the remaining distance to next interval of the maintenance.

### To check the remaining distance:( → P.31)

### Display Setting

The following items can be changed sequentially.

- Clock setting
- Backlight brightness adjustment
- Changing of speed and mileage unit
- Changing of fuel mileage meter unit
- Resetting OIL CHANGE indicator
- Resetting V-BELT indicator



Press and hold the SEL switch and the SET switch



Press the SET switch



Press the SEL switch

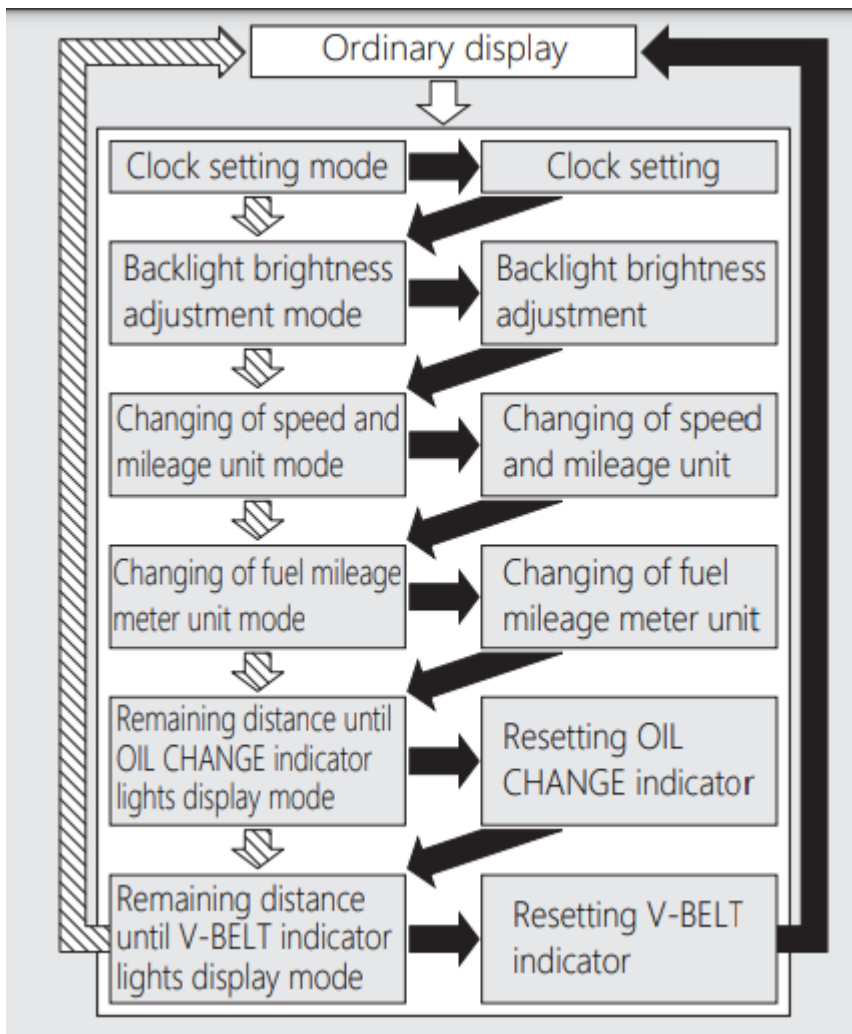

The following moves the ordinary display at display setting.

- The switch is not pressed for about 30 seconds
  - The items that are being set are deleted, and only the items whose settings have been completed are reflected.
- Turn the ignition switch to the OFF position and then to the ON position
  - The items that are being set and the items whose settings have been completed are reflected.

### 1. Clock setting:

1. Turn the ignition switch to the ON position.
2. Pressing and holding the SEL switch and the SET switch makes the hour and minute displays start flashing.
3. Press the SET switch. The hour digits start flashing.
4. Press the SEL switch until the desired hour is displayed.
  - Press and hold to advance the hour fast.



5. Press the SET switch. The minute digits start flashing.



6. Press the SEL switch until the desired minute is displayed.

→ Press and hold to advance the minute fast.



7. Press the SET switch. The clock is set, and then the display moves to the backlight brightness adjustment. (Backlight brightness indicator and backlight brightness adjustment segments start flashing.)

## 2. Backlight brightness adjustment:

You can adjust the brightness to one of five levels

1. Press the SET switch. The backlight brightness indicator and backlight brightness adjustment segments stop flashing.
2. Press the SEL switch. The brightness is switched.

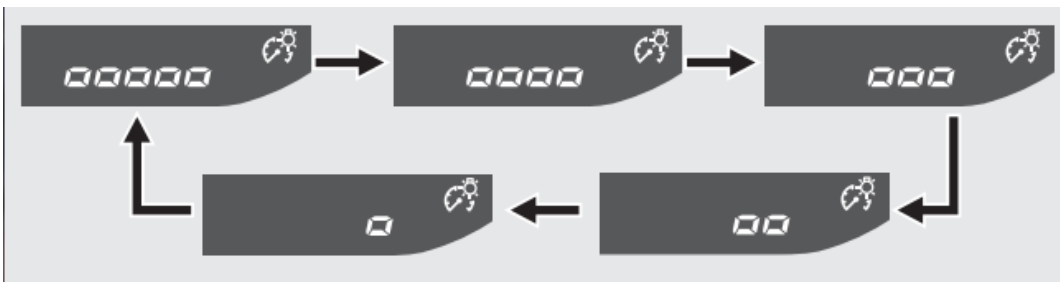

3. Press the SET switch. The backlight is set, and then the display moves to the changing of speed and mileage unit. (Speed and mileage unit start flashing.)

## 3. Changing of speed and mileage unit:

1. Press the SET switch. The speed and mileage unit starts flashing fast.

2. Press the SEL switch to select either “km/h” and “km” or “mph” and “mile”.

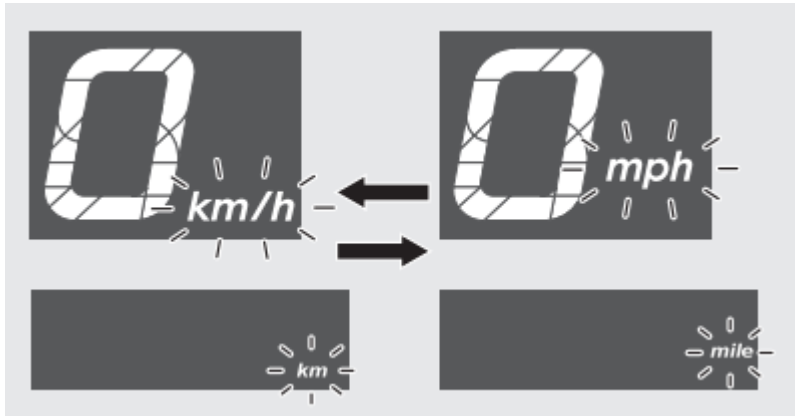

3. Press the SET switch. The speed and mileage unit is set, and then the display moves to the changing of fuel mileage meter unit. (Fuel mileage meter unit start flashing.)

#### 4. Changing the fuel mileage meter unit:

1. Press the SET switch, the fuel mileage meter unit start flashing fast.

2. When the speed and mileage unit selecting “km/h” and “km”.

Press the SEL switch to select “km/L” or “L/100km”.

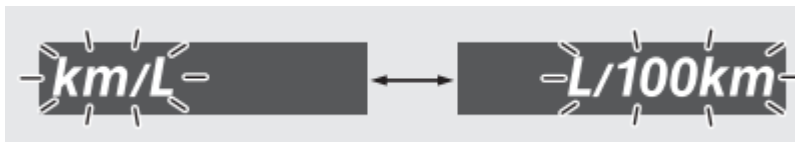

When the speed and mileage unit selecting “mph” and “mile”.

The fuel mileage is indicated by “mile/gal”

3. Press the SET switch. The fuel mileage meter unit is set, and then the display moves to remaining distance until OIL CHANGE indicator lights. (OIL CHANGE indicator starts flashing.)

#### 5. Remaining distance until OIL CHANGE indicator lights display:

##### Confirming the remaining distance until OIL CHANGE indicator lights

Display the remaining distance until the OIL CHANGE indicator lights.

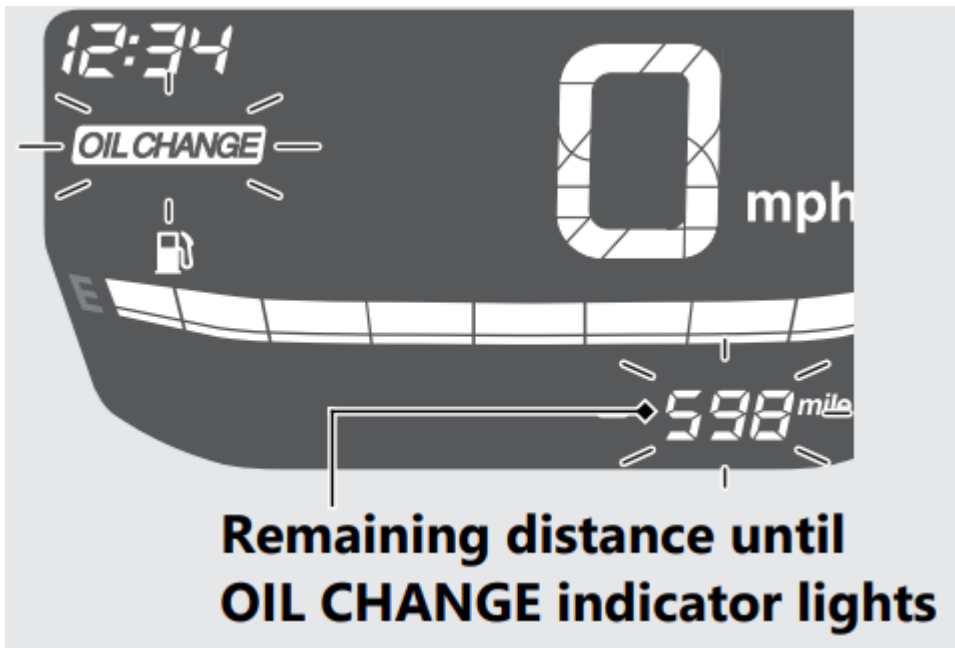

#### Resetting OIL CHANGE indicator

1. Press the SET switch. The OIL CHANGE indicator and the remaining distance until the OIL CHANGE indicator lights flash.

→ "P" flashes when the remaining distance until the OIL CHANGE indicator lights is displayed.

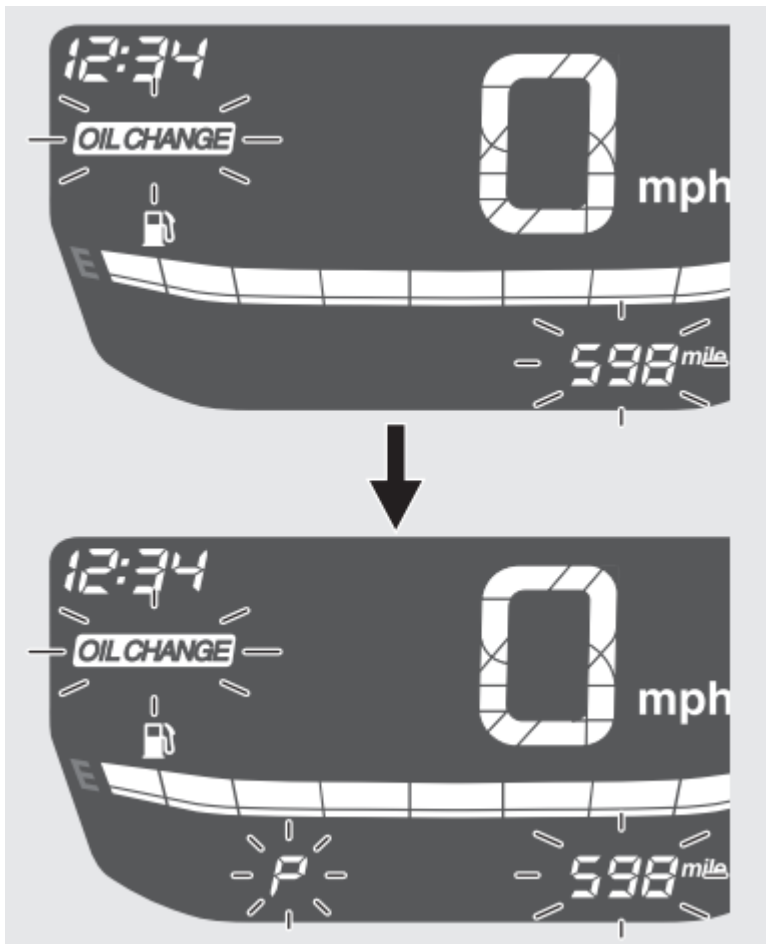

2. Press the SEL switch to select oil change interval.

- "P" turns off when the oil change interval is displayed.
- When the remaining distance until the OIL CHANGE indicator lights is displayed, the OIL CHANGE indicator

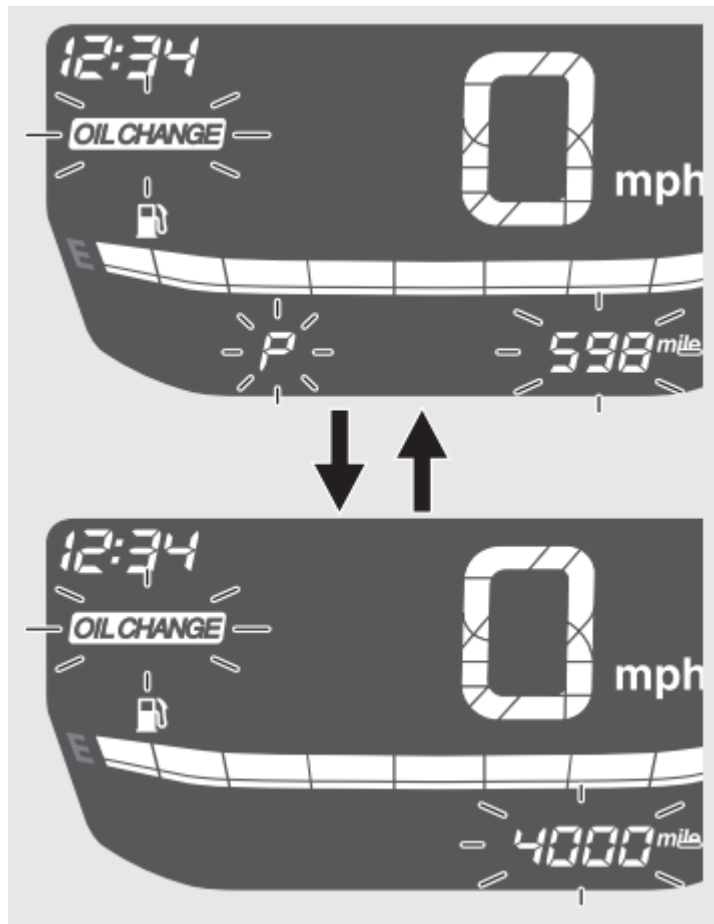

reset even if the SET switch is pressed

3. Press the SET switch and set the oil change interval. When this is set, the OIL CHANGE indicator is reset and the display moves to the remaining distance until V-BELT indicator lights. (V-BELT indicator starts flashing.)

**6. Remaining distance until V-BELT indicator lights display:**

**Confirming the remaining distance until V-BELT indicator lights**



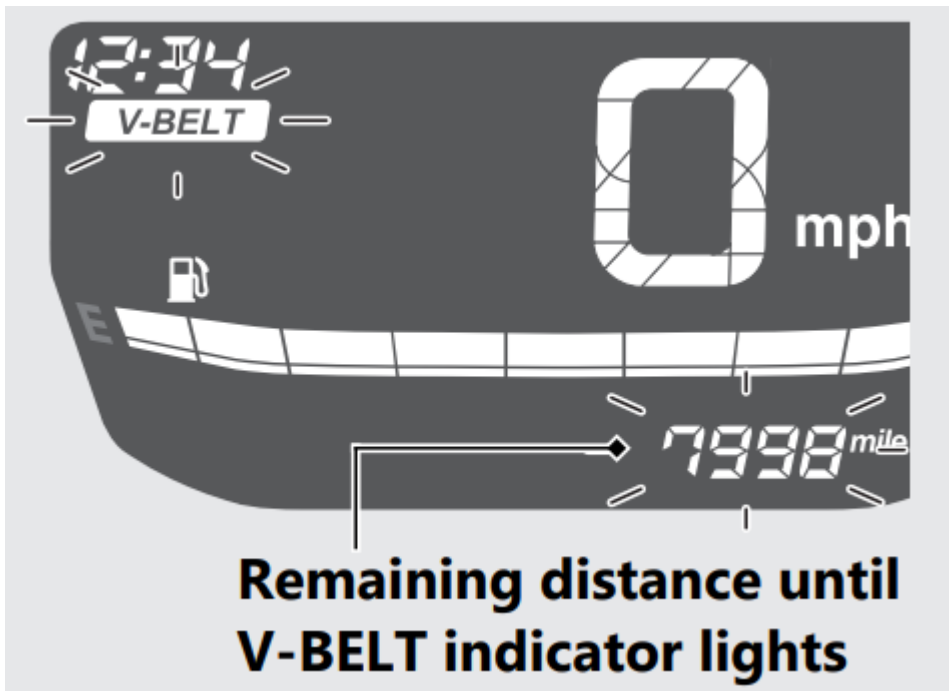

Display the remaining distance until the VBELT indicator lights.

#### **Resetting V-BELT indicator**

1. Press the SET switch. The V-BELT indicator and the remaining distance until the V-BELT indicator lights flash.
  - "P" flashes when the remaining distance until V-BELT indicator lights is displayed

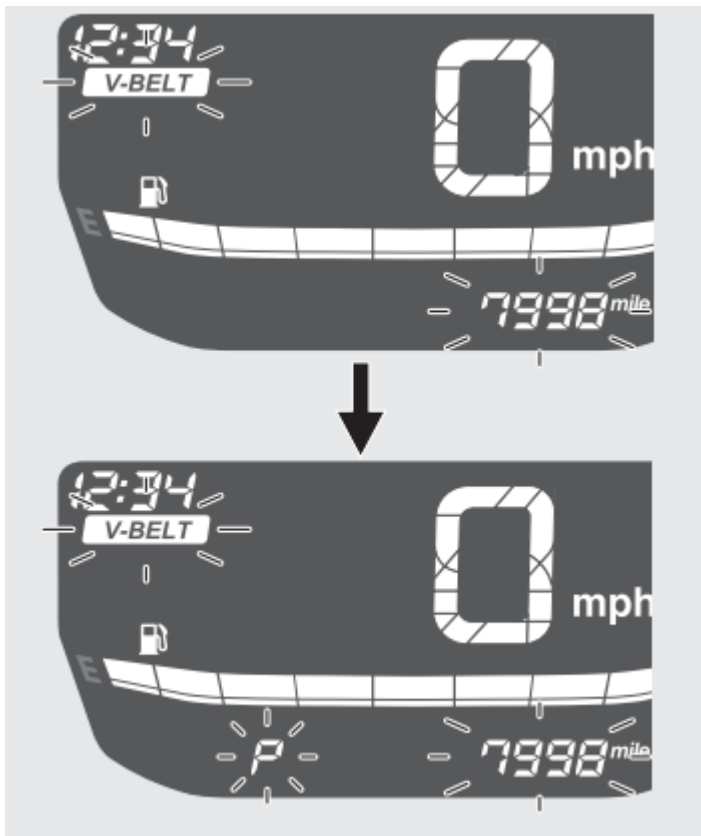

2. Press the SEL switch to select maintenance interval.

→ "P" turns off when the maintenance interval is displayed.

→ When the remaining distance until the V-BELT indicator lights is displayed, the V-BELT indicator does not reset even if the SET switch is pressed.

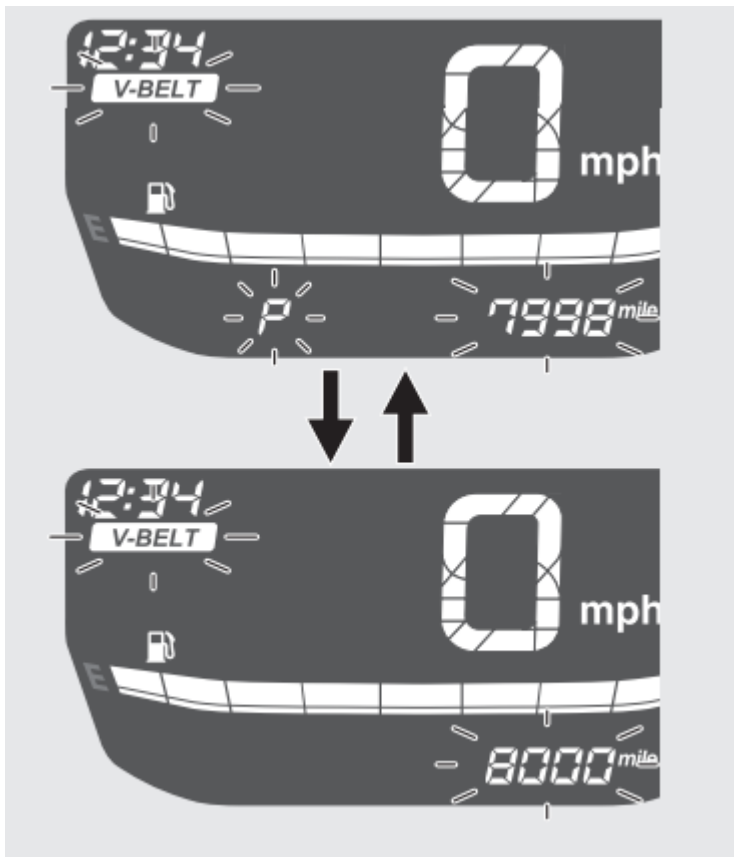

3. Press the SET switch and set the maintenance interval. When this is set, the V-BELT indicator is reset and the display moves to the normal display

## Indicators

If one of these indicators does not come on when it should, have your dealer check for problems.

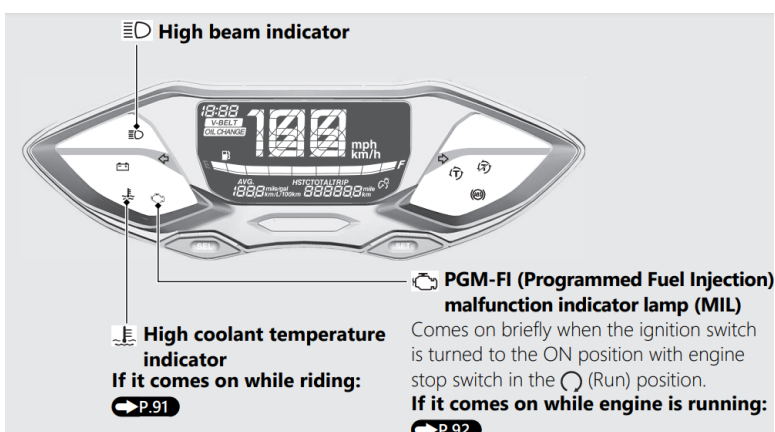

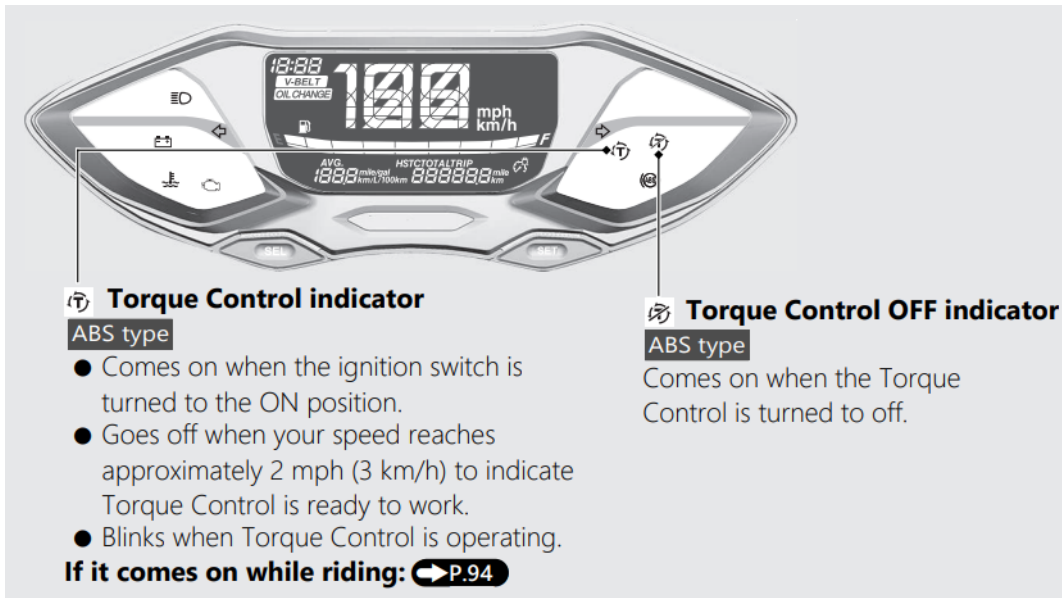
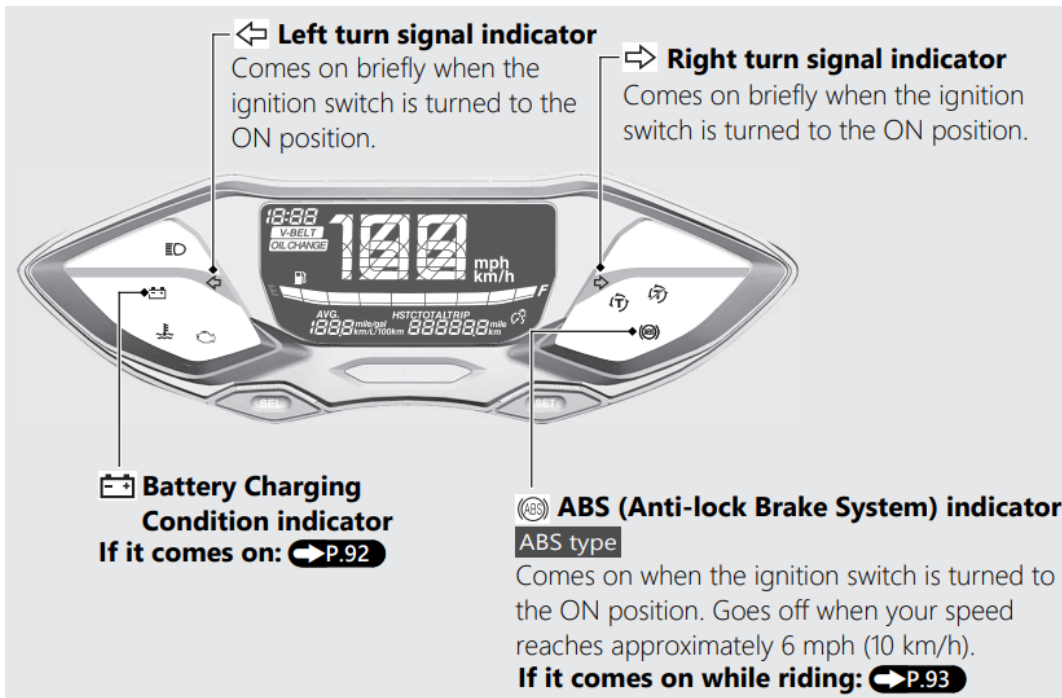

## Switches

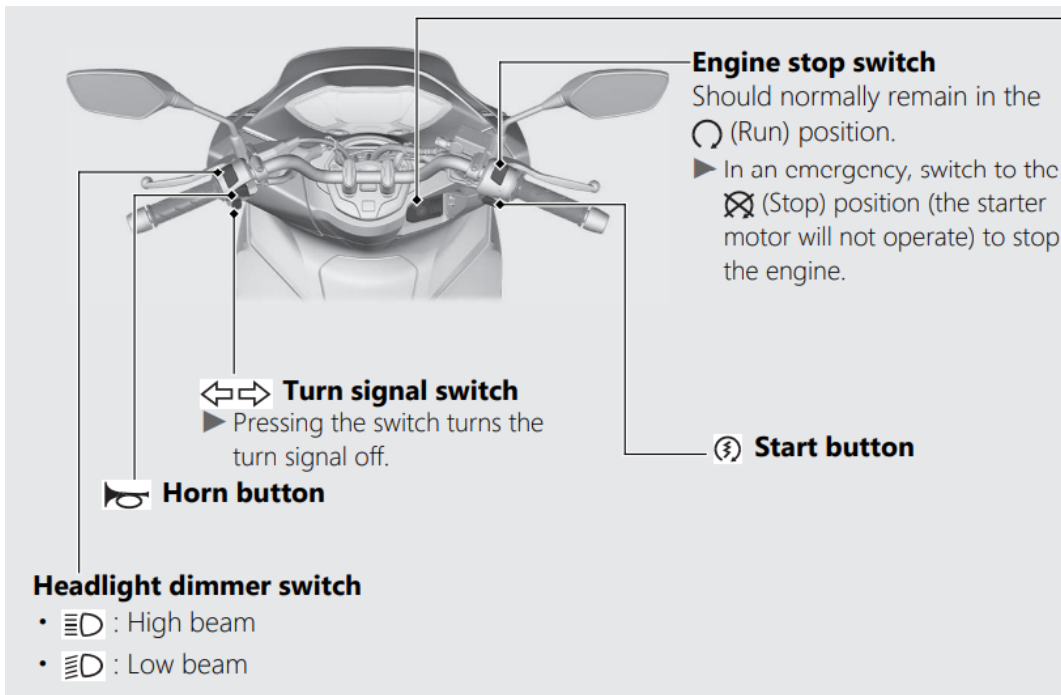

### Ignition switch

Switches the electrical system on/off, locks the steering, and operates the fuel lid and seat opener switch.

→ Key can be removed when in the OFF position or  (Lock) position.

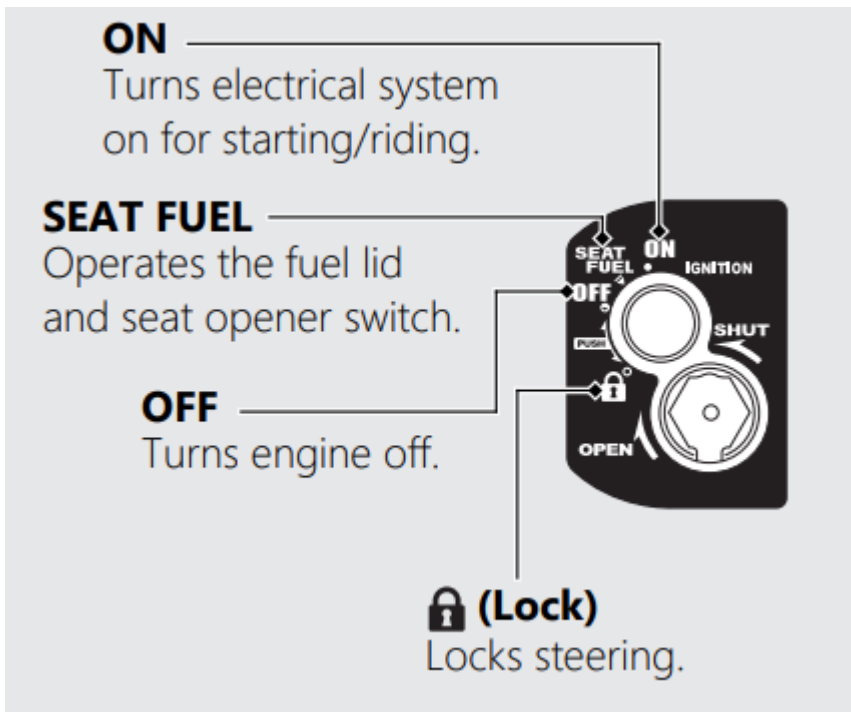

### Steering Lock

Lock the steering when parking to help prevent theft.

A U-shaped wheel lock or similar device is also recommended.

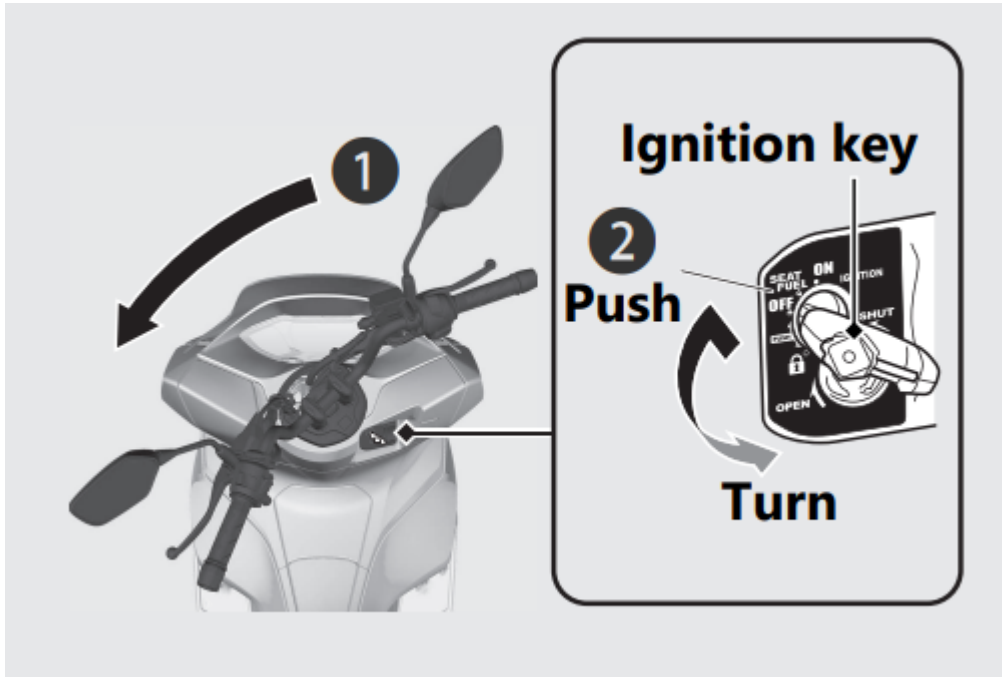

### Locking

1. Turn the handlebar all the way to the left or right.
2. Push the key down, and turn the ignition switch to the  (Lock) position.
  - Jiggle the handlebar if the lock is difficult to engage.
3. Remove the key

### Unlocking

Insert the key, push it in, and turn the ignition switch to the OFF position.

### Shutter

The ignition switch for this vehicle is equipped with an automatic shutter. After parking the vehicle, close the shutter for theft prevention.

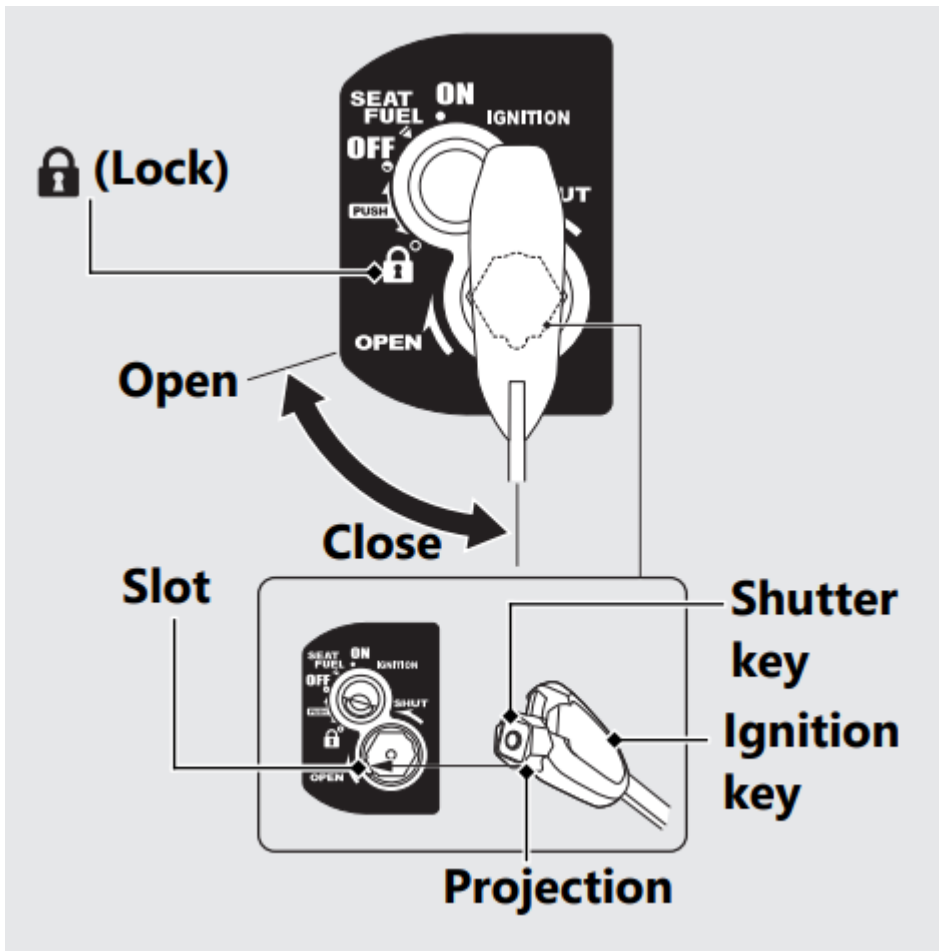

The shutter will automatically close when you remove the ignition key at the  (Lock) position.

Also you can close the shutter manually.

### Close

1. Remove the ignition key from the ignition switch.
2. Align the projection of the shutter key with the slot of the shutter, and turn the shutter key counterclockwise.
3. Remove the key

### Open

Align the projection of the shutter key with the slot of the shutter, and turn the shutter key clockwise.

## Rear Brake Lock

### Locking

Squeeze the rear brake lever and set the rear brake lock lever.

→ The rear brake lock will not function if the rear brake is not adjusted properly.

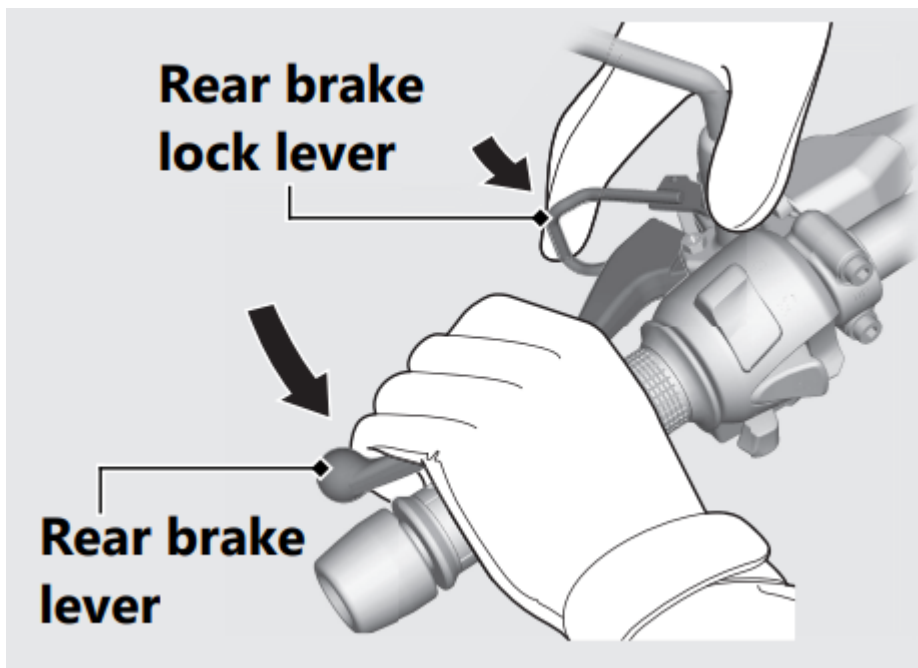

### Unlocking

Squeeze the rear brake lever

→ Before riding, make sure that the rear brake lock is fully released so there is no drag on the rear wheel.

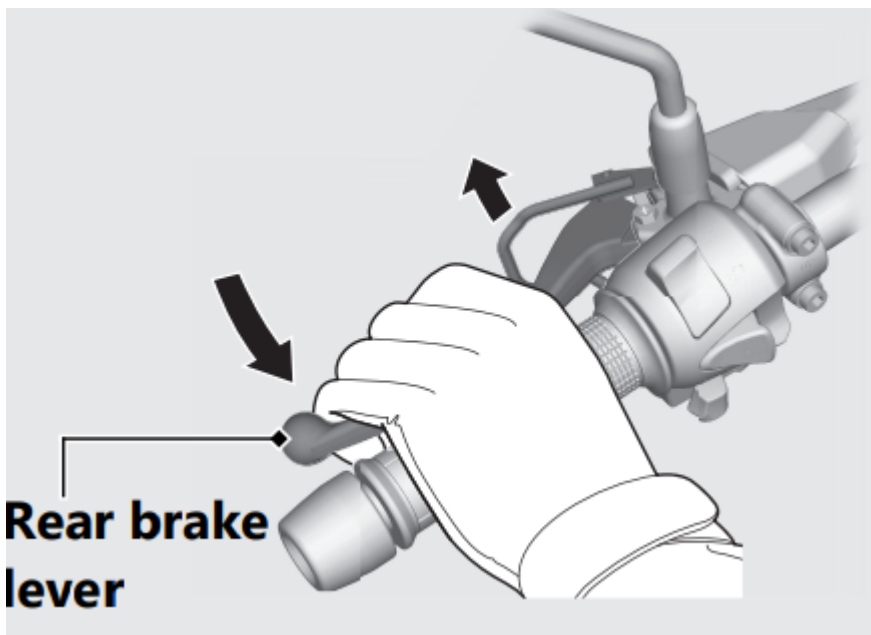

### Locking

Squeeze the rear brake lever and pull the brake lock knob.

→ The rear brake lock will not function if the rear brake is not adjusted properly

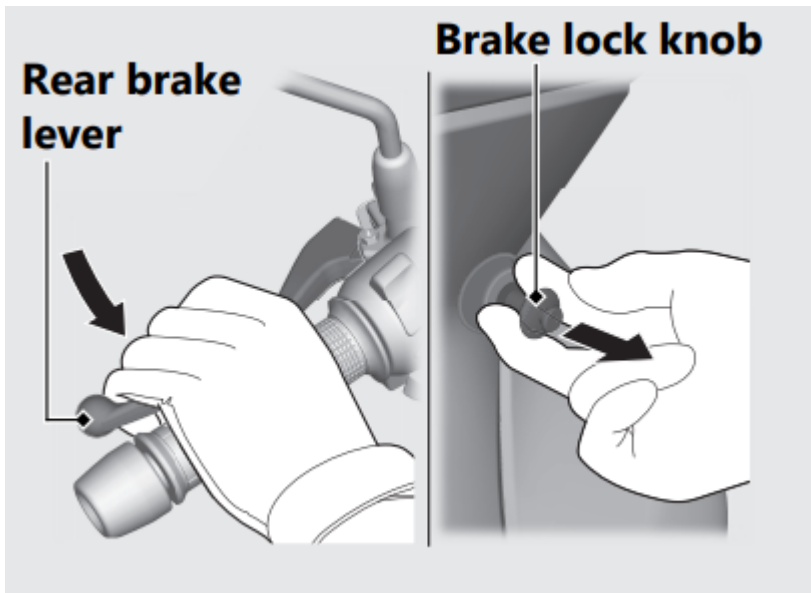

### Unlocking

Squeeze the rear brake lever and press the brake lock knob down while pushing in the center button.

→ Before riding, make sure that the rear brake lock is fully released so there is no drag on the rear wheel

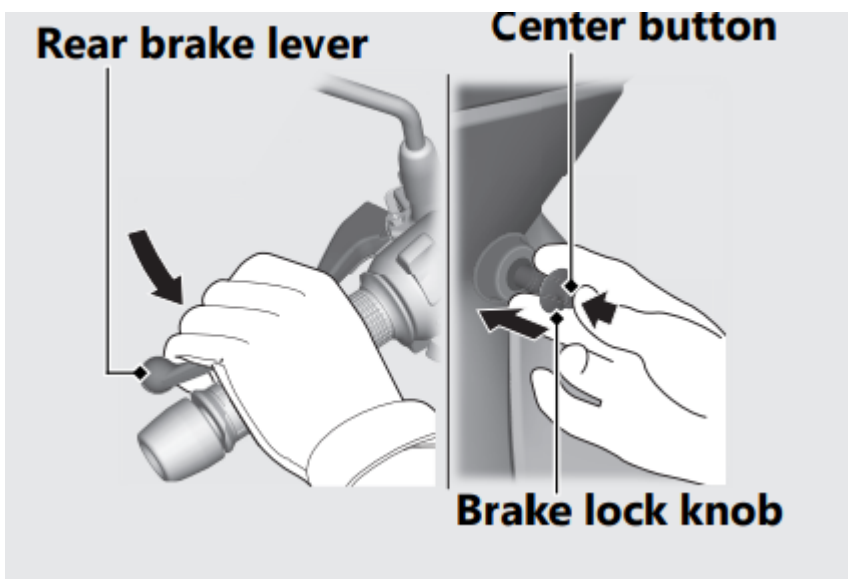

### Honda Selectable Torque Control

Torque Control (engine power control) can be turned on/off.

Stop the vehicle first, before turning the Torque Control off or on. u The Torque Control cannot be turned off when the system is activated (Torque Control indicator blinking). u Each time the ignition switch is turned to the ON position, the Torque Control will automatically be set to on.

### Torque Control on and off

Press SEL switch to display the Torque Control [HSTC]. Pressing and holding SET switch while Torque Control [HSTC] is displayed switches between on and off.

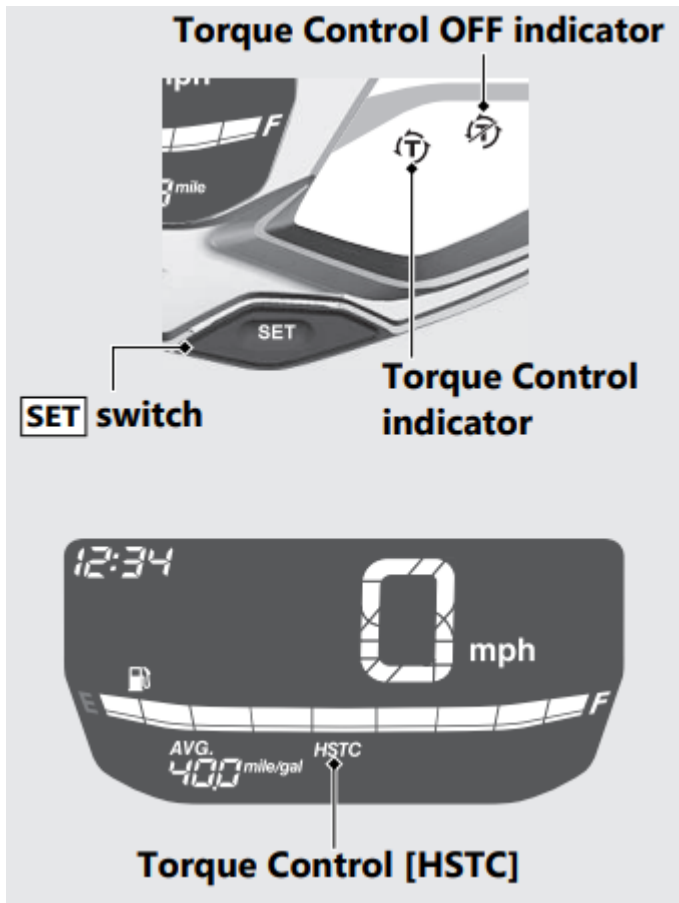

### Starting the Engine

Start your engine using the following procedure, regardless of whether the engine is cold or warm.

This vehicle is equipped with a side stand ignition cut-off system.

- If the side stand is down, the engine cannot be started.
- If you lower the side stand with the engine running, it will automatically shut off.

1. Place the vehicle on its center stand.

#### 2. ABS type

Lock the rear wheel by squeezing the rear brake lever and setting the rear brake lock lever.

#### Except ABS type

Lock the rear wheel by squeezing the rear brake lever and setting the brake lock knob.



→ The starter motor will only work when the rear brake lever is squeezed and the side stand is up

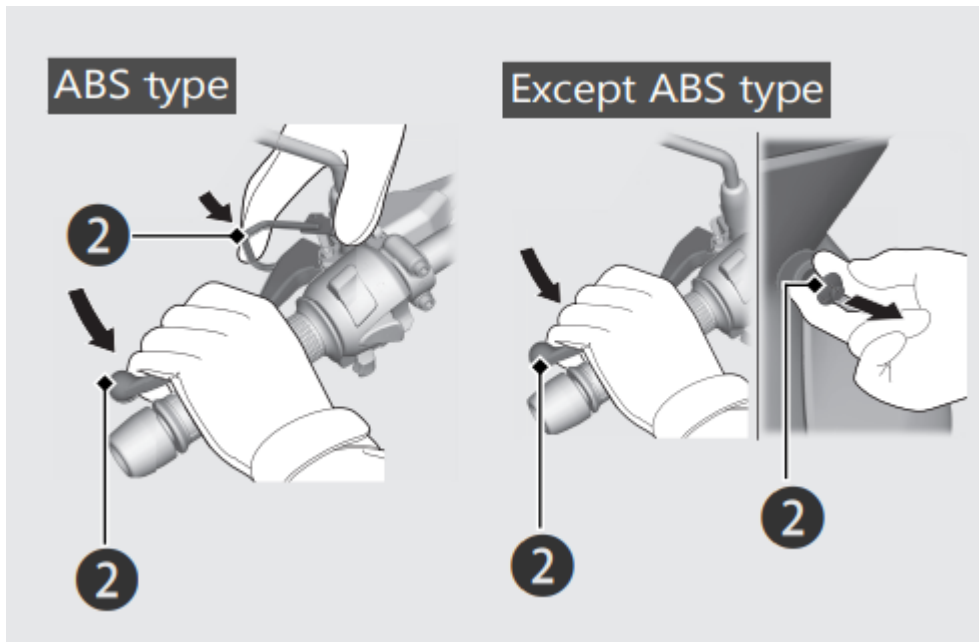

3. Make sure the engine stop switch is in the  (Run) position.
4. Turn the ignition switch to the ON position.

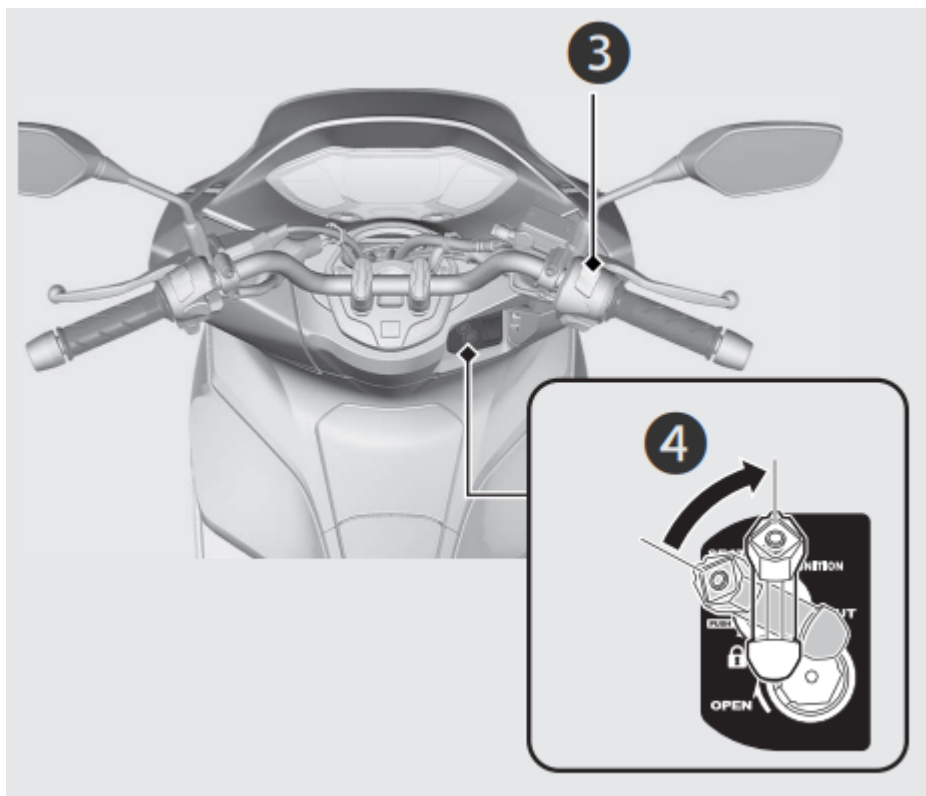

5. Press the start button with the throttle completely closed. Release the start button as soon as the engine starts.

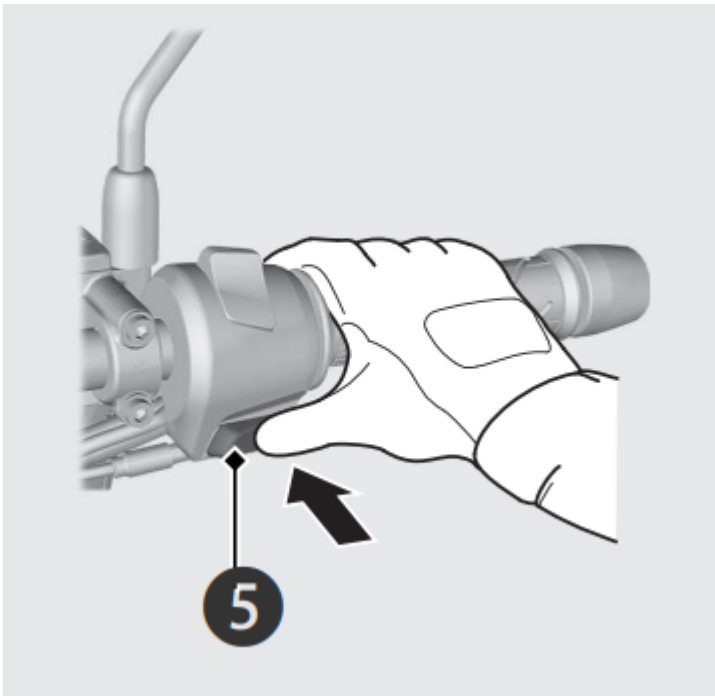

**If you cannot start the engine:**

1. Place the vehicle on its center stand and squeeze the rear brake lever.
2. With the throttle slightly open (about 1/8 in [3 mm], without freeplay), press the start button.

**About 1/8 in (3 mm), without freeplay**

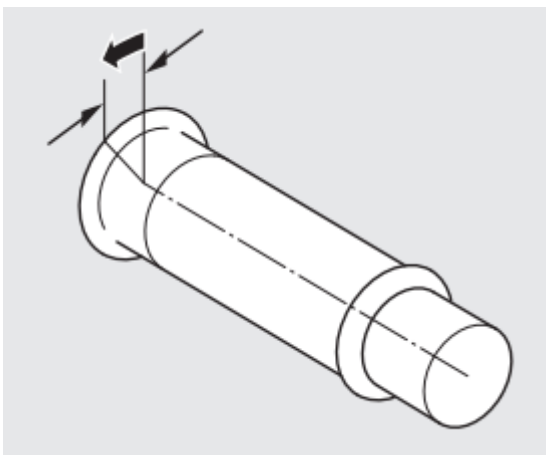

**If the engine does not start:**

1. Open the throttle fully and press the start button for 5 seconds.
2. Repeat the normal starting procedure.
3. If the engine starts, open the throttle slightly if idling is unstable.
4. If the engine does not start, wait 10 seconds before trying steps a & b again.

**Riding**

## Starting the Vehicle

1. Push the vehicle forward off the center stand.
  - Lock the rear brake lock.
  - Keep throttle closed. Make sure the side stand and center stand are up
2. Get on the vehicle.
  - Mount the vehicle from the left side, keeping at least one foot on the ground.
3. Release the rear brake lock.
4. Acceleration and deceleration To accelerate: Open the throttle slowly. Operation Guide To decelerate: Close the throttle.

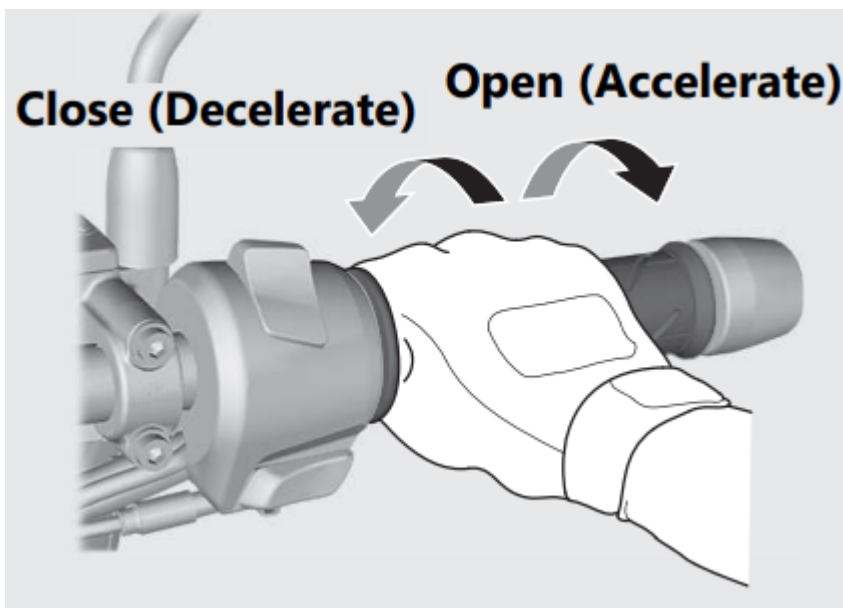

## Braking

Close the throttle and apply the front and rear brake levers together.

Do not apply the brake lock while riding. It may cause the wheel to lock, reducing control of the vehicle.

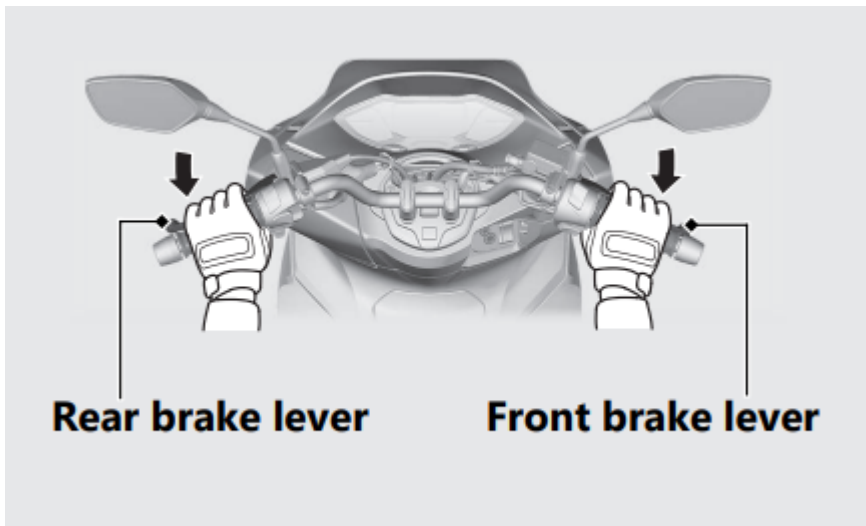

## Refueling

**Fuel type:** Unleaded gasoline only

**Recommended fuel octane number:** Pump Octane Number (PON) 86 or higher.

**Tank capacity:** 2.14 US gal (8.1 L)

### Opening the Fuel Fill Cap

1. Insert the ignition key and turn it to the position of SEAT FUEL.
2. Push the FUEL side of the fuel lid and seat opener switch.  
→ The fuel lid opens

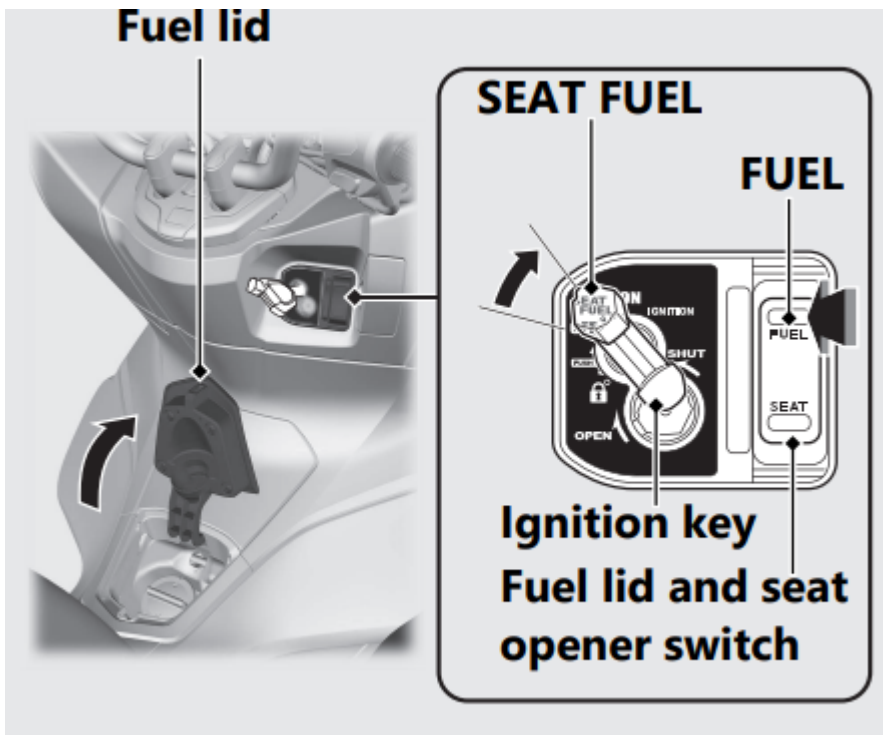

3. Turn the fuel fill cap counterclockwise and remove the fuel fill cap

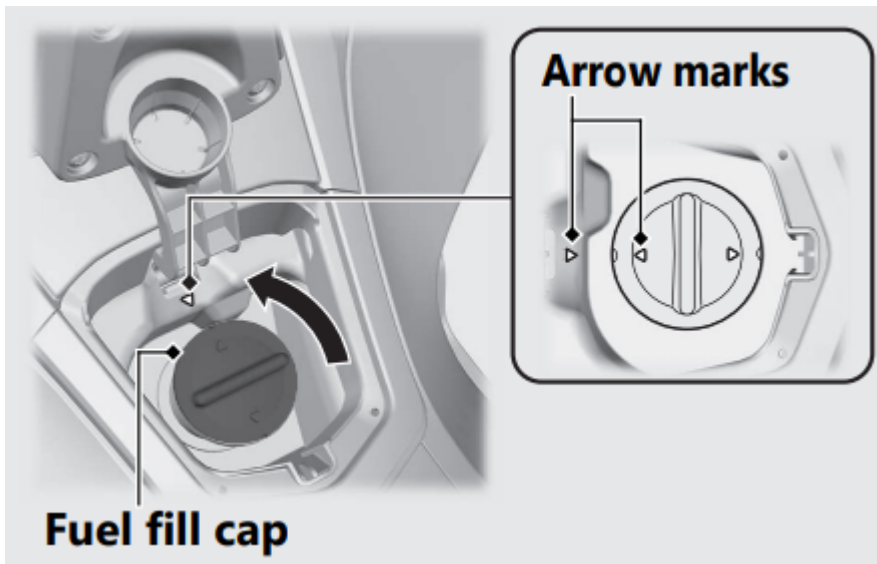

4. Put the removed fuel fill cap on the fuel fill cap resting place.

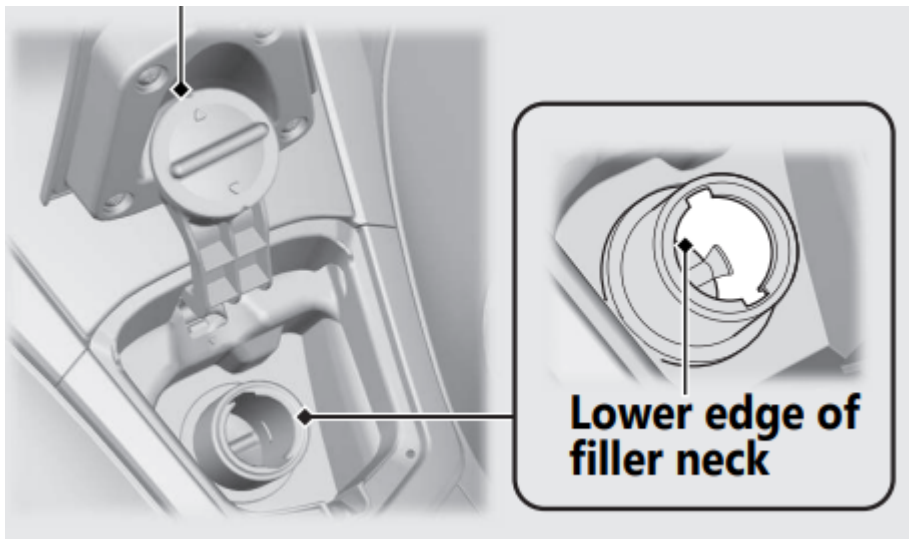

Do not fill with fuel above the lower edge of the filler neck.

### **Closing the Fuel Fill Cap**

1. Install and tighten the fuel fill cap firmly by turning it clockwise.
  - Make sure that the arrow marks on the fuel fill cap and fuel tank are aligned.
2. Close the fuel lid until it locks.
  - Make sure that the fuel lid is closed securely. 3WA

### **USB Socket**

The USB socket is located in the front box.

Use USB devices at your own risk. In no event shall Honda be liable for any damage to your USB device when in use.

Open the cover to access the USB socket. USB type-C connectors can be used.  
Rated capacity is 15 W (5 V, 3.0 A)

→ The USB socket is for charging only.

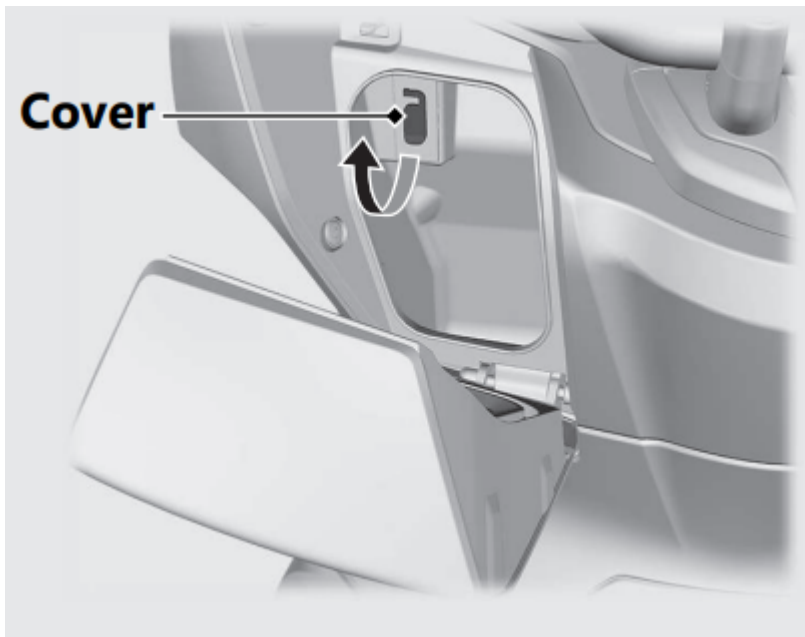

→ To prevent the battery from becoming weak (or dead), keep the engine running while drawing current from the USB socket.

→ To prevent entry of foreign matter into the USB socket, be sure to close the cover when the USB socket is not used.

### Storage Equipment

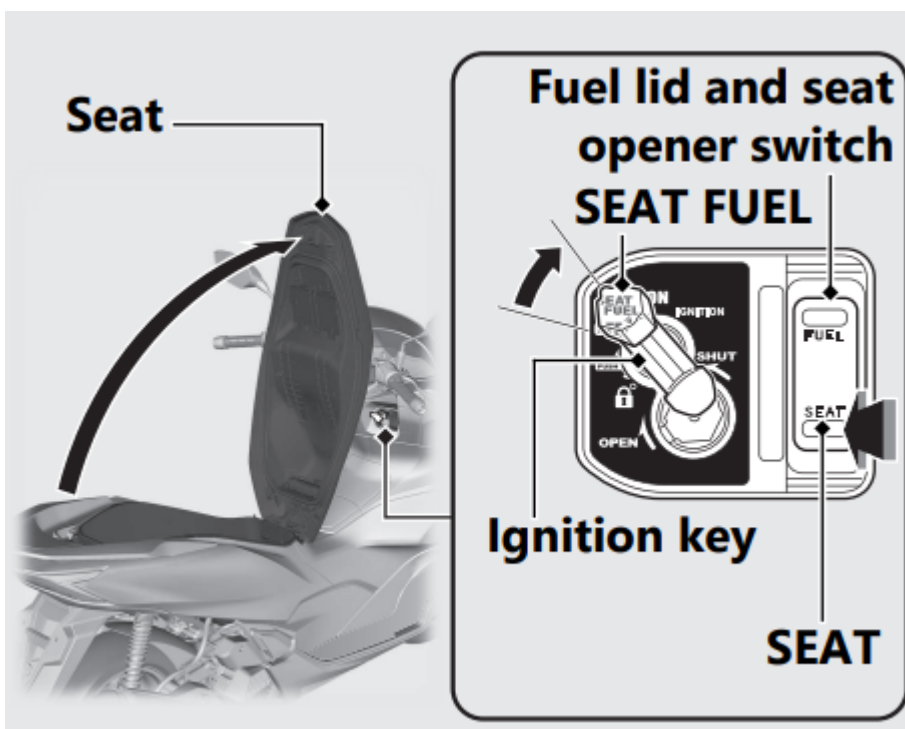

## Seat Open

1. Turn the handlebar pointed straight ahead.
2. Insert the ignition key and turn it to the position of SEAT FUEL. 3. Push the SEAT side of the fuel lid and seat opener switch.
4. Open the seat.

## Seat Close

Close and push down on the rear of the seat until it locks. Make sure that the seat is locked securely by pulling it up lightly. Take care not to lock your key in the compartment under the seat

## Helmet Holder

The helmet holder is located under the seat.

→ Use the helmet holder only when parked.

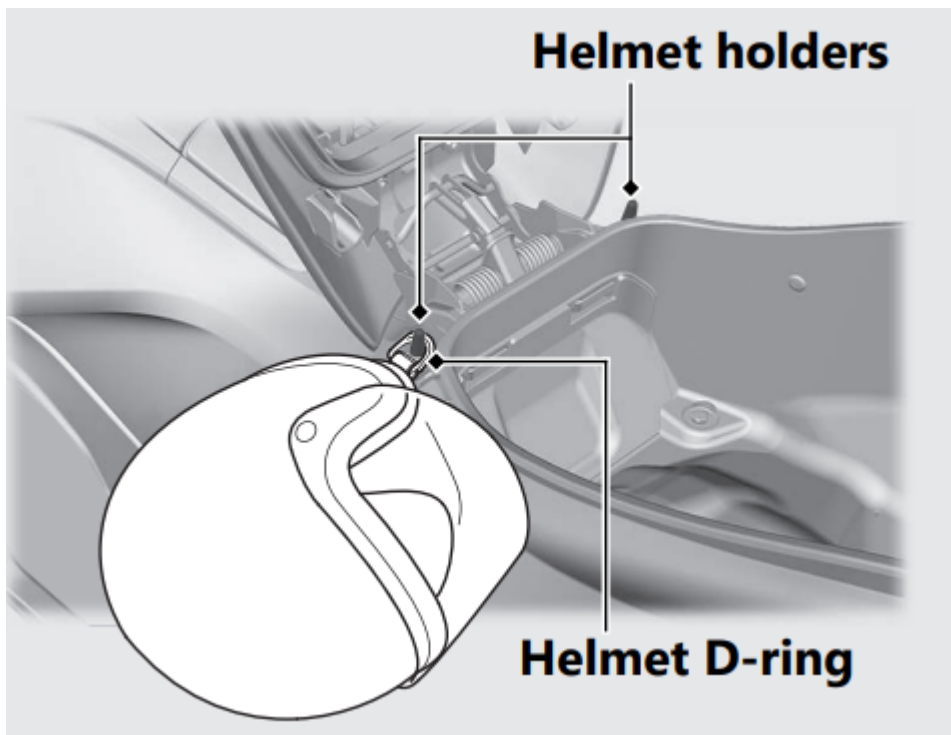

A helmet can be stored in the center compartment.

Set in the front of the helmet forward.

→ Some helmets may not fit in the compartment due to their size or design.

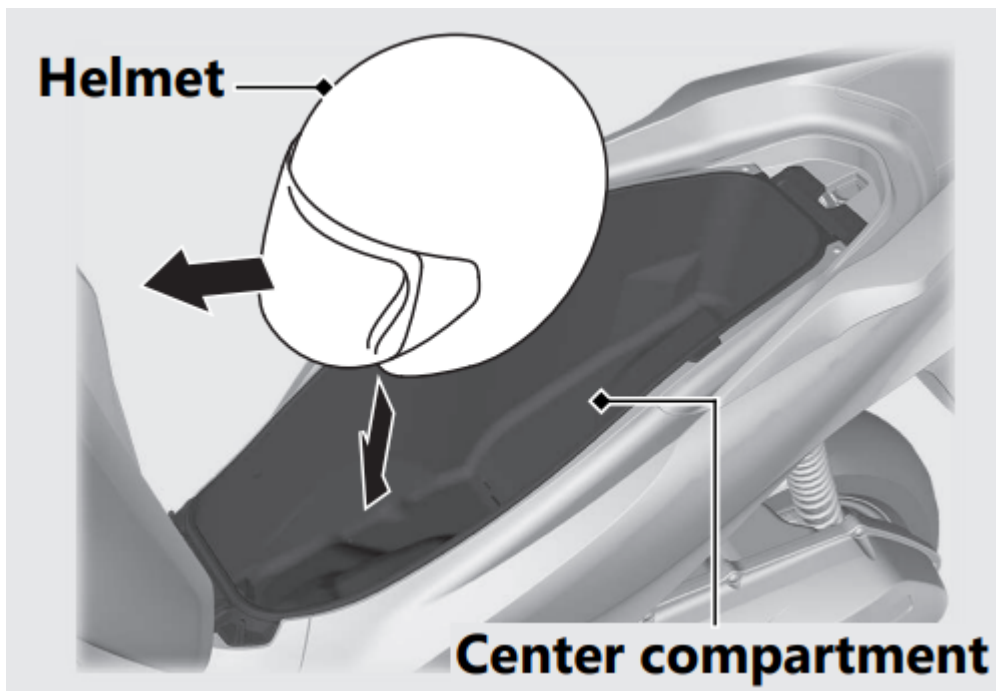

### **Center compartment**

Never exceed the maximum weight limit.

### **Maximum Weight: 22 lb (10 kg)**

- Do not store any items that are flammable or susceptible to heat damage.
- Do not store valuables or fragile articles.

### **Document Bag**

The document bag is located underside of Operation Guide the seat by the rubber straps.

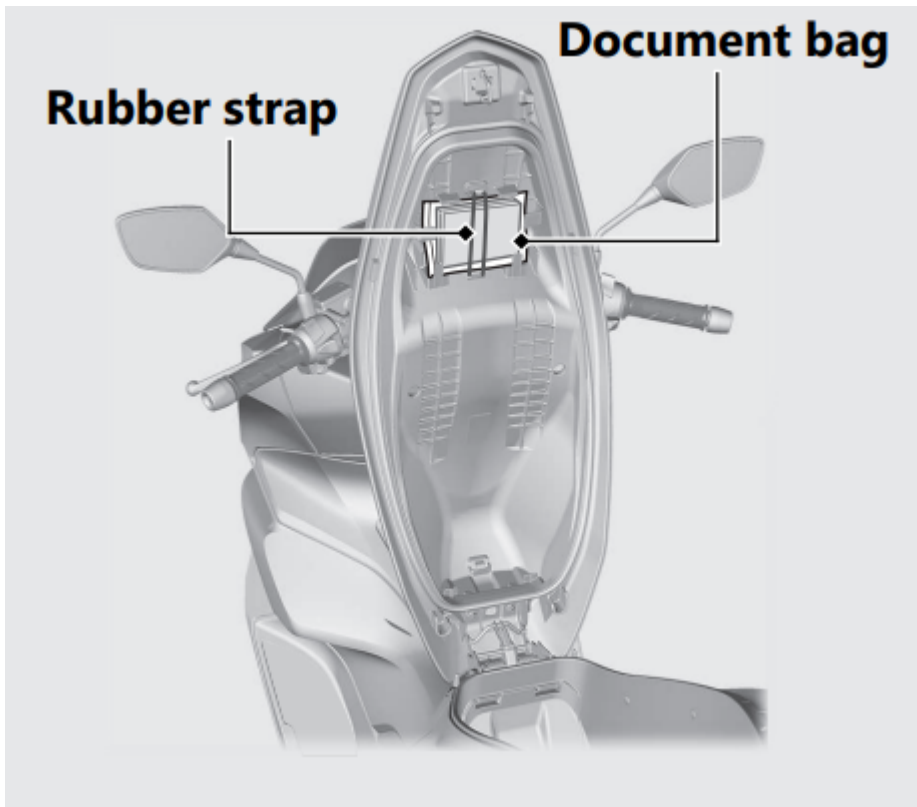

## Front Box

### Open

Push the front box lid, then open the front box lid.

### Close

Close the front box lid by pressing the front box lid.

The maximum allowable load in the front box shall be no more than

**2.0 lb (1.0 kg)**

Make sure that the front box lid is closed securely.

→ Do not store valuables or fragile articles.

## Maintenance

### Maintenance Schedule

The maintenance schedule specifies the maintenance requirements necessary to ensure safe, dependable performance, and proper emission control.

Maintenance work should be performed in accordance with Honda's standards and specifications by properly trained and equipped technicians. Your dealer meets all of these requirements. All scheduled maintenance is considered a normal owner-

operating cost and will be charged to you by your dealer. Keeping an accurate maintenance record will help ensure your vehicle is properly maintained.

Make sure whoever performs the scheduled maintenance completes the maintenance record. Retain all service documents. If you sell your vehicle, these service documents should be transferred with the vehicle to the new owner.

Items	Frequency <sup>*1</sup>									
	× 1,000 mi	0.6	4	8	12	16	20	24	Regular Replace	Refer to page
	× 1,000 km	1.0	6.4	12.8	19.2	25.6	32.0	38.4		
Fuel Line			I	I	I	I	I	I		-
Throttle Operation			I	I	I	I	I	I		88
Air Cleaner <sup>*2</sup>					R			R		-
Crankcase Breather <sup>*3</sup>			C	C	C	C	C	C		-
Spark Plug			I	R	I	R	I	R		-
Valve Clearance			I	I	I	I	I	I		-
Engine Oil		R	R	R	R	R	R	R	1 Year	77
Engine Oil Strainer Screen				C		C		C		-
Engine Idle Speed			I	I	I	I	I	I		-
Radiator Coolant <sup>*5</sup>				I		I		I	3 Years	79
Cooling System				I		I		I		-
Evaporative Emission Control System <sup>*4</sup>					I			I		-

### Maintenance Level



Intermediate. We recommend service by your dealer, unless you have the necessary tools and are mechanically skilled. Procedures are provided in an official Honda Service Manual (→ P. 118).



Technical. In the interest of safety, have your vehicle serviced by your dealer.

### Maintenance Legend



Inspect (clean, adjust, lubricate, or replace, if necessary)



Replace



Clean

Items	Frequency*1									Regular Replace	Refer to page
	× 1,000 mi	0.6	4	8	12	16	20	24			
	× 1,000 km	1.0	6.4	12.8	19.2	25.6	32.0	38.4			
Drive Belt				I		R					-
Final Drive Oil *5										2 Years	-
Brake Fluid*5			I	I	I	I	I	I		2 Years	81
Brake Shoes/Pads Wear			I	I	I	I	I	I			82, 86
Brake System			I	I	I	I	I	I			63
Brake Lock Operation			I	I	I	I	I	I			40
Headlight Aim			I	I	I	I	I	I			-
Clutch Shoes Wear						I					-
Side Stand			I	I	I	I	I	I			87
Suspension			I	I	I	I	I	I			-
Nuts, Bolts, Fasteners				I		I		I			-
Wheels/Tires			I	I	I	I	I	I			71
Steering Head Bearings				I		I		I			-

**Notes:**

- \*1 : At higher odometer reading, repeat at the frequency interval established here.
- \*2 : Service more frequently when riding in unusually wet or dusty areas.
- \*3 : Service more frequently when riding in rain or at full throttle.
- \*4 : 50 STATE (meets California).
- \*5 : Replacement requires mechanical skill.

**Maintenance Record**

Distance	Odometer	Date	Performed By:	Notes
600 miles (1,000 km)				
4,000 miles (6,400 km)				
8,000 miles (12,800 km)				
12,000 miles (19,200 km)				
16,000 miles (25,600 km)				
20,000 miles (32,000 km)				
24,000 miles (38,400 km)				
28,000 miles (44,800 km)				
32,000 miles (51,200 km)				
36,000 miles (57,600 km)				
40,000 miles (64,000 km)				
44,000 miles (70,400 km)				
48,000 miles (76,800 km)				
52,000 miles (83,200 km)				
56,000 miles (89,600 km)				
60,000 miles (96,000 km)				
64,000 miles (102,400 km)				
68,000 miles (108,800 km)				

**Maintenance Fundamentals**

**Pre-ride Inspection**

To ensure safety, it is your responsibility to perform a pre-ride inspection and make sure that any problem you find is corrected. A preride inspection is a must, not only for



safety, but because having a breakdown, or even a flat tire, can be a major inconvenience.

Check the following items before you get on your vehicle:

- Tire tread wear and air pressures are within limits → P. 71
- Lights, horn, and turn signals operate normally

Check the following items if you are carrying a passenger or cargo:

- Combined weight is within load limits → P. 125
- Cargo is secured properly

Check the following items after you get on your vehicle:

- Throttle action moves smoothly without binding → P. 88
- Brake levers operate normally
- Check the fuel level and refuel when needed → P. 13, → P. 48
- Engine stop switch functions properly → P. 36

Check the following items at regular intervals:

- Oil level is between the upper and lower level marks → P. 77

- **ABS type**

Brake fluid level is above the LWR level mark → P. 81

- **Except ABS type**

Brake fluid level is Front: above the LWR level mark → P. 81 Combi Brake:  
between the UPPER and LOWER level marks → P. 81

- Engine coolant level is between the UPPER and LOWER level marks → P. 79
- Side stand functions properly → P. 87
- Rear brake lock works properly → P. 40

### **Periodic Checks**

You should also perform other periodic maintenance checks at least once a month regardless of how often you ride, or more often if you ride frequently.

Also, check the odometer reading against the Maintenance Schedule and perform all maintenance that is due. → P. 59

Tires and wheels	Check the air pressure (→ P. 71), examine tread for wear and damage (→ P. 71), and check the wheels for damage.
Fluid levels	Check the engine oil level (→ P. 77), engine coolant level (→ P. 79), and brake fluid level (→ P. 81).
Lights	Check that the headlight, position lights, brake light, taillight, turn signals, and license plate light are working properly
Controls	Check the freeplay of the rear brake lever (→ P. 83), throttle grip (→ P. 88) and rear brake lock (→ P. 40) operate properly.
Fuses	Check that you have a full supply of spare fuses.
Nuts & bolts	Check the major nuts and bolts, and tighten as needed

### Replacing Parts

Always use Honda Genuine Parts or their equivalents to ensure reliability and safety. When ordering colored components, specify the model name, color, and code mentioned on the color label.

The color label is attached to the center compartment. → P. 54

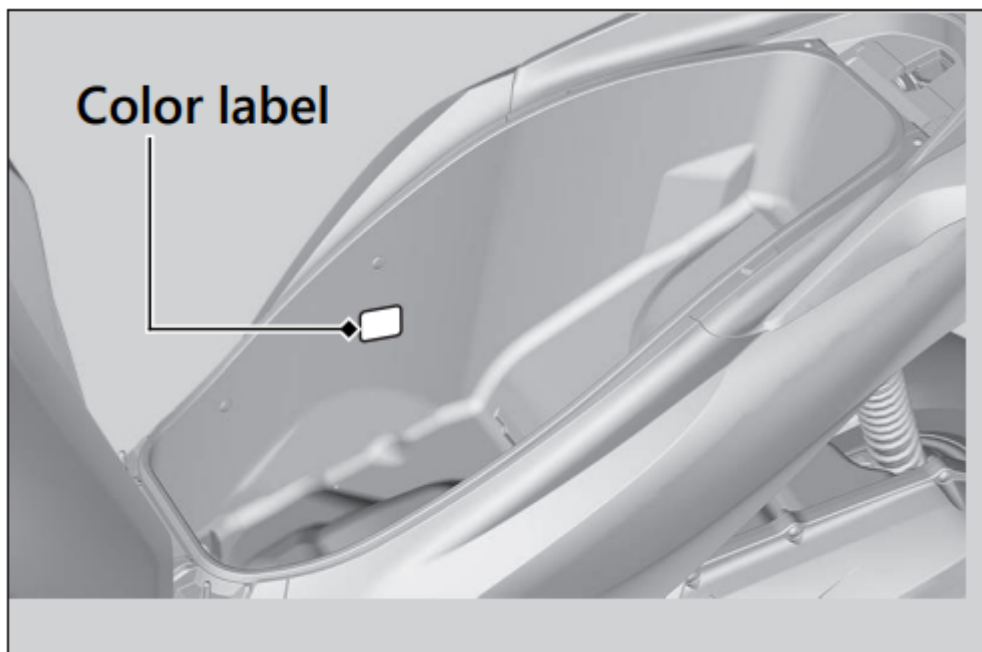

### Battery

Your vehicle has a maintenance-free type battery. You do not have to check the battery electrolyte level or add distilled water. Clean the battery terminals if they become dirty or corroded.

Do not remove the battery cap seals. There is no need to remove the cap when charging.

### **What to do in an emergency**

If any of the following occur, immediately see your doctor.

- Electrolyte splashes into your eyes:
  - Wash your eyes repeatedly with cool water for at least 15 minutes. Using water under pressure can damage your eyes.
- Electrolyte splashes onto your skin:
  - Remove affected clothing and wash your skin thoroughly using water.
- Electrolyte splashes into your mouth:
  - Rinse mouth thoroughly with water, and do not swallow.

### **Cleaning the Battery Terminals**

1. Remove the battery. → P. 75
2. If the terminals are starting to corrode and are coated with a white substance, wash with warm water and wipe clean.
3. If the terminals are heavily corroded, clean and polish the terminals with a wire brush or sandpaper. Wear safety glasses.

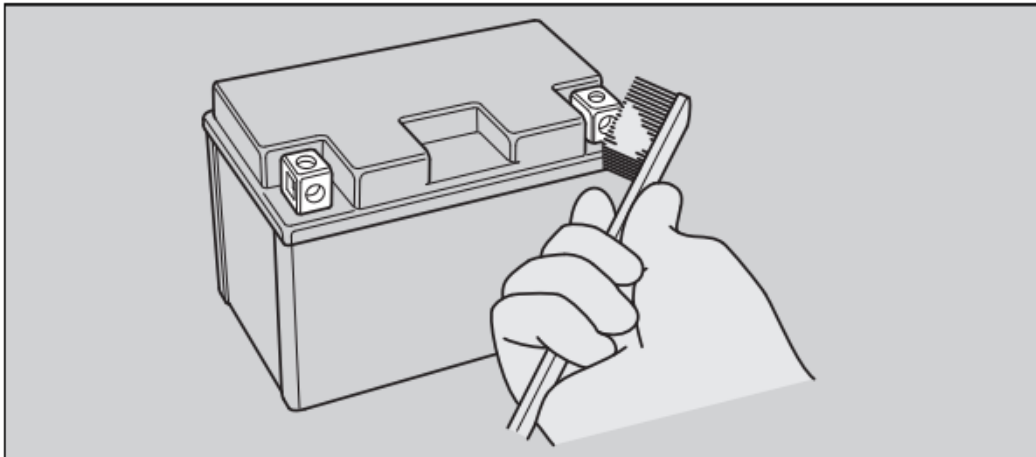

4. After cleaning, reinstall the battery

The battery has a limited life span. Consult your dealer about when you should replace the battery. Always replace the battery with another maintenance-free battery of the same type.

### **Charging**

If you use electrical accessories that drain the battery or you do not ride frequently, we recommend that you charge the battery every 30 days using a charger designed specifically for your Honda, which can be purchased from your dealer. Read the information that came with your battery charger and follow the instructions on the battery. Avoid using an automobile-type battery charger, as these can overheat a motorcycle battery and cause permanent damage.

Make sure the ignition switch is in the OFF position before charging the battery.

## Fuses

### Inspecting and Replacing Fuses

Turn the ignition switch to the OFF position to remove and inspect fuses. If a fuse is blown, replace with a fuse of the same rating. For fuse ratings, see “Specifications.” → P. 127

If a fuse fails repeatedly, you likely have an electrical fault. Have your vehicle inspected by your dealer.

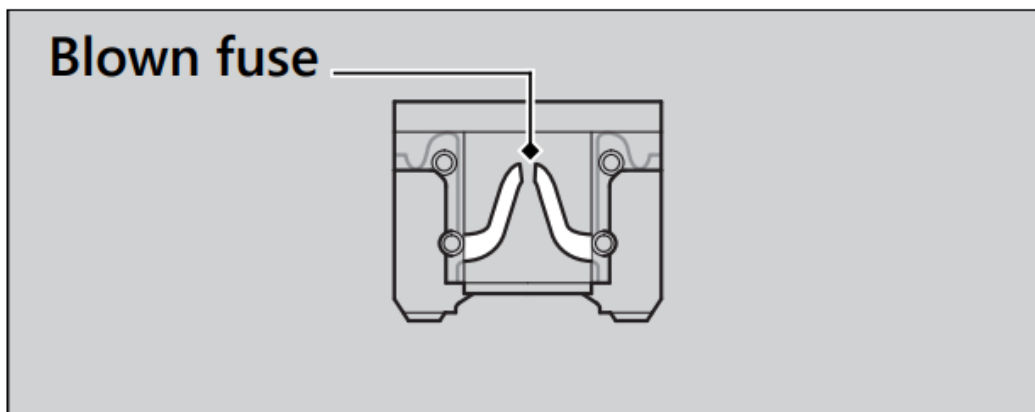

## Engine Oil

### Selecting the Engine Oil

For recommended engine oil, see “Specifications.” → P. 126 If you use non-Honda engine oil, check the label to make sure that the oil satisfies all of the following standards:

- JASO T 903 standard\*1: MB
- SAE standard\*2: 10W-30
- API classification\*3: SJ or higher

\*1. The JASO T 903 standard is an index for engine oils for 4-stroke motorcycle engines. There are two classes: MA and MB. For example, the following label shows the MB classification.

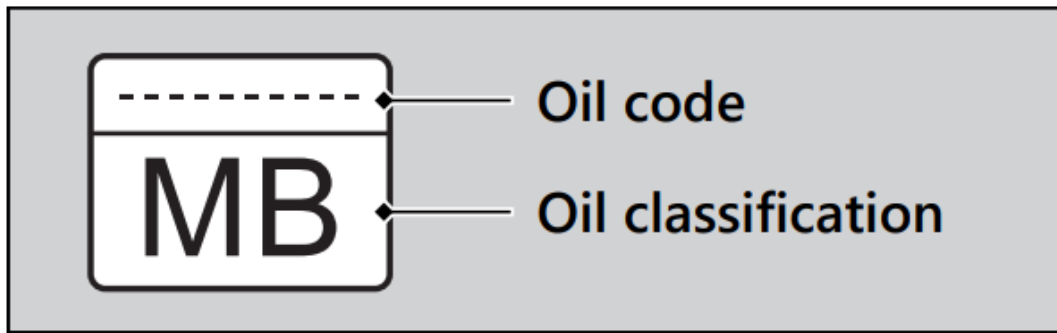

\*2. The SAE standard grades oils by their viscosity.

\*3. The API classification specifies the quality and performance rating of engine oils. Use SJ or higher oils, excluding oils marked as “Energy Conserving” or “Resource Conserving” on the circular API service symbol.

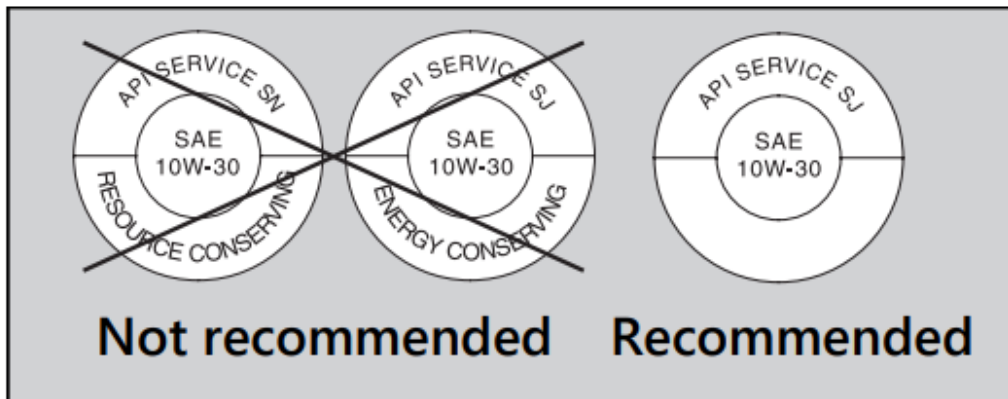

### Brake Fluid

Do not add or replace brake fluid, except in an emergency. Use only fresh brake fluid from a sealed container. If you do add fluid, have the brake system serviced by your dealer as soon as possible.

### Recommended Coolant

Pro Honda HP Coolant is a pre-mixed solution of antifreeze and distilled water

## Concentration:

50% antifreeze and 50% distilled water

A concentration of antifreeze below 40% will not provide proper corrosion and cold temperature protection.

A concentration of up to 60% will provide better protection in colder climates.

### Crankcase Breather

Service more frequently when riding in rain, at full throttle, or after the vehicle is washed or overturned. Service if the deposit level can be seen in the transparent section of the drain tube.

If the drain tube overflows, the air filter may become contaminated with engine oil, causing poor engine performance.

## **Tires (Inspecting/Replacing)**

### **Checking the Air Pressure**

Visually inspect your tires and use an air pressure gauge to measure the air pressure at least once a month or any time you think the tires look low. Always check air pressure when your tires are cold.

### **Inspecting for Damage**

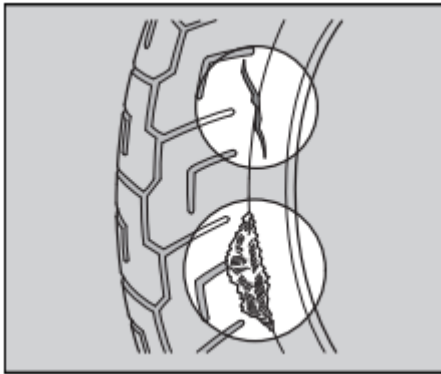

Inspect the tires for cuts, slits, or cracks that expose fabric or cords, or nails or other foreign objects embedded in the side of the tire or the tread. Also inspect for any unusual bumps or bulges in the side walls of the tires.

### **Inspecting for Abnormal Wear**

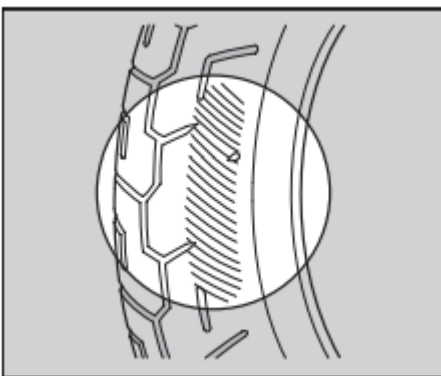

Inspect the tires for signs of abnormal wear on the contact surface.

### **Inspecting Tread Depth**

Inspect the tread wear indicators. If they become visible, replace the tires immediately. For safe riding, you should replace the tires when the minimum tread depth is reached.

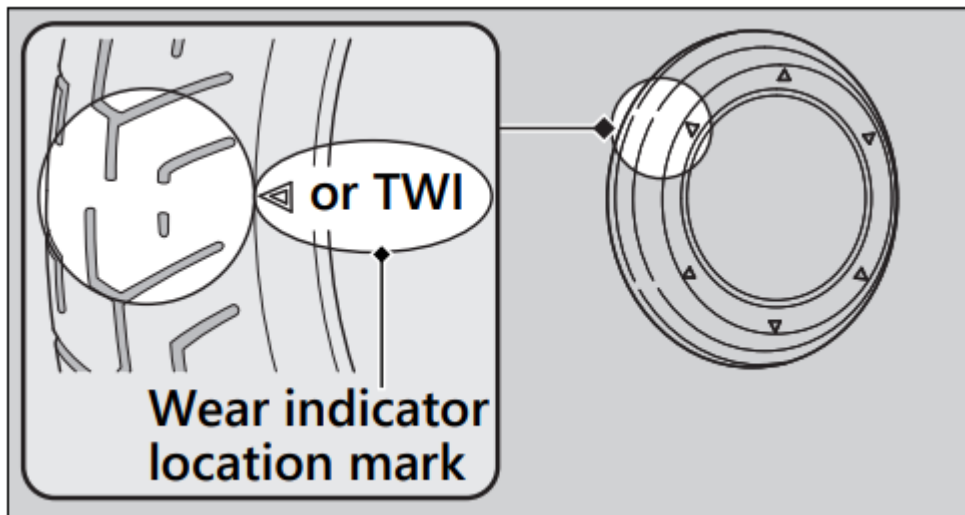

Have your tires replaced by your dealer. For recommended tires, air pressure, and minimum tread depth, see “Specifications.” → P. 126 Follow these guidelines whenever you replace tires:

- Use the recommended tires or their equivalents of the same size, construction, speed rating, and load range.
- Do not install a tube inside a tubeless tire on this vehicle. Excessive heat build-up can cause the tube to burst.
- Use only tubeless tires on this vehicle. The rims are designed for tubeless tires, and during hard acceleration or braking, a tubetype tire could slip on the rim and cause the tire to rapidly deflate.

### **Tire Service Life**

The service life of your tires is dependent on many factors, including, but not limited to, riding habits, road conditions, vehicle loading, tire air pressure, maintenance history, speed, and environmental conditions (even when the tires are not in use).

In addition to your regular inspections and maintenance, it is recommended that you have annual inspections performed once the tires reach 5 years old. It is also recommended that all tires be removed from service after 10 years from the date of manufacture, regardless of their condition or state of wear.

The last four digits of the TIN (tire identification number) indicate the date of manufacture.

### **Tire Identification Number (TIN)**

The tire identification number (TIN) is a group of numbers and letters located on the sidewall of the tire

①      ②      ③

**DOT XXXX XXXX 22 09**

DOT: This indicates that the tire meets all requirements of the U.S. Department of Transportation.

a XXXX: Factory code

b XXXX: Tire type code

c 22 09: Date of manufacture (week & year). Example: week 22 in year 09.

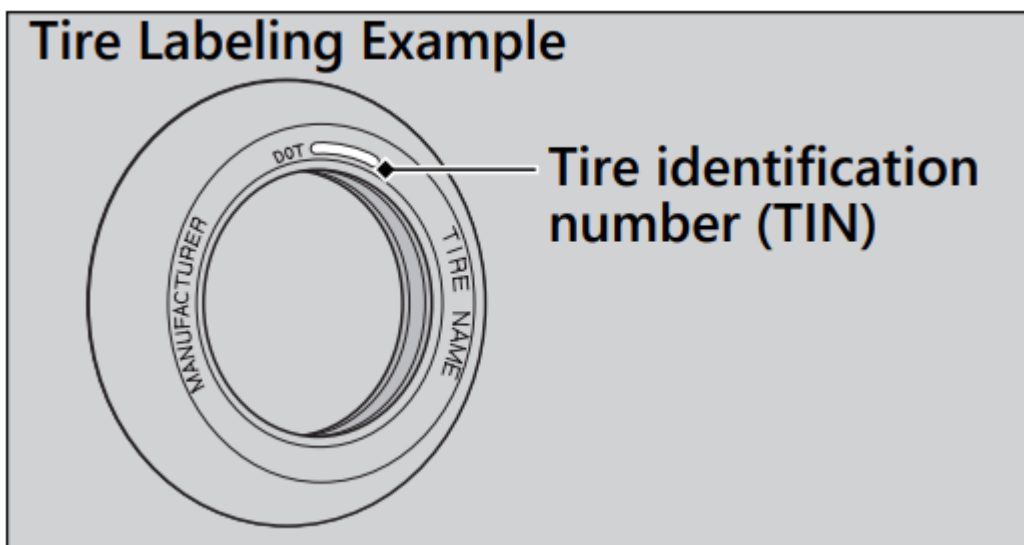

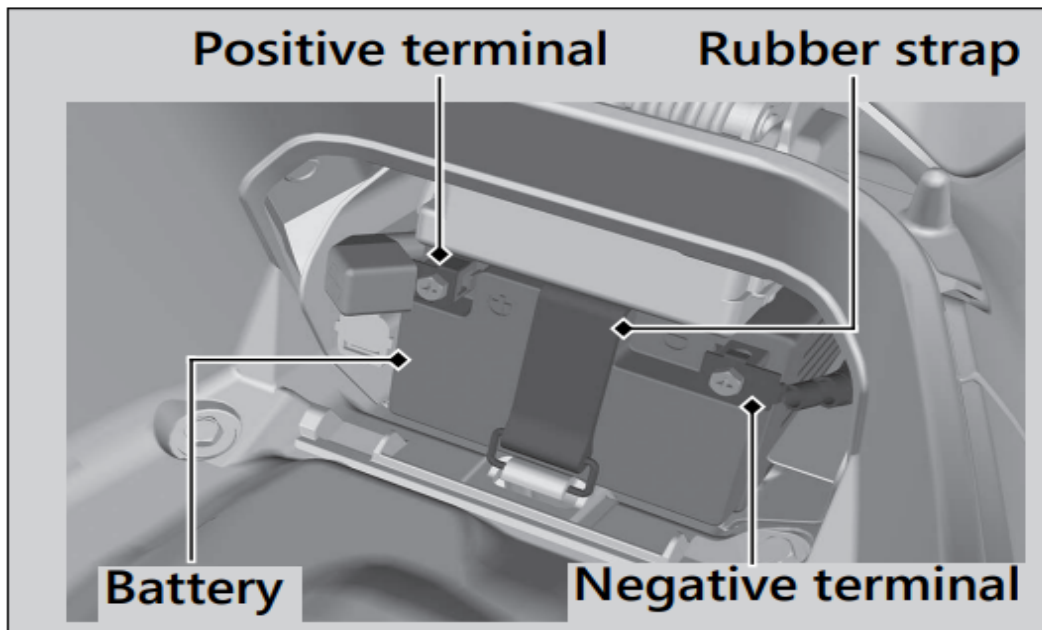

## Removing & Installing Body Components

### Battery



### Removal

Make sure the ignition switch is in the OFF position.

1. Remove the battery cover. → P. 76
2. Unhook the rubber strap.
3. Disconnect the negative  terminal from the battery.
4. Disconnect the positive  terminal from the battery.
5. Remove the battery, taking care not to drop the terminal nuts.

### Installation

Install the parts in the reverse order of removal. Always connect the positive

 terminal first. Make sure bolts and nuts are tight.

Make sure the clock information is correct after the battery is reconnected. → P.

26 For proper handling of the battery, see “Maintenance Fundamentals.” → P.

66 “Battery Goes Dead.” → P. 97

### Battery Cover

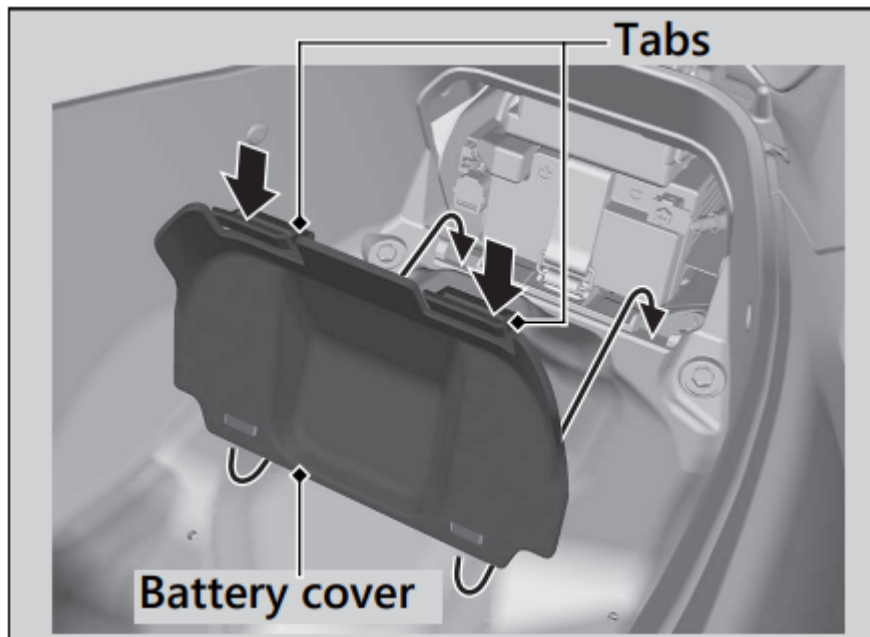

### Removal

1. Open the seat. → P. 52
2. Press the tabs and remove the battery cover.

### Installation

Install the parts in the reverse order of removal.

## Engine Oil

### Checking the Engine Oil

1. If the engine is cold, idle the engine for 3 to 5 minutes.
2. Turn the ignition switch to the OFF position and wait for 2 to 3 minutes.
3. Place your vehicle on its center stand on a firm, level surface.
4. Remove the oil fill cap/dipstick and wipe it clean.
5. Insert the oil fill cap/dipstick until it seats, but don't screw it in.
6. Check that the oil level is between the upper level and lower level marks on the oil fill cap/dipstick.
7. Securely install the oil fill cap/dipstick.

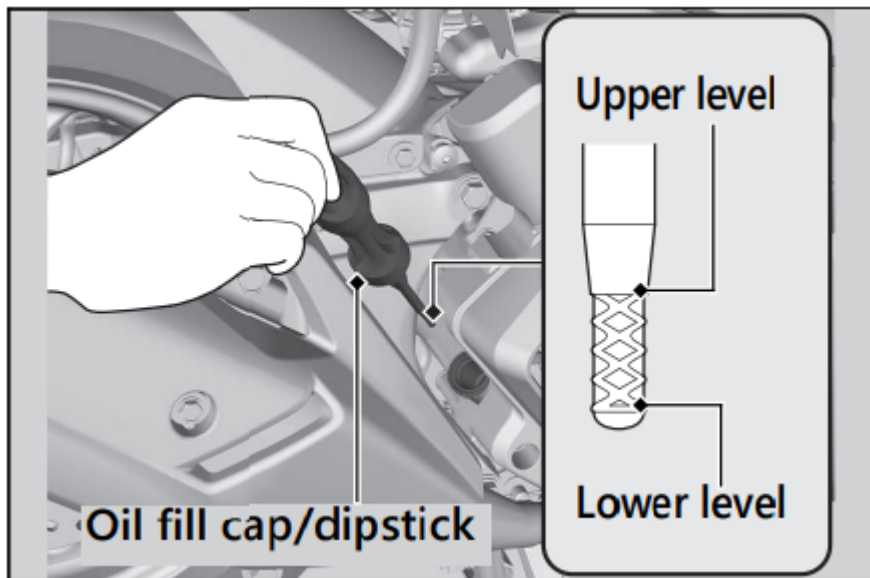

### **Adding Engine Oil**

If the engine oil is below or near the lower level mark, add the recommended engine oil. → P. 69, → P. 126

1. Remove the oil fill cap/dipstick. Add the recommended oil until it reaches the upper level mark.
  - Place your vehicle on its center stand on a firm, level surface when checking the oil level.
  - Do not overfill above the upper level mark.
  - Make sure no foreign objects enter the oil filler opening.
  - Wipe up any spills immediately.
2. Securely reinstall the oil fill cap/dipstick.

For the recommended oil and oil selection guidelines, see “Maintenance Fundamentals.” → P. 69

### **Coolant**

#### **Checking the Coolant**

Check the coolant level in the reserve tank while the engine is cold.

1. Place your vehicle on its center stand on a firm, level surface.
2. Check that the coolant level is between the UPPER level and LOWER level marks on the reserve tank.

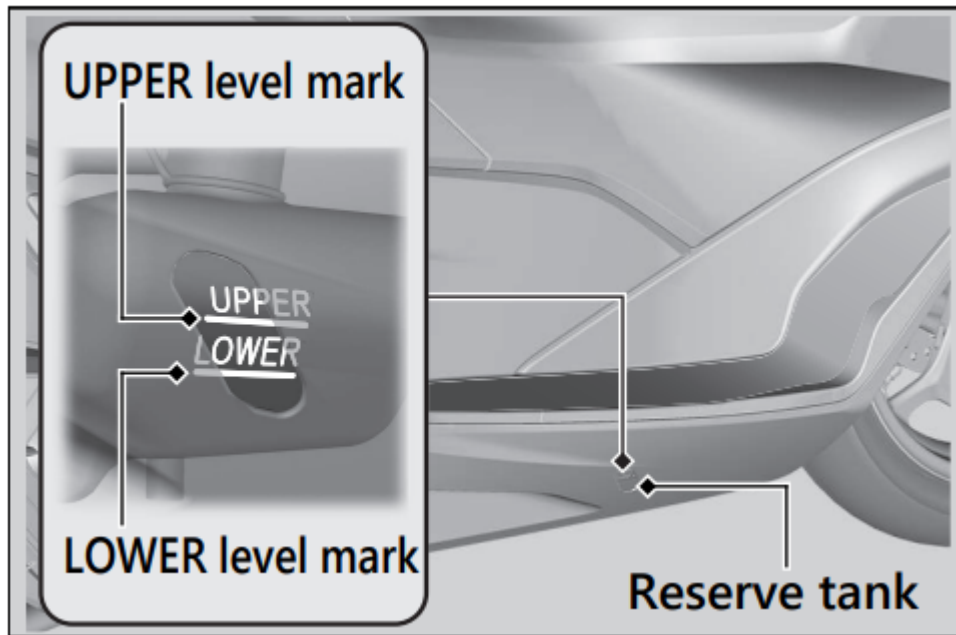

If the coolant level is dropping noticeably or the reserve tank is empty, you likely have a serious leak. Have your vehicle inspected by your dealer

### **Adding Coolant**

If the coolant level is below the LOWER level mark, add the recommended coolant (→ P. 70) until the level reaches the UPPER-level mark.

Add fluid only from the reserve tank cap and do not remove the radiator cap.

1. Pull the floor mat off.
2. Remove the reserve tank lid by inserting a flathead screwdriver covered with a protective cloth into the slit on the right side floor.
3. Remove the reserve tank cap and add fluid while monitoring the coolant level.
  - Do not overfill above the UPPER-level mark.
  - Make sure no foreign objects enter the reserve tank opening.
4. Securely reinstall the reserve tank cap.
5. Install the reserve tank lid and floor mat.

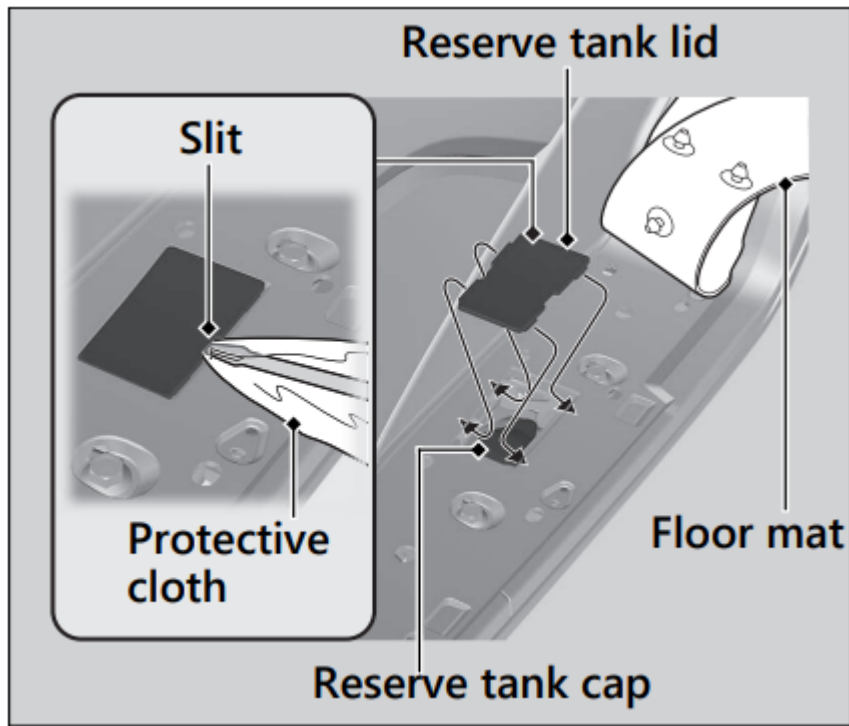

## Brakes

### Checking Brake Fluid

1. Place your vehicle in an upright position on a firm, level surface.
2. Check that the brake fluid reservoir cap is horizontal and that the fluid level is: Front brake above the LWR mark. Combi brake (Except ABS type) between the LOWER level and UPPER-level marks.

If the brake fluid level in either reservoir is below the LWR mark or LOWER level mark or the brake lever free play becomes excessive, inspect the brake pads for wear. If the brake pads are not worn, you most likely have a leak. Have your vehicle inspected by your dealer.

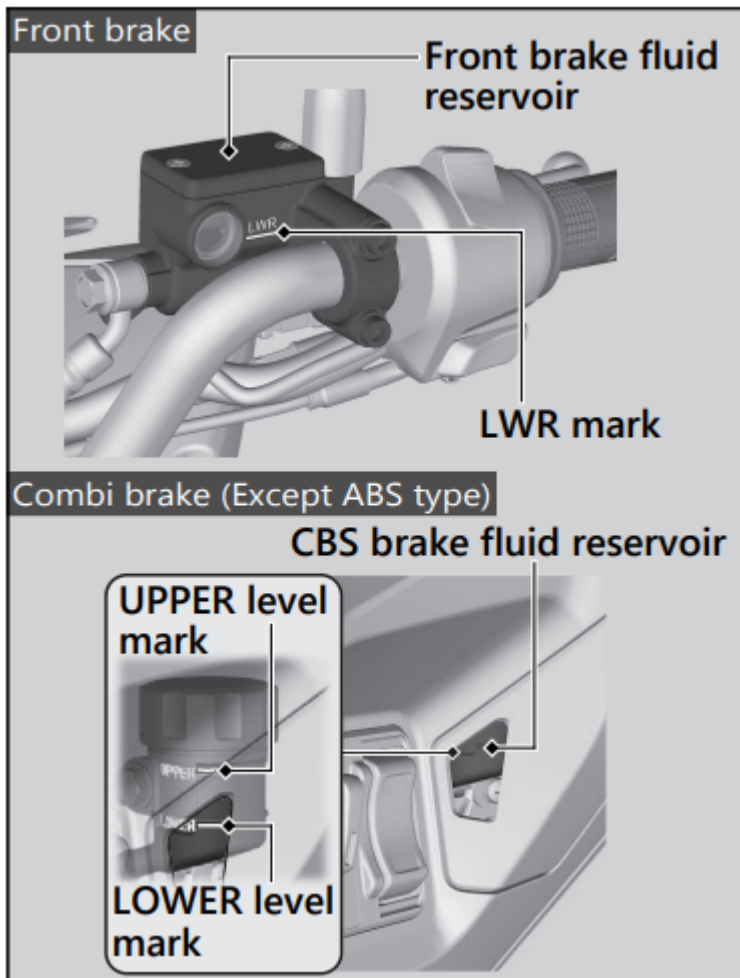

### Inspecting the Front Brake Pads

Check the condition of the brake pad wear indicators. The pads need to be replaced if a brake pad is worn to the bottom of the indicator.

1. Inspect the brake pads from in front of the brake caliper. If necessary, have the pads replaced by your dealer. Always replace both left and right brake pads at the same time.

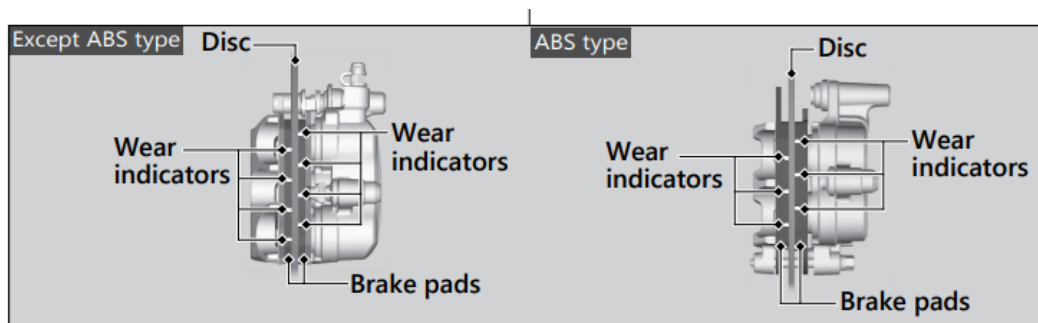

### Inspecting the Rear Brake Lever Freeplay

1. Place the vehicle on its center stand.

2. Measure the distance the rear brake lever moves before the brake takes hold

### **Freeplay at the tip of the brake lever:**

3/8 - 13/16 in (10 - 20 mm)

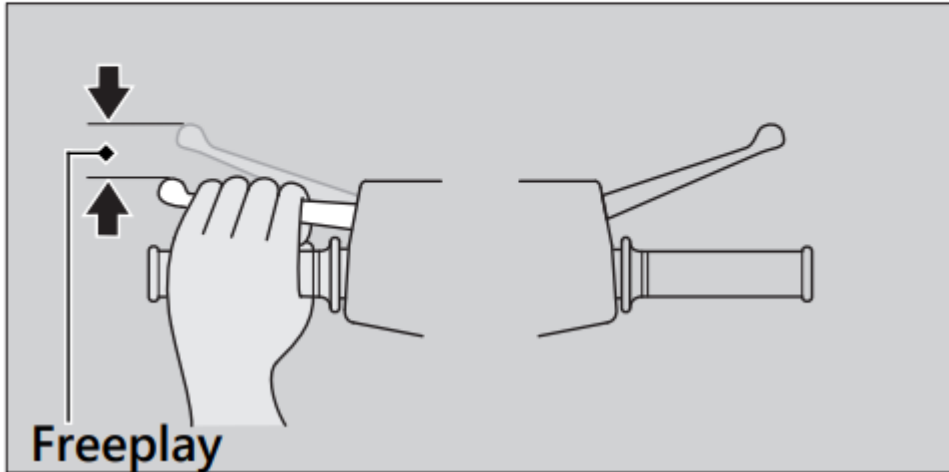

Check the brake cable for kinks or signs of wear. If necessary, have it replaced by your dealer.

Lubricate the brake cable with a commercially available cable lubricant to prevent premature wear and corrosion. Make sure the brake arm, spring and fastener are in good condition.

#### **Adjusting the Rear Brake Lever Freeplay**

Adjust the freeplay of the brake lever with the front wheel pointed straight ahead. Make sure the cut-out on the adjusting nut is seated on the brake arm pin when adjusting the freeplay.

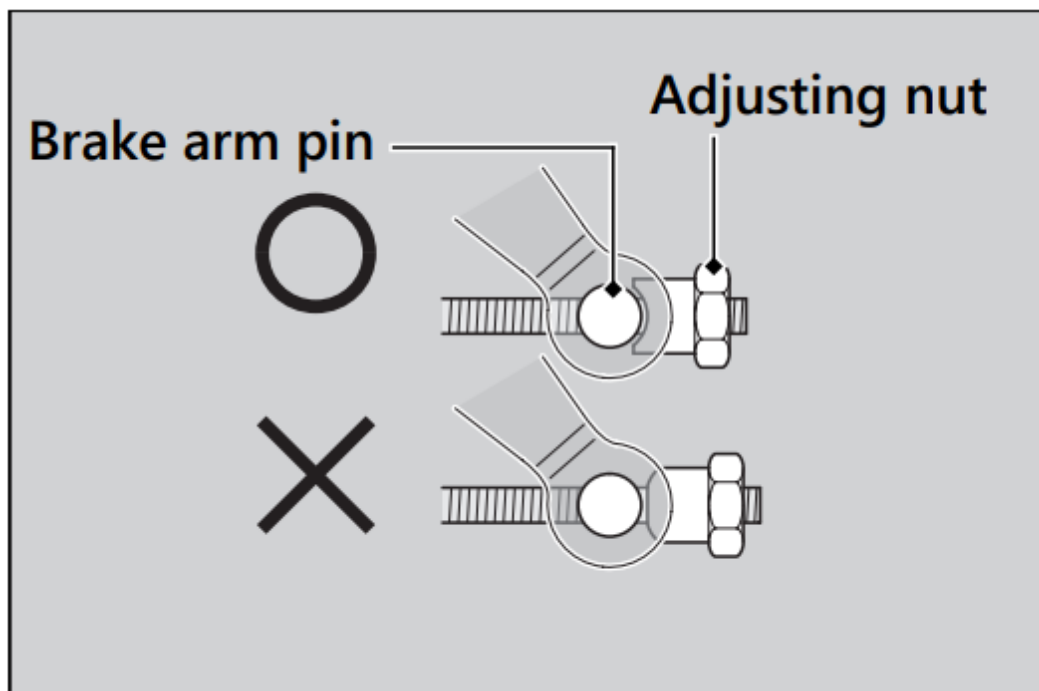

If proper adjustment cannot be obtained by this method, see your dealer.

1. Adjust by turning the rear brake adjusting nut a half-turn at a time

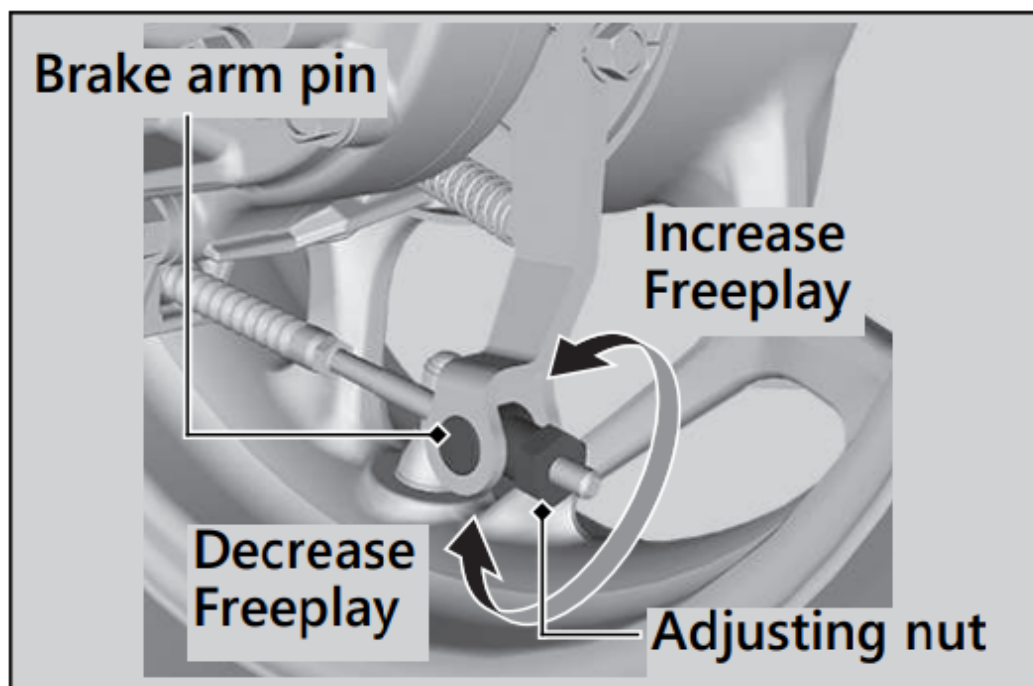

2. Apply the brake several times and check for free wheel rotation after the brake lever is released.
3. Push the brake arm to confirm that there is a gap between the rear brake adjusting nut and brake arm pin

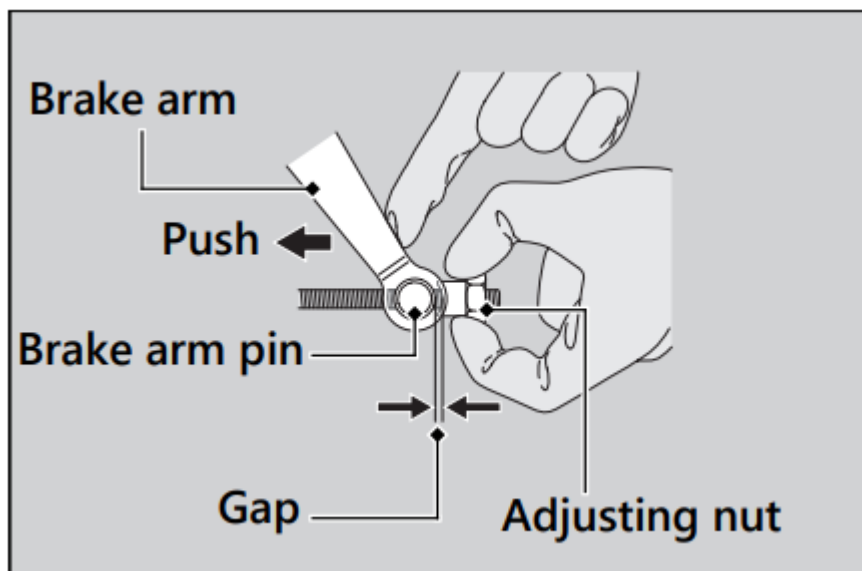

After adjustment, confirm the freeplay of the brake lever.

Make sure the brake arm, spring and fastener are in good condition.

### Inspecting the Rear Brake Shoe Wear

The rear brake is equipped with a brake wear indicator.

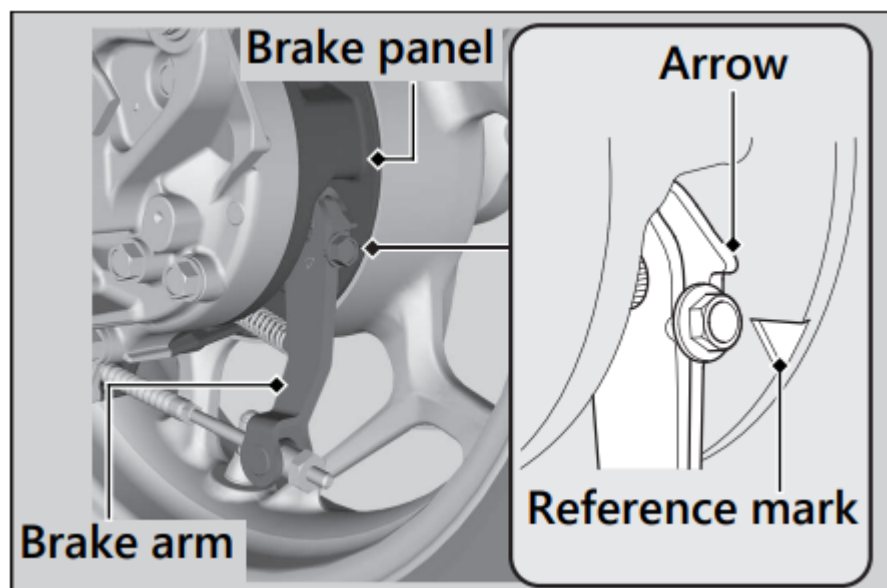

When the brake is applied, an arrow attached to the brake arm moves toward a reference mark on the brake panel. If the arrow aligns with the reference mark on full application of the brake, the brake shoes must be replaced. See your dealer for this service.

When brake service is necessary, see your dealer. Use only Honda Genuine Parts or their equivalent.

### Side Stand

## Checking the Side Stand

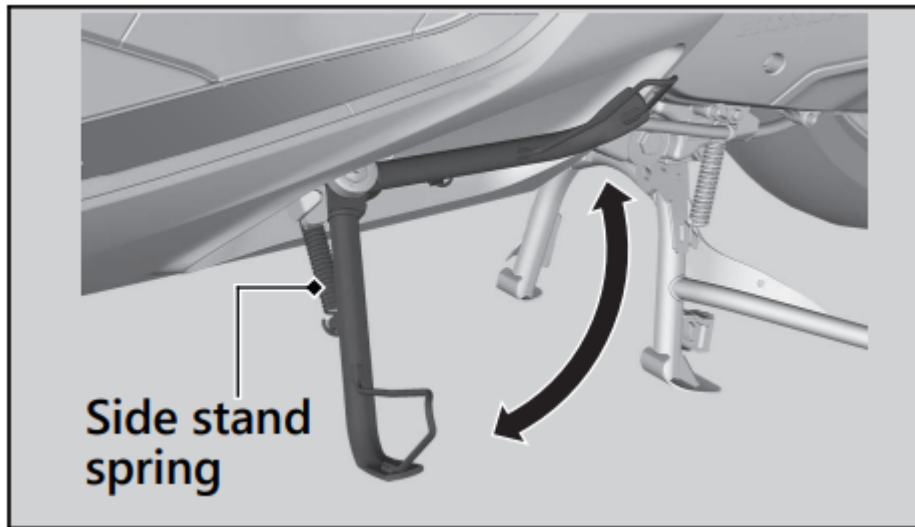

1. Place your vehicle on its center stand on a firm, level surface.
2. Check that the side stand operates smoothly. If the side stand is stiff or squeaky, clean the pivot area and lubricate the pivot bolt with clean grease.
3. Check the spring for damage or loss of tension.
4. Sit on the vehicle and raise the side stand.
5. Start the engine.
6. Lower the side stand all the way. The engine should stop as you lower the side stand. If the engine doesn't stop, have your vehicle inspected by your dealer.

## Throttle

With the engine off, check that the throttle rotates smoothly from fully closed to fully open in all steering positions and throttle freeplay is correct. If the throttle does not move smoothly, close automatically, or if the cable is damaged, have the vehicle inspected by your dealer.

## Freeplay at the throttle grip flange:

1/16 - 1/4 in (2 - 6 mm)

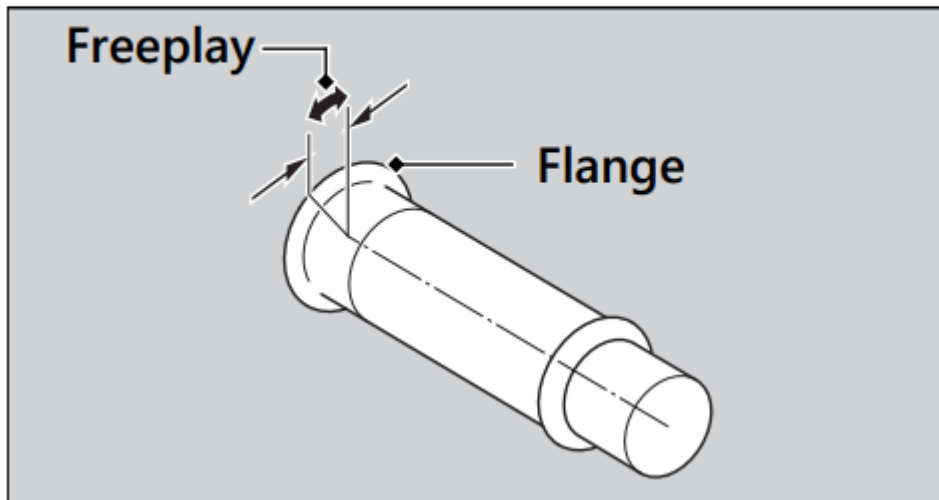

## Troubleshooting

### Engine Will Not Start

#### Starter Motor Operates But Engine Does Not Start

Check the following items:

- Check the correct engine starting sequence. → P. 43
- Check that there is gasoline in the fuel tank.
- Check if the PGM-FI malfunction indicator lamp (MIL) is on.  
→ If the indicator lamp is on, contact your dealer as soon as possible.

#### Starter Motor Does Not Operate

Check the following items:

- Check the correct engine starting sequence. → P. 43
- Make sure engine stop switch is in the  (Run) position. → P. 36
- Check for a blown fuse. → P. 98
- Check for a loose battery connection (→ P. 75) or battery terminal corrosion (→ P. 66).
- Check the condition of the battery. → P. 97

If the problem continues, have your vehicle inspected by your dealer.

## **Overheating (High coolant temperature indicator is on)**

The engine is overheating when the following occurs:

- High coolant temperature indicator comes on.
- Acceleration becomes sluggish.

If this occurs, pull safely to the side of the road and perform the following procedure. Extended fast idling may cause the high coolant temperature indicator to come on.

1. Stop the engine using the ignition switch.
2. Allow the engine to cool with the ignition switch in the OFF position.
3. After the engine has cooled, inspect the radiator hose and check if there is a leak. → P. 79 If there is a leak: Do not start the engine. Transport your vehicle to your dealer.
4. Check the coolant level in the reserve tank. → P. 79  
→ Add coolant as necessary.
5. If 1-4 check normal, you may continue riding, but closely monitor the high coolant temperature indicator.

## **Warning Indicators On or Flashing**

### **PGM-FI (Programmed Fuel Injection) Malfunction Indicator Lamp (MIL)**

If the indicator comes on while riding, you may have a serious problem with the PGM-FI system. Reduce speed and have your vehicle inspected by your dealer as soon as possible

### **Battery Charging Condition indicator**

If the indicator comes on while riding, you may have a condition of low battery voltage or battery performance degradation. Have your vehicle inspected by your dealer.

→ If the battery does not have enough voltage to power the indicator system, the indicator may not come on.

### **ABS (Anti-lock Brake System) Indicator**

If the indicator operates in one of the following ways, you may have a serious problem with the ABS. Reduce your speed and have your vehicle inspected by your dealer as soon as possible.

- Indicator comes on or starts flashing while riding.
- Indicator does not come on when the ignition switch is in the ON position.

- Indicator does not go off at speeds above 6 mph (10 km/h).

If the ABS indicator stays on, your brakes will continue to work as a conventional system, but without the anti-locking function.

The ABS indicator may flash if you turn the rear wheel while the rear wheel is lifted off the ground. In this case, turn the ignition switch to the OFF position, and then to the ON position again. The ABS indicator will go off after your speed reaches 19 mph (30 km/h).

### **Torque Control Indicator**

If the indicator operates in one of the following ways, you may have a serious problem with the Torque Control. Reduce your speed and have your vehicle inspected by your dealer as soon as possible.

- Indicator comes and stays on (solid) while riding.
- Indicator does not come on when the ignition switch is turned to the ON position.
- Indicator does not go off at speeds above 2 mph (3 km/h)

Even when the Torque Control indicator is on, your vehicle will have normal riding ability without Torque Control function.

→ When the indicator comes on while the Torque Control is in operation, you will have to completely close the throttle to regain normal riding ability.

The Torque Control indicator may come on if you rotate the rear wheel while your vehicle is lifted off the ground. In this case, turn the ignition switch to the OFF position, and then to the ON position again. The Torque Control indicator will go off after your speed reaches 2 mph (3 km/h).

### **Other Warning Indications**

#### **Fuel Gauge Failure Indication**

If the fuel system has an error, the fuel gauge indicators will be displayed as shown in the illustrations.

If this occurs, see your dealer as soon as possible.

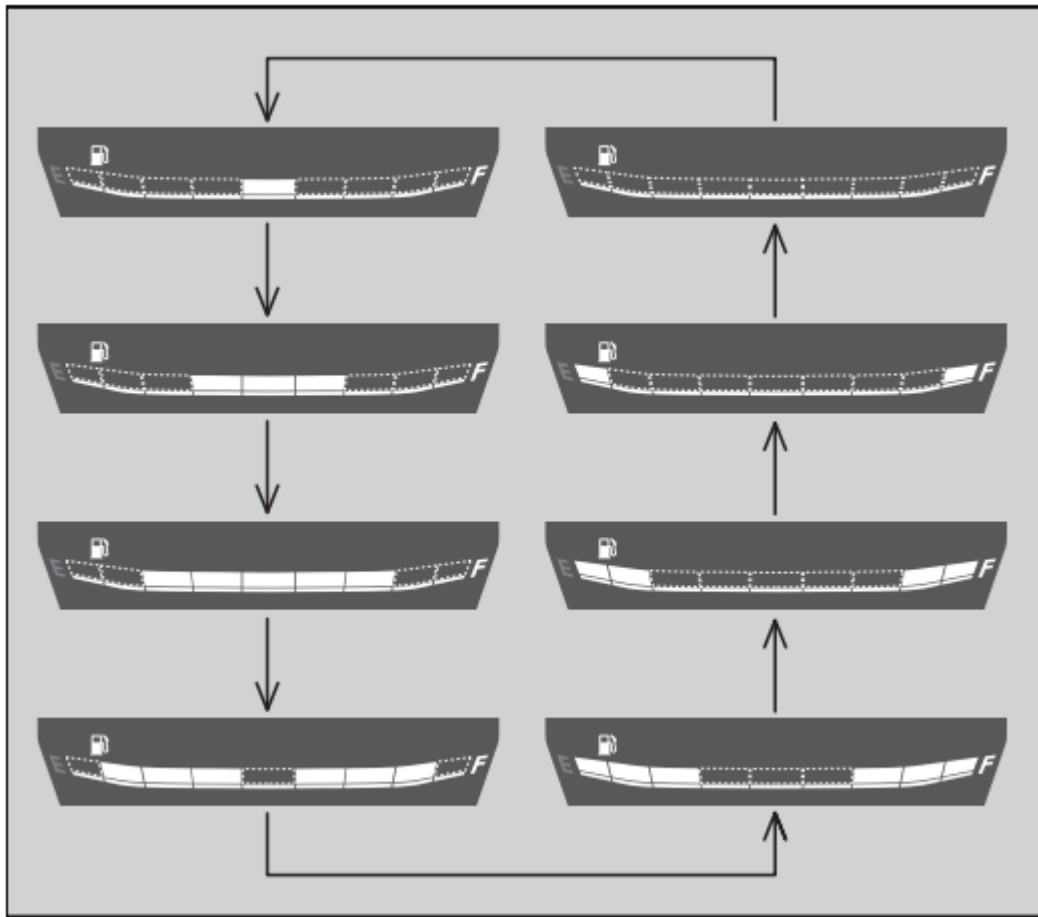

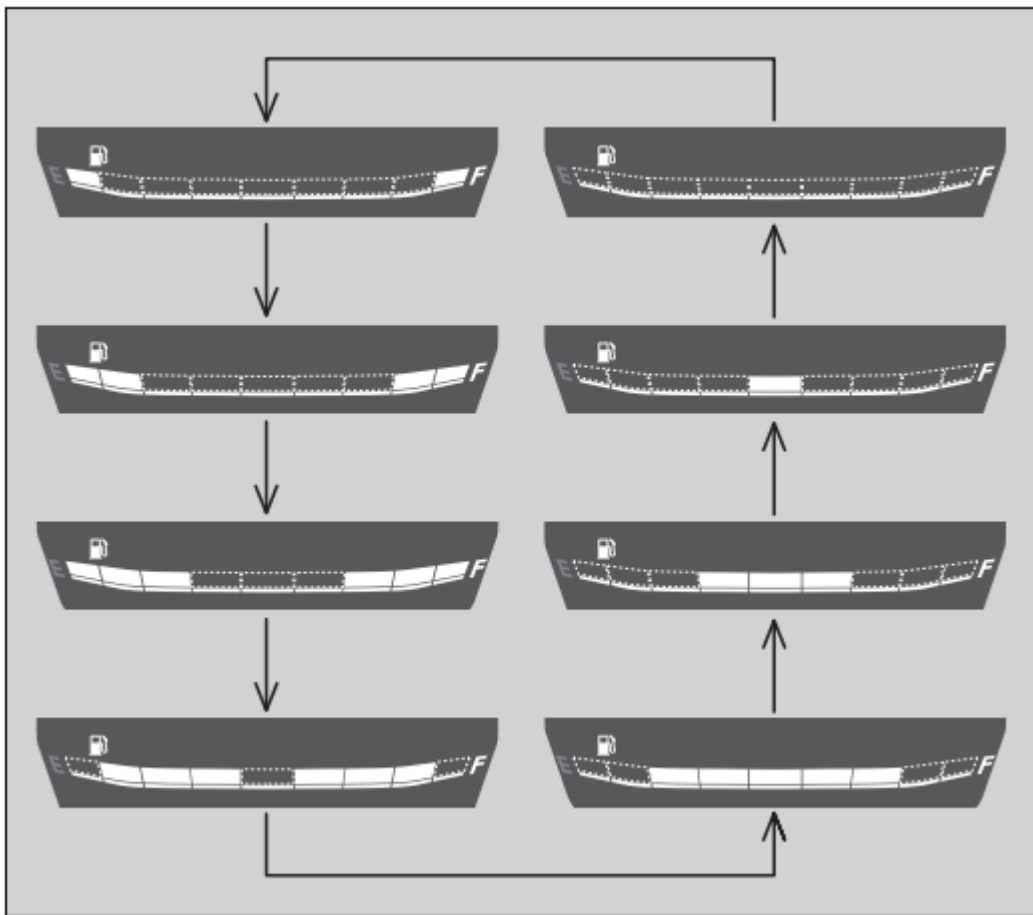

## Tire Puncture

### Emergency Repair Using a Tire Repair Kit

If your tire has a minor puncture, you can make an emergency repair using a tubeless tire repair kit. Follow the instructions provided with the emergency tire repair kit.

Riding your vehicle with a temporary tire repair is very risky. Do not exceed 30 mph (50 km/h). Have the tire replaced by your dealer as soon as possible.

## Electrical Trouble

### Battery Goes Dead

Charge the battery using a motorcycle battery charger. Remove the battery from the vehicle before charging. Do not use an automobile-type battery charger, as these can overheat a motorcycle battery and cause permanent damage. If the battery does not recover after recharging, contact your dealer.

### Burned-out Light Bulb

All light bulbs on the vehicle are LEDs. If any of the LED lights do not turn on, see your dealer for servicing.

### Blown Fuse

## Fuse Box Fuses

1. Remove the battery cover. → P. 76
2. Remove the fuse box cover.
3. Pull the main fuse and other fuses out one by one with the fuse puller located inside of the fuse box cover. Check for a blown fuse. Always replace a blown fuse with a spare fuse of the same rating.
4. Install the fuse box cover.
5. Install the battery cover.

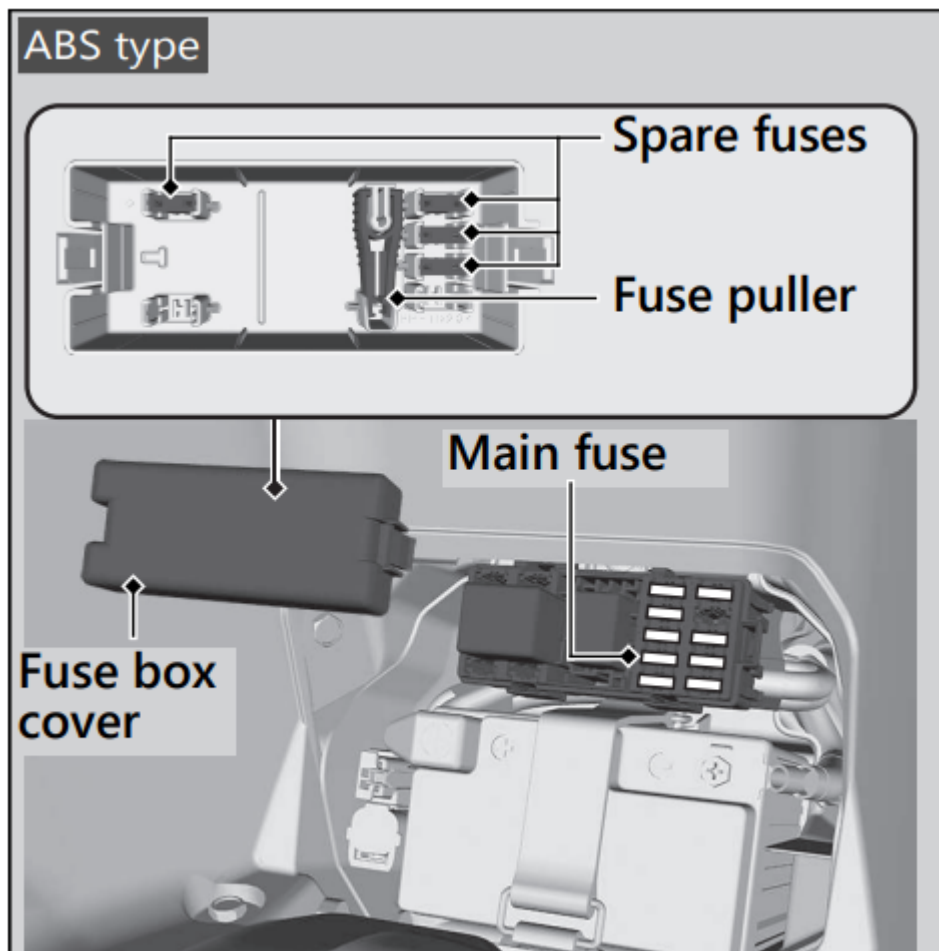

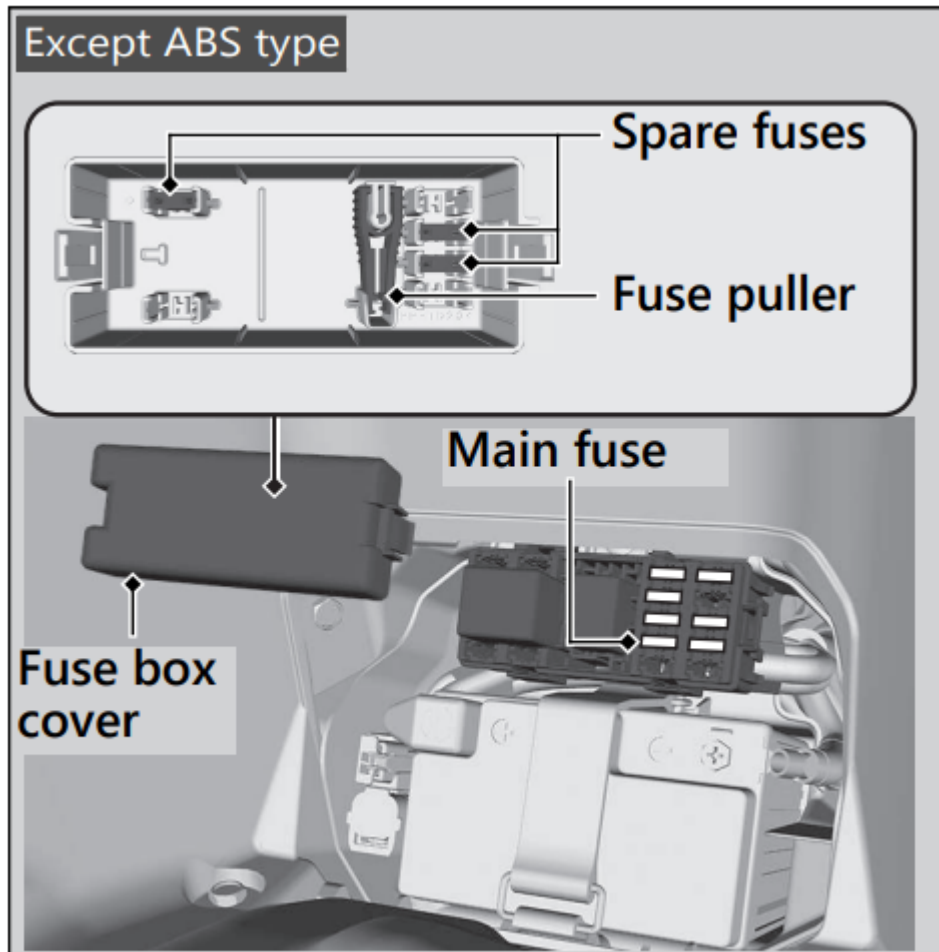

### Unstable Engine Operation Occurs Intermittently

If the fuel pump filter is clogged, unstable engine operation will occur intermittently while riding.

Even if this symptom occurs, you can continue to ride your vehicle.

If unstable engine operation occurs even if sufficient fuel is available, have your vehicle inspected by your dealer as soon as possible.

## Specifications

### ■ Main Components

Overall length	76.2 in (1,935 mm)	
Overall width	29.1 in (740 mm)	
Overall height	43.5 in (1,105 mm)	
Wheelbase	51.8 in (1,315 mm)	
Minimum ground clearance	5.3 in (135 mm)	
Caster angle	26° 30'	
Trail	3.1 in (80 mm)	
Curb weight	<b>ABS type</b>	287 lb (130 kg)
	<b>Except ABS type</b>	289 lb (131 kg)
Maximum weight capacity *1	366 lb (166 kg)	
Maximum luggage weight	Center compartment	22 lb (10 kg)
	Front box	2.0 lb (1.0 kg)
Passenger capacity	Rider and 1 passenger	
Minimum turning radius	6.2 ft (1.90 m)	
Displacement	9.6 cu-in (157 cm <sup>3</sup> )	
Bore x stroke	2.36 x 2.19 in (60.0 x 55.5 mm)	
Compression ratio	12.0:1	
Fuel	Unleaded gasoline Recommended fuel octane number: Pump Octane Number (PON) 86 or higher	
Tank capacity	2.14 US gal (8.1 L)	
Battery	GTZ8V 12 V-7.0 Ah (10 HR)	
Primary reduction	V-Matic (2.52:1-0.81:1)	
Final reduction	9.589	



\*1 : Including rider, passenger, all luggage, and accessories.

■ Service Data

Tire size	Front	110/70-14M/C 50P
	Rear	130/70-13M/C 63P
Tire type	Bias-ply, tubeless	
Recommended Tires	Front	IRC SCT-006
	Rear	IRC SCT-007
Tire air pressure (With less than 200 lb (90 kg) of added weight)	Front	29 psi (200 kPa, 2.00 kgf/cm <sup>2</sup> )
	Rear	33 psi (225 kPa, 2.25 kgf/cm <sup>2</sup> )

Tire air pressure (With more than 200 lb (90 kg) of added weight)	Front	29 psi (200 kPa, 2.00 kgf/cm <sup>2</sup> )
	Rear	36 psi (250 kPa, 2.50 kgf/cm <sup>2</sup> )

Minimum tread depth	Front	0.06 in (1.5 mm)
	Rear	0.08 in (2.0 mm)

Spark plug	(standard)	LMAR8L-9 (NGK)
------------	------------	----------------

Spark plug gap	0.03 - 0.04 in (0.8 - 0.9 mm)	
----------------	-------------------------------	--

Idle speed	(non-adjustable)	1,700 ± 100 rpm
------------	------------------	-----------------

Recommended engine oil API Service Classification SJ or higher except oils labeled as energy conserving or resource conserving on the circular API service label, SAE10W-30, JASO T 903 standard MB, Pro Honda HP4M 4-stroke oil or an equivalent motorcycle oil



Engine oil capacity	After draining	0.8 US qt (0.8 L)
	After draining & cleaning strainer screen	0.90 US qt (0.85 L)
	After disassembly	1.0 US qt (0.9 L)
Transmission oil capacity	After draining	0.13 US qt (0.12 L)
	After disassembly	0.15 US qt (0.14 L)

Recommended brake fluid	Honda DOT 3 or DOT 4 Brake Fluid
Cooling system capacity	0.53 US qt (0.50 L)
Recommended coolant	Pro Honda HP Coolant

■ **Bulbs**

Headlight	LED
Brake light/Taillight	LED
Front turn signal	LED
Rear turn signal	LED
License plate light	LED
Position lights	LED

■ **Fuses**

Main fuse	30 A	
Other fuse	<b>ABS type</b>	15 A, 10 A, 7.5 A
	<b>Except ABS type</b>	10 A, 7.5 A



**Warning**

This content is compiled from multiple sources and is provided for reference purposes only. It may not be complete or fully applicable to all situations. If you are unable to resolve your issue, please contact the product manufacturer or an authorized service provider for official support.

---

Document generated by [ManualsFile](#)