

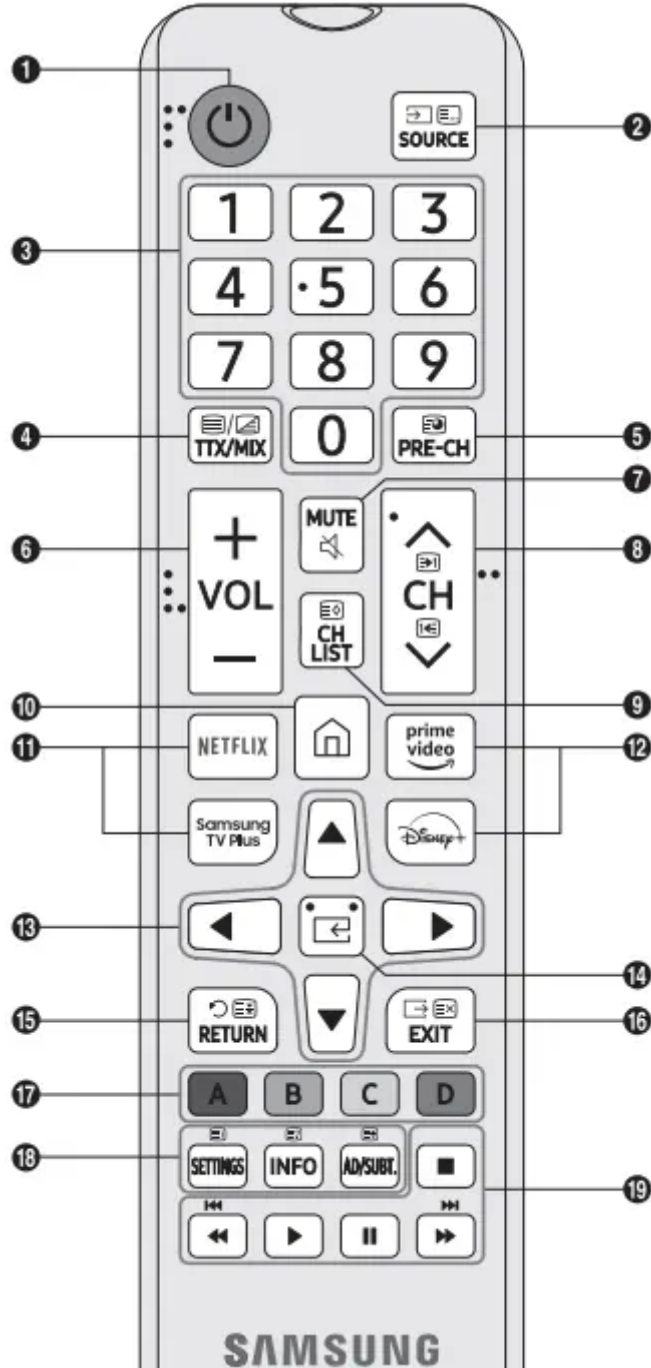

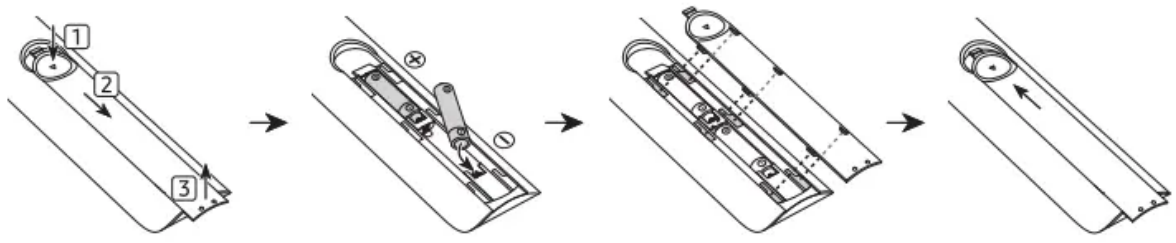







## Remote Control

### About the Buttons on the Standard Remote Control





Button	Description
 (Power)	<p>Press to turn the TV on or off.</p> <p>For The Frame model, When watching TV, press to switch to <b>Art</b> mode. In <b>Art</b> mode, press to switch to the <b>Media</b> Home. Press and hold to turn off the TV completely.</p>
 MIC/LED	<p>Used as MIC when using voice recognition with the remote control.</p> <p>When charging the remote control via the USB port, the LED is lit if charging is in progress. When charging is complete, the LED is turned off.</p> <ul style="list-style-type: none"> <li>• Do not impact the MIC hole or use a sharp object to poke into the hole.</li> </ul>
 (Voice Assistant)	<p>Runs Voice Assistant. Press and hold the button, say a command, and then release the button to run Voice Assistant.</p> <ul style="list-style-type: none"> <li>• The supported Voice Assistant's languages and features may differ by geographical area.</li> </ul>
 (Settings / Number / Option button)	<p>Each time you press this button, Settings menu / virtual numeric pad / Option pad are displayed alternately.</p> <ul style="list-style-type: none"> <li>• Use this button to access additional options that are specific to the feature in use.</li> <li>• Press to bring up the virtual numeric pad on the screen. Use the numeric keypad to enter numeric values. Select numbers and then select <b>Done</b> or <b>Enter Number</b> to enter a numeric value. Use to change the channel, enter a PIN, ZIP code and etc.</li> <li>• When pressed for a second or more, the <b>Shortcuts</b> menu screen appears.</li> </ul>
 (Colour button)	<p>When pressed, coloured buttons appear on the screen. Use this button to access additional options that are specific to the feature in use.</p>



<p><b>2</b> Directional button (up, down, left, right)</p>	<p>Moves the focus and changes the values seen on the TV's menu.</p>
<p><b>3</b> Select</p>	<p>Selects or runs a focused item. When pressed while you are watching a broadcast programme, detailed programme information appears.</p>
<p> (Return)</p>	<p>Press to return to the previous menu. When pressed for a second or more, the running function is terminated. When pressed while you are watching a programme, the previous channel appears.</p>
<p> (Smart Hub)</p>	<p>Press to switch to the <b>Media</b> Home. For The Frame model, in <b>Art</b> mode, press to switch to the <b>Art</b> Home.</p>
<p> (Play/pause)</p>	<p>When pressed, the playback controls appear. Using these controls, you can control the media content that is playing.</p>
<p>+/- (Volume)</p>	<p>Move the button up or down to adjust the volume. To mute the sound, press the button. When pressed for 2 seconds or more, the <b>Accessibility Shortcuts</b> appears.</p>
<p>^ / v (Channel)</p>	<p>Move the button up or down to change the channel. To see the <b>Guide</b> screen, press the button.</p> <ul style="list-style-type: none"> <li>• When pressed for a second or more, the <b>Channel List</b> screen appears.</li> </ul>
<p><b>4</b> Launch app button</p>	<p>Press each button to run its function</p> <ul style="list-style-type: none"> <li>• Available apps may differ depending on the geographical area or contents provider.</li> </ul>
<p> (Pairing)</p>	<p>If the Samsung Smart Remote does not pair to the TV automatically, point it at the front of the TV, and then press and</p>

hold the  and  buttons simultaneously for 3 seconds or more.

- Use the Samsung Smart Remote less than 6 m from the TV. The usable distance may vary with the wireless environmental conditions.
- The images, buttons, and functions of the Samsung Smart Remote may differ with the model or geographical area.
- The Universal Remote function operates normally only when you use the Samsung Smart Remote that comes with the TV. (This function may not be supported depending on the model.)
- It is recommended to use an original Samsung charger. Otherwise, it may cause performance degradation or failure of the product. In this case, the warranty service is not applicable.
- When the remote control does not work due to low battery, charge it by using the USB-C type port.

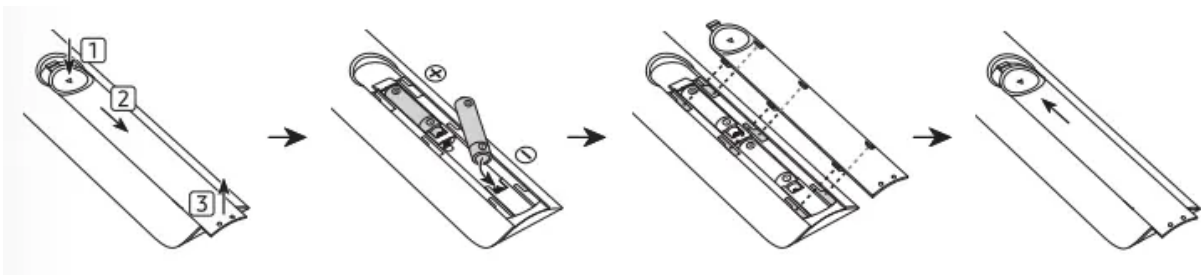
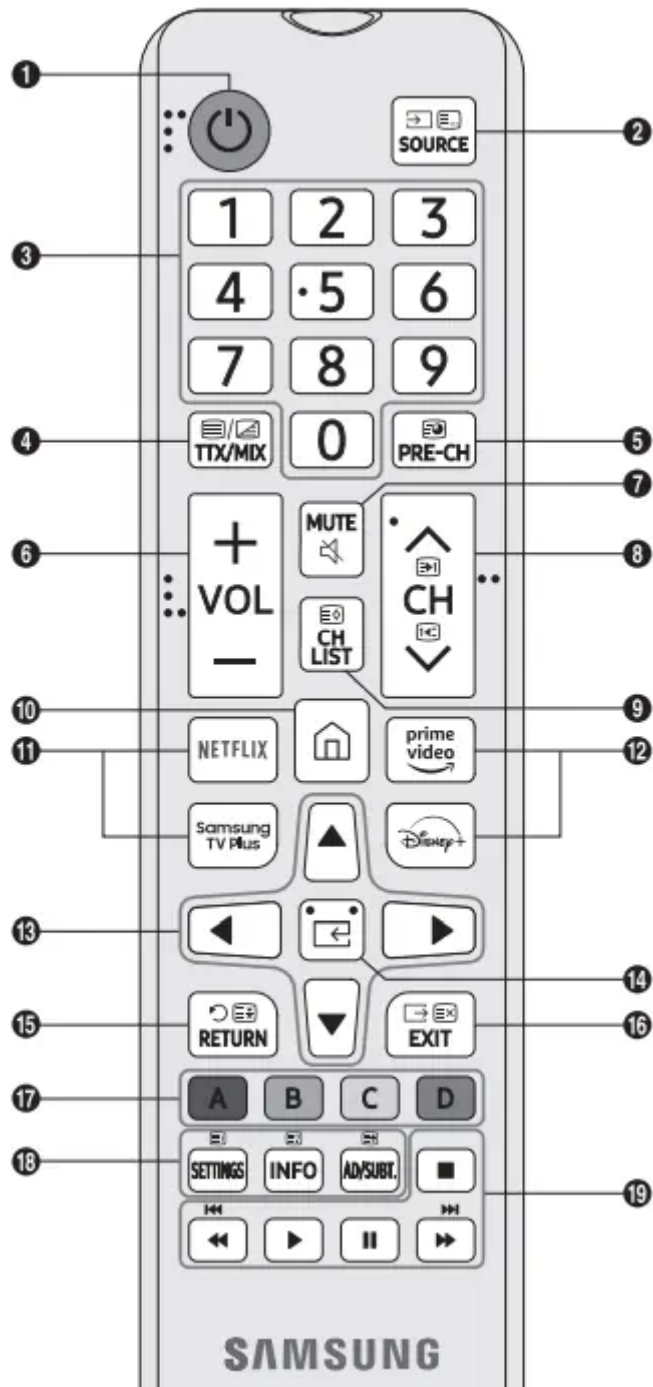
#### **About the Buttons on the Standard Remote Control**



Number	Description
1	 <b>(Power)</b> Turns the TV on and off.
2	Displays and selects available video sources.
3	Gives direct access to channels.
4	Alternately selects Teletext mode, <b>Full TTX / Double TTX / Mix / Live TV.</b>
5	Returns to the previous channel.
6	Adjusts the volume.
7	Turns the sound on/off.
8	Changes the current channel.
9	Launches the <b>Channel List.</b>
10	Press to switch to the <b>Media Home.</b>
11, 12	Press each button to run its function. <ul style="list-style-type: none"> <li>• Available apps may differ depending on the geographical area or contents provider.</li> </ul>
13	Moves the cursor, selects the on-screen menu items, and changes the values seen on the TV's menu.
14	 <b>3 (Select)</b> Selects or runs a focused item.

15	Returns to the previous menu or channel.
16	Exits the menu.
17	Use these buttons according to the directions on the TV screen.
18	<p><b>SETTINGS</b></p> <p>Displays the main on-screen menu.</p> <p><b>INFO</b></p> <p>Displays information about the current programme or content. <b>AD/SUBT.</b></p> <p>Displays the <b>Accessibility Shortcuts.</b></p>
19	Use these buttons with specific features. Use these buttons according to the directions on the TV screen.

- The images, buttons, and functions of the remote control may differ depending on the model.
- This remote control has Braille points on the Power, Channel, Volume, and Select buttons and can be used by visually impaired persons.
- If you use the remote control that comes with your TV to control another TV, some functions may not operate normally

## Initial Setup

When you turn on your TV for the first time, it immediately starts the Initial Setup. Follow the instructions displayed on the screen and configure the TV's basic settings to suit your viewing environment.

### Using the TV Controller

You can turn on the TV with the TV Controller button at the bottom of the TV, and then use the Control menu. The Control menu appears when the TV Controller button is pressed while the TV is On.

- The screen may dim if the protective film on the SAMSUNG logo or the bottom of the TV is not detached. Please remove the protective film.

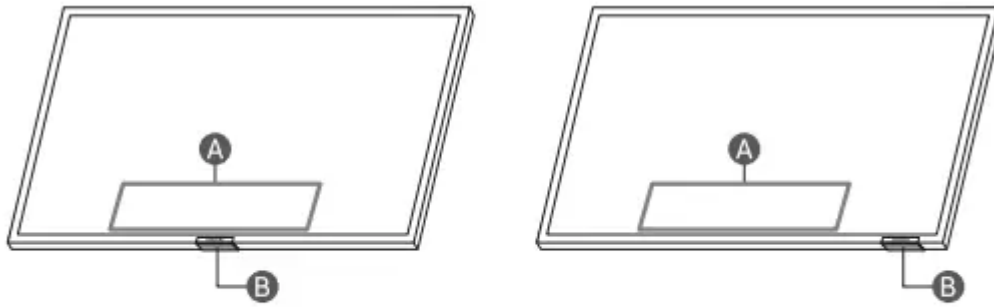

**A** Control menu

**B** TV Controller button / Remote control sensor

### **Setting the sound sensor**

- This function is supported only in Q7\*B/Q8\*B/ QN8\*B/QN9\*B Series.

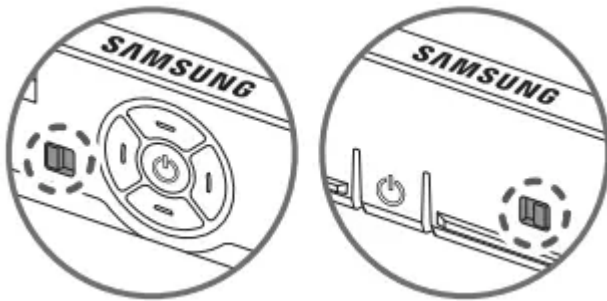

You can turn on or off the sound sensor by using its button at the bottom of the TV.

With the TV on, you can push the button to the left (or backward) to turn on the sound sensor or to the right (or forward) to turn off it. See the pop-up window on the TV to check whether the sound sensor is turned on or off.

- The position and shape of the sound sensor may differ depending on the model.
- During analysis using data from the sound sensor, the data is not saved.

### **Caring for the TV**

- To clean this apparatus, unplug the power cable from the wall outlet and wipe the product with a soft, dry cloth. Do not use any chemicals such as wax, benzene, alcohol, thinners, insecticide, aerial fresheners, lubricants, or detergents. These chemicals can damage the appearance of the TV or erase the printing on the product.
- The exterior and screen of the TV can get scratched during cleaning. Be sure to wipe the exterior and screen carefully using a soft cloth to prevent scratches.
- Do not spray water or any liquid directly onto the TV. Any liquid that goes into the product may cause a failure, fire, or electric shock.

## Troubleshooting and Maintenance

For more information, refer to "Troubleshooting" or "FAQ" in the e-Manual.

**Home > Menu > Settings > Support > Open e-Manual > Troubleshooting or FAQ**



If none of the troubleshooting tips apply, please visit "www. samsung.com" and click Support or contact the Samsung service centre.

- This TFT LED panel is made up of sub pixels which require sophisticated technology to produce. There may be, however, a few bright or dark pixels on the screen. These pixels will have no impact on the performance of the product.
- To keep your TV in optimum condition, upgrade to the latest software. Use the Update Now or Auto update functions on the TV's menu (**Home > Menu > Settings > Support > Software Update > Update Now or Auto update**).

### The TV won't turn on.

- Make sure that the power cable is securely plugged in to the TV and the wall outlet.
- Make sure that the wall outlet is working and the remote control sensor at the bottom of the TV is lit and glowing a solid red.
- Try pressing the TV Controller button at the bottom of the TV to make sure that the problem is not with the remote control. If the TV turns on, refer to "The remote control does not work".

### The remote control does not work.

- Check if the remote control sensor at the bottom of the TV blinks when you press the  button on the remote control.
  - Samsung Smart Remote: When the remote's battery is discharged, charge the battery using the USB charging port (C-type), or turn over the remote to expose the solar cell to light.
  - Standard Remote Control: If it does not blink, replace the remote control's batteries. Make sure that the batteries are installed with their poles (+/-) in the correct direction. Alkaline batteries are recommended for longer battery life.
- Try pointing the remote directly at the TV from 1.5-1.8 m away.
- If your TV came with a Samsung Smart Remote (Bluetooth Remote), make sure to pair the remote to the TV. To pair a Samsung Smart Remote, press the  and  buttons together for 3 seconds.

## Eco Sensor and screen brightness

Eco Sensor adjusts the brightness of the TV automatically. This feature measures the light in your room and optimises the brightness of the TV automatically to reduce power consumption. If you want to turn this off, go to **Home > Menu > Settings > All Settings > General & Privacy > Power and Energy Saving > Brightness Optimisation**.

- The eco sensor is located at the bottom of the TV. Do not block the sensor with any object. This can decrease picture brightness.

## Important Safety Instructions

### Power

- Do not overload wall outlets, extension cords, or adaptors beyond their voltage and capacity. It may cause fire or electric shock. Refer to the power specifications section of the manual and/or the power supply label on the product for voltage and amperage information.
- Power-supply cords should be placed so that they are not likely to be walked on or pinched by items placed upon or against them. Pay particular attention to cords at the plug end, at wall outlets, and at the point where they exit from the appliance
- Never insert anything metallic into the open parts of this apparatus. This may cause electric shock.
- To avoid electric shock, never touch the inside of this apparatus. Only a qualified technician should open this apparatus.
- Be sure to plug in the power cable until it is firmly seated. When unplugging the power cable from a wall outlet, always pull on the power cable's plug. Never unplug it by pulling on the power cable. Do not touch the power cable with wet hands.
- If this apparatus does not operate normally - in particular, if there are any unusual sounds or smells coming from it - unplug it immediately and contact an authorised dealer or Samsung service centre.
- To protect this apparatus from a lightning storm, or to leave it unattended and unused for a long time, be sure to unplug it from the wall outlet and disconnect the antenna or cable system.
  - Accumulated dust can cause an electric shock, an electric leakage, or a fire by causing the power cable to generate sparks and heat or by causing the insulation to deteriorate.

- Use only a properly grounded plug and wall outlet.
  - An improper ground may cause electric shock or equipment damage. (Class I Equipment only.)
- To turn off this apparatus completely, disconnect it from the wall outlet. To ensure you can unplug this apparatus quickly if necessary, make sure that the wall outlet and power plug are readily accessible.

## Installation

- Do not place this apparatus near or over a radiator or heat register, or where it is exposed to direct sunlight.
- Do not place vessels (vases etc.) containing water on this apparatus, as this can result in a fire or electric shock.
- Do not expose this apparatus to rain or moisture.
- Be sure to contact an authorised Samsung service centre for information if you intend to install your TV in a location with heavy dust, high or low temperatures, high humidity, chemical substances, or where it will operate 24 hours a day such as in an airport, a train station, etc. Failure to do so may lead to serious damage to your TV.
- Do not expose this apparatus to dripping or splashing.

## Operation

- This apparatus uses batteries. In your community, there might be environmental regulations that require you to dispose of these batteries properly. Please contact your local authorities for disposal or recycling information.
- Store the accessories (remote control, batteries, or etc.) in a location safely out of the reach of children.
- Do not drop or strike the product. If the product is damaged, disconnect the power cable and contact a Samsung service centre.
- Do not dispose of remote control or batteries in a fire.
- Do not short-circuit, disassemble, or overheat the batteries.
- CAUTION: There is danger of an explosion if you replace the batteries used in the remote with the wrong type of battery. Replace only with the same or equivalent type.
- WARNING - TO PREVENT THE SPREAD OF FIRE, KEEP CANDLES AND OTHER ITEMS WITH OPEN FLAMES AWAY FROM THIS PRODUCT AT ALL TIMES.

### Warning

This content is compiled from multiple sources and is provided for reference purposes only. It may not be complete or fully applicable to all situations. If you are unable to resolve your issue, please contact the product manufacturer or an authorized service provider for official support.

---

Document generated by [ManualsFile](#)