

IMPORTANT SAFEGUARDS

1. The appliance is for indoor use only
2. Do not use the unit on a socket under repairs or not installed properly. Make sure the plug is plugged firmly and completely into the outlet. It can result in the risk of electric shock or fire.
3. Do not use the unit, follow these precautions
 - A: Near to source of fire
 - B: An area where oil is likely to splash
 - C: An area exposed to direct sunlight
 - D: An area where water is likely to splash
 - E: Near a bath, a laundry, a shower or a swimming pool
4. Never insert your fingers, rods into the air outlet. Take special care to warn children of these dangers
5. Always transport your appliance in a vertical position and place on a stable, level surface during use, for the compressor locates properly
6. Before cleaning the air-conditioner, always turn off or disconnect the power supply.

Do not use hazardous chemicals to clean or come into contact with the unit. To prevent damage to the surface finish, use only a soft cloth to clean the appliance. Do not use wax, thinner, or a strong detergent. Do not use the unit in the presence of inflammable substance or vapour such as alcohol, insecticides, gasoline, etc.
7. When moving the air-conditioner, always turn off and disconnect the power supply, and move it slowly.
8. To avoid the possibility of fire disaster, the air-conditioner shall not be covered
9. All the air-conditioner sockets must comply with the local electric safety requirements. If necessary, please check it for the requirements
10. Children should be supervised to ensure that they do not play with the appliance
11. If the supply cord is damaged, it must be replaced by the manufacturer, its service agent or similarly qualified persons in order to avoid a hazard
12. This appliance is not intended for use by persons (including children) with reduced physical, sensory or mental capabilities, or lack of experience and knowledge, unless they have been given supervision or instruction concerning use of the appliance by a person responsible for their safety.

13. Recycling

The appliance is recommended not to pierce the cooling circuit of the machine. At the end of its useful life, deliver the appliance to a special waste collection centre for disposal.

this product should not be disposed with other household wastes . To prevent possible harm to the environment or human health from uncontrolled waste disposal, recycle it responsibly to promote the sustainable reuse of material resources. To return your used device, please use the return and collection systems or contact the retailer where the product was purchased. They can take this product for environmental safe recycling.

14. Contact authorized service technician for repair or maintenance of this unit

15. Do not pull, deform, or modify the power supply cord, or immerse it in water. Pulling or misuse of the power supply cord can result in damage to the unit and cause electrical shock

16. Compliance with national gas regulations shall be observed

17. Keep ventilation openings clear of obstruction

18. Any person who is involved with working on or breaking into a refrigerant circuit should hold a current valid certificate from an industry-accredited assessment authority, which authorizes their competence to handle refrigerants safely in accordance with an industry recognized assessment specification

19. Servicing shall only be performed as recommended by the equipment manufacturer.

Maintenance and repair requiring the assistance of other skilled personnel shall be carried out under the supervision of the person competent in the use of flammable refrigerants.

20. Do not operate or stop the unit by inserting or pulling out Die power plug, it may cause electric shock or fire due to heat generation.

21. Unplug the unit if strange sounds, smell, or smoke comes from it.

22. If any parts damage, please contact the dealer or a designated repair shop.

23. In case of any damage, please turn off the air switch, disconnect the power supply, and contact the dealer or a designated repair shop.

24. This unit is equipped with a cord that has a earthed wire connected to an earthed pin or grounding tab. The plug must be plugged into a socket that is properly installed and earthed. Do not under any circumstances cut or remove the earthed pin or grounding tab from this plug.

25. To avoid the possibility of danger ,if power cord is damaged,Please turn off the air switch disconnect the power supply,It must be replaced from the dealer or a designated repair shop.

WARNING:

Do not use means to accelerate the defrosting process or to clean, other than those recommended by the manufacturer.

The appliance shall be stored in a room without continuously operating ignition sources (for example: open flames, an operating gas appliance or an operating electric heater).

Do not pierce or burn.

Be aware that refrigerants may not contain an odour.

- If refrigerant gas leaks during installation, ventilate the area immediately. Toxic gas may be produced if the refrigerant comes into contact with fire.
- After completing installation, check for refrigerant gas leakage. Toxic gas may be produced if the refrigerant gas leaks into the room and comes into contact with a source of fire, such as a fan heater, stove or cooker.
- Install personnel and air conditioners to eliminate static electricity during air conditioning installation.
- When installing or relocating the air conditioner, be sure to bleed the refrigerant circuit to ensure it is free of air, and use only the specified refrigerant (R32). The presence of air or other foreign matter in the refrigerant circuit causes abnormal pressure rise, which may result in equipment damage and even injury.

WARNING:

- keep any required ventilation openings clear of obstruction; servicing shall be performed only as recommended by the manufacturer;
- The appliance shall be stored in a well-ventilated area where the room size corresponds to the room area as specified for operation;
- The appliance shall be stored in a room without continuously operating open flames (for example an operating gas appliance) and ignition sources (for example an operating electric heater).
- The appliance shall be stored so as to prevent mechanical damage from occurring.

Specific information regarding appliances with R32 refrigerant gas

- Thoroughly read all of the warnings.
- When defrosting and cleaning the appliance, do not use any tools other than those recommended by the manufacturing company.
- The appliance must be placed in an area without any continuous sources of ignition (for example: open flames, gas or electrical appliances in operation).
- Do not puncture and do not burn.
- The appliance must be installed, used and stored in an area that is greater than 13 m².

- R32 is a refrigerant gas that complies with the European directives on the environment. Do not puncture any part of the refrigerant circuit.
- If the appliance is installed, operated or stored in a non-ventilated area, the room must be designed to prevent the accumulation of refrigerant leaks resulting in a risk of fire or explosion due to ignition of the refrigerant caused by electric heaters, stoves, or other sources of ignition.
- The appliance must be stored in such a way as to prevent mechanical failure.
- Individuals who operate or work on the refrigerant circuit must have the appropriate certification issued by an accredited organization that ensures competence in handling refrigerants according to a specific evaluation recognized by associations in the industry.
- Repairs must be performed based on the recommendations from the manufacturing company.
- Maintenance and repairs that require the assistance of other qualified personnel must be performed under the supervision of an individual specified in the use of flammable refrigerants.
- Do not use means to accelerate the defrosting process or to clean, other than those recommended by the manufacturer.
- The appliance shall be stored in a room without continuously operating open flames (for example an operating gas appliance) or other potential ignition sources (for example an operating electric heater, hot surfaces).
- All the work men who are engaging in the refrigeration system should bear the valid certification awarded by the authoritative organization and the qualification for dealing with the refrigeration system recognized by this industry. If it needs other technician to maintain and repair the appliance, they should be supervised by the person who bears the qualification for using the flammable refrigerant.
- Be aware that the refrigerants may not contain an odour.
- Compliance with national gas regulations shall be observed.
- Keep ventilation openings clear of obstruction.
- A warning that the appliance shall be stored in a well-ventilated area where the room size corresponds to the room area as specified for operation.
- Any person who is involved with working on or breaking into a refrigerant circuit should hold a current valid certificate from an industry-accredited assessment authority, which authorizes their competence to handle refrigerants safely in accordance with an industry recognized assessment specification.

DD.3 Information on servicing

DD.3.1 Checks to the area

Prior to beginning work on systems containing FLAMMABLE REFRIGERANTS, safety checks are necessary to ensure that the risk of ignition is minimised. For repair to the refrigerating system, DD.3.3 to DD.3.7 shall be completed prior to conducting work on the system.

DD.3.2 Work procedure

Work shall be undertaken under a controlled procedure so as to minimise the risk of a flammable gas or vapour being present while the work is being performed.

DD.3.3 General work area

All maintenance staff and others working in the local area shall be instructed on the nature of work being carried out. Work in confined spaces shall be avoided. The area around the workspace shall be sectioned off. Ensure that the conditions within the area have been made safe by control of flammable material.

DD.3.4 Checking for presence of refrigerant

The area shall be checked with an appropriate refrigerant detector prior to and during work, to ensure the technician is aware of potentially toxic or flammable atmospheres. Ensure that the leak detection equipment being used is suitable for use with all applicable refrigerants, i.e. non-sparking, adequately sealed or intrinsically safe.

DD.3.5 Presence of fire extinguisher

If any hot work is to be conducted on the refrigeration equipment or any associated parts, appropriate fire extinguishing equipment shall be available to hand. Have a dry powder or CO2 fire extinguisher adjacent to the charging area.

DD.3.6 No ignition sources

No person carrying out work in relation to a refrigeration system which involves exposing any pipe work shall use any sources of ignition in such a manner that it may lead to the risk of fire or explosion. All possible ignition sources, including cigarette smoking, should be kept sufficiently far away from the site of installation, repairing, removing and disposal, during which refrigerant can possibly be released to the surrounding space. Prior to work taking place, the area around the equipment is to be surveyed to make sure that there are no flammable hazards or ignition risks. "No Smoking" signs shall be displayed.

DD.3.7 Ventilated area

Ensure that the area is in the open or that it is adequately ventilated before breaking into the system or conducting any hot work. A degree of ventilation shall continue during the period that the work is carried out. The ventilation should safely disperse any released refrigerant and preferably expel it externally into the atmosphere.

DD.3.8 Checks to the refrigeration equipment

Where electrical components are being changed, they shall be fit for the purpose and to the correct specification. At all times the manufacturer's maintenance and service guidelines shall be followed. If in doubt, consult the manufacturer's technical department for assistance.

The following checks shall be applied to installations using FLAMMABLE REFRIGERANTS:

- the charge size is in accordance with the room size within which the refrigerant containing parts are installed;
- the ventilation machinery and outlets are operating adequately and are not obstructed;
- if an indirect refrigerating circuit is being used, the secondary circuit shall be checked for the presence of refrigerant;
- marking to the equipment continues to be visible and legible. Markings and signs that are illegible shall be corrected;
- refrigeration pipe or components are installed in a position where they are unlikely to be exposed to any substance which may corrode refrigerant containing components, unless the components are constructed of materials which are inherently resistant to being corroded or are suitably protected against being so corroded.

DD.3.9 Checks to electrical devices

Repair and maintenance to electrical components shall include initial safety checks and component inspection procedures. If a fault exists that could compromise safety, then no electrical supply shall be connected to the circuit until it is satisfactorily dealt with. If the fault cannot be corrected immediately but it is necessary to continue operation, an adequate temporary solution shall be used. This shall be reported to the owner of the equipment so all parties are advised.

Initial safety checks shall include:

- that capacitors are discharged: this shall be done in a safe manner to avoid possibility of sparking;
- that no live electrical components and wiring are exposed while charging, recovering or purging the system;
- that there is continuity of earth bonding.

DD.4 Repairs to sealed components

DD.4.1 During repairs to sealed components, all electrical supplies shall be disconnected from the equipment being worked upon prior to any removal of sealed covers, etc. If it is absolutely necessary to have an electrical supply to equipment during servicing, then a permanently operating form of leak detection shall be located at the most critical point to warn of a potentially hazardous situation.

DD.4.2 Particular attention shall be paid to the following to ensure that by working on electrical components, the casing is not altered in such a way that the level of protection is affected. This shall include damage to cables, excessive number of connections, terminals not made to original specification, damage to seals, incorrect fitting of glands, etc.

Ensure that the apparatus is mounted securely.

Ensure that seals or sealing materials have not degraded to the point that they no longer serve the purpose of preventing the ingress of flammable atmospheres. Replacement parts shall be in accordance with the manufacturer's specifications.

NOTE The use of silicon sealant can inhibit the effectiveness of some types of leak detection equipment. Intrinsically safe components do not have to be isolated prior to working on them.

DD.5 Repair to intrinsically safe components

Do not apply any permanent inductive or capacitance loads to the circuit without ensuring that this will not exceed the permissible voltage and current permitted for the equipment in use.

Intrinsically safe components are the only types that can be worked on while live in the presence of a flammable atmosphere. The test apparatus shall be at the correct rating.

Replace components only with parts specified by the manufacturer. Other parts may result in the ignition of refrigerant in the atmosphere from a leak.

DD.6 Cabling

Check that cabling will not be subject to wear, corrosion, excessive pressure, vibration, sharp edges or any other adverse environmental effects. The check shall also take into account the effects of aging or continual vibration from sources such as compressors or fans.

DD.7 Detection of flammable refrigerants

Under no circumstances shall potential sources of ignition be used in the searching for or detection of refrigerant leaks. A halide torch (or any other detector using a naked flame) shall not be used.

DD.8 Leak detection methods

The following leak detection methods are deemed acceptable for all refrigerant systems.

Electronic leak detectors may be used to detect refrigerant leaks but, in the case of FLAMMABLE REFRIGERANTS, the sensitivity may not be adequate, or may need re-calibration. (Detection equipment shall be calibrated in a refrigerant-free area.) Ensure that the detector is not a potential source of ignition and is suitable for the refrigerant used. Leak detection equipment shall be set at a percentage of the LFL of the refrigerant and shall be calibrated to the refrigerant employed, and the appropriate percentage of gas (25 % maximum) is confirmed.

Leak detection fluids are suitable for use with most refrigerants but the use of detergents containing chlorine shall be avoided as the chlorine may react with the refrigerant and corrode the copper pipe-work.

If a leak is suspected, all naked flames shall be removed/extinguished.

If a leakage of refrigerant is found which requires brazing, all of the refrigerant shall be recovered from the system, or isolated (by means of shut off valves) in a part of the system remote from the leak. For appliances containing FLAMMABLE

REFRIGERANTS, oxygen free nitrogen (OFN) shall then be purged through the system both before and during the brazing process.

DD.9 Removal and evacuation

When breaking into the refrigerant circuit to make repairs - or for any other purpose -

conventional procedures shall be used. However, for flammable refrigerants it is important that the best practice is followed since flammability is a consideration. Opening of the refrigeration systems shall not be done by brazing. The following procedure shall be adhered to:

- remove refrigerant;
- purge the circuit with inert gas;
- evacuate;
- purge again with inert gas;
- open the circuit by cutting or brazing.

The refrigerant charge shall be recovered into the correct recovery cylinders. For appliances containing FLAMMABLE REFRIGERANTS, the system shall be “flushed” with OFN to render the unit safe. This process may need to be repeated several times. Compressed air or oxygen shall not be used for purging refrigerant systems.

For appliances containing FLAMMABLE REFRIGERANTS, flushing shall be achieved by breaking the vacuum in the system with OFN and continuing to fill until the working pressure is achieved, then venting to atmosphere, and finally pulling down to a vacuum. This process shall be repeated until no refrigerant is within the system. When the final OFN charge is used, the system shall be vented down to atmospheric pressure to enable work to take place. This operation is absolutely vital if brazing operations on the pipe-work are to take place.

Ensure that the outlet for the vacuum pump is not close to any ignition sources and that ventilation is available.

DD.10 Charging procedures

In addition to conventional charging procedures, the following requirements shall be followed.

- Ensure that contamination of different refrigerants does not occur when using charging equipment. Hoses or lines shall be as short as possible to minimise the amount of refrigerant contained in them.
- Cylinders shall be kept upright.
- Ensure that the refrigeration system is earthed prior to charging the system with refrigerant.
- Label the system when charging is complete (if not already).
- Extreme care shall be taken not to overfill the refrigeration system.

Prior to recharging the system, it shall be pressure-tested with the appropriate purging gas. The system shall be leak-tested on completion of charging but prior to commissioning. A follow up leak test shall be carried out prior to leaving the site

DD.11 Decommissioning

Before carrying out this procedure, it is essential that the technician is completely familiar with the equipment and all its detail. It is recommended good practice that all refrigerants are recovered safely. Prior to the task being carried out, an oil and refrigerant sample shall be taken in case analysis is required prior to re-use of reclaimed refrigerant. It is essential that electrical power is available before the task is commenced.

- a) Become familiar with the equipment and its operation.
- b) Isolate system electrically.
- c) Before attempting the procedure, ensure that:
 - mechanical handling equipment is available, if required, for handling refrigerant cylinders;
 - all personal protective equipment is available and being used correctly;
 - the recovery process is supervised at all times by a competent person;
 - recovery equipment and cylinders conform to the appropriate standards.
- d) Pump down refrigerant system, if possible.
- e) If a vacuum is not possible, make a manifold so that refrigerant can be removed from various parts of the system.
- f) Make sure that cylinder is situated on the scales before recovery takes place.

- g) Start the recovery machine and operate in accordance with manufacturer's instructions.
- h) Do not overfill cylinders. (No more than 80 % volume liquid charge).
- i) Do not exceed the maximum working pressure of the cylinder, even temporarily.
- j) When the cylinders have been filled correctly and the process completed, make sure that the cylinders and the equipment are removed from site promptly and all isolation valves on the equipment are closed off.
- k) Recovered refrigerant shall not be charged into another refrigeration system unless it has been cleaned and checked.

DD.12 Labelling

Equipment shall be labelled stating that it has been de-commissioned and emptied of refrigerant. The label shall be dated and signed. For appliances containing FLAMMABLE REFRIGERANTS, ensure that there are labels on the equipment stating the equipment contains flammable refrigerant.

DD.13 Recover

When removing refrigerant from a system, either for servicing or decommissioning, it is recommended good practice that all refrigerants are removed safely.

When transferring refrigerant into cylinders, ensure that only appropriate refrigerant recovery cylinders are employed. Ensure that the correct number of cylinders for holding the total system charge are available. All cylinders to be used are designated for the recovered refrigerant and labelled for that refrigerant (i.e. special cylinders for the recovery of refrigerant). Cylinders shall be complete with pressure-relief valve and associated shut-off valves in good working order. Empty recovery cylinders are evacuated and, if possible, cooled before recovery occurs.

The recovery equipment shall be in good working order with a set of instructions concerning the equipment that is at hand and shall be suitable for the recovery of all appropriate refrigerants including, when applicable, FLAMMABLE REFRIGERANTS. In addition, a set of calibrated weighing scales shall be available and in good working order. Hoses shall be complete with leak-free disconnect couplings and in good condition. Before using the recovery machine, check that it is in satisfactory working order, has been properly maintained and that any associated electrical components are sealed to prevent ignition in the event of a refrigerant release. Consult manufacturer if in doubt.

The recovered refrigerant shall be returned to the refrigerant supplier in the correct recovery cylinder, and the relevant waste transfer note arranged. Do not mix refrigerants in recovery units and especially not in cylinders.

If compressors or compressor oils are to be removed, ensure that they have been evacuated to an acceptable level to make certain that flammable refrigerant does not remain within the lubricant.

The evacuation process shall be carried out prior to returning the compressor to the suppliers. Only electric heating to the compressor body shall be employed to accelerate this process. When oil is drained from a system, it shall be carried out safely.

“Please note that changes or modifications of this product is not expressly approved by the party responsible for compliance could void the user's authority to operate the equipment.”

NOTE: This equipment has been tested and found to comply with the limits for a Class B digital device, pursuant to Part 15 of the FCC Rules. These limits are designed to provide reasonable protection against harmful interference in a residential installation. This equipment generates, uses and can radiate radio frequency energy and, if not installed and used in accordance with the instructions, may cause harmful interference to radio communications. However, there is no guarantee that interference will not occur in a particular installation.

If this equipment does cause harmful interference to radio or television reception, which can be determined by turning the equipment off and on, the user is encouraged to try to correct the interference by one or more of the following measures:

- Reorient or relocate the receiving antenna.
- Increase the separation between the equipment and receiver.
- Connect the equipment into an outlet on a circuit different from that to which the receiver is connected.
- Consult the dealer or an experienced radio[^]V technician for help.

Competence of service personnel

General

Special training additional to usual refrigerating equipment repair procedures is required when equipment with flammable refrigerants is affected.

In many countries, this training is carried out by national training organisations that are accredited to teach the relevant national competency standards that may be set in legislation.

The achieved competence should be documented by a certificate.

Training

The training should include the substance of the following:

Information about the explosion potential of flammable refrigerants to show that flammables may be dangerous when handled without care.

Information about potential ignition sources, especially those that are not obvious, such as lighters, light switches, vacuum cleaners, electric heaters.

Information about the different safety concepts:

Unventilated - (see Clause GG.2) Safety of the appliance does not depend on ventilation of the housing. Switching off the appliance or opening of the housing has no significant effect on the safety. Nevertheless, it is possible that leaking refrigerant may accumulate inside the enclosure and flammable atmosphere will be released when the enclosure is opened. Ventilated enclosure - (see Clause GG.4) Safety of the appliance depends on ventilation of the housing. Switching off the appliance or opening of the enclosure has a significant effect on the safety. Care should be taken to ensure a sufficient ventilation before.

Ventilated room - (see Clause GG.5) Safety of the appliance depends on the ventilation of the room. Switching off the appliance or opening of the housing has no significant effect on the safety. The ventilation of the room shall not be switched off during repair procedures.

Information about the concept of sealed components and sealed enclosures according to IEC 60079-15:2010.

Information about the correct working procedures:

a) Commissioning

- Ensure that the floor area is sufficient for the refrigerant charge or that the ventilation duct is assembled in a correct manner.
- Connect the pipes and carry out a leak test before charging with refrigerant.
- Check safety equipment before putting into service.

b) Maintenance

- Portable equipment shall be repaired outside or in a workshop specially equipped for servicing units with flammable refrigerants.
- Ensure sufficient ventilation at the repair place.
- Be aware that malfunction of the equipment may be caused by refrigerant loss and a refrigerant leak is possible.
- Discharge capacitors in a way that won't cause any spark. The standard procedure to short circuit the capacitor terminals usually creates sparks.
- Reassemble sealed enclosures accurately. If seals are worn, replace them.
- Check safety equipment before putting into service.

c) Repair

- Portable equipment shall be repaired outside or in a workshop specially equipped for servicing units with flammable refrigerants.
- Ensure sufficient ventilation at the repair place.

- Be aware that malfunction of the equipment may be caused by refrigerant loss and a refrigerant leak is possible.
- Discharge capacitors in a way that won't cause any spark.
- When brazing is required, the following procedures shall be carried out in the right order:
 - Remove the refrigerant. If the recovery is not required by national regulations, drain the refrigerant to the outside. Take care that the drained refrigerant will not cause any danger. In doubt, one person should guard the outlet. Take special care that drained refrigerant will not float back into the building.
 - Evacuate the refrigerant circuit.
 - Purge the refrigerant circuit with nitrogen for 5 min.
 - Evacuate again.
 - Remove parts to be replaced by cutting, not by flame.
 - Purge the braze point with nitrogen during the brazing procedure.
 - Carry out a leak test before charging with refrigerant.
 - Reassemble sealed enclosures accurately. If seals are worn, replace them.
 - Check safety equipment before putting into service.

d) Decommissioning

- If the safety is affected when the equipment is putted out of service, the refrigerant charge shall be removed before decommissioning.
- Ensure sufficient ventilation at the equipment location.
- Be aware that malfunction of the equipment may be caused by refrigerant loss and a refrigerant leak is possible.
- Discharge capacitors in a way that won't cause any spark.
- Remove the refrigerant. If the recovery is not required by national regulations, drain the refrigerant to the outside. Take care that the drained refrigerant will not cause any danger. In doubt, one person should guard the outlet. Take special care that drained refrigerant will not float back into the building.
- Evacuate the refrigerant circuit.
- Purge the refrigerant circuit with nitrogen for 5 min.
- Evacuate again.
- Fill with nitrogen up to atmospheric pressure.
- Put a label on the equipment that the refrigerant is removed.

e) Disposal

- Ensure sufficient ventilation at the working place.
- Remove the refrigerant. If the recovery is not required by national regulations, drain the refrigerant to the outside. Take care that the drained refrigerant will not cause any danger. In doubt, one person should guard the outlet. Take special care that drained refrigerant will not float back into the building.
- Evacuate the refrigerant circuit.
- Purge the refrigerant circuit with nitrogen for 5 min.
- Evacuate again.
- Cut out the compressor and drain the oil.

Every working procedure for maintenance, service and repair operations that affects safety means shall only be carried out by competent persons according to Annex HH (competence of service personnel by training, this training is carried by national training organizations that are accredited to teach the relevant national competency standards that may be set in legislation. The achieved competence should be documented by a certificate).

Examples for such working procedures are:





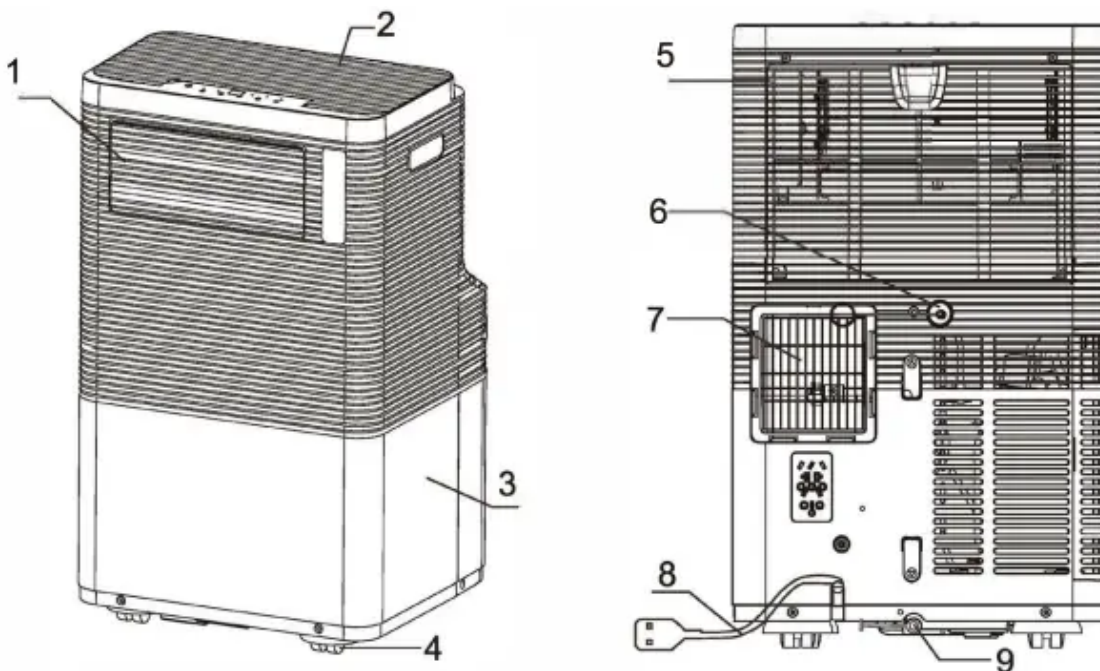

- Breaking into the refrigerating circuit;
- Opening of sealed components;
- Opening of ventilated enclosures;

DESCRIPTION

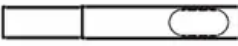

- 1 Louver
- 2 Control panel
- 3 Front panel
- 4 Castor
- 5 Air inlet
- 6 Drainage outlet (When dehumidifying, install the drain pipe first.)
- 7 Air outlet
- 8 power cord
- 9 Drainage outlet (Full water protection or long-term non-use, remove the rubber plug and drain the accumulated water.)

Accessories

Part	Description	Quantity	Part	Description	Quantity
	Exhaust hose	1		Window slider kit	1
	Housing adaptor	1		Dowel	2
	Window Connector	1		Drain Hose	1
	Remote Controller	1		Remote Control Batteries (AAA 1.5V)	2

Note: All the illustrations in this manual are for explanatory purposes only. Your appliance may be slightly different. Be sure all accessories are removed from the packing before use.

Appearance and Function of Control Panel

Top control and display panel (only cooling unit)



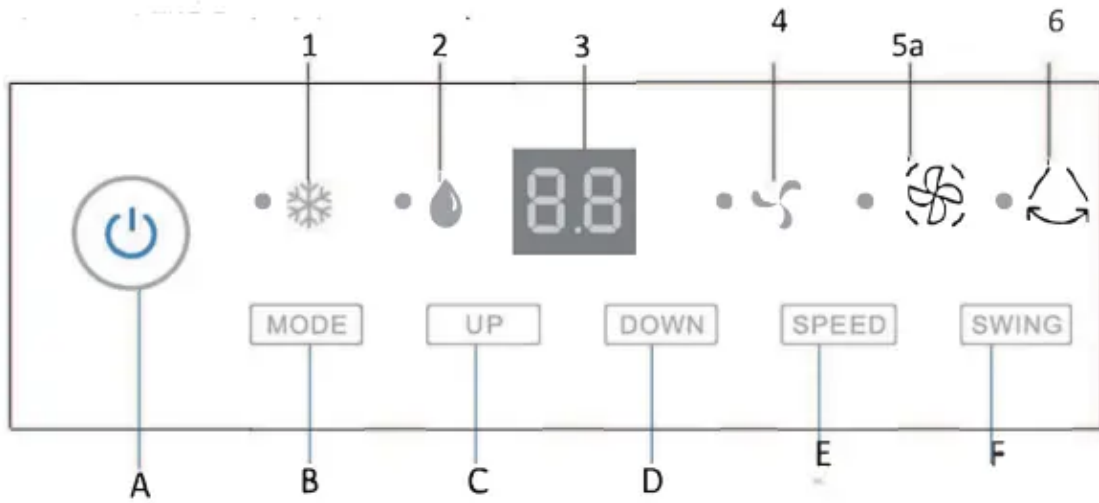

Top control and display panel (cooling and heating unit)

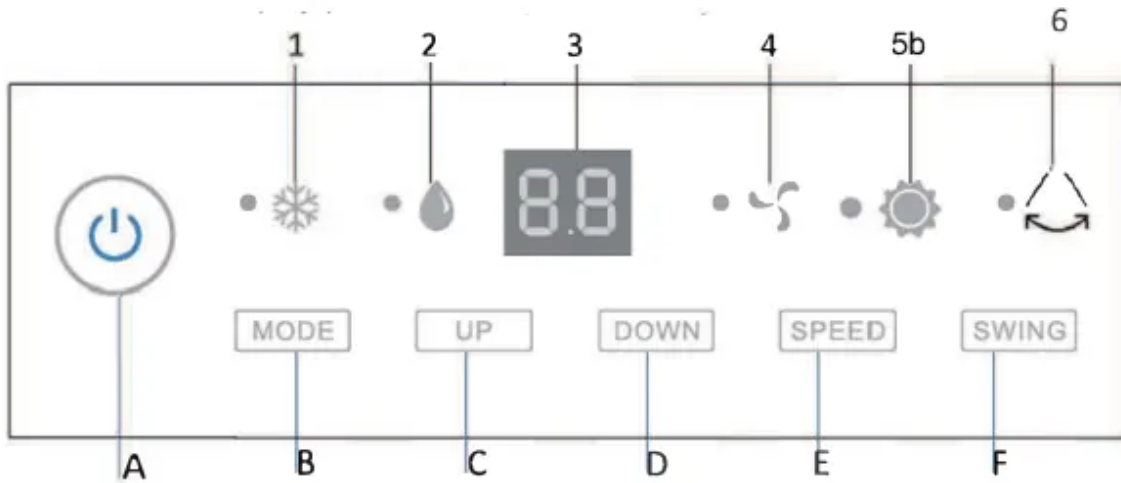

Auxiliary display panel

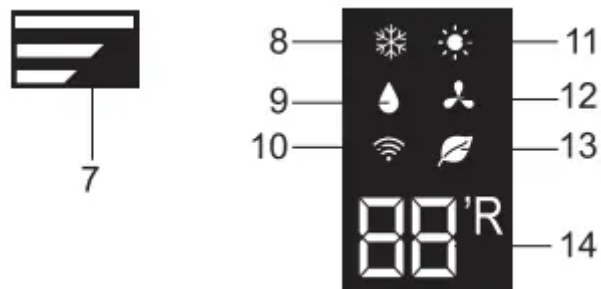

Button		Display	
A	Power on/off	1, 8	Cooling mode
B	Operation mode	2, 9	Dehumidifying
C	Temperature up and time increase	3, 14	Temperature or time display
D	Temperature down and time reduce	4, 12	Fan mode
E	Fan speed	5a	Fan speed
F	Swing on/off	5b	Heating mode
		6	Swing Indicator
		7	fan speed display
		10	Wifi (optional)
		11	Heating display (cooling and heating unit)
		13	UVC (optional)



Appearance and Function of Remote Control

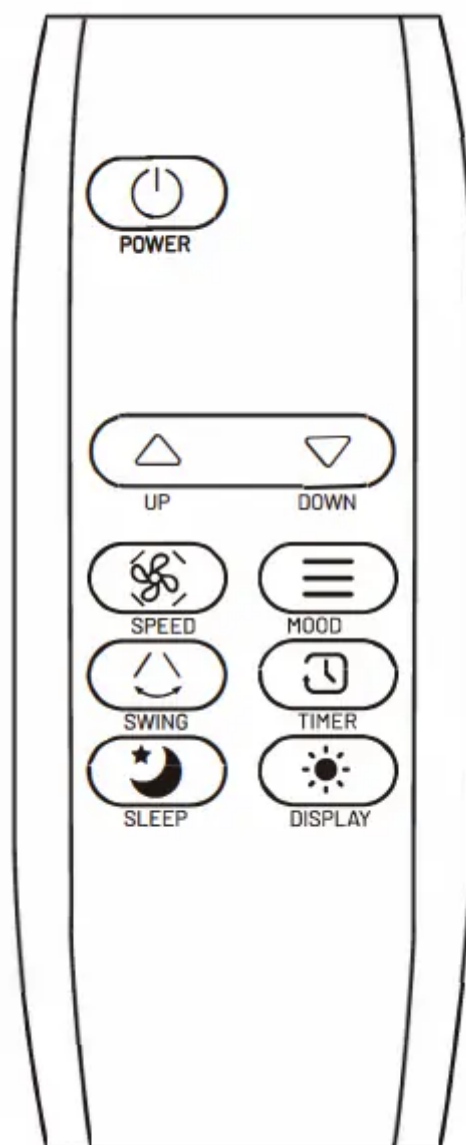

1 POWER	Power on/off
2 UP	Temperature up or Increase timing time
3 DOWN	Temperature down or Reduce timing time
4 SPEED	Fan speed
5 MODE	Operation MODE
6 SWING	Swing on/off
7 TIMER	Timer on/off
8 SLEEP	Sleep mode
9 DISPLAY	Display on/off

Notes:

Do not drop the remote controller.

Do not place the remote controller in a location exposed to direct sunlight Do not mix old and new batteries. Do not mix alkaline, standard (carbon-zinc) or rechargeable (nickel-cadmium) batteries.

Do not dispose of batteries in fire. Batteries may explode or leak.

Operation Introduction

Before starting operations in this section

- 1) Find a place where there is power supply nearby
- 2) As shown in Fig. 5 and Fig 5a, install the exhaust hose, and adjust the window position well

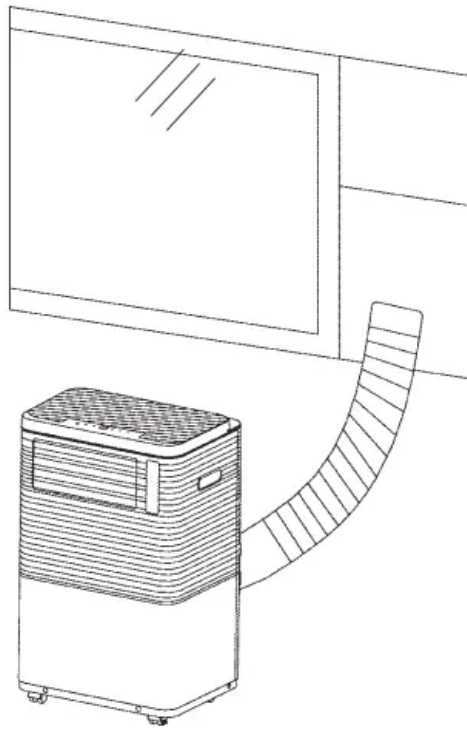

Fig 5

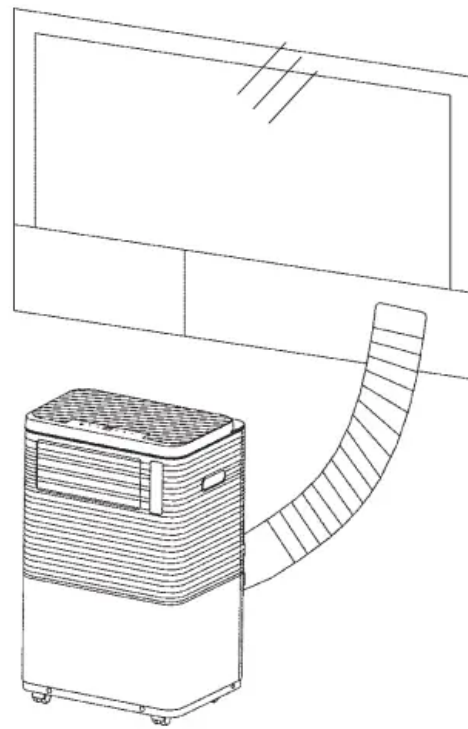

Fig 5a

- 3) As shown in Fig. 6, Connect drain hose well (only for using heating model);
- 4) Insert the power cord into an grounded AC 115V/60Hz socket
- 5) Press the POWER button to turn on the air-conditioner.

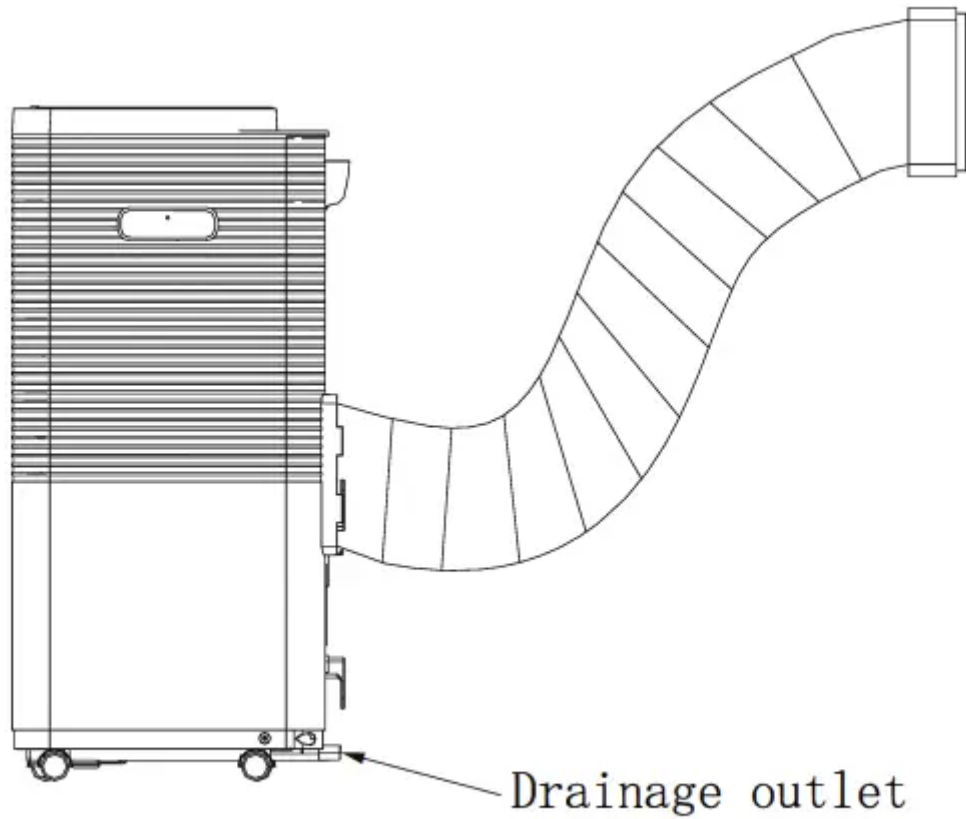

Fig 6

Before using

Notice: By pressing both the "up" and "down" at the same time (>3s), the display will toggle between Celsius and Fahrenheit.

Operation temperature range:

	Maximum cooling	Minimum cooling
DB/WB(°F)	95/75	64/54

	Maximum heating	Minimum heating
DB/WB(°F)	80/--	45/--

- Check up whether the exhaust hose has been mounted properly.
- Power supply meets the requirements
- The socket is for AC use
- Do not share one socket with other appliances
- Power supply is AC 115V/60Hz



Cooling operation

- Press the "MODE" button till the "Cool" icon appears
- Press the "UP" or "DOWN" button to select a desired room temperature (61 °F -90°F)
- Press the "SPEED" button to select fan speed
- Press the "SWING" button to set Air outlet angle

Dehumidifying operation

Press the "MODE" button till the "Dehumidity" icon appears

- Press the "DOWN" or "UP" button to select a desired room temperature (61 °F -90°F)
- Press the "SPEED" button to select fan speed
- Press the "SWING" button to set Air outlet angle

Fan operation

- Press the "MODE" button till the "Fan" icon appears.
- Press the "SPEED" button to select fan speed
- Press the "SWING" button to set Air outlet angle

Heating operation (this function is not available for a cold-single unit)

- Press the "MODE" button till the "Heat" icon appears
- Press the "DOWN" or "UP" button to select a desired room temperature (61 °F -90°F)
- Press the "SPEED" button to select wind speed
- Press the "SWING" button to set Air outlet angle

(Entering the heating mode, it takes a few minutes for the internal temperature to rise before the wind starts.)

Display operation

After machine turns on, press this key, all led are closed, press this button again, all led are restored

Timer operation

User can set the timing with the remote control.

1) Timer ON setting:

- When the air-conditioner is OFF, press the "TIMER" button of remote control, and select a desired ON time through the "UP" and "DOWN" buttons.

- "Preset ON Time" is displayed on the operation panel
- ON time can be regulated in 1-24 hours

2) Timer OFF setting:

- When the air-conditioner ON, press "Timer" button of remote control, and select a desired OFF time through the "UP" and "DOWN" buttons.
- "Preset OFF Time" is displayed on the operation panel
- OFF time can be regulated in 1-24 hours

SWING

After machine turns on, press this key, the louver will swing continuously up and down; by pressing this button again the movement will stop and the louver remain in that position

SLEEP mode

- While in cooling mode, press the SLEEP key to set the temperature. It increases 1 °F after an hour and at most increases 2°F after 2 hours
- While in heating mode, press the "SLEEP" key to set the temperature. It decreases 1°F after an hour and at most decreases 2 °F after 2 hours
- Press the SLEEP key again can cancel the setting
- High speed cannot be set in sleep mode
- Enter sleep mode, except for the sleep light, all displays are on for 5 seconds and then go out

Installation Explanations

Installation Explanations:

- A removal air-conditioner shall be installed in the flat and empty place all around. Don't block the air outlet, and the required distance around should be at least 30cm. (See Fig 8)
- Should not be installed in wet location, such as the laundry room
- Socket wiring should be in accordance with the local electric safety requirements >30cm

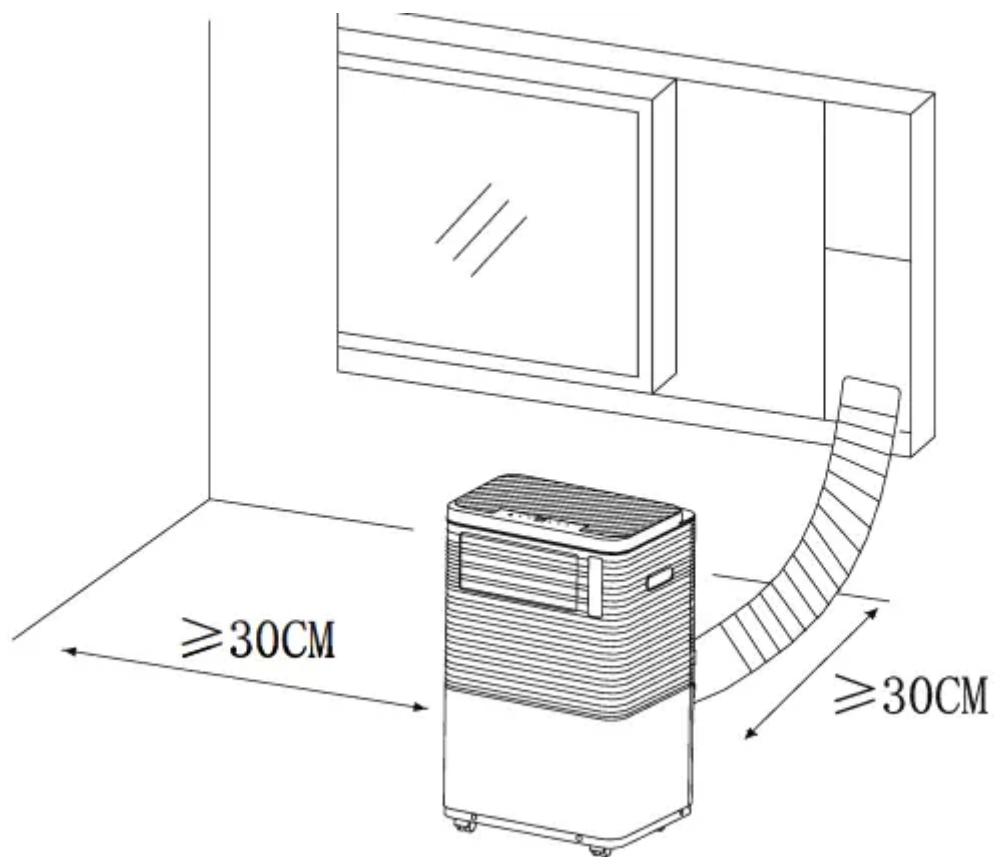

Introduction to Exhaust Hose Installation Temporary installation

1. Twist the housing adaptor and the window Connector to the ends of the exhaust hose
2. Insert the fixing clip of the housing adaptor into the openings at back of the air-conditioner
3. Put the other end of the exhaust hose to the near window sill(see Fig 9)

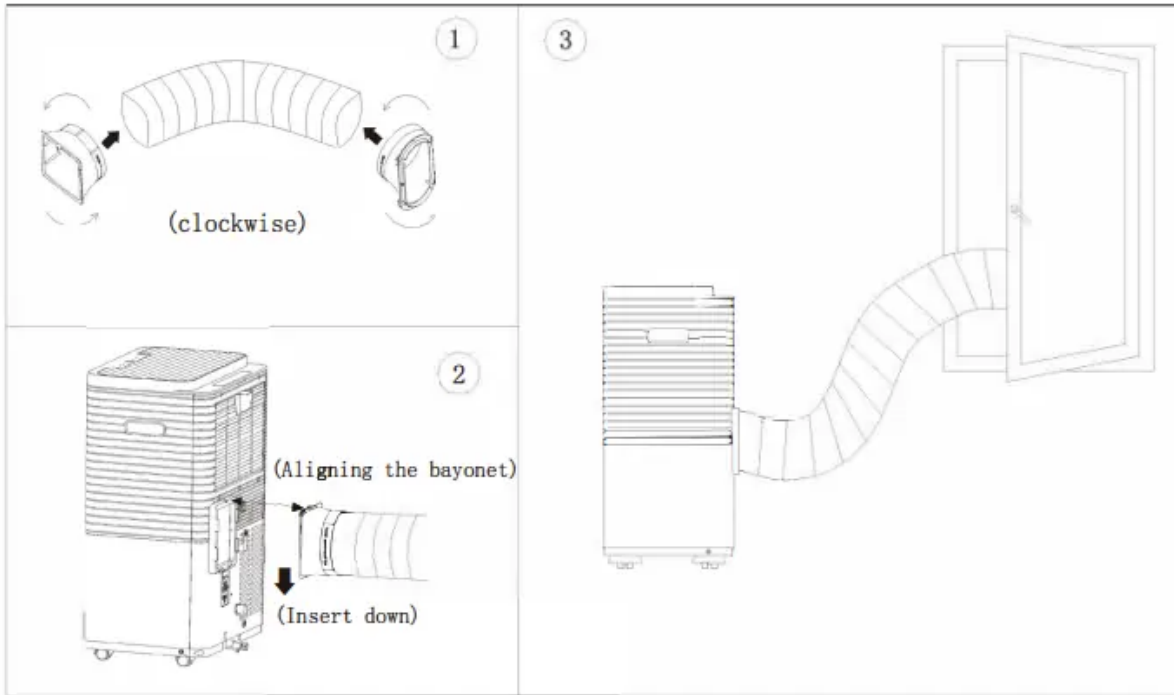
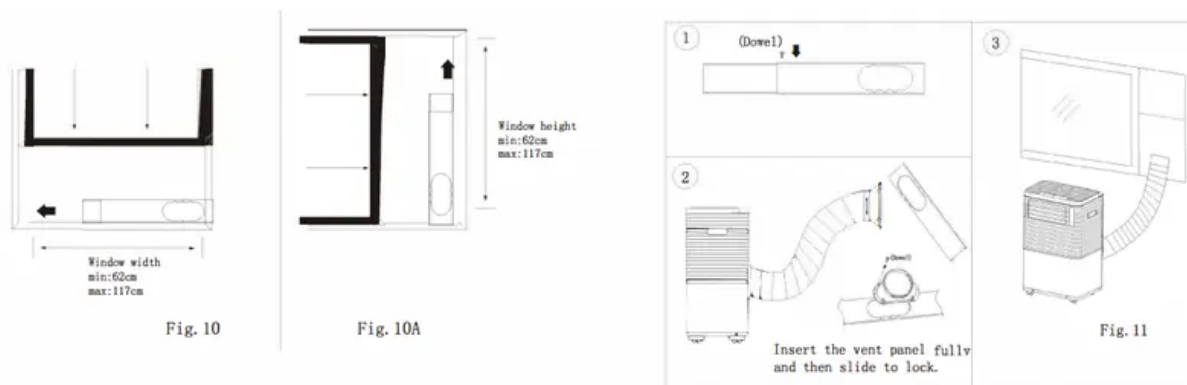

Fig. 9

Window Kit installation

The installation manner of window slider kit is mostly in "horizontal" or "vertical" .As shown Fig 10 and Fig 10a, check the min. and max. size of the window before the installation.

1. Install the window kit on the window(Fig. 10, Fig 10a);
2. Adjust the length of the window slider kit according to the window width or height, and fix it with the dowel
3. Insert the window connector of the hose to the hole of the window kit(Fig. 11)



Water Full alarm

The inner water fray inside the air-conditioner has one water level safety switches, it controls water level. When water level reaches an anticipated height, the display panel will give an alarm P7 or F7

. (If water pump is damaged, when the water is full, please remove the rubber blockage at the bottom of unit and all water will be drained outside

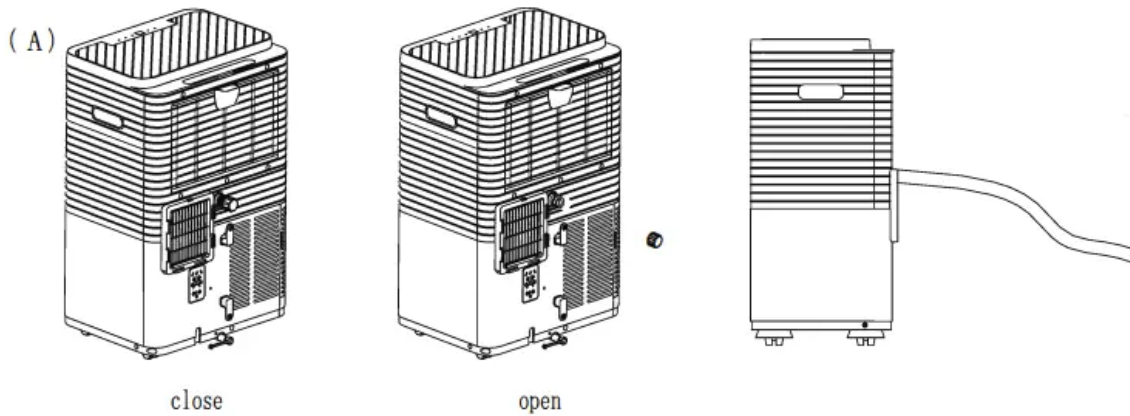

1. In high-humidity environment cooling or dehumidification mode, follow the position of Figure A to keep the drain pipe connected

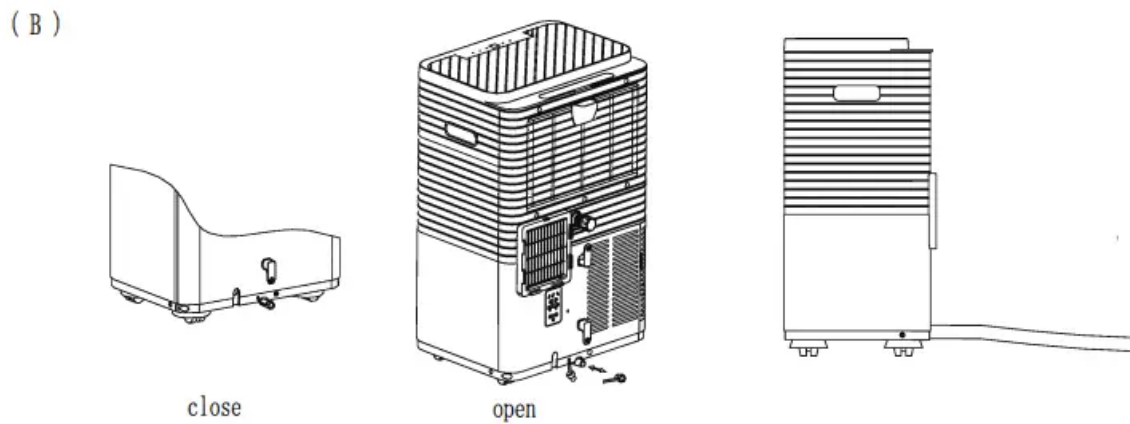

2. When the water is full of protection alarm or when it is not used for a long time, connect the drain pipe according to the position of Figure B to remove the accumulated water.

Maintenance Explanations

Declaration

- 1) Before cleaning, be sure to disconnect the unit from any electric supply outlet;
- 2) Do not use gasoline or other chemicals to clean the unit
- 3) Do not wash the unit directly
- 4) If the conditioner is damaged, please contact the dealer or repair shop

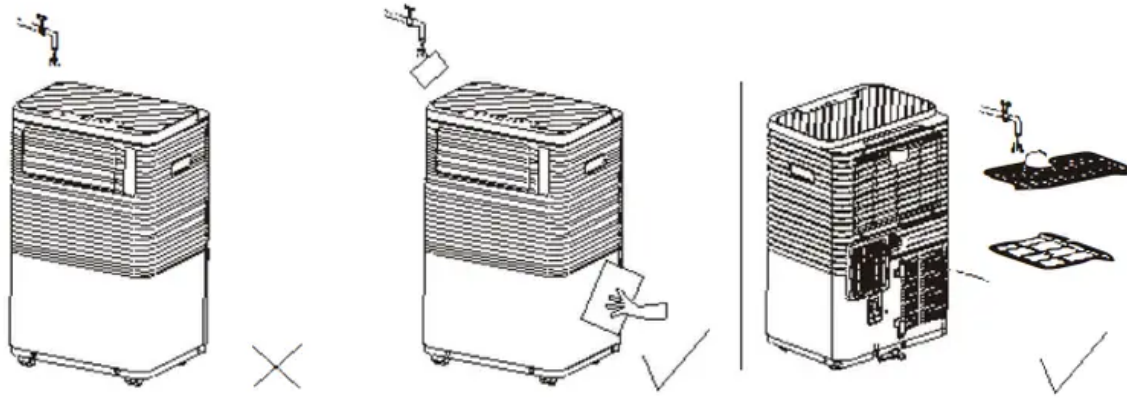

Air Filter

- If the air filter becomes clogged with dust/dirt, the air filter should be cleaned once every two weeks.

- Dismounting

Open the air inlet grille and take off air filter.

- Cleaning

Clean the air filter with neutral detergent in lukewarm (104°F) and dry it up in the shade

- Mounting

Putting the air filter into the inlet grille, replace the components as they were

Clean the Air-conditioner Surface

First clean the surface with a neutral detergent and wet cloth, and then wipe it with a dry cloth

Troubleshooting

Troubles	Possible Causes	Suggested Remedies
1. Unit does not start when pressing on/off button	Water full fault alarm and water tank is full	Dump the water out of the water tank
	Room temperature is higher than the setting temperature(Electric heating mode)	Reset the temperature
	Room temperature is lower than the setting temperature (Cooling mode)	Reset the temperature
2. Not cool enough	The doors or windows are not closed	Make sure all the windows and doors are close
	There are heat sources inside the room	Remove the heat sources if possible
	Exhaust air hose is not connected or blocked	Connect or clean the exhaust air hose
	Temperature setting is too high.	Reset the temperature
	Air inlet is blocked	Clean the air inlet
3.Noisy	The ground is not level or not flat enough	Place the unit on a flat, level ground if possible
	The sound comes from the flowing of the refrigerant inside the air conditioner	It is normal
4. F1 Code	Room temperature sensor failed	Replace room temperature sensor(the unit can also work without replacement)

5. F2 Code	Evaporator temperature sensor failed	Replace evaporator temperature sensor(the unit can also work without replacement)
6. P7 OR F7 Code	Water tank full	Please empty the water tank
7. F8 Code	Water level switch failed	Check if the water level switch loose or dropped, or replace a new one.

Wiring Diagram

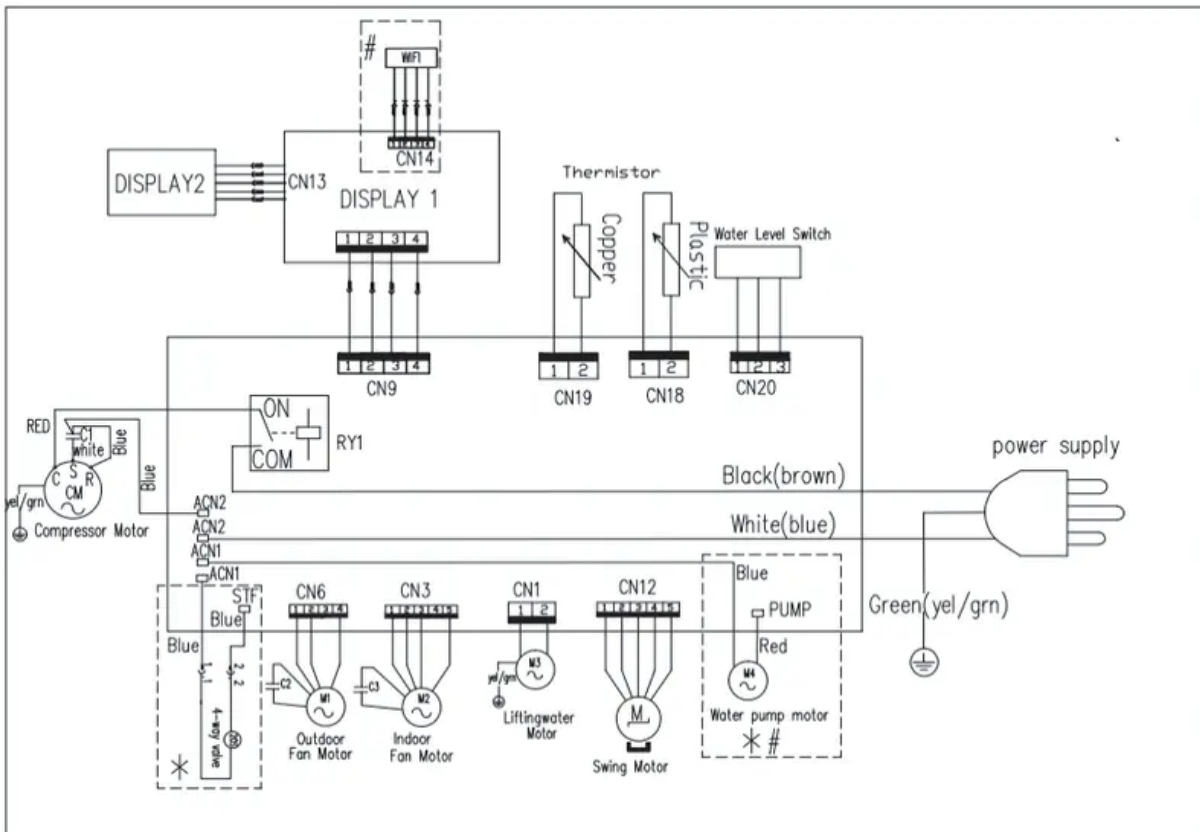

NOTE: The part marked # will be cancelled for the unit which is no Optional function.(please comply with actual appliance you selected) The part marked will be cancelled for the unit which is only cooling model.

Warning



This content is compiled from multiple sources and is provided for reference purposes only. It may not be complete or fully applicable to all situations. If you are unable to resolve your issue, please contact the product manufacturer or an authorized service provider for official support.

Document generated by [ManualsFile](#)

