

User Manual for Airfryer

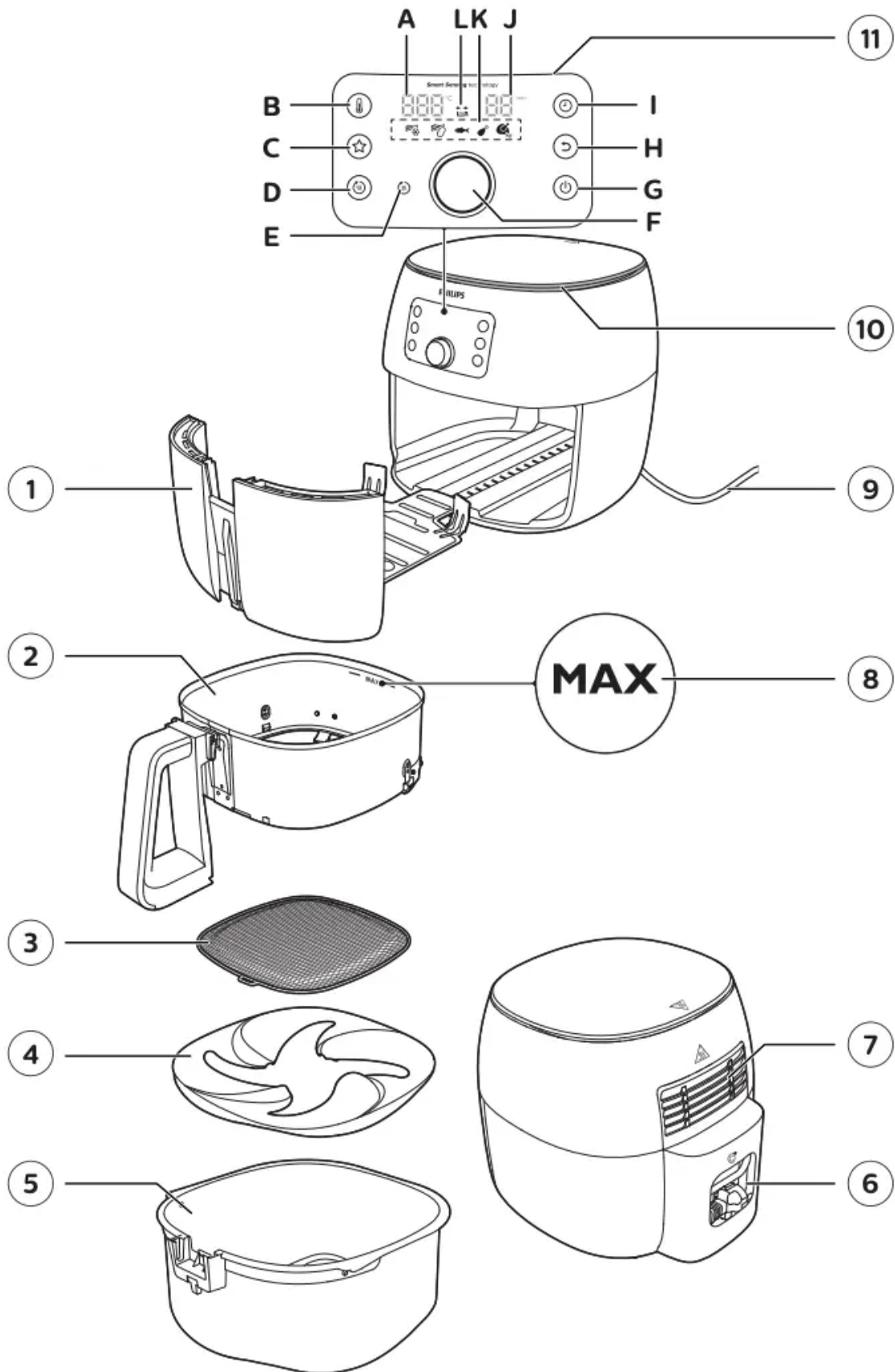

General description



1 Drawer

- 2 Basket with removable mesh bottom
- 3 Removable mesh bottom
- 4 Fat reducer
- 5 Pan
- 6 Cord storage compartment
- 7 Air outlets
- 8 MAX indication
- 9 Power cord
- 10 Air inlet
- 11 Control panel
- A Temperature indication
- B Temperature button
- C Favorites button
- D Keep warm button
- E Keep warm indication
- F QuickControl dial
- G Power On/Off button
- H Return button
- I Timer button
- J Time indication
- K Smart Chef programs: Frozen fries/home-made fries/ whole fish/ chicken drumsticks/whole chicken
- L Shake indication

Before first use

1. Remove all packing material.
2. Remove any stickers or labels (if available) from the appliance.
3. Thoroughly clean the appliance before first use, as indicated in the cleaning chapter.

Preparing for use

Placing the removable mesh bottom and fat reducer

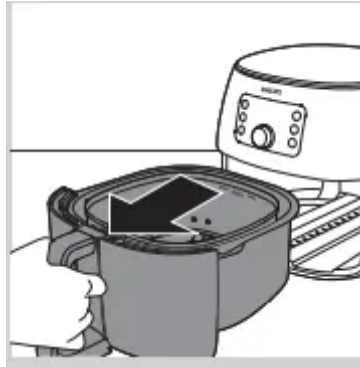

1. Open the drawer by pulling the handle.

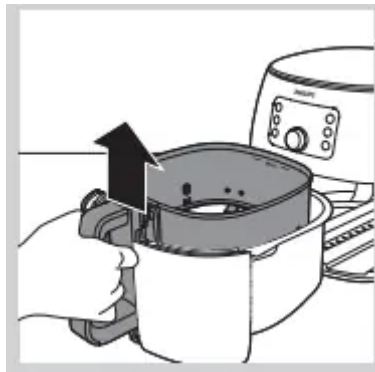

2. Remove the basket by lifting the handle.

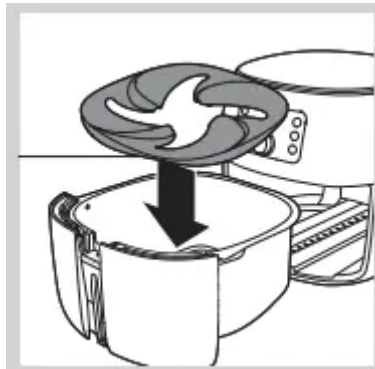

3. Place the fat reducer into the pan.

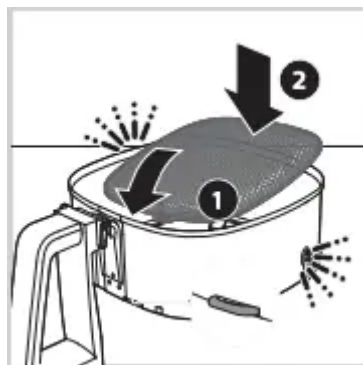

4. Insert the removable mesh bottom into the slot on the right bottom side of the basket. Push the mesh bottom down until it locks into position (“click” on both sides).



5. Put the basket in the pan.



6. Slide the drawer back into the Airfryer by the handle.

Note

- Never use the pan without the fat reducer or the basket in it.

Food table for manual time/temperature settings

The table below helps you select the basic settings for the types of food you want to prepare.

Note

- Keep in mind that these settings are suggestions. As ingredients differ in origin, size, shape as well as brand, we cannot guarantee the best setting for your ingredients.
- When preparing larger amount of food (e.g. fries, prawns, drumsticks, frozen snacks), shake, turn, or stir the ingredients in the basket 2 to 3 times in order to achieve a consistent result.



Ingredients	Min.– max. amount	Time (min)	Temperature	Note
Home-made fries (12 x 12 mm/0.5 x 0.5 in)	200–1400 g 7–49 oz	18–35	180°C/350°F	<ul style="list-style-type: none"> • Soak 30 minutes in cold water or 3 minutes in luke warm water (40°C/104°F), dry then add 1 tbsp of oil per 500 g/18 oz. • Shake, turn, or stir halfway
Homemade potato wedges	200–1400 g 7–49 oz	20–42	180°C/350°F	<ul style="list-style-type: none"> • Soak 30 minutes in water, dry then add 1/4 to 1 tbsp of oil. • Shake, turn, or stir halfway
Frozen snacks (chicken nuggets)	80–1300 g/ 3–46 oz (6–50 pieces)	7–18	180°C/350°F	<ul style="list-style-type: none"> • Ready when golden yellow and crispy outside. • Shake, turn, or stir halfway
Frozen snacks (small spring rolls around 20 g/0.7 oz)	100–600 g/ 4–21 oz (5–30 pieces)	14–16	180°C/350°F	<ul style="list-style-type: none"> • Ready when golden yellow and crispy outside. • Shake, turn, or stir halfway

Ingredients	Min.– max. amount	Time (min)	Temperature	Note
Chicken breast Around 160 g/6 oz	1–5 pieces	18–22	180°C/350°F	
Chicken fingers bread crumbed	3–12 pieces (1 layer)	10–15	180°C/350°F	• Add oil to the breadcrumbs. Ready when golden yellow.
Chicken wings Around 100 g/3.5 oz	2–8 pieces (1 layer)	14–18	180°C/350°F	• Shake, turn, or stir halfway
Meat chops without bone Around 150 g/6 oz	1–5 chops	10–13	200°C/400°F	
Hamburger Around 150 g/6 oz (diameter 10 cm/4 in)	1–4 patties	10–15	200°C/400°F	
Thick sausages Around 100 g/3.5 oz (diameter 4 cm/1.6 in)	1–6 pieces (1 layer)	12–15	200°C/400°F	
Thin sausages Around 70 g/2.5 oz (diameter 2 cm/0.8 in)	1–7 pieces	9–12	200°C/400°F	
Pork roast	500–1000 g/ 18–35 oz	40–60	180°C/350°F	• Let it rest for 5 minutes before cutting.
Fish filets Around 120 g/4.2 oz	1–3 (1 layer)	9–20	160°C/325°F	• In order to avoid sticking, place the skin side to the bottom and add some oil.
Shellfish Around 25–30 g/0.9–1 oz	200–1500 g/ 7–53 oz	10–25	200°C/400°F	• Shake, turn, or stir halfway
Cake	500 g/18 oz	28	180°C/350°F	• Use a cake pan.
Muffins Around 50 g/1.8 oz	1–9	12–14	180°C/350°F	• Use heat-proof silicone muffin cups.
Quiche (diameter 21 cm/8.3 in)	1	15	180°C/350°F	• Use a baking tray or oven dish.
Pre-baked toast / bread rolls	1–6	6–7	180°C/350°F	
Fresh bread	700 g/25 oz	38	160°C/325°F	• The shape should be as flat as possible to avoid that the bread touches the heating element when rising.
Fresh rolls Around 80 g/2.8 oz	1–6 pieces	18–20	160°C/325°F	
Chestnuts	200–2000 g/ 7–70 oz	15–30	200°C/400°F	• Shake, turn, or stir halfway
Mixed vegetable (roughly chopped)	300–800 g/ 11–28 oz	10–20	200°C/400°F	• Set the cooking time according to your own taste. • Shake, turn, or stir halfway

Using the appliance

Airfrying

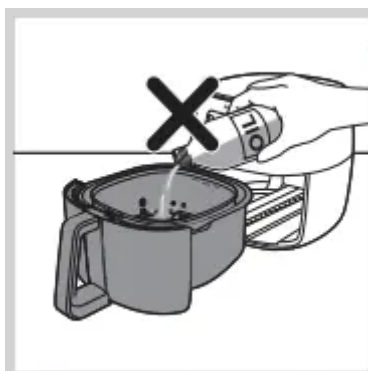

Caution

- This is an Airfryer that works on hot air. Do not fill the pan with oil, frying fat or any other liquid.
 - Do not touch hot surfaces. Use handles or knobs. Handle the hot pan and fat reducer with oven-safe gloves.
 - This appliance is for household use only.
 - This appliance may produce some smoke when you use it for the first time. This is normal.
 - Preheating of the appliance is not necessary.
1. Place the appliance on a stable, horizontal, level and heat-resistant surface. Make sure the drawer can be opened completely.

Note

- Do not put anything on top or on the sides of the appliance. This could disrupt the airflow and affect the frying result.

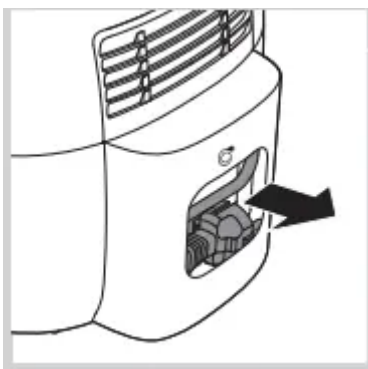

2. Pull the power cord out of the cord storage compartment at the back of the appliance.

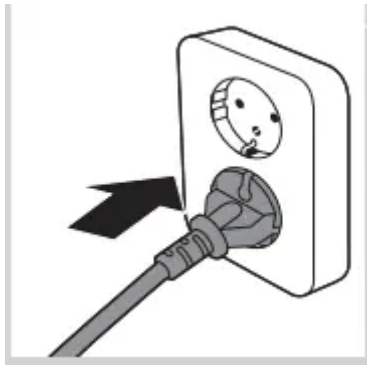

3. Put the plug in the wall outlet.

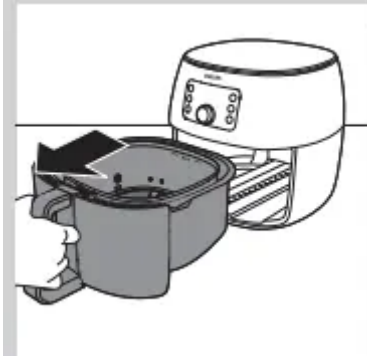

4. Open the drawer by pulling the handle.



5. Put the ingredients in the basket.

Note

- The Airfryer can prepare a large range of ingredients. Consult the 'Food table' for the right quantities and approximate cooking times.
- Do not exceed the amount indicated in the 'Food table' section or overfill the basket beyond the 'MAX' indication as this could affect the quality of the end result.
- If you want to prepare different ingredients at the same time, make sure you check the suggested cooking time required for the different ingredients before you start to cook them simultaneously.

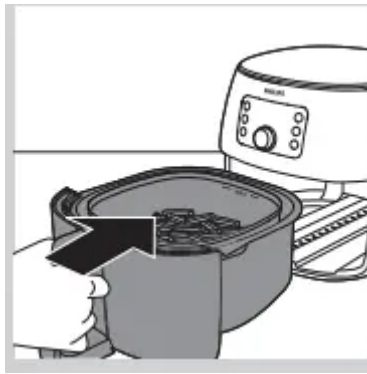

6. Slide the drawer back into the Airfryer by the handle.

Caution

- Never use the pan without the fat reducer or basket in it. If you heat up the appliance without basket, use oven gloves to open the drawer. The edges and inside of the drawer become very hot.
- Do not touch the pan, fat reducer or basket during and for some time after use, as they get very hot.



7. Press the power On/Off button  to switch on the appliance.

Note

- To start with the Smart Chef programs, refer to chapter “Cooking with Smart Chef programs”.

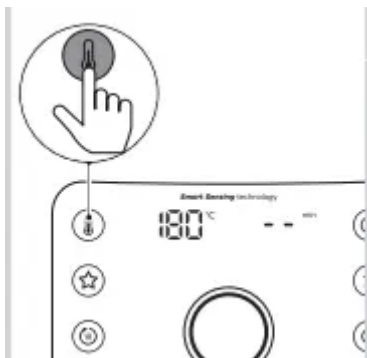

8. Press the temperature button  .

↳ The temperature indication blinks on the screen.

Note

- If you press the timer button  first, the appliance will start cooking right after the cooking time has been confirmed.



9. Turn the QuickControl dial to choose your desired cooking temperature.



10. Push the QuickControl dial to confirm the selected temperature.

↳ After the temperature is confirmed, the time indication starts blinking on the screen.



11. Turn the QuickControl dial to choose your desired cooking time.

Note

- If you press the favorite button  you will save this cooking temperature and time as your favorite cooking settings. Any previously saved settings will be overwritten. For more details, refer to chapter "Save your favorite setting".

- Refer to the food table for manual time/temperature settings for different types of food.

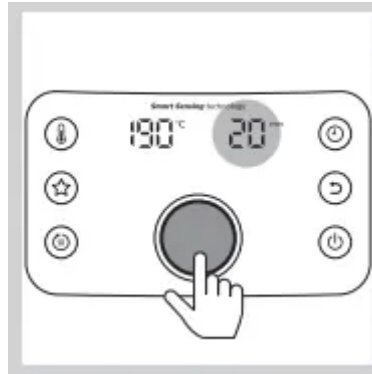

12. Push the QuickControl dial to confirm the selected time.

13. The appliance starts cooking after the cooking time has been confirmed.

Tip

- To pause the cooking process, push the QuickControl dial. To resume the cooking process, push the QuickControl dial again.
- To change the cooking temperature or time during cooking, repeat steps 8–10.
- To cancel any ongoing process and go back to the main menu, press the return button .



Note

- If you do not set the required cooking time within 30 minutes, the appliance automatically shuts off for safety reasons.
- If “- -” is selected as the time indication, the appliance goes into preheating mode.
- Some ingredients require shaking or turning halfway through the cooking time see (‘Food table’). To shake the ingredients, press the QuickControl dial to pause cooking, open the drawer and lift the basket out of the pan and shake it over the sink. Then slide the pan with the basket back into the appliance, and press the QuickControl dial to resume cooking.
- If you set the timer to half the cooking time, when you hear the timer bell it is time to shake or turn the ingredients. Be sure to reset the timer to the remaining cooking time.

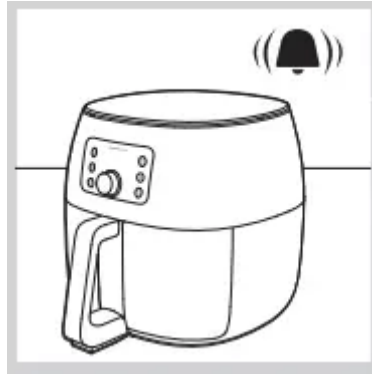

14. When you hear the timer bell, the cooking time has elapsed.



15. Open the drawer by pulling the handle and check if the ingredients are ready.

Note

- If the ingredients are not ready yet, simply slide the drawer back into the Airfryer by the handle and add a few extra minutes to the set time.



16. To remove small ingredients (e.g. fries), lift the basket out of the pan by the handle.

Caution

- After the cooking process, the pan, the fat reducer, the basket, interior housing and the ingredients are hot. Depending on the type of ingredients in the Airfryer, steam may escape from the pan.

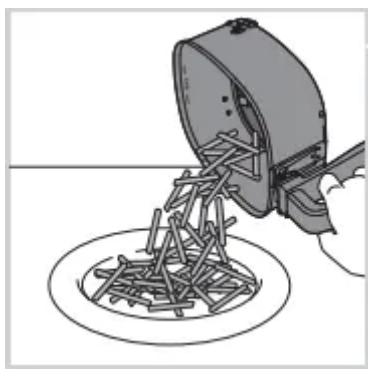

17. Empty the basket contents into a bowl or onto a plate. Always remove the basket from the pan to empty contents as hot oil may be in bottom of the pan.

Note

- To remove large or fragile ingredients, use a pair of tongs to lift out ingredients.
- Excess oil or rendered fat from the ingredients is collected on the bottom of the pan below the fat reducer.
- Depending on the type of ingredients cooking, you may want to carefully pour off any excess oil or rendered fat from the pan after each batch or before shaking or replacing the basket in the pan. Place the basket on a heat-resistant surface. Wearing oven-safe gloves, lift the pan off tracks and place on heatresistant surface. Carefully remove the fat reducer from the pan using rubber tipped tongs. Pour off excess oil or rendered fat. Return the fat reducer to the pan, the pan to the drawer and the basket to the pan.

When a batch of ingredients is ready, the Airfryer is instantly ready for preparing another batch.







Note

- Repeat steps 4 to 17 if you want to prepare another batch.

Food table for Smart Chef programs

Note

- This appliance is for indoor use only. Start the automatic cooking programs with the appliance at room temperature—do not pre-heat.
- Always distribute the food evenly in the basket.
- Turn/shake the food if indicated by the appliance. Keep the drawer open as short as possible.
- Do not use any accessories. Make sure that the fat reducer is properly placed in the appliance.
- As food differs in origin, size and brand, make sure it is sufficiently cooked before serving.

Smart Chef programs for			Directions
 Frozen fries	Thin (7x7mm) Medium (10x10mm) Frozen potato based snacks	200–1400g	<ul style="list-style-type: none"> • Use frozen fries directly from freezer. Do not thaw before cooking. • The program is developed for thin (7x7mm) and medium (10x10mm) frozen fries. • If you purchased fries specially made for Airfryer, please follow instructions on the package
 Home-made fries	Home made cut (10x10mm)	500–1400g	<ul style="list-style-type: none"> • Use floury, raw potatoes. Do not pre-cook potatoes. • Do not use potatoes stored below 6°C. • Follow the fresh fries recipe for best results.
 Fish	A whole fish Big flat fish Fish fillet	1-4 pcs (300-1600g) 1 pcs (up to 800g) 2-5 pcs (150-200g/pcs), up to 700g	<ul style="list-style-type: none"> • Do not cook frozen fish • The program is developed for whole fish around 300–400 g. • If smoke occurs, please use manual mode with lower temperatures.
 Drumsticks	Drumsticks Chicken breast	2-16 pcs (200-2000g) 1-5 pcs (up to 150g /pcs)	<ul style="list-style-type: none"> • The program is developed for fresh (nonfrozen) drumsticks. If you want to cook whole chicken legs, add manually 5-10 minutes cooking time after the Smart Chef program has stopped.
 A whole chicken	A whole chicken Half chicken	1000-1800g >1000g	<ul style="list-style-type: none"> • Only cook raw chicken in the Airfryer. Do not cook frozen chicken. • The program is developed for a whole chicken.

Cooking with Smart Chef programs

Season your ingredients as desired. Put the food inside the basket and slide the basket inside the appliance.

Note

- Do not use honey, syrups or any other sugary ingredients to season your food, since the browning will get very dark.

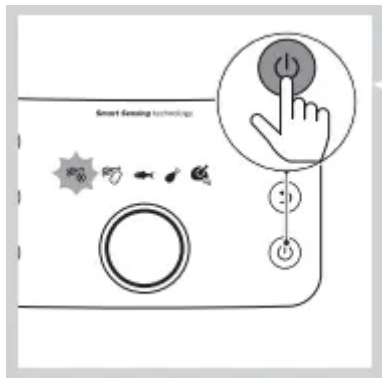

1 Press the On/Off button  to switch on the appliance.



2 To change the Smart Chef program, turn the QuickControl dial until the desired icon is blinking.

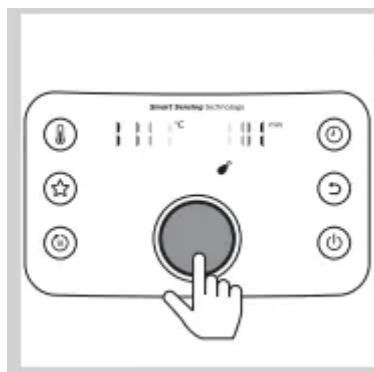

3 To confirm the Smart Chef program, press the QuickControl dial.

↳ The appliance automatically calculates the ideal cooking temperature and time. The screen displays the first estimated cooking temperature and time after a few minutes. During this time the

appliance has already started cooking. As long as the screen displays the blinking bars and the temperature/time alternately, the appliance is still calculating the cooking time, and the appliance will automatically adjust the time during cooking.

Note

- To prepare a whole chicken, weigh the chicken before placing it in the basket. Choose the weight by turning the QuickControl dial and pressing it to confirm.
- Do not pull out the drawer as long as the appliance is calculating the cooking time, which is indicated by blinking bars on the display. Otherwise the Smart Chef program will stop, and the appliance will reset to the main menu. Proceed cooking with the manual mode because restarting the Smart Chef program with partially cooked food will lead to a wrong estimation of the cooking time.
- As soon as the calculation phase is finished you will see the temperature and time displayed continuously (without blinking bars), and you may open the drawer to check the status of the food.



4 When you hear the bell and see the shake indication blinking, open the drawer and turn the ingredients or shake the basket with the ingredients. Then slide the basket back into the appliance.

5 When you hear the bell and the timer has elapsed to 0, the food is ready.

Note

- If your food is underdone or the food does not reach your preferred browning level, proceed cooking for several more minutes by pressing the timer button (see steps 11–12 in chapter “Using the appliance”).

Making home-made fries

To make great home-made fries in the Airfryer:



1. Peel the potatoes and cut into sticks (10 x 10 mm/0.4 x 0.4 in thick).
2. Soak the potato sticks in a bowl of lukewarm water (~40°C/100°F) for minutes.
3. Empty the bowl and dry the potato sticks with a dish towel or paper towel.

4. Pour 1–3 tablespoons of cooking oil in the bowl, put the sticks in the bowl and mix until the sticks are coated with oil.
5. Remove the sticks from the bowl with your fingers or a slotted kitchen utensil so excess oil remains in the bowl.

Note

- Do not tilt the bowl to pour all the sticks in the basket at once to prevent excess oil from going into the pan.

6. Put the sticks in the basket.

7. Start the Smart Chef program for home-made fries . When shaking of the fries is needed, you will hear the timer bell and see the blinking shaking icon  on the display.

Note

- Consult the chapter “Food table for Smart Chef programs” for the right quantities.

Choosing the keep warm mode

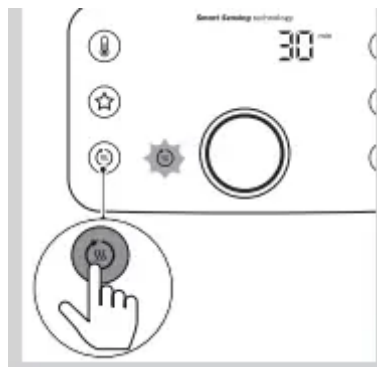

1 Press the keep warm button  (you can activate the keep warm mode at any time).

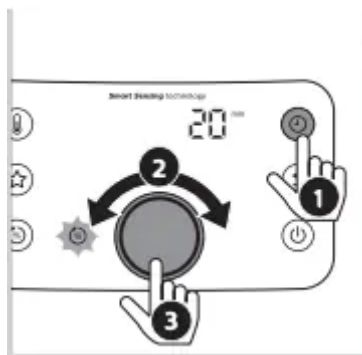

↳ The keep warm indication lights up with pulsing effect.



↳ The keep warm timer is set to 30 minutes. To change the keep warm time (1–30 min), press the timer button , turn the QuickControl dial and then push it to confirm. You cannot adjust the keep warm temperature.



2 To pause the keep warm mode, push the QuickControl dial. To resume the keep warm mode, push the QuickControl dial again.

3 To exit the keep warm mode, press the return button  or the On/Off button .

Tip

- If food like French fries loses too much crispness during the keep warm mode, either shorten the keep warm time by switching off the appliance earlier or crisp them up for 2–3 minutes at the temperature of 180°C.

Note

- If you activate the keep warm mode during cooking (the keep warm indication lights up), the appliance will keep your food warm for 30 minutes after the cooking time has elapsed.
- During the keep warm mode, the fan and heater inside of the appliance turn on from time to time.
- The keep warm mode is designed to keep your dish warm immediately after it is cooked in the Airfryer. It is not meant for reheating.

Save your favorite setting

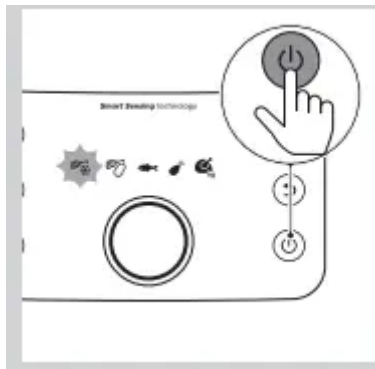

1 Press the On/Off button  to switch on the appliance.

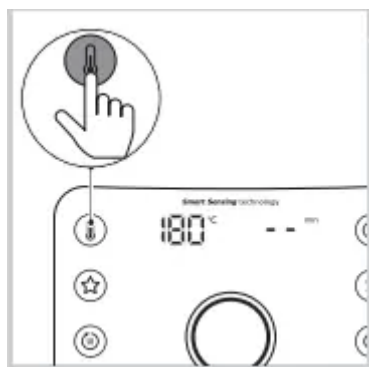

2 Press the temperature button .



3 Turn the QuickControl dial to select the temperature.



4 Press the QuickControl dial to confirm the chosen temperature.



5 Turn the QuickControl dial to select the time.

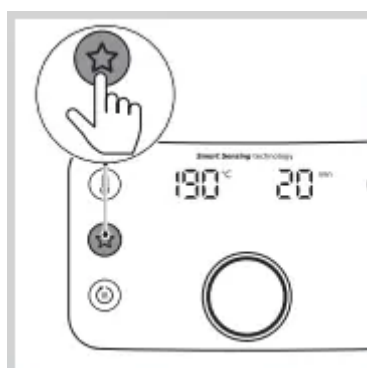

6 Press the favorite button  to save your setting. You will hear a beep after the setting is saved.



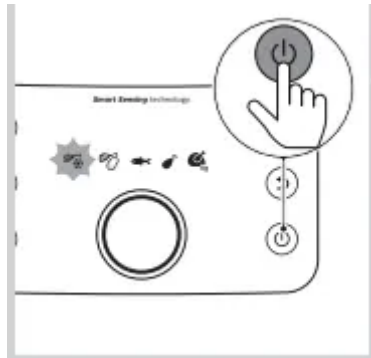

7 Press the QuickControl dial to start the cooking process.

Cooking with a favorite setting

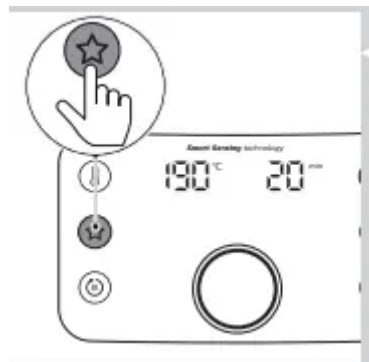

1 Press the On/Off button  to switch on the appliance.



2 Press the favorite button  .



3 Press the QuickControl dial to start the cooking process.

Note

- You can overwrite your favorite setting by applying the same procedure as mentioned above.
- Pressing the favorite button in the manual mode will overwrite your favorite setting. To apply your favorite setting, press the return button to exit the manual mode first.
- To exit the favorite mode, press the return button .
- During cooking with the favorite mode, you will be able to change the temperature or time by pressing the temperature or timer button. The change will not overwrite the stored favorite setting.

Cleaning

Warning

- Let the basket, pan, fat reducer and the inside of the appliance cool down completely before you start cleaning.
- Remove the fat reducer from the pan using rubber tipped tongs. Do not remove using your fingers as hot fat or oil collects under the fat reducer.
- The pan, basket, fat reducer and inside of the appliance have a non-stick coating. Do not use metal kitchen utensils or abrasive cleaning materials as this may damage the non-stick coating.

Clean the appliance after every use. Remove oil and fat from the bottom of the pan after every use.

1 Press the power On/Off button  to switch off the appliance, remove the plug from the wall outlet and let the appliance cool down.

Tip

- Remove the pan and basket to let the Airfryer cool down more quickly.
- 2 Remove the fat reducer from the pan using rubber tipped tongs. Dispose of rendered fat or oil from the bottom of the pan.
- 3 Clean the pan, basket and fat reducer in a dishwasher. You can also clean them with hot water, dishwashing liquid and a non-abrasive sponge (see 'cleaning table').

Tip

- If food residues stuck to the pan, fat reducer or basket, you can soak them in hot water and dishwashing liquid for 10–15 minutes. Soaking loosens the food residues and makes it easier to remove. Make sure you use a dishwashing liquid that can dissolve oil and

grease. If there are grease stains on the pan, fat reducer or basket and you have not been able to remove them with hot water and dishwashing liquid, use a liquid degreaser.

- If necessary, food residues stuck to the heating element can be removed with a soft to medium bristle brush. Do not use a steel wire brush or a hard bristle brush, as this might damage the coating on the heating element.

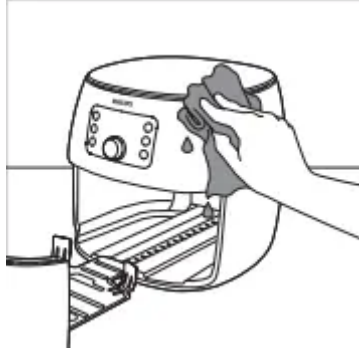

4 Wipe the outside of the appliance with a moist cloth.

Note

- Make sure no moisture remains on the control panel. Dry the control panel with a cloth after you have cleaned it.

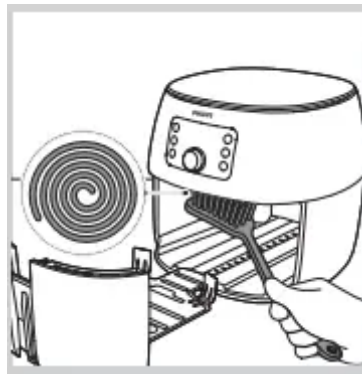



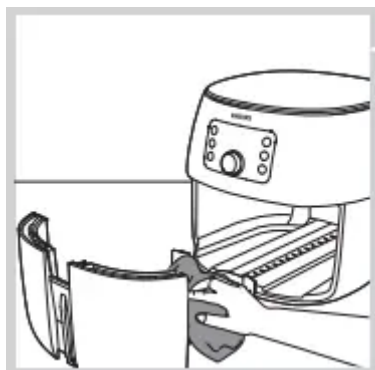



5 Clean the heating element with a cleaning brush to remove any food residues.



6 Clean the inside of the appliance with hot water and a non-abrasive sponge.

Cleaning table

			
	✓	✓	✗
	✓	✓	✗
	✓	✓	✗

Storage

1. Unplug the appliance and let it cool down.
2. Make sure all parts are clean and dry before storing.
3. Insert the cord into the cord storage compartment.

Note

- Always hold the Airfryer horizontally when you carry it. Make sure that you also hold the drawer on the front part of the appliance as it can slide out of the appliance if accidentally tilted downwards. This can lead to damaging of the drawer.
- Always make sure that the removable parts of the Airfryer e.g. removable mesh bottom, etc. are fixed before you carry and/or store it.

Recycling



- This symbol means that this product shall not be disposed of with normal household waste (2012/19/EU).
- Follow your country's rules for the separate collection of electrical and electronic products. Correct disposal helps prevent negative consequences for the environment and human health.

Troubleshooting

This chapter summarizes the most common problems you could encounter with the appliance. If you are unable to solve the problem with the information below, visit [philips/support](https://philips.com/support) for a list of frequently asked questions or contact the Consumer Care Center in your country.

Problem	Possible cause	Solution
<p>The outside of the appliance becomes hot during use.</p>	<p>The heat inside radiates to the outside walls.</p>	<p>This is normal. All handles and knobs that you need to touch during use stay cool enough to touch.</p>
		<p>The pan, basket, fat reducer, and the inside of the appliance always become hot when the appliance is switched on to ensure the food is properly cooked. These parts are always too hot to touch.</p>
		<p>If you leave the appliance switched on for a longer time, some areas get too hot to touch. These areas are marked on the appliance with the following icon:</p>  <p>As long as you are aware of the hot areas and avoid touching them, the appliance is completely safe to use.</p>
<p>My home-made fries do not turn out as I expected.</p>	<p>You did not use the right potato type.</p>	<p>To get the best results, use fresh floury potatoes. If you need to store the potatoes, do not store them in a cold environment like in a fridge. Choose potatoes whose package states that they are suitable for frying.</p>
	<p>The amount of ingredients in the basket is too big.</p>	<p>Follow the instructions in this user manual to prepare home-made fries (see 'Food table for Smart Chef programs' or download the free Airfryer App).</p>
	<p>Certain types of ingredients need to be shaken halfway through the cooking time.</p>	<p>Follow the instructions in this user manual to prepare home-made fries (see 'Food table for Smart Chef programs' or download the free Airfryer App).</p>
<p>The Airfryer does not switch on.</p>	<p>The appliance is not plugged in.</p>	<p>Check if the plug is inserted in the wall outlet properly.</p>

	Several appliances are connected to one outlet.	The Airfryer has a high wattage. Try a different outlet and check the fuses.
After starting a Smart Chef program the appliance stopped the calculation phase	The cooking chamber temperature is too high either because the appliance is pre-heated or has not cooled down sufficiently between two batches.	Keep the drawer open for some minutes to cool it down. Close it and start the Smart Chef program again.
	The drawer is opened during the calculation phase.	Close the drawer and proceed cooking with the manual mode.
	The drawer is not closed properly.	Make sure that the drawer is closed properly.
The appliance has stopped cooking with the Smart Chef program.	The drawer is opened during the calculation phase.	Do not pull out the drawer as long as the appliance is calculating the cooking time, which is indicated by blinking bars on the display.
I see some peeling off spots inside my Airfryer.	Some small spots can appear inside the pan of the Airfryer due to the incidental touching or scratching of the coating (e.g. during cleaning with harsh cleaning tools and/or while inserting the basket).	You can prevent damage by lowering the basket into the pan properly. If you insert the basket at an angle, its side may knock against the wall of the pan, causing small pieces of coating to chip off. If this occurs, please be informed that this is not harmful as all materials used are food-safe.
White smoke comes out of the appliance	You are cooking fatty ingredients and the fat reducer is not put in the pan.	Carefully pour off any excess oil or fat from the pan, place the fat reducer in the pan and then continue cooking.
	The pan still contains greasy residues from previous use.	White smoke is caused by greasy residues heating up in the pan. Always clean the pan, basket and fat reducer thoroughly after every use.
	Breading or coating did not adhere properly to the food.	Tiny pieces of airborne breading can cause white smoke. Firmly press breading or coating to food to ensure it sticks.

	Marinade, liquid or meat juices are splattering in the rendered fat or grease	Pat food dry before placing it in the basket.
<p>My display shows 5 dashes as illustrated in the picture below.</p> 	This is an error code.	<ol style="list-style-type: none"> 1. Unplug the appliance and let it rest for 5 minutes before plugging in again. 2. If your display still shows the dashes, call the Philips service hot line or contact the Consumer Care Center in your country

Warning

This content is compiled from multiple sources and is provided for reference purposes only. It may not be complete or fully applicable to all situations. If you are unable to resolve your issue, please contact the product manufacturer or an authorized service provider for official support.

