

Operating Instructions

About the features of your microwave oven.

Throughout this manual, features and appearance may vary from your model.

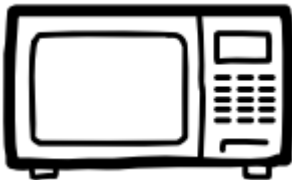
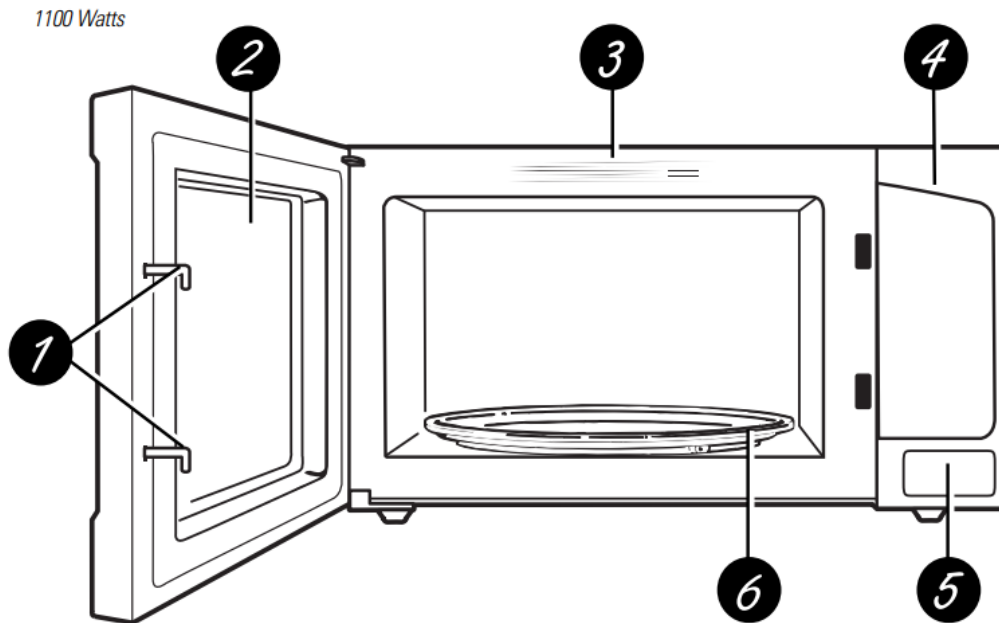

Features of the Oven

1. **Door Latches.**
2. **Window with Metal Shield.** Screen allows cooking to be viewed while keeping microwaves confined in the oven.
3. **Convenience Guide.**
4. **Touch Control Panel and Display.**
5. **Door Latch Release.** Press latch release to open door.
6. **Removable Turntable.** Turntable and support **must** be in place when using the oven. The turntable may be removed for cleaning.

NOTE: Rating plate, oven vent(s) and oven light are located on the inside walls of the microwave oven.

You can microwave by time, with the sensor features or with the auto feature.

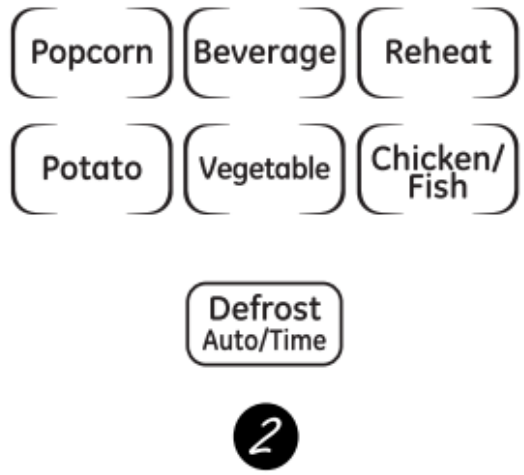
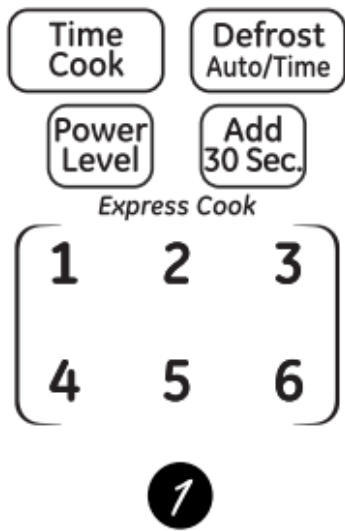

Cooking Controls

Check the Convenience Guide before you begin.



1

Time Features

Press	Enter
Time Cook Press once or twice	Amount of cooking time
Defrost Auto/Time Press twice	Amount of defrosting time
Express Cook	Starts immediately!
Add 30 Sec	Starts immediately!
Power Level	Power level 1-10

2

Sensor Features and Auto Feature

Press	Enter	Option
Popcorn	Starts immediately!	more/less time
Beverage	Starts immediately!	
Reheat	Starts immediately!	more/less time
Chicken/Fish Press once (chicken pieces) Press twice (fish fillets)	Starts immediately!	more/less time
Potato	Starts immediately!	more/less time



<p>Vegetable</p> <p>Press once (fresh vegetables)</p> <p>Press twice (frozen vegetables)</p> <p>Press three times (canned vegetables)</p>	<p>Starts immediately!</p>	<p>more/less time</p> <p>more/less time</p> <p>more/less time (on some models)</p>
<p>Defrost Auto/Time</p>	<p>Food weight</p>	

About changing the power level



The power level may be entered or changed immediately after entering the feature time for Time Cook, Time Defrost or Express Cook. The power level may also be changed during time countdown.

1. Press **Time Cook** or select **Time Defrost**.
2. Enter cooking or defrosting time.
3. Press **Power Level**.
4. Select desired power level 1-10.
5. Press **START**.

Variable power levels add flexibility to microwave cooking. The power levels on the microwave oven can be compared to the surface units on a range. Each power level gives you microwave energy a certain percent of the time. **Power level 7** is microwave energy 70% of the time. **Power level 3** is energy 30% of the time. Most cooking will be done on **High (power level 10)** which gives you 100% power. **Power level 10** will cook faster but food may need more frequent stirring, rotating or turning over. A lower setting will cook more evenly and need less stirring or rotating of the food. Some foods may have better flavor, texture or appearance if one of the lower settings is used. Use a lower power level when cooking foods that have a tendency to boil over, such as scalloped potatoes.

Rest periods (when the microwave energy cycles off) give time for the food to “equalize” or transfer heat to the inside of the food. An example of this is shown with **power level 3**—the defrost cycle. If microwave energy did not cycle off, the outside of the food would cook before the inside was defrosted.

Here are some examples of uses for various power levels:

High 10: Fish, bacon, vegetables, boiling liquids.

Med-High 7: Gentle cooking of meat and poultry; baking casseroles and reheating.

Medium 5: Slow cooking and tenderizing for stews and less tender cuts of meat.

Low 2 or 3: Defrosting; simmering; delicate sauces.

Warm 1: Keeping food warm; softening butter.

About the time features.



Time Cook

Time Cook I

Allows you to microwave for any time up to 99 minutes and 99 seconds.

Power level 10 (High) is automatically set, but you may change it for more flexibility.

1. Press **Time Cook**.
2. Enter cooking time.
3. Change power level if you don't want full power. (Press **Power Level**. Select a desired power level 1-10.)
4. Press **START**.

*You may open the door during **Time Cook** to check the food. Close the door and press **START** to resume cooking.*

Time Cook II

Lets you change power levels automatically during cooking. Here's how to do it:

1. Press **Time Cook**.
2. Enter the first cook time.
3. Change power level if you don't want full power. (Press **Power Level**. Select a desired power level 1-10.)
4. Press **Time Cook** again.
5. Enter the second cook time.
6. Change the power level if you don't want full power. (Press **Power Level**. Select a desired power level 1-10.)
7. **Press START**.

At the end of Time Cook I, Time Cook II counts down.

Cooking Guide for Time Cook

NOTE: Use **power level High (10)** unless otherwise noted.

Vegetable	Amount	Time	Comments
Asparagus <i>(fresh spears)</i>	1 lb.	5 to 8 min., Med-High (7)	In 154-qt. oblong glass baking dish, place 1/4 cup water.
<i>(frozen spears)</i>	10-oz. package	4 to 7 min.	In 1-qt. casserole.
Beans <i>(fresh green)</i>	1 lb. cut in half	10 to 15 min.	In H2-qt. casserole, place 1/2 cup water.
<i>(frozen green)</i>	10-oz. package	4 to 8 min.	In 1-qt. casserole, place 2 tablespoons water.
<i>(frozen lima)</i>	10-oz. package	4 to 8 min.	In 1-qt. casserole, place 1/4 cup water.
Beets <i>(fresh, whole)</i>	1 bunch	16 to 22 min.	In 2-qt. casserole, place 1/2 cup water.
Broccoli <i>(fresh cut)</i>	1 bunch (114 to 112 lbs.)	5 to 9 min.	In 2-qt. casserole, place 1/2 cup water.
<i>(fresh spears)</i>	1 bunch (114 to 112 lbs.)	7 to 11 min.	In 2-qt. oblong glass baking dish, place 1/4 cup water.
<i>(frozen, chopped)</i>	10-oz. package	4 to 7 min.	In 1-qt. casserole.

<i>(frozen spears)</i>	10-oz. package	4 to 7 min.	In 1-qt. casserole, place 3 tablespoons water.
<i>Cabbage (fresh)</i>	1 medium head (about 2 lbs.)	6 to 10 min.	In 1 1/2- or 2-qt. casserole, place 1/4 cup water.
<i>(wedges)</i>		5 to 9 min.	In 2- or 3-qt. casserole, place 1/4 cup water.
<i>Carrots (fresh, sliced)</i>	1 lb.	4 to 8 min.	In 1 1/2-qt. casserole, place 1/4 cup water.
<i>(frozen)</i>	10-oz. package	3 to 7 min.	In 1-qt. casserole, place 2 tablespoons water.
<i>Cauliflower (flowerets)</i>	1 medium head	7 to 11 min.	In 2-qt. casserole, place 1/2 cup water.
<i>(fresh, whole)</i>	1 medium head	7 to 15 min.	In 2-qt. casserole, place 1/2 cup water.
<i>(frozen)</i>	10-oz. package	3 to 7 min.	In 1-qt. casserole, place 2 tablespoons water.



Vegetable	Amount Time Comments
Corn (frozen kernel)	10-oz. package 2 to 6 min. In 1-qt. casserole, place 2 tablespoons water.
Corn on the cob (fresh) (frozen)	1 to 5 ears 1¼ to 4 min. In 2-qt. glass baking dish, place per ear corn. If corn is in husk, use no water; if corn has been husked, add ¼ cup water. Rearrange after half of time. 1 ear 3 to 6 min. Place in 2-qt. oblong glass 2 to 6 ears 2 to 3 min. baking dish. Cover with vented per ear plastic wrap. Rearrange after half of time.
Mixed vegetables (frozen)	10-oz. package 2 to 6 min. In 1-qt. casserole, place 3 tablespoons water.
Peas (fresh, shelled) (frozen)	2 lbs. unshelled 7 to 10 min. In 1-qt. casserole, place ¼ cup water. 10-oz. package 2 to 6 min. In 1-qt. casserole, place 2 tablespoons water.
Potatoes (fresh, cubed, white) (fresh, whole, sweet or white)	4 potatoes 9 to 12 min. Peel and cut into 1-inch cubes. (6 to 8 oz. each) Place in 2-qt. casserole with ½ cup water. Stir after half of time. 1 (6 to 8 oz.) 2 to 4 min. Pierce with cooking fork. Place

	in center of the oven. Let stand 5 minutes.
Spinach (fresh) (frozen, chopped and leaf)	10 to 16 oz. 3 to 6 min. In 2-qt. casserole, place washed spinach. 10-oz. package 3 to 6 min. In 1-qt. casserole, place 3 tablespoons water.
Squash (fresh, summer and yellow) (winter, acorn or butternut)	1 lb. sliced 3 to 5 min. In 1 1/4-qt. casserole, place 1/4 cup water. 1 or 2 squash 5 to 9 min. Cut in half and remove fibrous (about 1 lb. each) membranes. In 2-qt. oblong glass baking dish, place squash cut-side-down. Turn cut-side-up after 4 minutes.

Time Defrost



Allows you to defrost for a selected length of time. See the Defrosting Guide for suggested times. (Auto Defrost explained in the About the auto feature section.)

1. Press Defrost Auto/Time twice.
2. Enter defrosting time.
3. Press START.
4. Turn food over when the oven signals.
5. Press START.

Power level is automatically set at 3, but can be changed. You can defrost small items quickly by raising the power level after entering the time. **Power level 7** cuts the total defrosting time in about half; **power level 10** cuts the total time to approximately 1/3. However, food will need more frequent attention than usual.

At one half of selected defrosting time, the oven signals **TURN**. At this time, turn food over and break apart or rearrange pieces for more even defrosting. Shield any warm areas with small pieces of foil.

A dull thumping noise may be heard during defrosting. This is normal when oven is not operating at **Highpower**.

Defrosting Tips

- Foods frozen in paper or plastic can be defrosted in the package. Closed packages should be slit, pierced or vented **AFTER** food has partially defrosted. Plastic storage containers should be partially uncovered.
- Family-size, prepackaged frozen dinners can be defrosted and microwaved. If the food is in a foil container, transfer it to a microwave-safe dish.
- Foods that spoil easily should not be allowed to sit out for more than one hour after defrosting. Room temperature promotes the growth of harmful bacteria.
- For more even defrosting of larger foods, such as roasts, use Auto Defrost. Be sure large meats are completely defrosted before cooking.
- When defrosted, food should be cool but softened in all areas. If still slightly icy, return to the microwave very briefly, or let it stand a few minutes.

Defrosting Guide

Food	Time	Comments
Breads, Cakes Bread, buns or rolls (1 piece)	1/4 min.	Rearrange after half the time.
Sweet rolls (approx. 12 oz)	2 to 4 min.	
Fish and Seafood Filletts, frozen (1 lb.)	6 to 9 min.	Place block in casserole. Turn over and break up after half the time.
Shellfish, small pieces (1 lb.)	3 to 7 min.	
Fruit Plastic pouch—1 or 2 (10-oz. package)	1 to 5 min.	
Meat Bacon (1 lb.)	2 to 5 min.	Place unopened package in oven. Let stand 5 minutes after defrosting.
Franks (1 lb.)	2 to 5 min.	Place unopened package in oven. Microwave just until franks can be separated. Let stand 5 minutes, if necessary, to complete defrosting.
Ground meat (1 lb.)	4 to 6 min.	Turn meat over after half the time.
Roast: beef, lamb, veal, pork	9 to 13 min. per lb.	Use power level 1.
Steaks, chops and cutlets	4 to 8 min. per lb.	Place unwrapped meat in cooking dish. Turn over after half the time and shield warm areas with foil.

		When finished, separate pieces and let stand to complete defrosting.
Poultry Chicken, broiler-fryer cut up (2/ to 3 lbs.)	14 to 20 min.	Place wrapped chicken in dish. Unwrap and turn over after first half of time. After second half of time, separate pieces and place in cooking dish. Microwave 2 to 4 minutes more, if necessary. Let stand a few minutes to finish defrosting.
Chicken, whole (2'A to 3 lbs.)	20 to 25 min.	Place wrapped chicken in dish. After half the time, unwrap and turn chicken over. Shield warm areas with foil. To complete defrosting, run cold water in the cavity until giblets can be removed.
Cornish hen	7 to 13 min. per lb.	Place unwrapped hen in the oven breast-side-up. Turn over after first half of time. Run cool water in the cavity until giblets can be removed.
Turkey breast (4 to 6 lbs.)	3 to 8 min. per lb.	Place unwrapped breast in microwave-safe dish breast-side-down. After half of time, turn breast-side-up and shield warm areas with foil. Defrost for second half of time. Let stand 1 to 2 hours in refrigerator to complete defrosting.

Express Cook



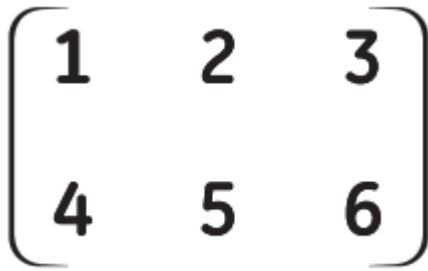

This is a quick way to set cooking time for 1-6 minutes.

Press one of the **Express Cook** pads (from 1 to 6) for 1 to 6 minutes of cooking at **power level 10**. For example, press the **2** pad for 2 minutes of cooking time.

The power level can be changed as time is counting down. Press **Power Level** and enter 1-10.



Add 30 Seconds

You can use this feature two ways:

- It will add 30 seconds to the time counting down each time the pad is pressed.
- It can be used as a quick way to set 30 seconds of cooking time.

About the auto feature.

Auto Defrost



The **Auto/Time Defrost** feature gives you two ways to defrost frozen foods. Press **Defrost Auto/Time** once for **Auto Defrost** or twice for **Time Defrost**.

Use **Auto Defrost** for meat, poultry and fish.

Use **Time Defrost** for most other frozen foods.

Auto Defrost automatically sets the defrosting times and power levels to give even defrosting results for meats, poultry and fish weighing up to six pounds.

1. Press **Defrost Auto/Time** once.
2. Using the **Conversion Guide** below, enter food weight. For example, press pads **1** and **2** for 1.2 pounds (1 pound, 3 ounces).
3. Press **START**.

(**Time Defrost** is explained in the **About the time features** section.)

There is a handy guide located on the inside front of the oven.

- Remove meat from package and place on microwave-safe dish.
- Twice during defrost, the oven signals **TURN**. At each **TURN** signal, turn the food over. Remove defrosted meat or shield warm areas with small pieces of foil.
- After defrosting, most meats need to stand 5 minutes to complete defrosting. Large roasts should stand for about 30 minutes.

Conversion Guide

If the weight of food is stated in pounds and ounces, the ounces must be converted to tenths (.1) of a pound.

<i>Weight of Food in Ounces</i>	<i>Enter Food Weight (tenths of a pound)</i>
<i>1-2</i>	<i>.1</i>
<i>3</i>	<i>.2</i>
<i>4-5</i>	<i>.3</i>
<i>6-7</i>	<i>.4</i>
<i>8</i>	<i>.5</i>
<i>9-10</i>	<i>.6</i>
<i>11</i>	<i>.7</i>
<i>12-13</i>	<i>.8</i>
<i>14-15</i>	<i>.9</i>

About the sensor features.

Humidity Sensor

The ***Sensor Features*** detect the increasing humidity released during cooking. The oven automatically adjusts the cooking time to various types and amounts of food.



Do not use the Sensor Features twice in succession on the same food portion—it may result in severely overcooked or burnt food. If food is undercooked after the countdown, use **Time Cook** for additional cooking time.

- The proper containers and covers are essential for best sensor cooking.



Covered

- Always use microwave-safe containers and cover them with lids or vented plastic wrap. Never use tight sealing plastic containers—they can prevent steam from escaping and cause food to overcook.



Vented

- Be sure the outside of the cooking containers and the inside of the microwave oven are dry before placing food in the oven. Beads of moisture turning into steam can mislead the sensor.



Dry off dishes so they don't mislead the sensor.

Reheat

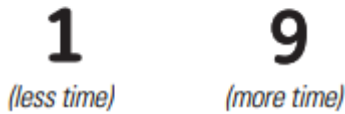

The **Reheat** feature reheats single servings of previously cooked foods or a plate of leftovers.

1. Place covered food in the oven. Press **Reheat**. The oven starts immediately.
2. The oven signals when steam is sensed and the time remaining begins counting down.

Do not open the oven door until time is counting down. If the door is opened, close it and press **START** immediately.

After removing food from the oven, stir, if possible, to even out the temperature. Reheated foods may have wide variations in temperature. Some areas may be extremely hot.

If food is not hot enough after the countdown, use **Time Cook** for additional reheating time.

Some Foods Not Recommended for Use With Reheat

It is best to use **Time Cook** for these foods:

- Bread products.
- Foods that must be reheated uncovered.
- Foods that need to be stirred or rotated.
- Foods calling for a dry look or crisp surface after reheating.

Sensor Cooking



Sensor cooking gives you easy, automatic results with a variety of foods (see the Cooking Guide below)

Vegetables, Potatoes, Fish, Chicken Pieces

1. Place covered food in the oven. Press the food pad. For vegetables, press the **Vegetable** pad once for fresh vegetables, twice for frozen vegetables or three times

for canned vegetables. For chicken or fish, press the **Chicken/Fish** pad once for chicken pieces or twice for fish. The oven starts immediately.

2. The oven signals when steam is sensed and the time remaining begins counting down. Turn or stir the food if necessary.

Do not open the oven door until time is counting down. If the door is opened, close it and press **START** immediately.

If food is undercooked after the countdown, use **Time Cook** for additional cooking time.

How to Change the Automatic Settings (automatic settings for canned vegetables cannot be adjusted on some models):

You can adjust the cooking time for all foods to suit your personal taste.

To reduce time by 10%:

Press **1** within 30 seconds after pressing the food pad.

To add 10% to cooking time:

Press **9** within 30 seconds after pressing the food pad.

Cooking Guide

Food Type	Amount	Comments
Canned Vegetables	4-16 oz	Cover with lid or vented plastic wrap.
Frozen Vegetables	4-16 oz	Follow package instructions for adding water. Cover with lid or vented plastic wrap.
Fresh Vegetables	4-16 oz	Add 1/4 cup water per serving. Cover with lid or vented plastic wrap.
Potatoes	1/2-2 lbs	Pierce skin with fork. Place potatoes on the turntable.
Fish	4-16 oz	Cover with vented plastic wrap.
Chicken Pieces	1-8 pieces	Cover with vented plastic wrap.

About the other features.



Help

The **Help** pad displays feature information and helpful hints. Press **Help**, then select a feature pad.

Clock

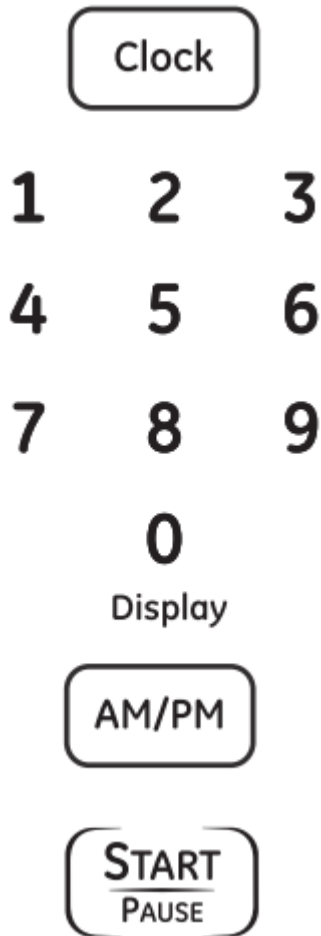

Press to enter the time of day or to check the time of day while microwaving.

1. Press Clock.
2. Enter time of day.
3. Select AM or PM.
4. Press START or Clock.



Scroll Speed

The scroll speed of the display can be changed. Press and hold the **AM/PM** pad about 3 seconds to bring up the display. Select 1-5 for slow to fast scroll speed.



Start/Pause

In addition to starting many functions, **START/PAUSE** allows you to stop cooking without opening the door or clearing the display.

Cooking Complete Reminder

To remind you that you have food in the oven, the oven will display **FOODIS READY** and beep once a minute until you either open the oven door or press **CLEAR/OFF**.



Child Lock-Out

You may lock the control panel to prevent the microwave from being accidentally started or used by children.

To lock or unlock the controls, press and hold **CLEAR/OFF** for about three seconds. When the control panel is locked, **LOCKED** will appear in the display.



Sound Level

The beeper sound level can be adjusted. Press **Beeper Volume**. Choose 0-3 for mute to loud.

Timer On/Off



Timer On/Off operates as a minute timer and can be used at any time, even when the oven is operating.

1. Press **Timer On/Off**.
2. Enter time you want to count down.
3. Press **Timer On/Off** to start.

When time is up, the oven will signal. To turn off the timer signal, press **Timer On/Off**.

NOTE: The timer indicator will be lit while the timer is operating.



To turn the clock display on or off, press and hold **0** for about 3 seconds. The **Display On/Off** feature cannot be used while a cooking feature is in use.



For best cooking results, leave the turntable on.

It can be turned off for large dishes. Press **Turntable On/Off** to turn the turntable on or off.

Sometimes the turntable can become too hot to touch. Be careful touching the turntable during and after cooking.

Optional accessories.

Available at extra cost from your GE supplier. Choose the appropriate Installation Kit below to convert this oven to a built-in wall oven.

For 27" installations: Model

JEB1860DMBB

JEB1860DMCC

JEB1860DMWW

JEB1860SMSS

For 30" installations: Model

JEB1860DMBB

JEB1860DMCC

JEB1860DMWW

JEB1860SMSS

Kit

JX2027DMBB

JX2027DMCC

JX2027DMWW

JX2027SMSS

Kit

JX2030DMBB

JX2030DMCC

JX2030DMWW

JX2030SMSS

Microwave terms.



Term	Definition
Arcing	<p>Arcing is the microwave term for sparks in the oven. Arcing is caused by:</p> <ul style="list-style-type: none"> • metal or foil touching the side of the oven. • foil that is not molded to food (upturned edges act like antennas). • metal such as twist-ties, poultry pins, gold-rimmed dishes. • recycled paper towels containing small metal pieces.
Covering	<p>Covers hold in moisture, allow for more even heating and reduce cooking time. Venting plastic wrap or covering with wax paper allows excess steam to escape.</p>
Shielding	<p>In a regular oven, you shield chicken breasts or baked foods to prevent over-browning. When microwaving, you use small strips of foil to shield thin parts, such as the tips of wings and legs on poultry, which would cook before larger parts.</p>



<p>Standing Time</p>	<p>When you cook with regular ovens, foods such as roasts or cakes are allowed to stand to finish cooking or to set. Standing time is especially important in microwave cooking. Note that a microwaved cake is not placed on a cooling rack.</p>
<p>Venting</p>	<p>After covering a dish with plastic wrap, you vent the plastic wrap by turning back one corner so excess steam can escape.</p>

Care and cleaning of the microwave oven.



Helpful Hints

An occasional thorough wiping with a solution of baking soda and water keeps the inside fresh.

Unplug the cord before cleaning any part of this oven.

How to Clean the Inside

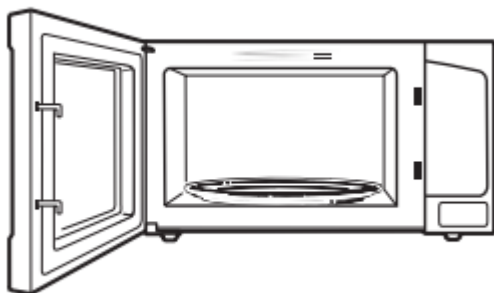

Walls, Floor, Inside Window, Metal and Plastic Parts on the Door

Some spatters can be removed with a paper towel, others may require a damp cloth. Remove greasy spatters with a sudsy cloth, then rinse with a damp cloth. Do not use abrasive cleaners or sharp utensils on oven walls.

To clean the surface of the door and the surface of the oven that come together upon closing, use only mild, nonabrasive soaps or detergents using a sponge or soft cloth. Rinse with a damp cloth and dry.

Never use a commercial oven cleaner on any part of your microwave.

Removable Turntable and Turntable Support



To prevent breakage, do not place the turntable into water just after cooking. Wash it carefully in warm, sudsy water or in the dishwasher. The turntable and support can be broken if dropped. Remember, do not operate the oven without the turntable and support in place.

How to Clean the Outside

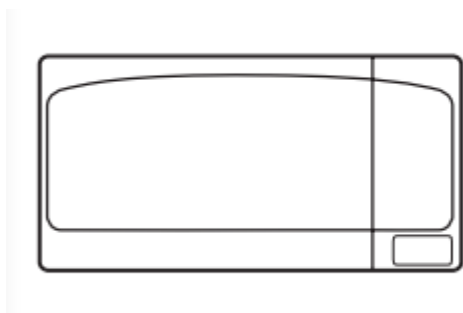

Do not use cleaners containing ammonia or alcohol on the microwave oven. Ammonia or alcohol can damage the appearance of the microwave.

Case

Clean the outside of the microwave with a sudsy cloth. Rinse and then dry. Wipe the window clean with a damp cloth.

Control Panel and Door

Wipe with a damp cloth. Dry thoroughly. Do not use cleaning sprays, large amounts of soap and water, abrasives or sharp objects on the panel—they can damage it. Some paper towels can also scratch the control panel.

Door Surface

It's important to keep the area clean where the door seals against the microwave. Use only mild, non-abrasive detergents applied with a clean sponge or soft cloth. Rinse well.

Stainless Steel (on some models)

To clean the surface, use hot soapy water, then rinse and dry. Do not use steel wool pads or other abrasive cleaners. They will scratch the surface.

Power Cord

If the cord becomes soiled, unplug and wash with a damp cloth. For stubborn spots, sudsy water may be used, but be certain to rinse with a damp cloth and dry thoroughly before plugging cord into outlet.

Troubleshooting Tips

Before you call for service...

Troubleshooting Tips

Save time and money! Review the charts on the following pages first and you may not need to call for service.

<i>Problem</i>	<i>Possible Causes</i>	<i>What To Do</i>
<i>Oven will not start</i>	A fuse in your home may be blown or the circuit breaker tripped.	Replace fuse or reset circuit breaker.
	Power surge.	Unplug the microwave oven, then plug it back in.
	Plug not fully inserted into wall outlet.	Make sure the 3-prong plug on the oven is fully inserted into wall outlet.
<i>Control panel lighted, yet oven will not start</i>	Door not securely closed.	Open the door and close securely.
	START pad not pressed after entering cooking selection.	Press START .
	Another selection entered already in oven and CLEAR/OFF pad not pressed to cancel it.	Press CLEAR/OFF .
	Cooking time not entered after pressing Time Cook.	Make sure you have entered cooking time after pressing Time Cook .
	CLEAR/OFF was pressed accidentally.	Reset cooking program and press START .
	Food weight not entered after	Make sure you have entered food weight after selecting Auto Defrost .

	selecting Auto Defrost .	
"LOCKED" appears in display	The control has been locked. (When the control panel is locked an L will be displayed.)	Press and hold CLEAR/OFF for about three seconds to unlock the control.
"SENSOR ERROR" appears in display	During Popcorn, Reheat, Beverage, Chicken/Fish, Potato or Vegetable program, the door was opened before steam could be detected.	Close the door, press CLEAR/OFF and begin again.
	Steam was not detected in maximum amount of time.	Use Time Cook to heat for more time.
Food amount too large for Sensor Reheat	Sensor Reheat is for single servings of recommended foods.	Use Time Cook for large amounts of food.

Things That Are Normal With Your Microwave Oven

- Steam or vapor escaping from around the door.
- Light reflection around door or outer case.
- Dimming oven light and change in the blower sound at power levels other than high.
- Dull thumping sound while oven is operating.
- TV/radio interference might be noticed while using the microwave. Similar to the interference caused by other small appliances, it does not indicate a problem with the microwave. Plug the microwave into a different electrical circuit, move the radio or TV as far away from the microwave as possible or check the position and signal of the TV/radio antenna.

Warning

This content is compiled from multiple sources and is provided for reference purposes only. It may not be complete or fully applicable to all situations. If you are unable to resolve your issue, please contact the product manufacturer or an authorized service provider for official support.

Document generated by [ManualsFile](#)