

Before Using the Product

Cleaning

High-glossy models can develop white stains on the surface if an ultrasonic wave humidifier is used nearby.

- Contact your nearest Samsung Customer Service Center if you want to clean the inside of the product (Service fee will be charged.)

Do not press the product screen with hands or other objects. There is a risk of damaging the screen.

- Exercise care when cleaning as the panel and exterior of advanced LCDs are easily scratched.

Take the following steps when cleaning.

1. Power off the product and PC.
2. Disconnect the power cord from the product.
 - Hold the power cable by the plug and do not touch the cable with wet hands. Otherwise, an electric shock may result.
3. Wipe the product with a clean, soft and dry cloth. Wet a soft cloth in water, wring it out well, and then use the cloth to wipe the exterior of the product clean.
 - Do not apply a cleaning agent that contains alcohol, solvent, or surfactant to the product. – Do not spray water or detergent directly on the product.
4. Connect the power cord to the product when cleaning is finished.
5. Power on the product and PC.

Correct posture to use the product



Use the product in the correct posture as follows:

- Straighten your back.
- Allow a distance of 45 to 50cm between your eye and the screen, and look slightly downward at the screen.
- Keep your eyes directly in front of the screen.
- Adjust the angle so light does not reflect on the screen.
- Keep your forearms perpendicular to your upper arms and level with the back of your hands.
- Keep your elbows at about a right angle.
- Adjust the height of the product so you can keep your knees bent at 90 degrees or more, your heels attached to the floor, and your arms lower than your heart.
- Do the Eye exercises or blink frequently, then eye fatigue will be relieved.

Preparations





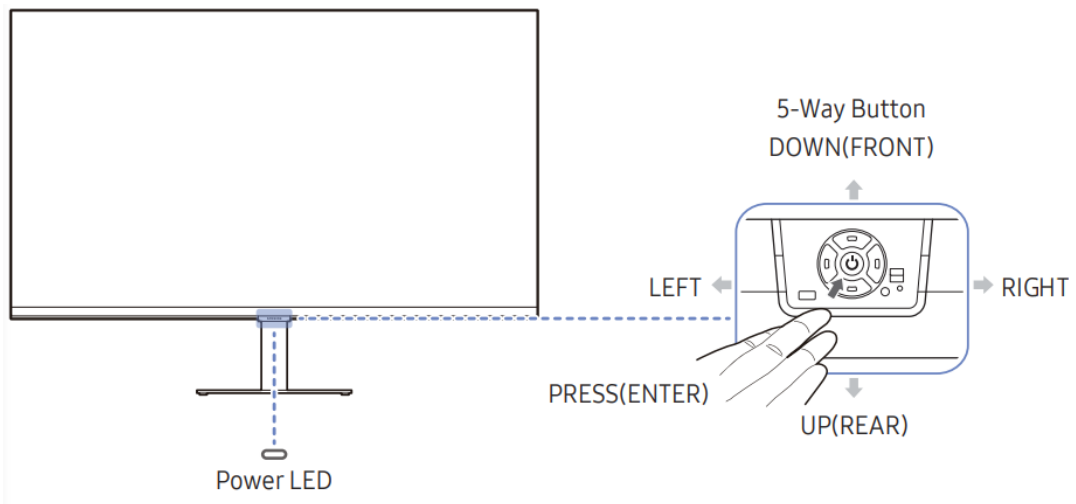

Control Panel

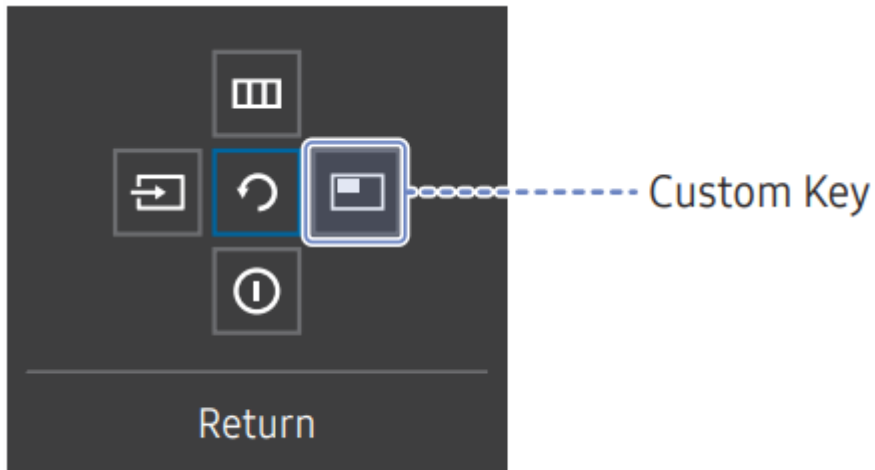
- The color and shape of parts may differ from what is shown. Specifications are subject to change without notice to improve quality

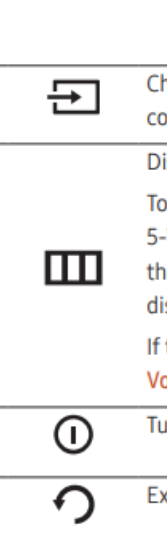

Function Key Guide



Parts		Description
5-Way Button		Multi directional button that helps navigate.
Power LED		This LED is power status indicator. — You can select the power LED operation to be enabled or disabled on the menu screen. ( → System → Power LED On)
Function Key Guide		To use the Function Key Guide, press the 5-Way Button when the screen is turned on. <ul style="list-style-type: none"> • Custom Key is used to directly access the function set in Setup Custom Key. • Setup Custom Key
Custom Key		 — Go to  → System → Setup Custom Key and change the custom key.
Source		Changes the input source. A message will appear on the top left corner of the screen if the input source has been changed.
Menu		Displays the main on-screen menu. To enable or disable the menu lock, move to the next step (move the 5-Way Button to the right) with the "Menu" displayed, and then push the 5-Way Button to the left for 10 seconds until the menu screen disappears. If the menu lock is enabled, Brightness, Contrast, Eye Saver Mode, Volume and Information are available.
Power Off		Turns off the product.
Return		Exits from the menu page.

Direct Key Guide

- On the Direct Key Guide screen, the following menu options appear when the product screen is switched on or the input source is changed.

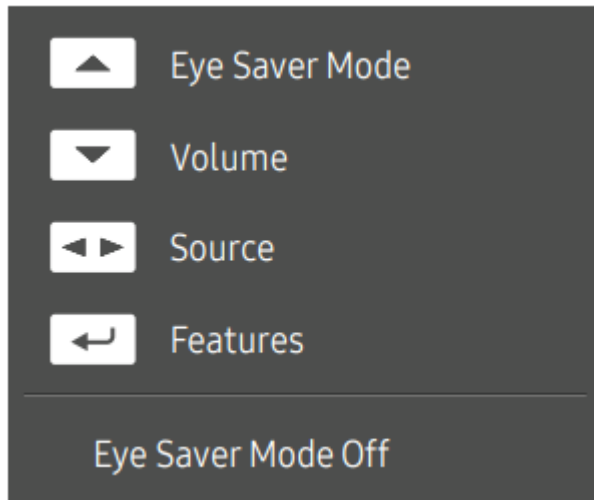

- The Direct Key Guide screen shows if Eye Saver Mode is enabled. (Off, Low, High)
- When the product not displays the OSD menu, the 5-Way Button could be used as below.
 - UP: Adjust Brightness, Contrast, Eye Saver Mode.
 - DOWN: Adjust Volume, Mute.
 - LEFT/RIGHT: Adjust Source.
 - PRESS(ENTER): Display Function Key Guide.

Connecting and Using a Source Device

Read below before connecting the product.

1. Before connecting the product, check the shapes of both ports of the supplied signal cables and the shapes and locations of the ports on the product and external device.
2. Before connecting the product, make sure you remove the power cables from both the product and the external device to prevent damage to the product due to a short circuit or over current.
3. After all signal cables have been properly connected, connect the power cables back to the product and the external device.
4. After connecting is completed, make sure you read the manuals to acquaint yourself with the product functions, precautions and other information required to use the product properly.
 - Connecting parts may differ in different products.
 - Provided ports may vary depending on the product.

Ports

- The functions available may vary depending on the product model. The color and shape of parts may differ from what is shown. Specifications are subject to change without notice to improve quality. Refer to the actual product.

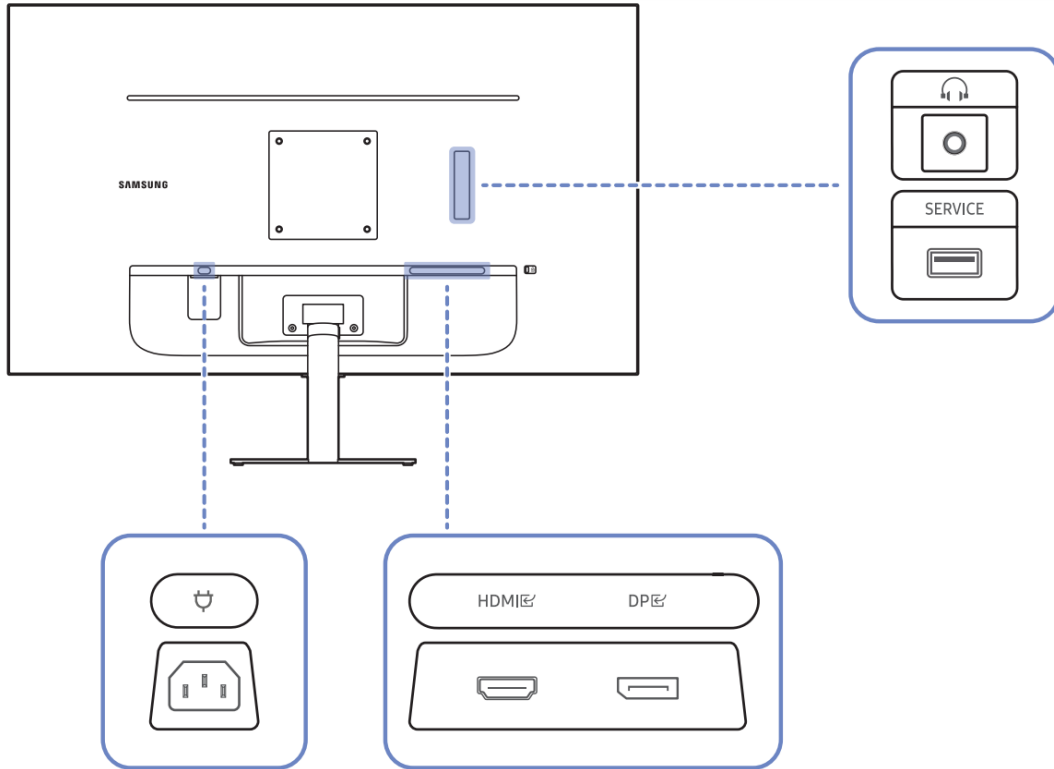

Port	Description
	Connect to an audio output device such as headphones.
	Connect to a USB device.
	Connects to a source device using an HDMI cable or HDMI-DVI cable.
	Connects to a PC using a DP cable.
	Connect the power cord for product.

Connecting and Using a PC

Select a connection method suitable for your PC.

Connection Using the HDMI Cable



- It is recommended to use the HDMI cable provided as components. If not provided, be sure to use authorized cable for HDMI cable connections. If you use a unauthorized HDMI cable, the image quality may be degrade.

Connection Using an HDMI-DVI Cable



- When using HDMI-DVI cable, audio may not be supported according to source device.
- The optimum resolution may not be available with an HDMI-DVI cable

Connection Using an DP Cable



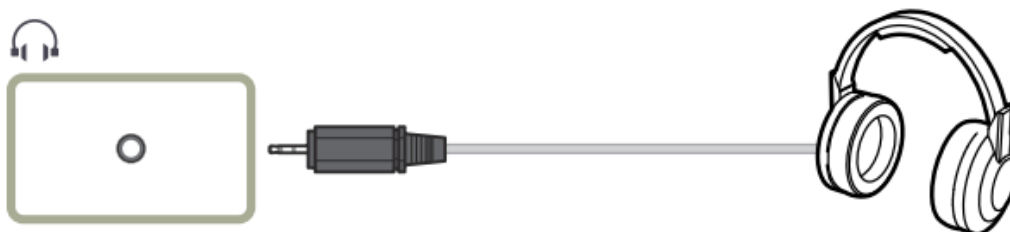

- It is recommended to use the DP cable provided as an accessory. If not provided, be sure to use a DP cable of 1.5 m or below.

Connecting to headphones or earphones Connecting the Power

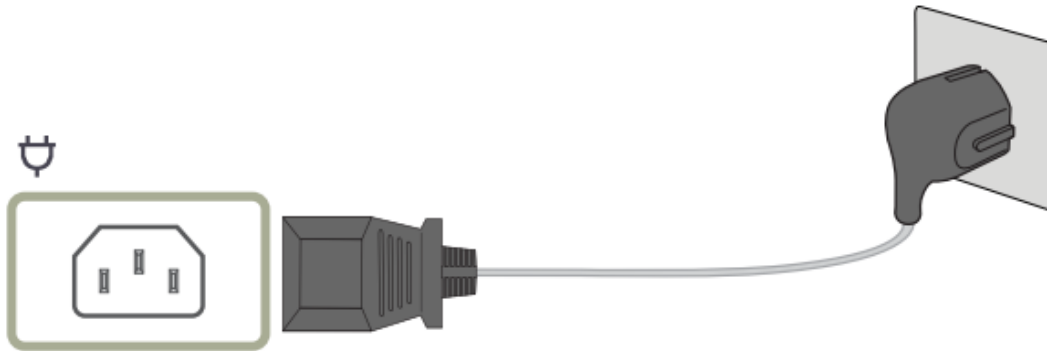

Connecting the Power



To use the product, connect the power cable to a power outlet and the  port on the product.

- The input voltage is switched automatically

Tidying Up the Connected Cables

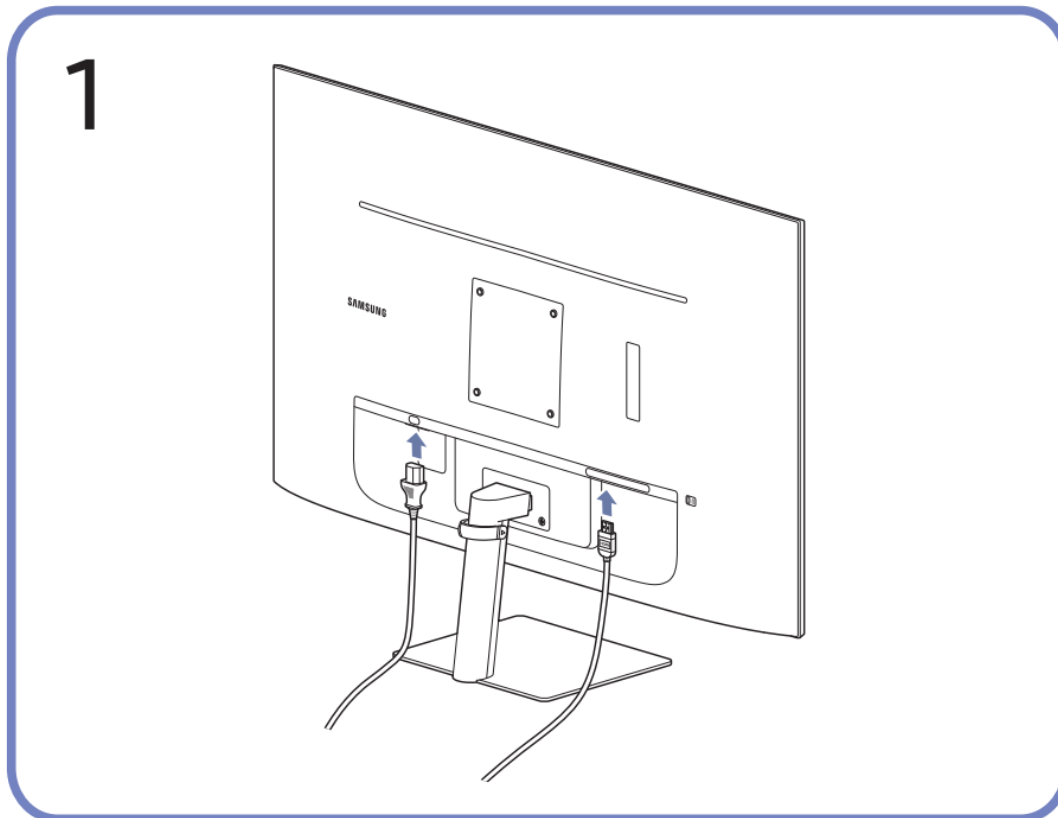

- Connect the corresponding cables.

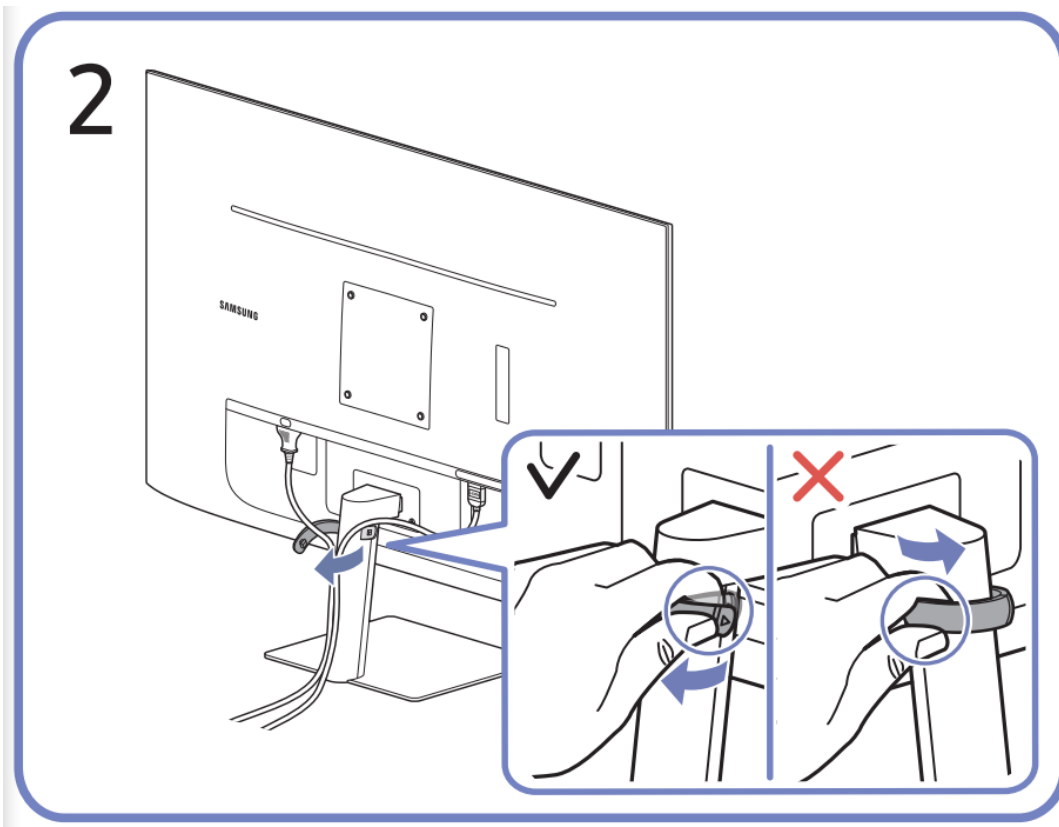

- Pull the right side of the HOLDER-STAND CABLE to remove from the stand. The left side of the HOLDER-STAND CABLE can be damaged when pulled forcibly

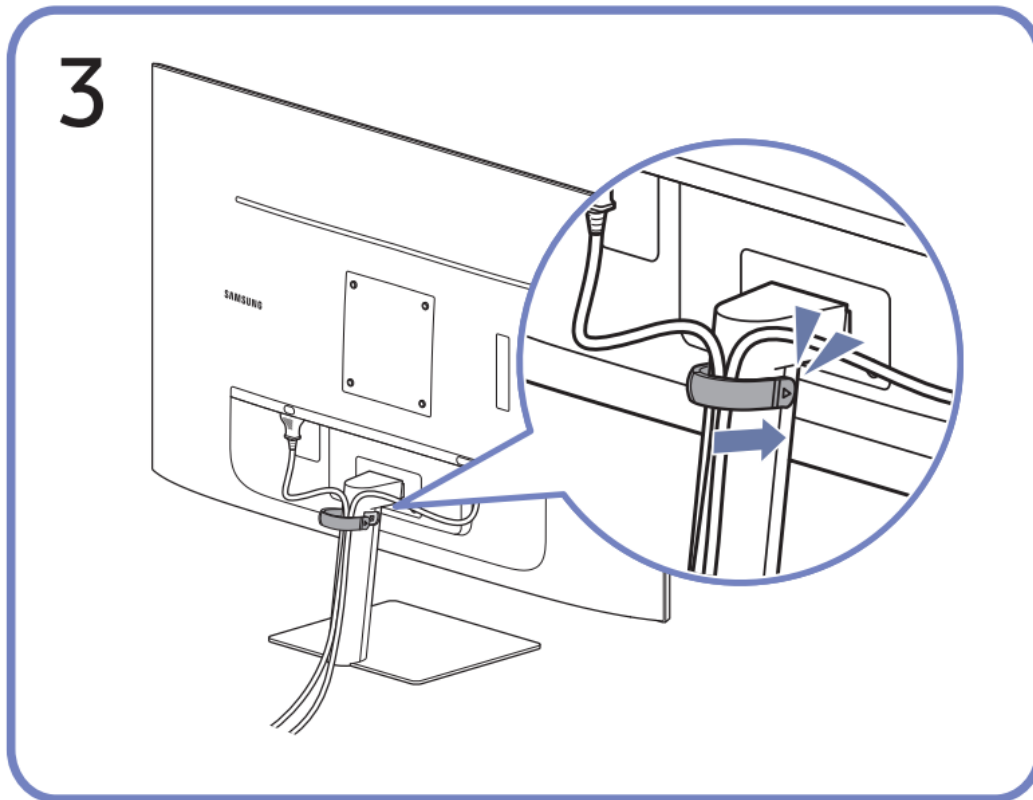

- Put both cables in the cable holder on the stand (HOLDER-STAND CABLE) to organize the cables, as shown in the figure. Assembly is complete.

Setting Optimum Resolution

An information message about setting optimum resolution will appear if you power on the product for the first time after purchase.

Select a language on information message and change the resolution on your PC to the optimum setting.

- If the optimum resolution is not selected, the message will appear up to three times for a specified time even when the product is turned off and on again.
- If you want to set the optimum resolution for your computer. Please refer to (Q&A) → “How can I change the resolution?”

List of graphic cards supporting HDR10

HDR10 is accessible only on Windows 10 systems equipped with graphic cards that support Play Ready 3.0 Digital Rights Management (for protected HDR content). Use graphic cards listed below for HDR10.

- NVIDIA GeForce 1000 series or higher
- AMD Radeon™ RX 400 series or higher

- Intel UHD Graphics 600 series or higher
 - Graphic cards that support hardware-accelerated 10-bit video decoding for HDR video codecs are recommended.

Menu

Function Key Guide → 

The functions available may vary depending on the product model. The color and shape of parts may differ from what is shown. Specifications are subject to change without notice to improve quality

Picture

2nd

3rd

Description

Picture Mode

This menu provides an optimum picture quality suitable

— This menu is not available when **Eco Saving Plus** is

— This menu is not available when **Game Mode** is enab

— This menu is not available when **Eye Saver Mode** is

— This menu is not available when **PIP/PBP Mode** is en

In **PC** mode

- **Custom**: Customize the contrast and brightness
- **Standard**: Obtain a picture quality suitable for
- **Cinema**: Obtain the brightness and sharpness content.
- **Dynamic Contrast**: Obtain balanced brightness
- **High Bright**: Maximise the screen brightness.
 - **sRGB**: Adjust the color system to sRGB

In **AV** mode

When the external input is connected through HDMI, DP or DVI, automatic picture settings (**Dynamic**, **Standard**, **Movie** or **Custom**) will activate either **Dynamic**, **Standard**, **Movie** or **Custom**. Select your personalized picture settings.

- **Dynamic**: Select this mode to view a sharper picture
- **Standard**: Select this mode when the surrounding environment is bright
- **Movie**: Select this mode when the surrounding environment is dark to reduce eye fatigue.
- **Custom**: Select this mode when you want to adjust the picture settings

— The input source is 480p, 576p, 720p or 1080p and the TV does not support all of these signals.)

Brightness

You can adjust the general brightness of the picture. (Range: 0 to 100. Higher values are brighter.

— This menu is not available when **Picture Mode** is set to **Custom**

— This menu is not available when **Eco Saving Plus** is enabled or **Game Mode** is enabled.

Contrast

Adjust the contrast between the objects and background.

A higher value will increase the contrast to make the objects clearer.

— This menu is not available when **Picture Mode** is set to **Dynamic**.

— This menu is not available when **Game Mode** is enabled.

— This menu is not available when **PIP/PBP Mode** is enabled.

Sharpness

Make the outline of objects more clear or blurry. (Range: 0 to 100. Higher values are clearer.)

— This option is not available when **Picture Mode** is in **Dynamic**.

— This menu is not available when **Game Mode** is enabled.

— This menu is not available when **PIP/PBP Mode** is enabled.

Color

Adjust the tint of the screen.

- **Color Tone**: Select a color tone that best suits your environment.
- **Red**: Adjust the red saturation level. Values close to 0 are less saturated.
- **Green**: Adjust the green saturation level. Values close to 0 are less saturated.
- **Blue**: Adjust the blue saturation level. Values close to 0 are less saturated.
- **Gamma**: Adjust the middle level of luminance.
- **Saturation**: Adjust the saturation level. Values close to 0 are less saturated.

— This menu is not available when **Picture Mode** is set to **Dynamic**.

— This menu is not available when **Game Mode** is enabled.

— This menu is not available when **Eye Saver Mode** is enabled.

— This menu is not available when **PIP/PBP Mode** is enabled.

Black Level

If a DVD player or set-top box etc is connected to the product, (color degradation, black level, etc.) may occur, depending on the source.

In such case, **Black Level** can be used to adjust the image.

- **Normal / Low**

— This function is only available in **HDMI** mode.

— This menu is not available when **PIP/PBP Mode** is enabled.

— **Black Level** may not be compatible with some sources.

— The **Black Level** feature is only activated at a certain resolution: 720p @ 60 Hz and 1080p @ 60 Hz.

Response Time

Accelerate the panel response rate to make video appear

— Use **Standard** mode when not playing a video or game

— This menu is not available when **PIP/PBP Mode** is en

Game Mode

Configure the product screen settings for game mode.

Use this feature when playing games on a PC or when a

connected.

— This menu is not available when **Eye Saver Mode** is

— This menu is not available when **sRGB** is enabled.

— When the product turns off, enters power-saving mod

even if it is set to **On**.

— If you want to keep **Game Mode** enabled all the time

— This menu is not available when **PIP/PBP Mode** is en

Screen Ratio

Change the picture size.

— This menu is not available when **PIP/PBP Mode** is en

In **PC** mode

- **Auto / Wide**

In **AV** mode

- **4:3 / 16:9 / Screen Fit**

— The function may not be supported depending on the

— Changing the **Screen Ratio** is available when the foll

— The input source is 480p, 576p, 720p or 1080p and

support all of these signals.).

— This can only be set when the external input is con

AV.

Screen Adjustment

Adjust the position of the screen or increase the picture

— This menu is not available when **PIP/PBP Mode** is enabled.

- **H-Position**: Move the screen to the left or right.
- **V-Position**: Move the screen up or down.

— Connection Using the HDMI, DP Cable

— This menu is only available when **Screen Ratio** is set to 16:9.

When a 480p, 576p, 720p or 1080p signal is input in

Screen Fit to adjust horizontal position and vertical p

Eye Care

2nd	3rd	Description
Adaptive Picture		Optimizes brightness and provides the best picture quality for the content you're viewing. — This option is available when Eco Sensor Mode is set to On. — This menu is not available when sRGB is enabled.
Min. Backlight		Minimizes screen backlight when running Adaptive Picture. — This menu is not available when sRGB is enabled.
Eye Saver Mode		Set to an optimum picture quality suitable for eye relaxation.

PIP/PBP



2nd

3rd

Description

PIP/PBP Mode

Turn PIP/PBP Mode on or off.

Mode Type

Select the size and aspect ratio of the sub-screen.

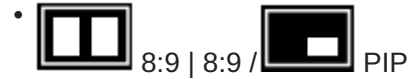









Eye Saver Mode

Screen Size Select sub-screen size.



◦ This option is available when Mode

Screen Position		<p>Select the position of the sub-screen from the available</p> <ul style="list-style-type: none"> •  /  /  /  <p>◦ This option is available when Mod</p>
Sound Source		<p>Set which screen you want to hear the sound for.</p> <p>In PIP mode</p> <ul style="list-style-type: none"> •  /  <p>In PBP mode</p> <ul style="list-style-type: none"> •  / 
Source		Select the source for each screen
Screen Ratio		<p>Choose the size and aspect ratio of the picture display</p> <p>In PC mode</p> <ul style="list-style-type: none"> • Auto / Wide



		<p>In AV mode</p> <ul style="list-style-type: none"> • 4:3 / 16:9 / Screen Fit <ul style="list-style-type: none"> ◦ The function may not be supported ◦ Changing the Screen Ratio is available <ul style="list-style-type: none"> ▪ The input source is 480p or lower normally (Not every model) ▪ This can only be used with HDMI, DP and DVI
Contrast		Adjust the contrast level. Values closer to 100 mean a higher contrast.

OnScreen Display

2nd	3rd	Description
Transparency		Set the transparency for the menu windows.
Position		<ul style="list-style-type: none"> • H-Position: Move the menu position to the left or right • V-Position: Move the menu position up or down
Language		<p>Set the menu language.</p> <p>— A change to the language setting will only be applied when the TV is powered off.</p>
Display Time		Set how long the menu window will remain on screen for.
Display Time Info		Show the time left until the menu window disappears. M: minutes, S: seconds.
Enlarge		Enlarge the size of the Menu area.

System



2nd

3rd

DisplayPort Ver.

Input Port Ver.

Volume

Eco Saving Plus

Off Timer Plus	Off Timer
-----------------------	------------------



	Eco Timer
--	------------------

PC/AV Mode

Auto Source Switch

Key Repeat Time

Power LED On

Accessibility

Setup Custom Key

Eco Sensor Mode

Installing the Software

Easy Setting Box



Easy Setting Box enables users to use the product by partitioning multiple sections.

To install the latest version of Easy Setting Box, download it from the Samsung website (samsung.com).

- The software may not work properly if you do not restart the PC after the installation.
- The Easy Setting Box icon may not appear depending on the PC system and the product specifications.
- If the shortcut icon does not appear, press the F5 key.

Restrictions and Problems with the Installation

- The Easy Setting Box installation may be affected by the Graphics Card, Motherboard and the Networking Environment.

System Requirements

OS	Hardware
<ul style="list-style-type: none">• Windows 7 32Bit/ 64Bit• Windows 8 32Bit/ 64Bit• Windows 8.1 32Bit/ 64Bit• Windows 10 32Bit/ 64Bit	<ul style="list-style-type: none">• At least 32MB of memory• At least 60MB of free space on the hard disk drive

Driver Installation

To install the latest version of the product driver, download it from the Samsung website (samsung.com).

- You can set the optimum resolution and frequency for this product by installing the corresponding drivers

Troubleshooting Guide

Requirements Before Contacting Samsung Customer Service Center

- Before calling Samsung Customer Service Center, test your product as follows. If the problem persists, contact Samsung Customer Service Center.

Product diagnosis (Screen issue)

- If a problem occurs with the product screen, run Self Diagnosis to check that the product is working properly.



Checking the Resolution and Frequency

If a resolution that is not supported (see the Standard Signal Mode Table) is selected, the Not Optimum Mode message may appear for a short time or the screen may not be displayed properly.

- The displayed resolution may vary, depending on the PC system settings and cables.

Check the following.

Installation issue

Blank spaces are found on all four sides of the screen when an HDMI or HDMI-DVI cable is connected to the product and PC.



- The blank spaces found on the screen have nothing to do with the product.
- Blank spaces on the screen are caused by the PC or graphics card. To resolve the problem, adjust the screen size in the HDMI or DVI settings for the graphics card.
- If the graphics card settings menu does not have an option to adjust the screen size, update the graphics card driver to the latest version.
- (Please contact the graphics card or PC manufacturer for further details about how to adjust the screen settings.)

Screen issue

The power LED is off. The screen will not switch on.

- Check that the power cable is connected properly.
- If a problem occurs with the product screen, run Self Diagnosis to check that the product is working properly.

The message Check the cable connection and the settings of the source device. appears.

- Check that the cable is properly connected to the product.
- Check that the device connected to the product is powered on.
- Check the PC/AV Mode status. ( → System → PC/AV Mode → DisplayPort: PC or AV / HDMI: PC or AV.)
- Set the connected HDMI or DisplayPort version. (HDMI:  → System → Input Port Ver. → 1.4 or 2.0, DisplayPort:  → System → DisplayPort Ver. → 1.1 or 1.2†)

Not Optimum Mode is displayed.

- This message appears when the signal from the graphics card exceeds the maximum resolution or frequency for the product.
- Change the maximum resolution and frequency to suit the product performance, referring to Standard Signal Mode Table

The images on the screen look distorted.

- Check the cable connection to the product.

The screen is not clear. The screen is blurry.

- Remove any accessories (video extension cable, etc.) and try again.
- Set the resolution and frequency to the recommended level.

The screen appears unstable and shaky. There are shadows or ghost images left on the screen.

- Check that the resolution and frequency for the PC are within the range of resolution and frequency compatible with the product. Next, if required, change the settings, referring to Standard Signal Mode Table in this manual and the Information menu on the product.

The screen is too bright.

- The screen is too dark. Adjust Brightness and Contrast.

Screen color is inconsistent.

Change the Color settings.

- *The colors on the screen have a shadow and are distorted. Change the Color settings.*

White does not really look white.

- Change the Color settings.

There is no image on the screen and the power LED blinks every 0.5 to 1 second.

- Check the cable connection between the product and PC, and ensure the connectors are locked.
- Press any key on the keyboard or move the mouse to return to normal operating mode.
- The product is operating in power-saving mode.

Text is blurry.

- If using a Windows OS (e.g. Windows 7, Windows 8, Windows 8.1 or Windows 10): Go to Control Panel → Fonts → Adjust ClearType text and change Turn on ClearType.

Video playback is choppy.

- Playback of high-definition large video files can be choppy. This may be because the video player is not optimized for the PC resource.
- Try playing the file on another video player.

Sound issue

There is no sound.

- Re-check the condition of the connected headphone or earphone and/or adjust the volume.

- Check the volume.
- Check whether the volume of the product or the source device is set to mute.

The volume is too low.

- Adjust the volume.
- If the volume is still low after turning it up to the maximum level, adjust the volume on your PC sound card or software program.

Video is available but there is no sound.

- Sound cannot be heard if an HDMI-DVI cable or DVI cable is used to connect the input device.
- Connect the device using an HDMI cable or a DP cable.

Source device issue

A beeping sound is heard when my PC is booting.

- If a beeping sound is heard when your PC is booting, have your PC serviced.

Q & A

Refer to the user manual for your PC or graphics card for further instructions on adjustment.

How can I change the frequency?

Set the frequency on your graphics card.

- Windows 7: Go to Control Panel → Appearance and Personalization → Display → Screen Resolution → Advanced settings → Monitor, and adjust Screen Refresh Rate under Monitor settings.
- Windows 8(Windows 8.1): Go to Settings → Control Panel → Appearance and Personalization → Display → Screen Resolution → Advanced settings → Monitor, and adjust Refresh rate under Monitor settings
- Windows 10: Go to Settings → System → Display → Advanced display settings → Display adapter properties → Monitor, and adjust Screen refresh rate under Monitor settings.

How can I change the resolution?

- Windows 7: Go to Control Panel → Appearance and Personalization → Display → Screen Resolution → Adjust Resolution.
- Windows 8(Windows 8.1): Go to Settings → Control Panel → Appearance and Personalization → Display → Adjust Resolution, and adjust the resolution.
- Windows 10: Go to Settings → System → Display → Advanced display settings, and adjust the resolution.

How do I set power-saving mode?

- Windows 7: Go to Control Panel → Appearance and Personalization → Personalization → Screen Saver Settings → Power options or BIOS SETUP on the PC.
- Windows 8(Windows 8.1): Go to Settings → Control Panel → Appearance and Personalization → Personalize → Screen Saver Settings → Power options or BIOS SETUP on the PC.
- Windows 10: Go to Settings → Personalization → Lock screen → Screen timeout settings → Power & sleep or BIOS SETUP on the PC.

Warning

This content is compiled from multiple sources and is provided for reference purposes only. It may not be complete or fully applicable to all situations. If you are unable to resolve your issue, please contact the product manufacturer or an authorized service provider for official support.