

DESCRIPTION

General Description

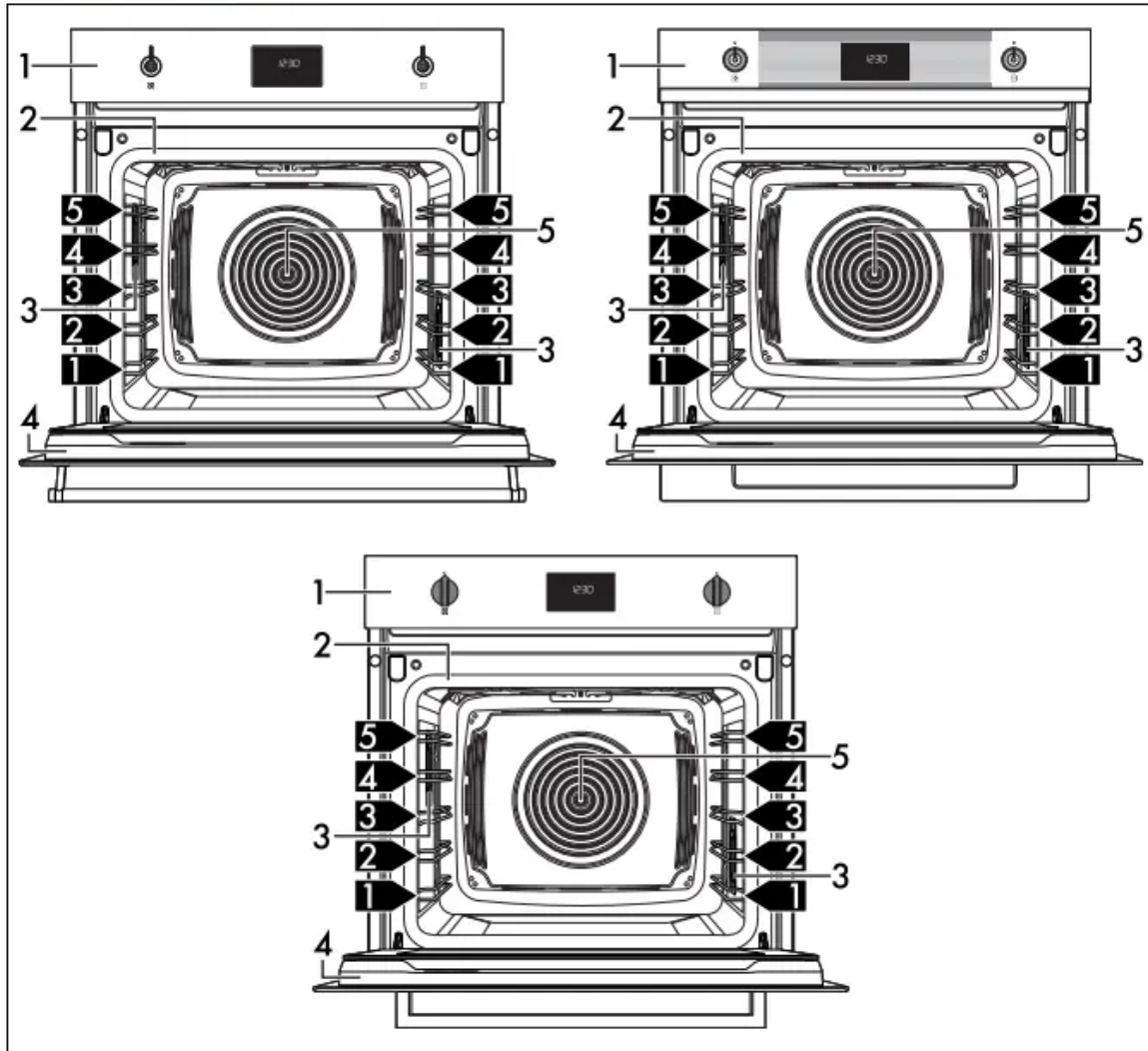

EN

Control panel

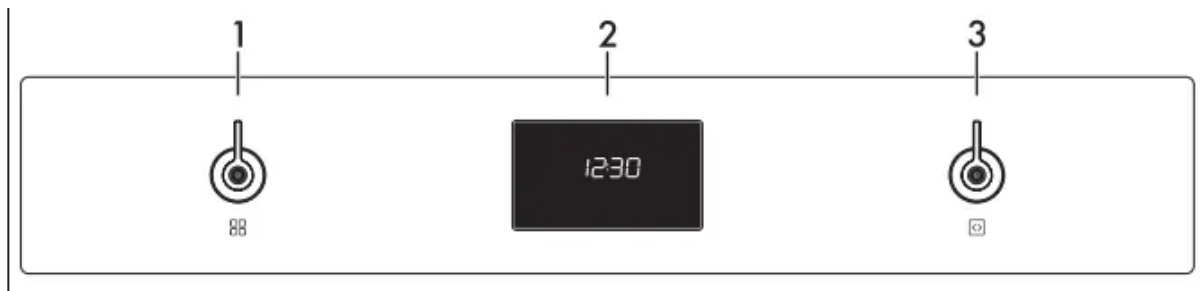

Function knob

- This knob can be used to: turn the appliance on and off; select a function.



Digital programmer

- Displays the current time, the minute minder, the function, the power and the selected cooking temperature and any time set.

Temperature knob

- This knob can be used to set: the cooking temperature; the duration of a function; programmed cooking cycles; the current time.

Shelves

- The appliance features shelves to position trays and racks at different heights. The insertion heights are indicated from the bottom upwards.

Cooling fan

- The fan cools the appliance and comes into operation during cooking.
- The fan causes a steady outflow of air from above the door which may continue for a short period of time even after the appliance has been turned off.

Oven cavity lighting

- The lighting of the oven cavity is activated when any cooking function is selected, excluding the function.

Accessories

- Not all accessories are available on some models.
- The accessories intended to come into contact with food are made of materials that comply with the provisions of current legislation.
- Original supplied and optional accessories can be requested to Authorised Assistance Centres. Use only original accessories supplied by the manufacturer.\

USE

First heating

1. Set a cooking time of at least one hour (see paragraph "Using the oven").
2. Heat the empty oven compartment at the maximum temperature to burn off any residues left by the manufacturing process. When heating the appliance
 - air the room;
 - don't stay.

Racks and trays

- Racks and trays have to be inserted into the side guides until they come to a complete stop.
- The mechanical safety locks that prevent the rack from being removed accidentally must face downwards and towards the back of

the oven cavity.

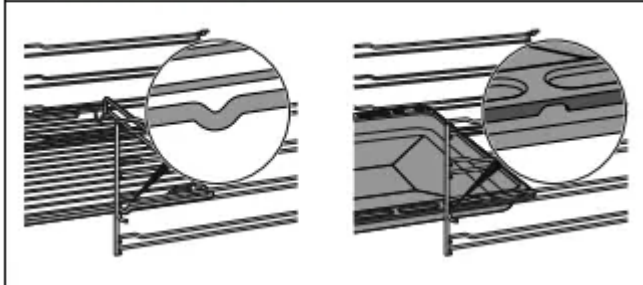

Digital programmer



- The parameters and values for the currently selected function will be indicated on the display.
- To use it, just turn the function and temperature knobs to select the indicated values.
Clock indicator light
Minute minder indicator light
- Cooking indicator light
Programmed cooking indicator light
Door lock indicator light (pyrolytic models only)
Control lock indicator light

Preheating stage

- Cooking itself is preceded by a preheating stage, which allows the appliance to heat to the cooking temperature more quickly.
- The indicator light flashes to indicate that this stage is in progress.
- At the end of preheating the indicator light will stay on permanently, the symbol of the oven cavity flashes and a buzzer sounds.

Open the door

- Place the dish with the food to be cooked into the oven cavity.

Close the door.

- If the dish with the food is already inside the oven cavity, press the temperature knob to start cooking.

Timed cooking

- After selecting a cooking function and temperature, press the temperature knob.
- The display shows flashing.
- Within 3 seconds turn the temperature knob to change the temperature
- Press the temperature knob to set the cooking time (from 1 minute to 13 hours) e.g. "25 minutes").
- Wait 3 seconds.
- The indicator light stops flashing, the symbol lights up and timed cooking begins.
- At the end of the cooking time flashes on the display and a buzzer will sound that can be deactivated by opening the door and/or pressing/turning any of the two knobs.

To delete a timed cooking

- Press the temperature knob.
- The indicator light flashes on the display.
- Within 3 seconds, turn the temperature knob counter-clockwise until the cooking time is reset.
- Wait 3 seconds or press the temperature knob to exit the timed cooking func

Programmed cooking

- After selecting a cooking function and temperature, press the temperature knob.

The display shows flashing.

- Within 3 seconds turn the temperature knob to set the cooking time (from 1 minute to 13 hours) (e.g. "25 minutes").

Press the temperature knob.

1. The display shows the suggested flashing time for immediate cooking.
2. Turn the temperature knob within 3 seconds to set the end of cooking time (e.g. "13:15").
3. Wait 3 seconds.
4. The indicator light and the appliance waits for the set start time.
5. At the end of the cooking time flashes on the display and a buzzer will sound that can be deactivated by opening the door and/or pressing/turning any of the two knobs.

To delete a programmed cooking

1. Press the temperature knob.
2. The indicator light flashes on the display.
3. Within 3 seconds, turn the temperature knob clockwise or counter-clockwise to set a new timed cooking.

4. The set cooking has now been deleted.
5. Minute minder timer during a cooking process
6. After selecting a cooking function and temperature, press the temperature knob two times.
7. The display shows and the indicator

Minute minder timer during a cooking process

1. After selecting a cooking function and temperature, press the temperature knob two times.
2. The display shows and the indicator

To delete a minute minder timer during cooking

1. During cooking, press the temperature knob twice. The indicator light flashes on the display.
2. Within 3 seconds, turn the temperature knob counter-clockwise until the minute minder value is reset.
3. Wait 3 seconds to exit the minute minder function during cooking.

General advice

- Use a fan assisted function to achieve consistent cooking at several levels.
- It is not possible to shorten cooking times by increasing the temperature (the food could be overcooked on the outside and undercooked on the inside).

Advice for cooking meat

- Cooking times vary according to the thickness and quality of the food and to consumer taste.
- Use a meat thermometer when roasting meat, or simply press on the roast with a spoon. If it is hard, it is ready; If not, it needs another few minutes cooking.

Advice for cooking with the Grill and the Fan with grill

1. Meat can be grilled even when it is put into the cold oven or into the preheated oven if you wish to change the effect of the cooking.
2. When using the fan-assisted with grill function, we recommend that you preheat the oven before grilling.
3. We recommend placing the food at the centre of the rack.
4. With the Grill function, we recommend that you set the temperature to the maximum value to optimise cooking.
5. Advice for cooking desserts/pastries and biscuits
6. Use dark metal moulds: They help to absorb the heat better.

7. The temperature and the cooking time depend on the quality and consistency of the dough.
8. To check whether the dessert is cooked right through: At the end of the cooking time, put a toothpick into the highest point of the dessert. If the dough does not stick to the toothpick, the dessert is cooked.
9. If the dessert collapses when it comes out of the oven, on the next occasion reduce the set temperature by about 10°C, selecting a longer cooking time if necessary.

Advice for defrosting and proving

- Place frozen foods without their packaging in a lidless container on the first shelf of the oven.
- Avoid overlapping the food.
- To defrost meat, use the rack placed on the second level and a tray on the first level. In this way, the liquid from the defrosting food drains away from the food.
- The most delicate parts can be covered with aluminium foil.
- For successful proving, a container of water should be placed in the bottom of the oven.

To save energy

1. Stop cooking a few minutes before the time normally used. Cooking will continue for the remaining minutes with the heat which has accumulated inside the oven.
2. Reduce any opening of the door to a minimum to avoid heat dispersal.
3. Keep the inside of the appliance clean at all times.

CLEANING AND MAINTENANCE

Cleaning the surfaces

- To keep the surfaces in good condition, they should be cleaned regularly after use. Let them cool first.

Ordinary daily cleaning

- Always and only use specific products that do not contain abrasives or chlorine-based acids.
- Pour the product onto a damp cloth and wipe the surface, rinse thoroughly and dry with a soft cloth or a microfibre cloth.

Food stains or residues

- Do not use steel sponges and sharp scrapers as they will damage the surface.
- Use normal, non-abrasive products and a wooden or plastic tool, if necessary. Rinse thoroughly and dry with a soft cloth or a microfibre cloth.

- Do not allow residues of sugary foods (such as jam) to set inside the oven. If left to set for too long, they might damage the enamel lining of the oven.

Cleaning the door

- Door disassembly
- For easier cleaning it is recommended to remove the door and place it on a tea towel.

To remove the door proceed as follows:

1. Open the door completely and insert two pins into the holes on the hinges indicated in the figure.
2. Grasp the door on both sides with both hands, lift it forming an angle of around 30° and remove it.
3. To reassemble the door, put the hinges in the relevant slots in the oven, making sure that grooved sections A are resting completely in the slots.

Cleaning the door glazing

- The glass in the door should always be kept thoroughly clean. Use absorbent kitchen roll. In case of stubborn dirt, wash with a damp sponge and an ordinary detergent.
- Removing the internal glass panes
- For easier cleaning the internal glass panes of the door can be removed.
- Lock the door with the appropriate pins.
- Remove the internal glass pane by pulling the rear part gently upwards, following the movement indicated by the arrows 1.
- Release the front pins following the movement indicated by the arrows 2
- Then remove the inner glass pane from the front profile.
- Pull the intermediate glass unit downwards from the door and then lift it upwards.

Drying

Cooking food generates moisture inside the appliance. This is a normal phenomenon and does not affect the appliance's operation in any way. Each time you finish cooking:

1. Let the appliance cool down.
2. Remove any dirt from inside the appliance.
3. Dry the interior of the appliance with a soft cloth.
4. Leave the door open until the inside of the appliance has dried completely.

Cleaning the oven cavity

- In order to keep your oven in the best possible condition, clean it regularly after letting it cool down.

- Avoid letting food residue dry inside the oven cavity, as this could damage the enamel. Take out all removable parts before cleaning. For easier cleaning, it is recommended to remove:

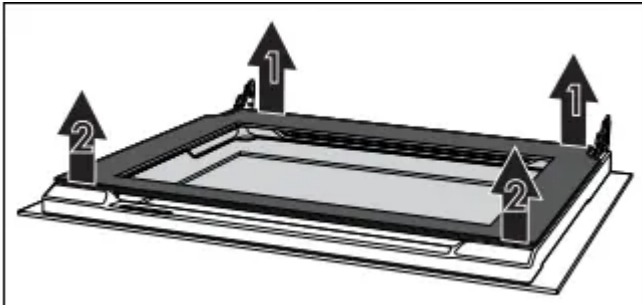

Special cleaning functions

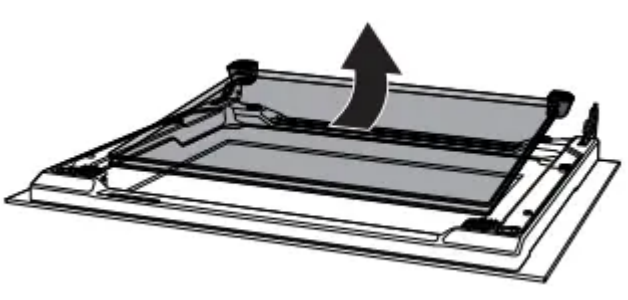

1. Turn the function knob until the following text appears on the display.
2. Press the temperature knob to access the special functions menu.

Preliminary operations

- Before starting the Vapor Clean cycle:
- Completely remove all accessories from inside the oven.
- Remove the temperature probe, if present.
- Remove the self-cleaning panels, if present.
- Pour approx. 120 cc of water onto the floor of the oven. Make sure it does not overflow out of the cavity.
- Spray a water and washing up liquid solution inside the oven using a spray nozzle. Direct the spray towards the side walls, upwards, downwards and towards the deflector.

Close the door.

- During the assisted cleaning cycle, wash the self-cleaning panels (where fitted), which were previously removed, separately in warm water and a small amount of detergent.

Vapor Clean cycle setting

- After having accessed the special functions menu, turn the temperature knob to select the Vapor Clean function.
- Press the temperature knob to confirm the function.

- Wait 3 seconds before starting the function.
- At the end of the Vapor Clean cycle, appears on the display and a buzzer will sound that can be deactivated

Programmed Vapor Clean cycle

- It is possible to program the Vapor Clean function start time, like all other cooking functions.
- After having selected the Vapor Clean function, turn the temperature knob (the indicator light comes on) to set the time at which you want the Vapor Clean function to end.
- Wait 3 seconds before confirming the settings.
- The appliance waits until the set start time to start the Vapor Clean function.

Vapor Clean End

- Turn the function knob to 0 to exit from the function.
- Open the door and wipe away the less stubborn dirt with a microfibre cloth.
- Use a non-scratch sponge with brass filaments on hard to remove deposits.
- In case of grease residues use specific oven cleaning products.
- Remove the residual water inside the oven.
- Replace the self-cleaning panels and the rack/tray support frames, if fitted.
- For greater hygiene and to avoid foods taking on unpleasant odours:
- We recommend drying the inside of the oven with a fan assisted function at 160°C for around 10 minutes.
- If self-cleaning panels are fitted, we recommend that you dry the inside of the oven with a simultaneous catalytic cycle.

Pyrolytic (on some models only)

- Preliminary operations
- Before starting the pyrolytic cycle:
- Clean the internal glass pane following the usual cleaning instructions.
- Remove any food residues or large spills from previous cooking operations from the inside of the oven.
- Completely remove all accessories from inside the oven.
- For very stubborn encrustations spray an oven cleaning product onto the glass (read the warnings on the product); leave for 60 minutes, then rinse and dry the glass using kitchen roll or a microfibre cloth.
- If present, remove the temperature probe.
- Remove the rack/tray support frames.

Pyrolytic function setting

- After entering the special functions menu, turn the temperature knob until the Pyrolytic function is selected.
- Setting of a programmed Pyrolytic cycle
- It is possible to program the Pyrolytic cycle start time like all other cooking functions.
- After selecting the Pyrolysis function, turn the temperature knob (the indicator light lights up) to set the time at which you want the Pyrolysis function to end.
- Wait 3 seconds to confirm the data entered.
- The appliance waits until the set start time to start the Pyrolytic function.

Recommended pyrolytic cycle duration:

1. Little dirt: L01 - 2:00
2. Moderately dirty: L02 - 2:30
3. Very dirty: L03 - 3:00
4. It is not possible to select any function once the door lock device has been activated.
5. The door is locked until the temperature inside the oven cavity returns to a safe level.
6. During the Pyrolytic cycle the fans produce a more intense level of noise due to a greater rotation speed. This is an absolutely normal operation, intended to provide more effective heat dispersal.
7. At the end of the pyrolytic cycle, the fans will continue to operate for long enough to avoid overheating the walls of adjacent units and the front of the oven.
8. It is not possible to select any function once the door lock device has been activated. It is always possible to switch the appliance off, by turning the function knob to the 0 position.

INSTALLATION

General information

- Check the mains characteristics against the data indicated on the plate.
- The identification plate bearing the technical data, serial number and brand name is visibly positioned on the appliance. Do not remove this plate for any reason.
- The appliance must be connected to ground using a wire that is at least 20 mm longer than the other wires. The appliance can work in the following modes:

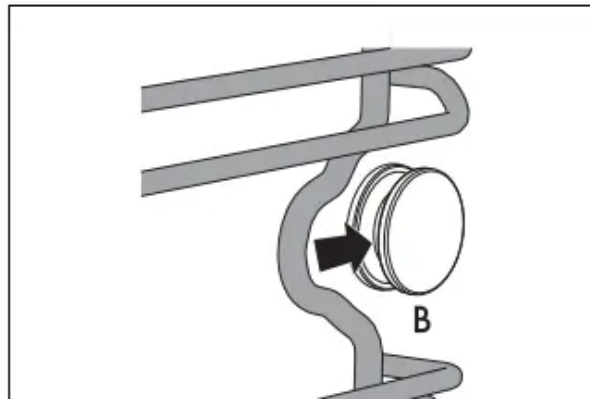
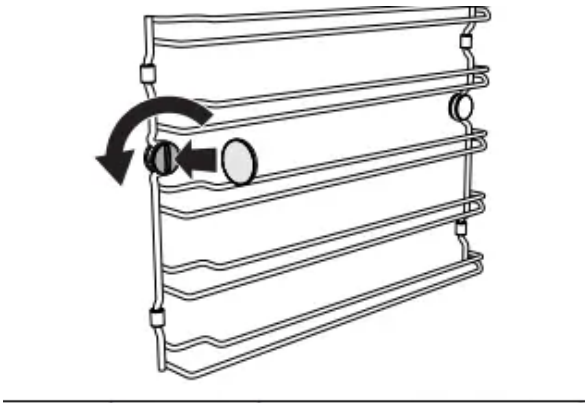

Fixed connection

- Fit the power line with an all-pole circuit breaker with a contact separation distance sufficient to provide complete disconnection in category III overvoltage conditions, pursuant to installation regulations.
- For the Australian/New Zealand market:
- The circuit breaker incorporated in the fixed connection must comply with AS/NZS 3000.
- Connection with plug and socket
- Make sure that the plug and socket are of the same type.
- Avoid using adapters, gang sockets or shunts as these co

Position of the power cable



- Front panel seal
- Glue the supplied seal to the rear part of the front panel to avoid water or other liquids from leaking in.
- Fastening bushings
- Remove the bushing covers on the front of the appliance.
- Mount the appliance into the recess.
- Secure the appliance to the cabinet using screws.
- Cover the bushings with the previously removed covers.

Mounting under worktops (mm) (pyrolytic models only)

- 220-240 V[~]

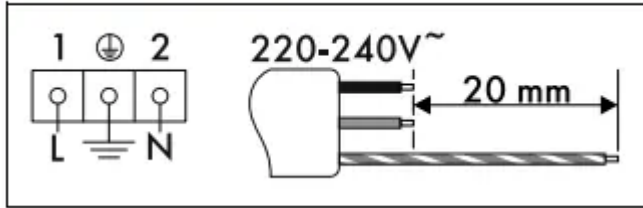

- Whenever a hob is installed above the oven, a wooden separator has to be installed at a minimum distance of 20 mm from the top of the oven to prevent overheating when the two appliances are used at the same time. It must only be possible to remove the separator by using suitable tools.

Warning

This content is compiled from multiple sources and is provided for reference purposes only. It may not be complete or fully applicable to all situations. If you are unable to resolve your issue, please contact the product manufacturer or an authorized service provider for official support.