

Setting up your new microwave oven

Be sure to follow these instructions closely so that your new microwave oven works properly.

Checking the parts

Carefully unpack your microwave oven, and make sure you've received all the parts shown below. If your microwave oven was damaged during shipping, or if you do not have all the parts, contact the Samsung Call Center.

(Refer to the WARRANTY AND SERVICE INFORMATION on page 38.)

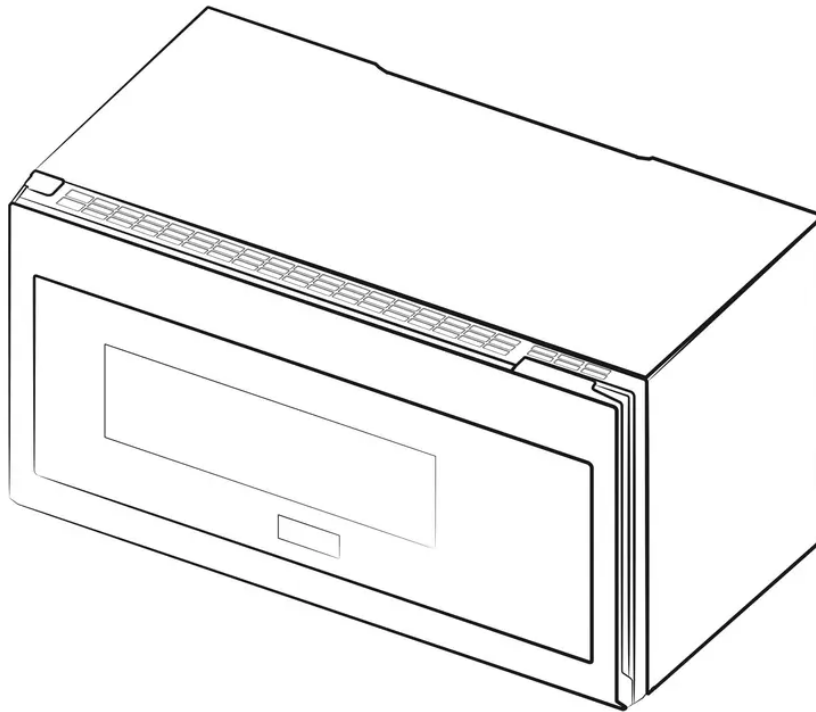

Microwave oven

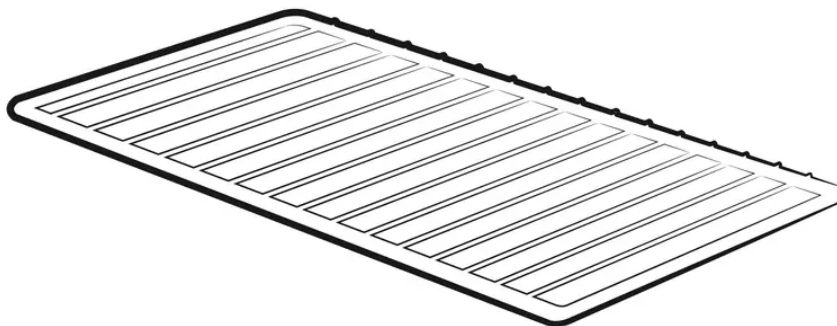

*** Shelf**

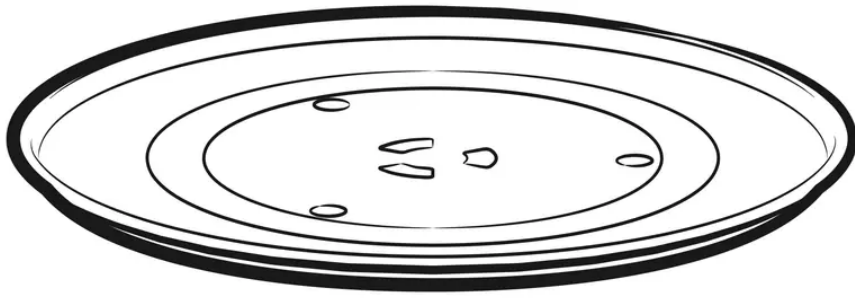

*** Glass tray**

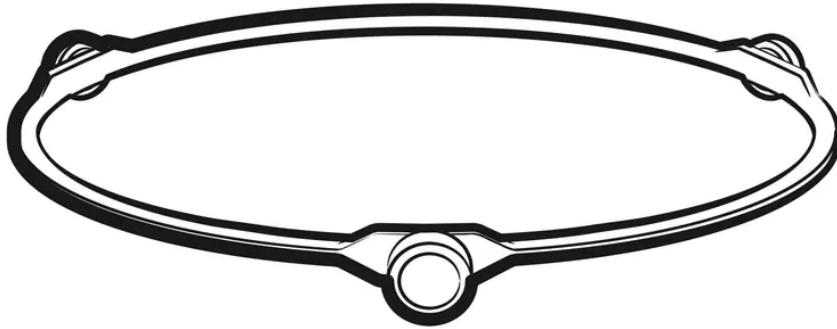

*** Roller guide ring**

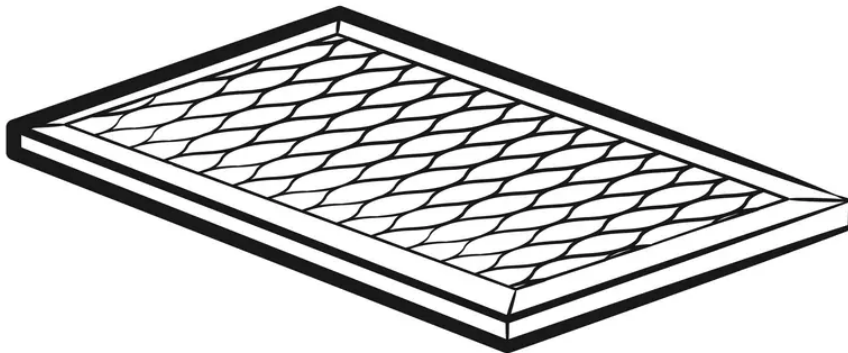

*** Charcoal filter**

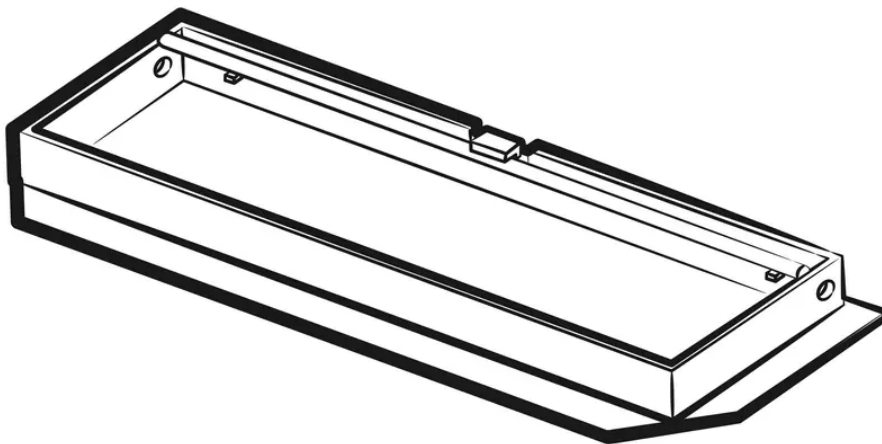

*** Exhaust adaptor**

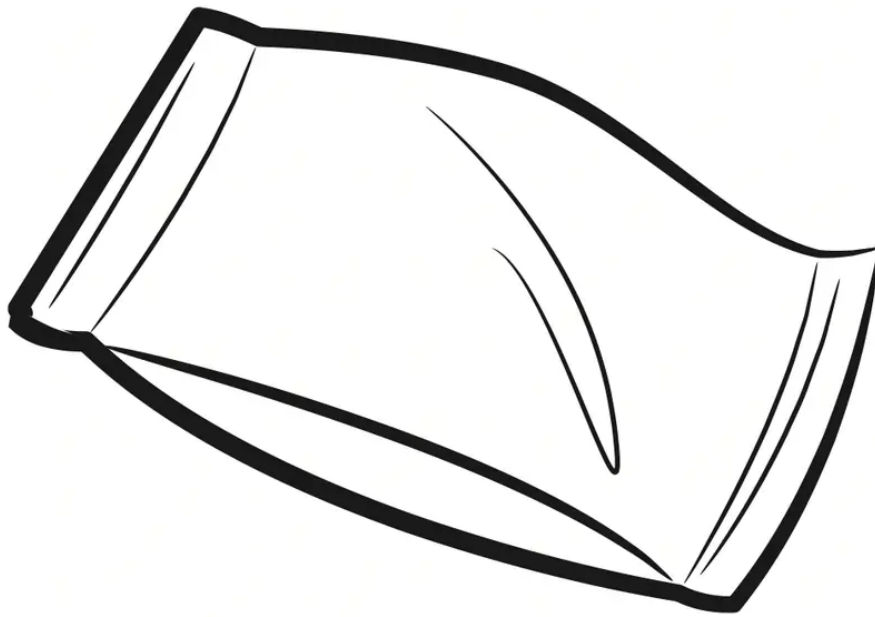

*** Hardware kit (Screws & Brackets)**

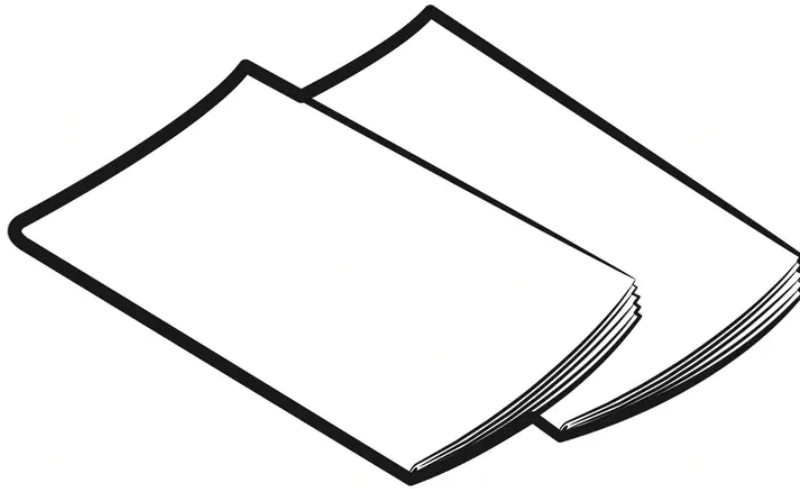

Manuals (User & Installation)

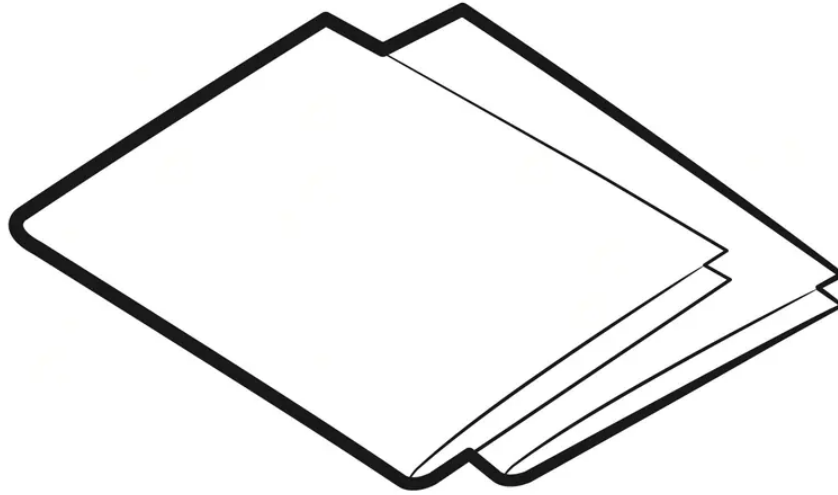

Templates (Top & Wall)

Setting up your microwave oven

1. Open the door by pulling the handle on the right side of the door.
2. Wipe the inside of your microwave oven with a damp cloth.

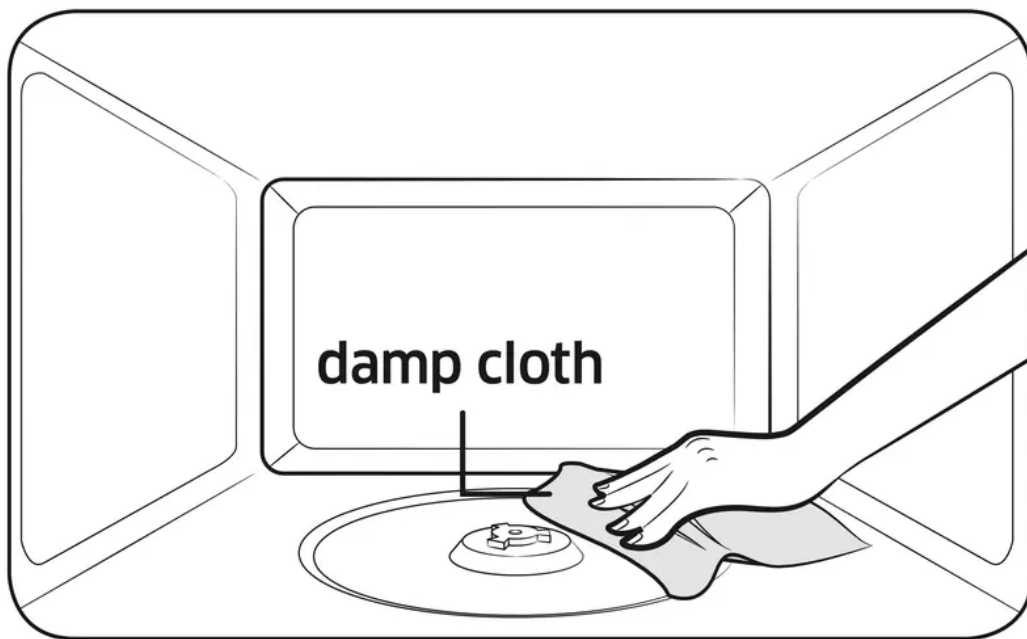

3. Install the pre-assembled ring into the indentation at the center of the microwave oven.

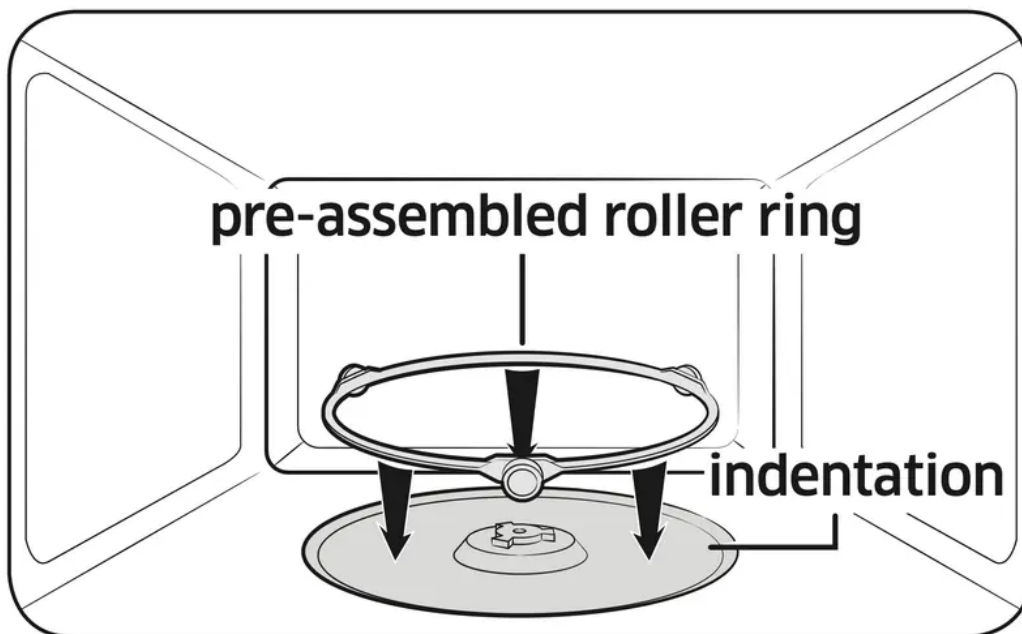

4. Place the glass tray securely in the center of the pre-assembled roller ring.

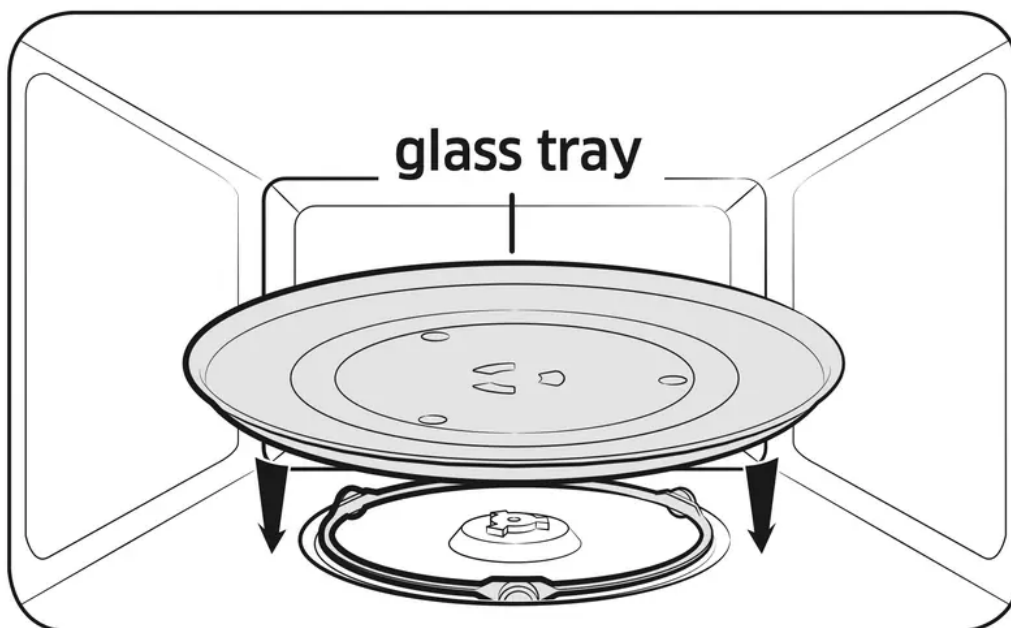

Learning about the control panel

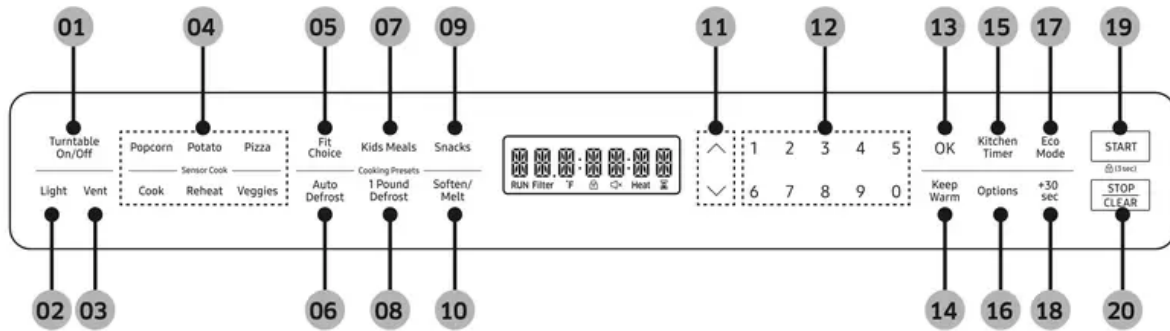

1. Turntable On/Off Button
2. Light Button (Hi/Low/Off)
3. Vent Button (4 Speed & On/Off) S
4. Sensor Cooking Buttons
5. Fit Choice Button
6. Auto Defrost Button
7. Kids Meals Button
8. 1 Pound Defrost Button
9. Snacks Button
10. Soften/Melt Button
11. Up & Down (More and Less) Buttons
12. Numeric Buttons
13. OK Button
14. Keep Warm Button
15. Kitchen Timer Button
16. Options Button
17. Eco Mode Button
18. +30 sec Button
19. START Button
20. STOP/CLEAR Button

Setting the time

Your microwave oven is equipped with a built-in clock. Set the clock when first installing your microwave oven and after a power failure. The time is displayed whenever the microwave oven is not being used.

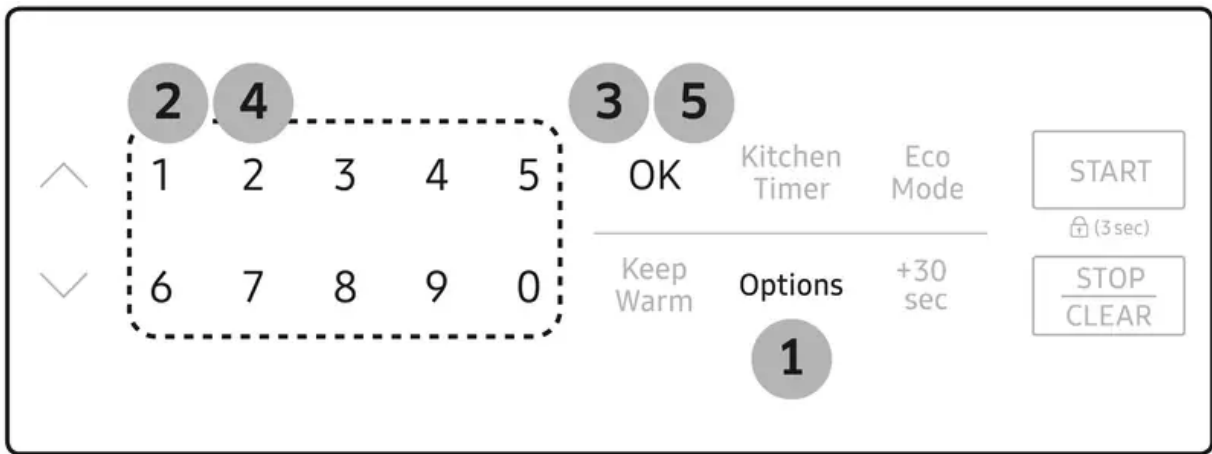

1. Press the Options button.
2. Press the 9 button.
3. Press the OK button.
4. Use the numeric buttons to enter the current time. You need to press at least three numbers to set the clock. For example, if the current time is 5:00, press 5, 0, 0. The display will show 5 : 00.
5. Press the OK button.

Using my setting feature

You can customize your new microwave oven to suit your preferences.

To customize:

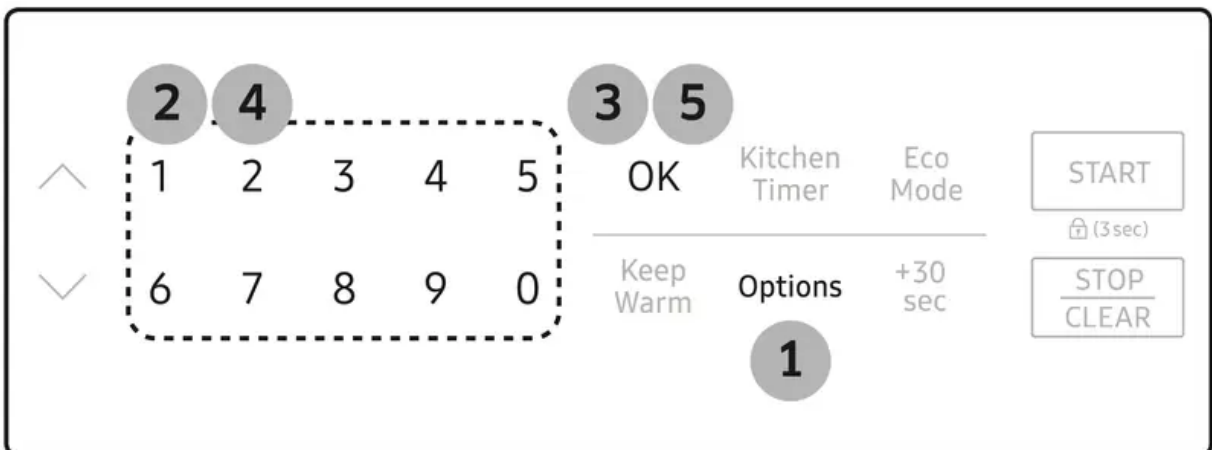

1. Press the Options button.
2. Press one of the numeric buttons to select a function you want to customize.
3. Press the OK button.
4. Press one of the numeric buttons to select a setting.
5. Press the OK button.

The functions, options, and corresponding numeric buttons are listed in the table below.

No.	Function	Description	Options
1	Display Weight	Weight options are pounds and kilograms.	1 Lbs. 2 Kg.
2	12 HR/24 HR	The clock can display in either the 12 HR or 24 HR time mode.	1 12 HR 2 24 HR
3	Sound	Sound can be turned On and Off.	1 Sound ON 2 Sound OFF
4	Remind End Signal	The Remind End Signal can be turned On and Off.	1 ON 2 OFF
5	Daylight Savings Time Adjustment	The time can be advanced one hour for DST without resetting the clock.	1 ON (to advance one hour) 2 OFF (to go back one hour)
6	Demo Mode	The Demo Mode can be turned On and Off.	1 ON 2 OFF
7	Filter Remind	The Filter Remind function can be turned On and Off.	1 ON 2 OFF
8	Word Scroll Speed	There are three speeds, Slow, Normal, and Fast. The default is Normal speed.	1 Slow speed 2 Normal speed 3 Fast speed
9	Clock	The clock can be adjusted.	Press the numeric buttons to enter the current time. (First 2 digits are for hours, last 2 digits are for minutes.)

NOTE: If you change your mind while adjusting a setting, press the STOP/CLEAR button to cancel, and then adjust the setting again.

NOTE: If there is a power interruption, you will need to reset these options.

NOTE: If the clock is set for standard time, the Daylight Savings Time Adjustment function allows you to change the time easily without needing to reset the clock. Daylight Saving Time begins for most of the United States at 2 a.m. on the first Sunday of April and reverts to Standard time at 2 a.m. on the last Sunday of October.

Filter Reminder

If the Filter Remind function is ON, the microwave will remind you to clean or replace the grease filter every four months. When it is time to clean or replace the grease filter, the microwave displays the "Filter" message to remind you to clean or replace the grease filter. To remove the

message, press the number 0 when the microwave is in standby mode. If you don't want to receive this message, set the Filter Remind function off in Options.

Using your microwave oven

Using the stop/clear button

The STOP/CLEAR button allows you to clear instructions you have entered.

It also allows you to pause your microwave oven's cooking cycle, so that you can check the food.

- To pause the oven during cooking, press the STOP/CLEAR button once. To restart, press the START button.
- To stop cooking, erase instructions, and return the oven display to the time of day, press the STOP/CLEAR button twice.
- To clear instructions you have just entered, press the STOP/CLEAR button once, and then re-enter the instructions.
- To cancel a timer setting, press the STOP/CLEAR button once.

Using the child lock

The Child Lock function allows you to lock all buttons except Eco Mode so that the microwave oven cannot be operated by children accidentally. The oven can be locked at any time.

Activating / Deactivating

If you want to activate or deactivate the child lock function, press the START button for 3 seconds. The display will show 'CHILD LOCK ON' or 'CHILD LOCK OFF' when the oven is locked or unlocked, and then redisplay the time.

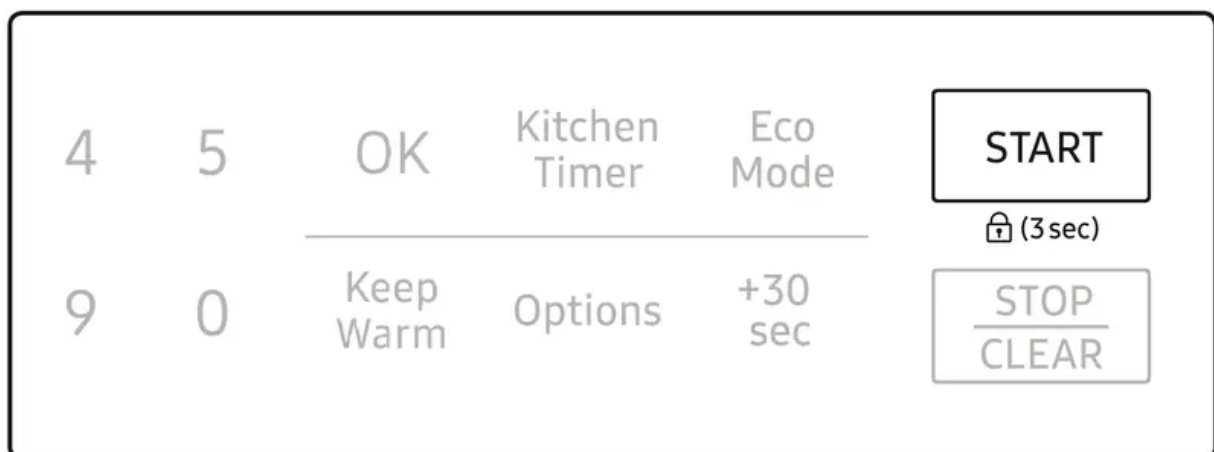

Using the kitchen timer

Your microwave has a built-in timer function - the Kitchen Timer. Use the Kitchen Timer for timing up to 99 minutes, 99 seconds.

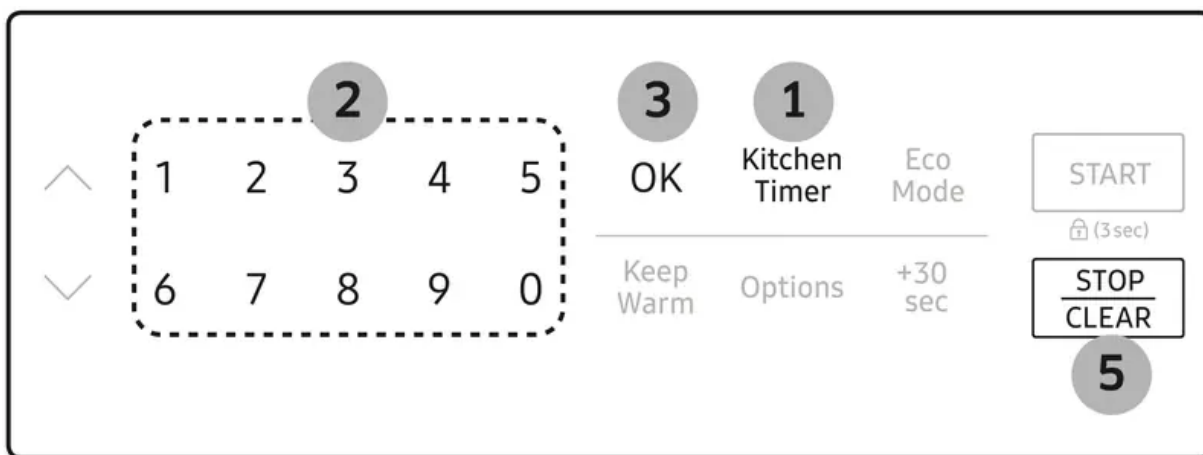

1. Press the Kitchen Timer button.
2. Use the numeric buttons to set the time you want the timer to run. (Max time 99 minutes, 99 seconds.)
3. Press the OK button.
4. The display counts down, and then beeps when the time has elapsed.
5. To cancel the timer setting : Press the STOP/CLEAR button once.

Using the microwave +30 sec. feature

This feature offers a convenient way to heat food in set time increments at the High power level (100 % power).

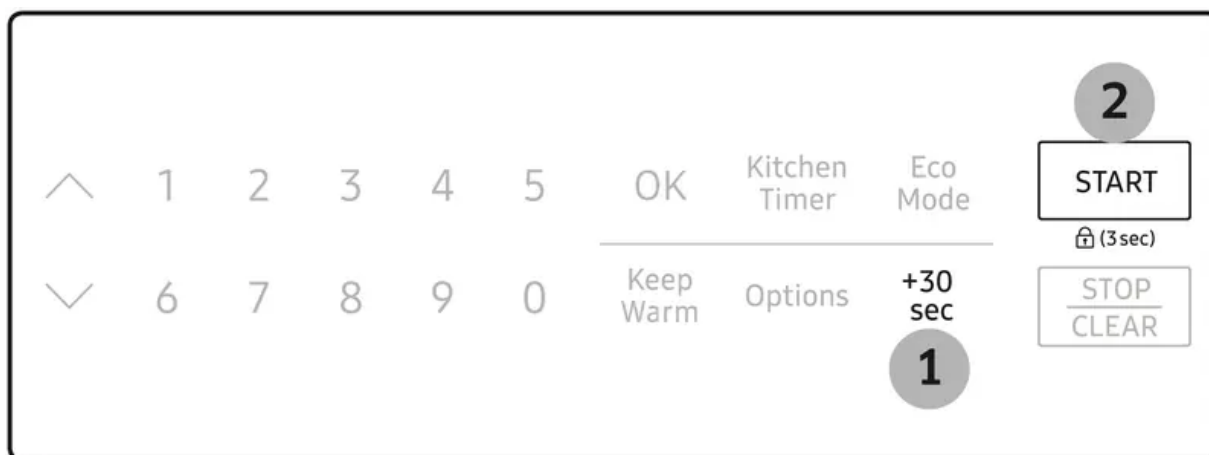

1. Press the +30 sec button for each additional 30 seconds you want the food to be cooked for. (For example, press the button twice to cook for one minute.)
2. Press the START button.





NOTE: When the oven is operating, if you press the +30 sec button, the cooking time will be increased by 30 seconds.

Using the more/less feature

The More or Less feature allows you to adjust the pre-set cooking time. It works with 1 and 2 stage cooking, regular microwave cooking, and Keep Warm.



Use the More or Less feature only after cooking has begun.

1. To ADD more time to a cooking procedure, press the More button (). Each time you press the More button (), the cooking time will be increased by 10 seconds.
2. To REDUCE the time of a cooking procedure, press the Less button (). Each time you press the Less button (), the cooking time will be decreased by 10 seconds.

Using the eco mode

Eco Mode reduces standby power usage. When you press the Eco Mode button once, the display will go out and the microwave shifts to a mode which minimizes power usage. To cancel the Eco Mode, press the Eco Mode button once again, or press any other button.

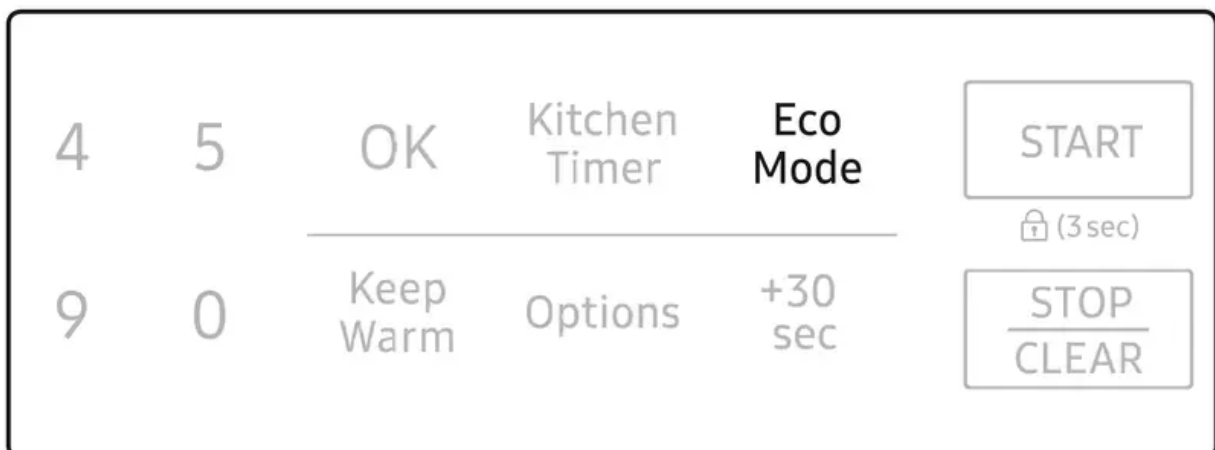

Turntable on/off feature

For best cooking results, leave the turntable on. However, for large dishes it can be turned off.

Press the Turntable On/Off button to turn the turntable on or off.

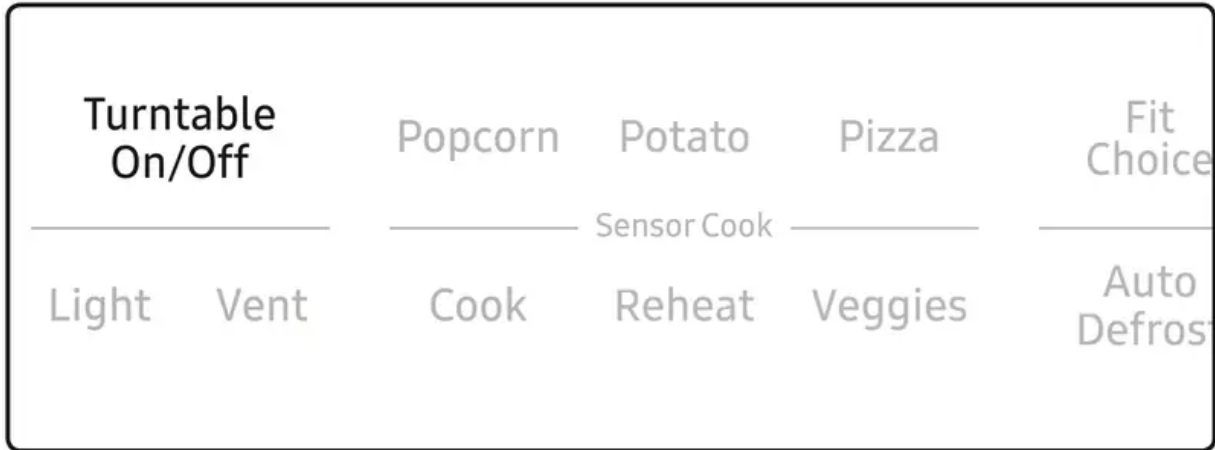

NOTE

You can use this feature in the following modes: Microwave and Keep Warm
If the turntable does not rotate for an extended period of time, food may burn.

CAUTION

The turntable may become too hot to touch.
Use pot holders to handle the turntable during and after cooking.

Turning on the light

Press the Light button to turn the cooktop lamp on or off. Press the button once for high, twice for low, and three times to turn the cooktop lamp off.

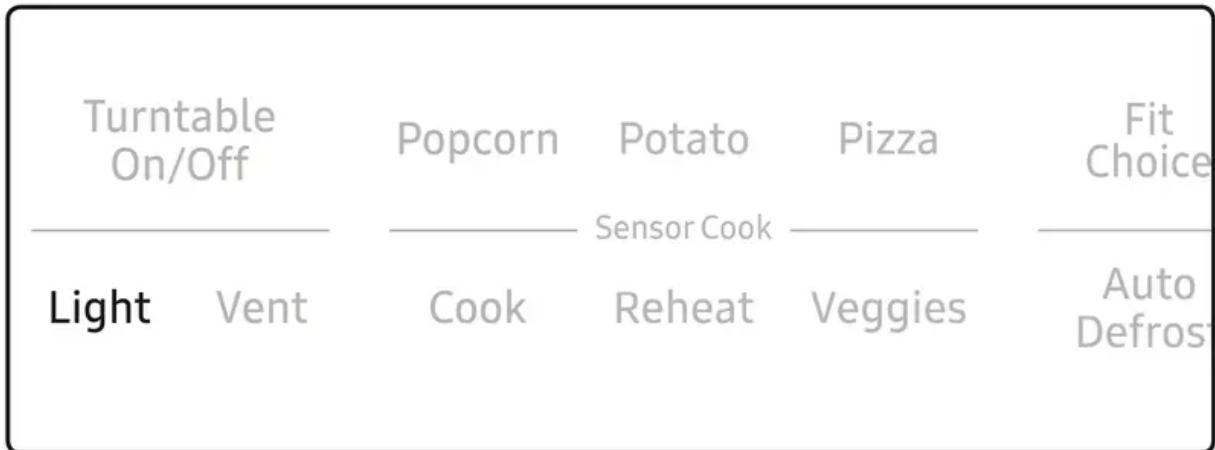

Turning on the vent

The vent fan removes steam and other vapors that result from cooking on the rangetop below.



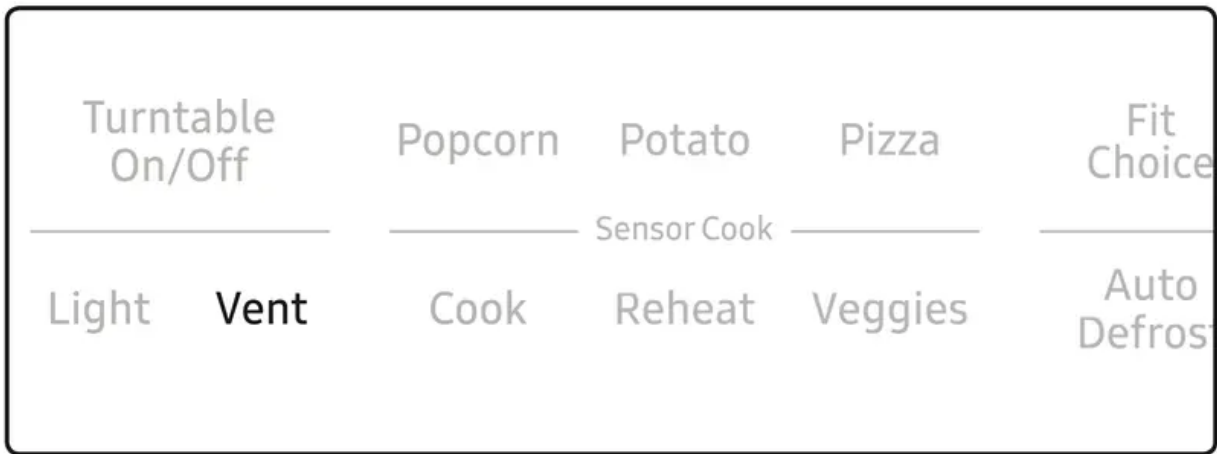

Press the Vent button once for boost fan speed, twice for high fan speed, three times for medium fan speed, and four times for low fan speed. Press the Vent button 5 times to turn the fan off.

NOTE: The exhaust fan's speed will decrease when the oven's cooking function is activated.

NOTE:

The Vent Fan protects the microwave from excess heat.

It automatically turns on if it senses too much heat. If you have turned the fan on, you may find that you cannot turn it off. The fan will automatically turn off when the internal parts are cool. It may stay on for 30 minutes or more after the cooktop and microwave controls are turned off.

Using the keep warm feature

You can keep cooked food warm in your microwave oven for up to 99 minutes and 99 seconds.

1. Press the Keep Warm button.

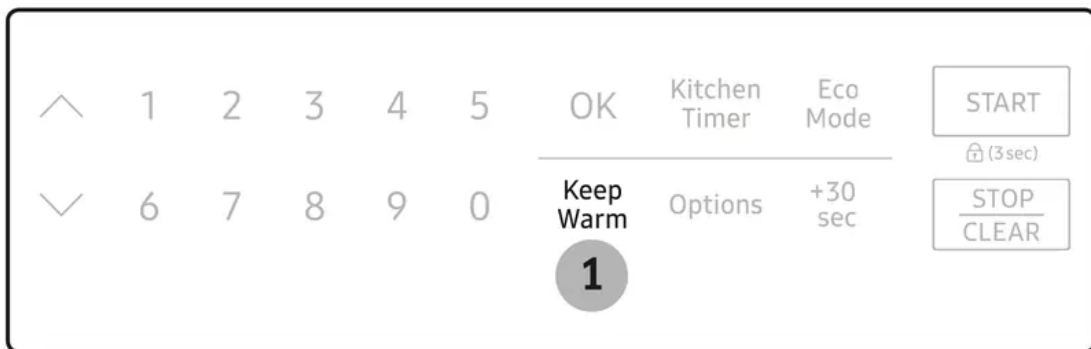

2. Enter the warm hold time by pressing the numeric buttons. If you don't set the time, your oven will maintain the Warm Hold function for 99 minutes.



3. Press the START button.

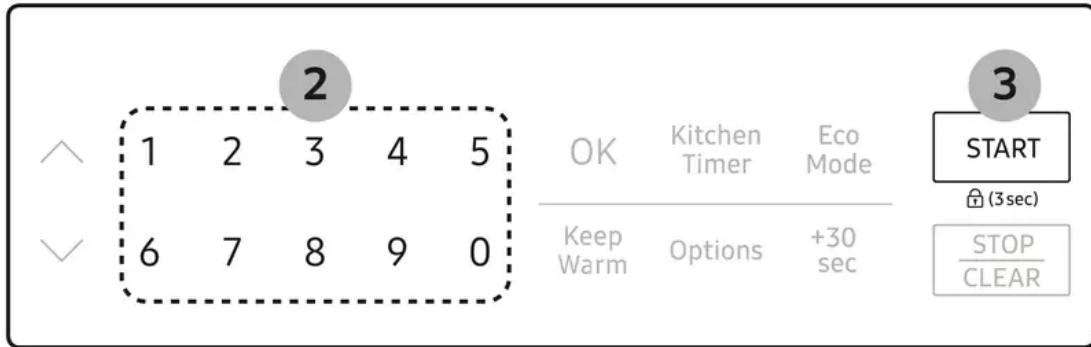

NOTE

- Keep Warm operates for up to 99 minutes and 99 seconds.
- The Vent Fan protects the microwave from excess heat. It automatically turns on if it senses the overheating. If you have turned the fan on, you may find that you cannot turn it off. The fan will automatically turn off when the internal parts are cool.

NOTE

- Food that is cooked covered should also be covered during Keep Warm.
- Pastry items (pies, turnovers, etc.) should be uncovered during Keep Warm.
- Complete meals kept warm on a dinner plate can be covered during Keep Warm.

Below are the amounts of food we recommend you apply the Keep Warm function to by Food Type.

Food Type	Recommended Quantity
Liquid	1-2 cups
Dry	5-10 oz.

Using the auto defrost button

To thaw frozen foods, enter the weight of the food, and the microwave automatically sets the defrosting time, power level, and standing time.



Press the START button to start defrosting.

1. Press the Auto Defrost button. The display shows: ENTER WEIGHT.

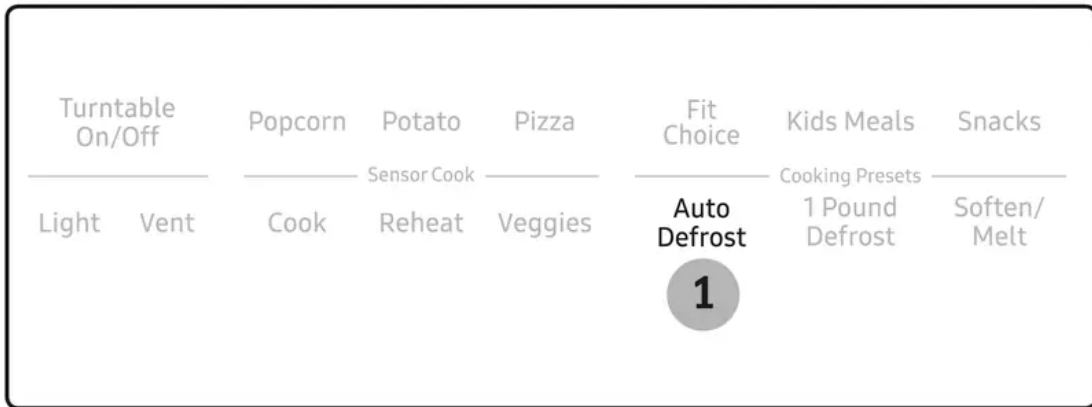

2. Press the numeric buttons to directly enter the weight of the food. (0.1-6.0 lbs. See the table at the beginning of the next page.)
3. Press the START button.

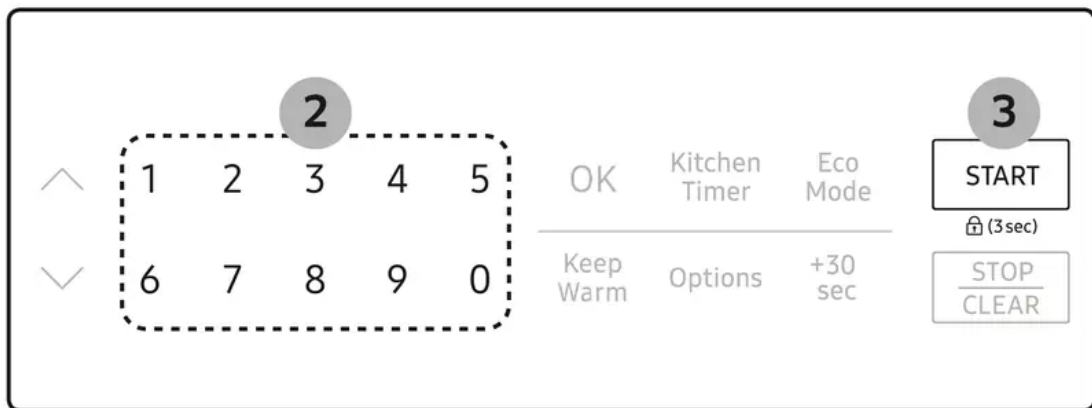

4. The oven will beep and the display will read TURN THE FOOD OVER during the defrosting process. Open the oven door, and turn the food over. If you do not turn the food over when TURN THE FOOD OVER is displayed, the microwave will continue until the end of cooking time.

Follow the instructions below when defrosting different types of food.

Food	Amount	Procedure
Roast Beef, Pork	2.5-6.0 lbs.	Start with the food placed fat side down. After each stage, turn the food over and shield any warm portions with narrow strips of aluminum foil. Let stand, covered for 10-20 minutes.
Steaks, Chops, Fish	0.5-3.0 lbs.	After each stage, rearrange the food. If there are any warm or thawed portions of food, shield them with narrow, flat pieces of aluminum foil. Remove any pieces of food that are nearly defrosted. Let stand, covered for 5-10 minutes.
Ground Meat	0.5-3.0 lbs.	After each stage, remove any pieces of food that are nearly defrosted. Let stand, covered with foil for 5-10 minutes.
Whole Chicken	2.5-6.0 lbs.	Before freezing the poultry, remove the giblets. When you defrost the poultry, start defrosting with the breast side down. After the first stage, turn the chicken over and shield any warm portions with narrow strips of aluminum foil. After the second stage, again shield any warm portions with narrow strips of aluminum foil. Let stand, covered for 30-60 minutes in the refrigerator.
Chicken Pieces	0.5-3.0 lbs.	After each stage, rearrange or remove any pieces of food that are nearly defrosted. Let stand for 10-20 minutes.

NOTE: Check the food when you hear the oven signal. After the final stage, small sections may still be icy; let them stand to continue the thawing process. The food is not defrosted until all ice crystals have melted. Shielding roasts and pieces of steak using small pieces of foil prevents the edges from being cooked before the center of the food has defrosted. Use narrow, flat, smooth strips of aluminum foil to cover edges and thinner sections of the food.

Using the 1 pound defrost button

To thaw 1.0 lbs of frozen food, press this button, and the microwave automatically sets the defrosting time, power level, and standing time.

1. Press the 1 Pound Defrost button. The display shows: 1.0 LB.

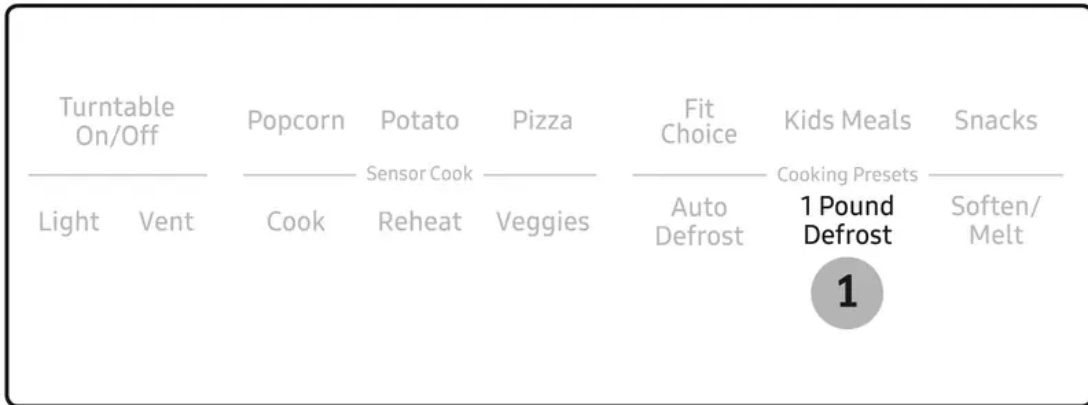

2. Press the START button to start defrosting.
3. The oven will beep and the display will read TURN THE FOOD OVER during the defrosting process. Open the oven door, and turn the food over. Press the START button to resume the defrosting process.
4. If you do not turn the food over when TURN THE FOOD OVER is displayed, press the START button to continue the defrosting process. The microwave will not continue until you press START.

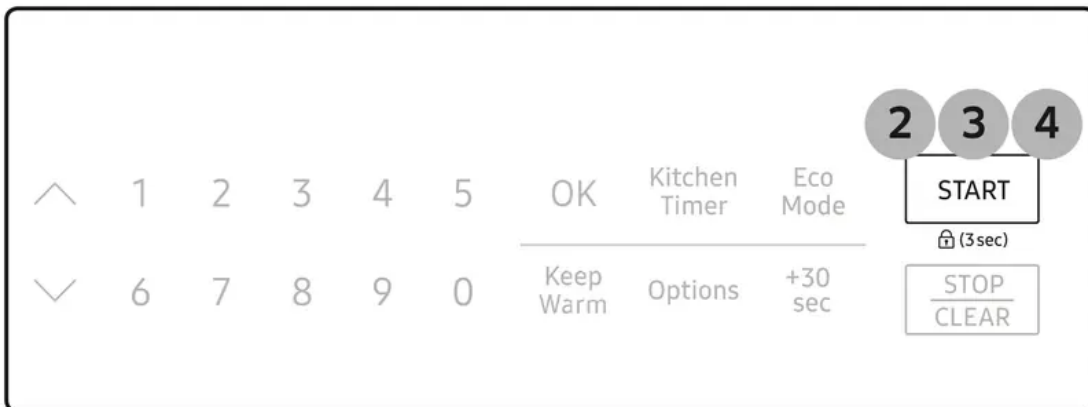

Using the sensor cooking buttons

The Sensor Cooking buttons let you cook favorite foods using preset power levels and times at the touch of a button. If the food is not thoroughly cooked or reheated when you use the auto cook feature, complete the cooking process by selecting a power level and cooking the food for an additional amount of time.

1. Put the food on the tray.

2. Press the category button that corresponds to the food you want to cook.

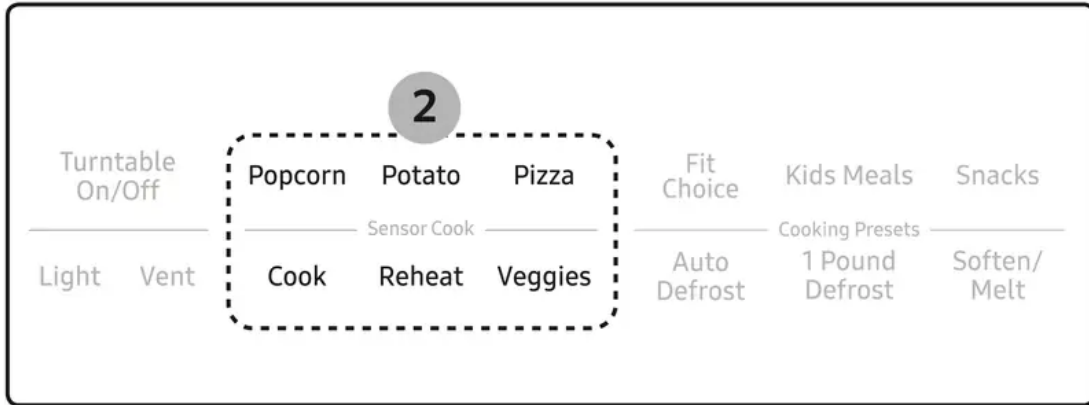

Select the Cook Number designated for that food. To select, press the Up/Down buttons or the appropriate numeric buttons. For example, to reheat a casserole, after selecting Reheat, select

1. See the tables on this page and the following page for details.

Press the START button. The microwave oven will automatically operate for the preprogrammed time.

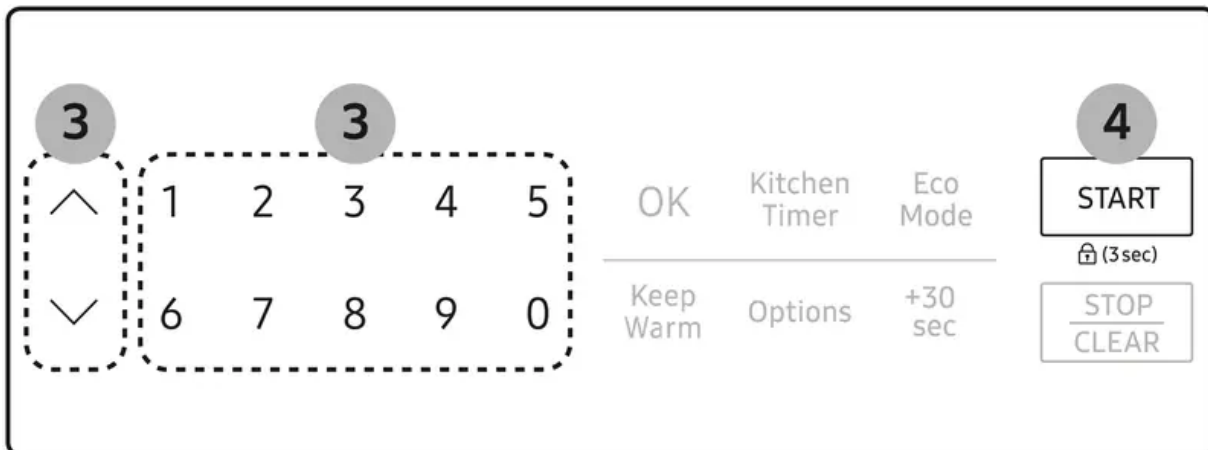

Category	Cook No.	Food	Amount	Directions
Popcorn	1	Popcorn	3.0-3.5 oz. 1 package	Cook only one microwave popcorn bag at a time. Be careful when removing the heated bag from the oven and opening it. Let the microwave oven cool for at least 5 minutes before using it again.
Potato	1	Potato	1-6 potatoes.	Pierce each potato several times with a fork. Place on the turntable in a spoke-like fashion. After cooking, let the potatoes stand for 3-5 minutes. Let the microwave oven cool for at least 5 minutes before using it again.
Pizza	1	Pizza	1-4 slices	Place 1-4 pizza slices on a microwave-safe plate with the wide ends of the slices towards the outside edge of the plate. Do not let the slices overlap. Do not cover. Let the microwave oven cool for at least 5 minutes before using it again.

Category	Cook No.	Food	Amount	Directions
Cook	1	Beverage	8 oz.	Use a measuring cup or mug and do not cover. Place the beverage in the microwave oven. After heating, stir well. Let the oven cool for at least 5 minutes before using it again.
	2	Chicken Breasts	8-24 oz.	Place the chicken breasts on a microwave safe plate and cover with vented plastic wrap. Cook to an internal temperature of 170 °F. Let stand for 5 minutes.
	3	Frozen Breakfast	4-8 oz.	Follow the package instructions for covering and letting stand. Use this button for frozen sandwiches, breakfast entrees, pancakes, waffles, etc. Let the microwave oven cool for at least 5 minutes before using it again.
	4	Frozen Dinner	8-14 oz.	Remove the food from its wrapping and follow the instructions on the box for covering and letting stand. Let the microwave oven cool for at least 5 minutes before using it again.

Category	Cook No.	Food	Amount	Directions
Reheat	1	Casserole	1-4 servings	Cover the plate with a lid or vented plastic wrap. If the food is not as hot as you would like after using the "Sensor Cooking Reheat" function, continue heating using additional time and power. Stir the food once before serving. Contents: Casserole, refrigerated foods.
	2	Dinner plate	1-4 servings	Use only precooked, refrigerated foods. Cover the plate with vented plastic wrap or waxed paper tucked under the plate. If the food is not as hot as you would like after using the "Sensor Cooking Reheat" function, continue heating using additional time and power. Contents: 3-4 oz. meat, poultry or fish (up to 6 oz. with bone) ½ cup starch (potatoes, pasta, rice, etc.) ½ cup vegetables (about 3-4 oz.)
	3	Pasta	1-4 servings	Cover the plate with a lid or vented plastic wrap. If the food is not as hot as you would like after using the "Sensor Cooking Reheat" function, continue heating using additional time and power. Stir the food once before serving. Contents: Pasta: canned spaghetti and ravioli

Category	Cook No.	Food	Amount	Directions
Veggies	1	Fresh Vegetables (Fresh Veggies)	1-4 cups	Place the fresh vegetables in a microwave-safe ceramic, glass, or plastic dish and add 2-4 tbs. of water. Cover with a lid or vented plastic wrap. Stir before letting stand. Let the microwave oven cool for at least 5 minutes before using it again.
	2	Frozen Vegetables (Frozen Veggies)	1-4 servings	Place the frozen vegetables in a microwave-safe ceramic, glass, or plastic dish and add 2-4 tbs. of water. Cover with a lid or vented plastic wrap to cook. Stir before letting stand for 3-5 minutes. Let the microwave oven cool for at least 5 minutes before using it again.

Using the microwave setting cooking times & power levels

Your microwave oven allows you to set two different cooking stages, each with its own time length and power level. The power level lets you control the heating intensity from Warm (1) to High (10).

Power levels

The 10 power levels allow you to choose the optional power level for your cooking needs.

No.	Power Level	Description	No.	Power Level	Description
1	10	Warm	6	60	Simmer
2	20	Low	7	70	Medium high
3	30	Defrost	8	80	Reheat
4	40	Medium low	9	90	Sauté
5	50	Medium	10	100	High

One-stage cooking

For simple one-stage cooking, you only need to set the cooking time. The power level is automatically set to High. If you want to set the power level to any other level, press OK after entering the cooking time, and then use the numeric buttons to set the level.



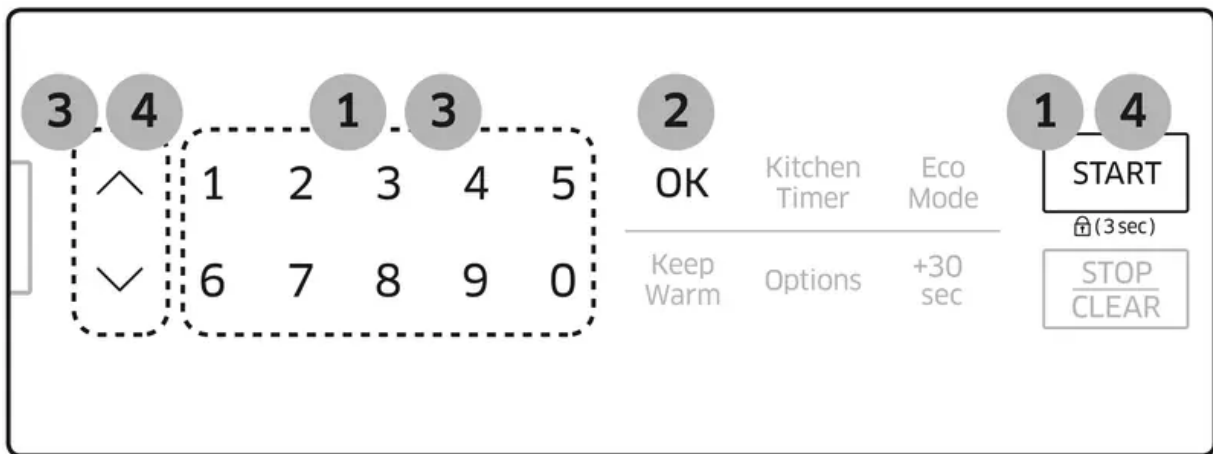

1. Use the numeric buttons to set a cooking time. You can enter a time from one second to 99 minutes and 99 seconds.
To select a time greater than one minute, enter the seconds too. (For example, to set a cooking time of 20 minutes, enter 2, 0, 0, 0.) If you do not need to set the power level, just press the START button. The microwave will automatically operate at the High power level. If you want to change the power level, go to Step 3.
2. If you want to set the power level to a level other than High, press the OK button.
3. Press the Up/Down buttons or numeric buttons that correspond to the power level you want to use.
4. Press the START button. If you want to add to or reduce the cooking time, use the Up/Down buttons. You can adjust the cooking time while the microwave oven is operating.

Multi-stage cooking (maximum of 2 stages)

Your oven allows you to set two different cooking stages, each with its own time length and power level. The power level lets you control the heating intensity from Warm to High.

1. Follow steps 1, 2, and 3 from the “One-stage cooking” section.
2. Press the OK button to move to the second stage.
3. Follow steps 1, 2, 3, and 4 from the “One-stage cooking” section.

Using the fit choice button

1. Press the Fit Choice button.
2. Press the Up/Down buttons or numeric buttons to select the menu/item. (Refer to the Fit Choice table below for a list of the items.)

3. Press the OK button.

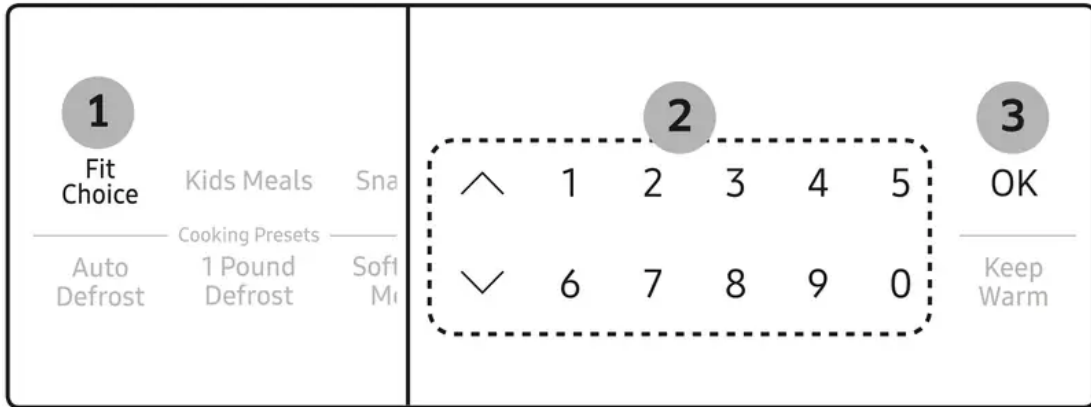

4. Press the Up/Down buttons or numeric buttons to select the amount. (Refer to the Fit Choice table for the serving size.)

5. Press the START button to begin cooking.

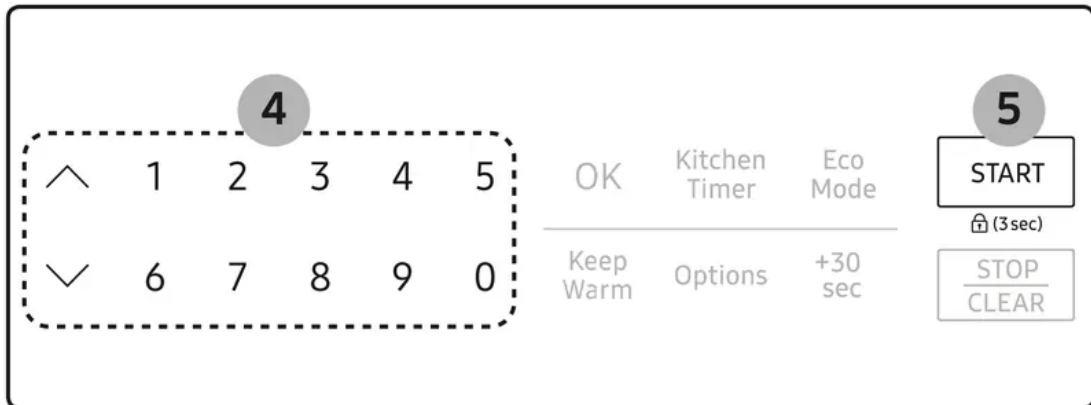

Fit Choice table

Menu / Item		No. / Amount		Instructions
1	Spinach	1	1 serving	Wash and clean the spinach. Place the spinach in a microwave safe bowl. Add 1-4 tablespoons of water (1 Tbsp per serving). Cover during cooking and stir afterwards.
		2	2 servings	
		3	3 servings	
		4	4 servings	
2	Squash	1	1-2 lbs.	Slice the squash in half and remove the seeds. Place the squash cut side down in a microwave safe dish and cover with the plastic wrap. If needed, add a ¼ cup of water.
		2	2-3 lbs.	



Menu / Item		No. / Amount		Instructions
3	Brown rice	1	1 serving	Place 0.5 cups brown rice + 1 cup water for 2 servings or 1 cup brown rice + 2 cups water for 4 servings in a microwave safe bowl. Stir well before and fluff with a fork afterwards. Let stand 5 minutes before serving.
		2	2 servings	
4	Oatmeal	1	1 package	Follow the package directions for the recommended amount of water needed. Stir well before and afterwards.
		2	2 packages	
5	Quinoa	1	1 serving	Follow the package directions for the recommended amount of water needed. When the microwave beeps, stir well, and then restart the microwave.
		2	2 servings	
6	Bone in chicken pieces	1	2 servings	Brush the chicken pieces with oil and seasonings. Arrange chicken pieces in dish with meatiest portions toward the outside edge of dish, and then cover with wax paper. Place the dish on the center of the turntable.
		2	4 servings	
7	Fresh fish fillet	1	1 serving	Put the fillets (cod, pollack, etc.) in a dish, and then cover with plastic wrap. Place the dish on the center of the turntable.
		2	2 servings	
8	Fresh salmon fillet	1	1 serving	Put the salmon fillets in a dish, and then cover with plastic wrap. Place the dish on the center of the turntable.
		2	2 servings	
9	Fresh prawns	1	2 servings	Put the prawns in a dish, and then cover with plastic wrap. Place the dish on the center of the turntable.
		2	4 servings	

Using the kids meals button

1. Press the Kids Meals button.
2. Press the Up/Down buttons or numeric 3 buttons to select the item. (Refer to the Kids Meals table below for a list of the items.)

3. Press the OK button.

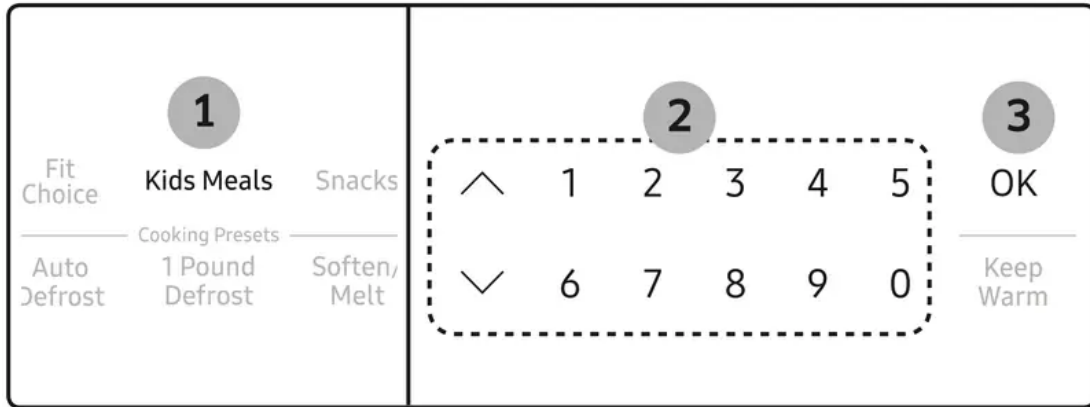

4. Press the Up/Down buttons or numeric buttons to select the amount. (Refer to the Kids Meals table for the serving size.)

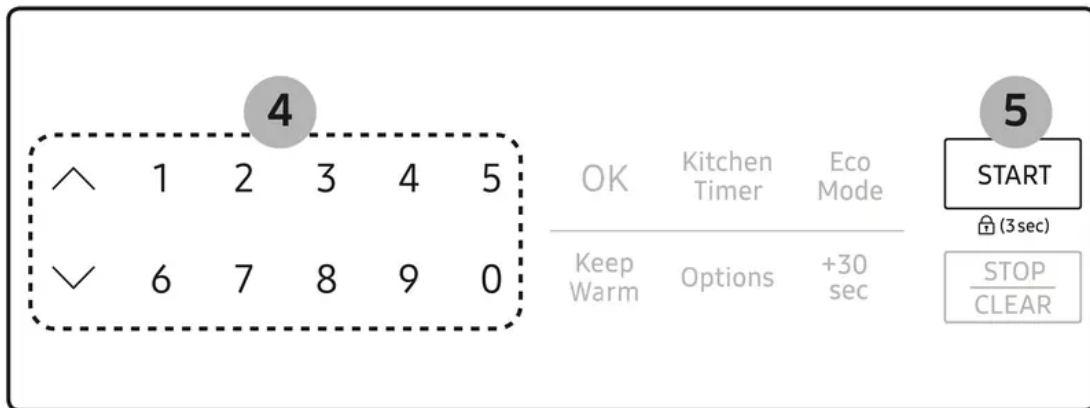

5. Press the START button to begin cooking.



Kids Meals table

Menu / Item		No. / Amount		Instructions
1	Chicken nuggets (frozen)	1	1 serving	Place a paper towel on a plate and arrange the nuggets in a spoke-like fashion on the paper towel. Do not cover. Let stand for 1 minute after heating. NOTE Refer to the package directions for the serving size and the amount of food.
		2	2 servings	



Menu / Item		No. / Amount		Instructions
2	French fries (frozen)	1	1 serving	Place two paper towels on a microwave-safe plate and arrange the French fries on the towels without letting them overlap. Blot the fries with additional paper towels after removing from the oven. Let stand for 1 minute.  NOTE Refer to the directions on the packaging for the serving size and the amount of food.
		2	2 servings	
3	Frozen sandwiches (in crisping sleeve) 9-oz package size	1	1 sandwich	Place the frozen sandwich in a susceptor “crisping sleeve” (which is in the package) and place on a microwave-safe plate. Remove from the “crisping sleeve”. Let stand for 2 minutes after heating.
		2	2 sandwiches	
4	Hot dogs	1	2 hot dogs	Pierce the hot dogs and place them on a plate. When the oven beeps, add the buns and restart the oven. Let stand for 1 minute after heating.  NOTE For the best texture, the buns should be added to the hot dogs when the oven beeps.
		2	4 hot dogs	

Using the snacks button

1. Press the Snacks button.
2. Press the Up/Down buttons or numeric buttons to select the item. (Refer to the Snacks table below for a list of the items.)

3. Press the OK button.

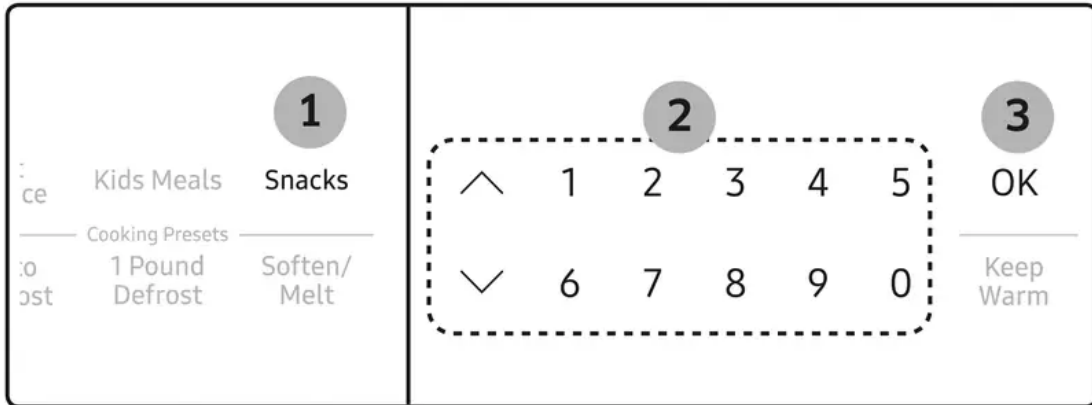

4. Press the Up/Down buttons or numeric buttons to select the serving size. You can cook only 1 serving for Nachos. (Refer to the Snacks table for the serving size.)

5. Press the START button to begin cooking.

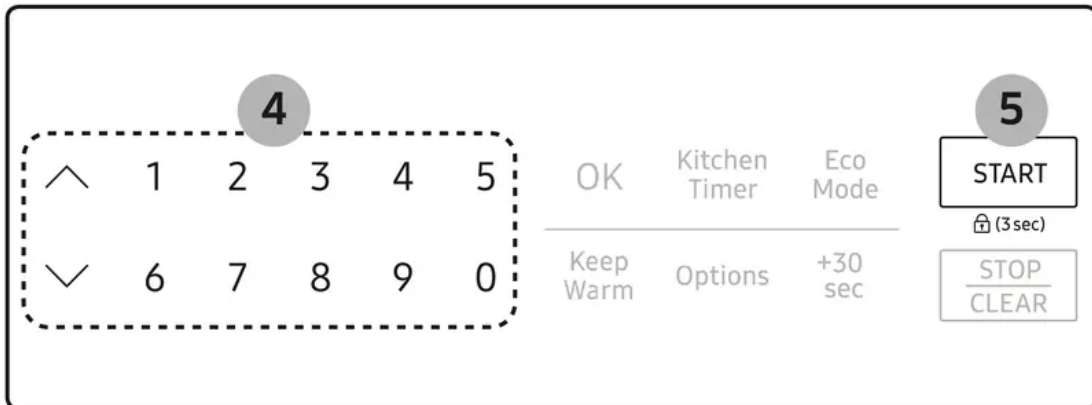

Snacks table



Menu / Item		No. / Amount		Instructions
1	Cheese sticks (frozen)	1	5-6 pcs (1 Srv.)	Place the cheese sticks on a plate in a spoke-like fashion. Do not cover. Let stand for 1 to 2 minutes after heating.
		2	7-10 pcs (2 Srvs.)	
2	Chicken wings	1	5-6 oz. (1 Srv.)	Use precooked, refrigerated chicken wings. Place the chicken wings around the plate in a spoke-like fashion and cover with wax paper. Let stand for 1 to 2 minutes.
		2	7-8 oz. (2 Srvs.)	
3	Nachos	1	1 serving	Place the nachos on a plate without letting them overlap. Sprinkle cheese evenly over them. Contents: 2 cups tortilla chips ½ cup grated cheese
4	Potato skins	1	1 cooked potato	Cut the cooked potato into 4 even wedges. Scoop or cut out the potato flesh, leaving about a ¼ in. of skin. Place the skins in a spoke-like fashion around the plate. Sprinkle with bacon, onions and cheese. Do not cover. Let stand 1 to 2 minutes.
		2	2 cooked potatoes	

Using the soften/melt button

1. Press the Soften/Melt button.
2. Press the Up/Down buttons or numeric buttons to select the item. (Refer to the Soften/Melt table below for a list of the items.)
3. Press the OK button.

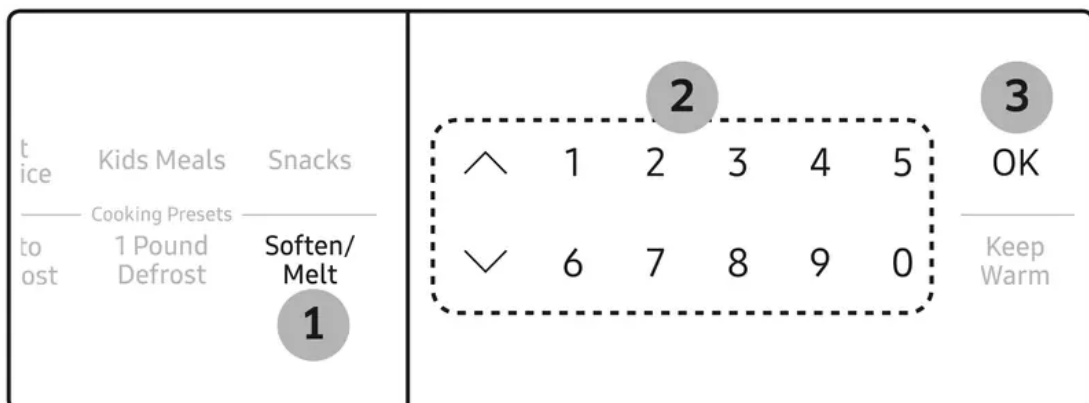

4. Press the Up/Down buttons or numeric buttons to select the amount. You can cook only 1 serving using the Melt Chocolate, Soften Butter, and Soften Cream Cheese options. (Refer to the Soften/Melt table for the serving size.)
5. Press the START button to begin cooking.

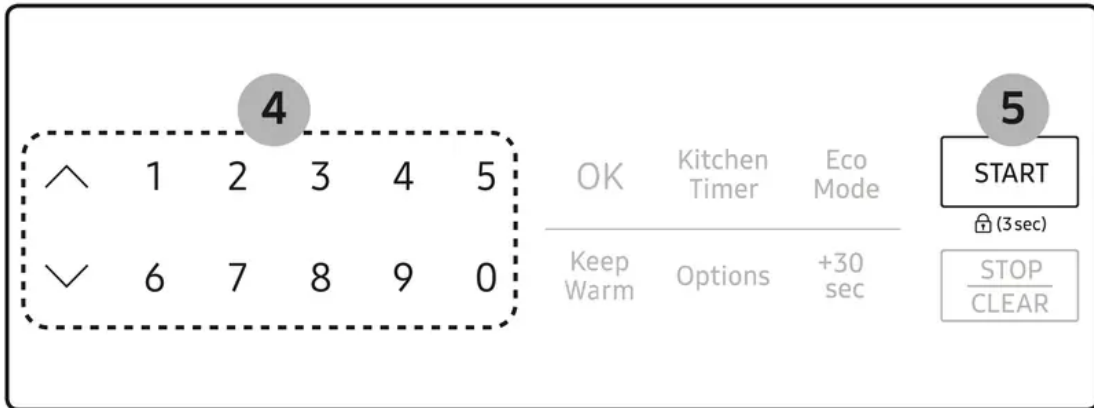

Soften/Melt table

Menu / Item		No. / Amount		Instructions
1	Melt butter	1	1 stick	Remove the wrapping and cut the butter in half vertically. Place the butter in a dish and cover with wax paper. Stir well after finishing and let stand for 1-2 minutes.
		2	2 sticks	
2	Melt chocolate	1	1 cup chips or 1 square	Place the chocolate chips or squares in a microwave-safe container. When the oven beeps, stir the chocolate and restart the oven. Stir and let stand for 1 minute.
3	Soften butter	1	1 stick (¼ lbs.)	Remove wrapping and cut butter in half vertically. Place butter in dish, cover with wax paper.
4	Soften cream cheese	1	1 package (8 oz.)	Unwrap the cream cheese and place on a microwave-safe container. Cut in half vertically. Let stand for 2 minutes.

Cookware guide

To cook food in your microwave oven, microwaves must be able to penetrate the food without being reflected or absorbed by the cookware holding the food. Consequently, it is important to choose cookware that both allows microwaves to penetrate food and is microwave-safe.

The following lists contain various types of cookware and indicate if and how the cookware should be used in a microwave oven.

Recommended cooking utensils

- **Glass and glass-ceramic bowls and dishes** — Use for heating or cooking.
- **Microwavable plastic wrap** — Use to cover. Leave a small opening for steam to escape and avoid placing it directly on the food.
- **Wax paper** — Use as a cover to prevent spattering.
- **Paper towels and napkins** — Use for short-term heating and covering. They absorb excess moisture and prevent spattering. Do not use recycled paper towels, which may contain metal and can catch fire.
- **Paper plates and cups** — Use for short-term heating at low temperatures. Do not use recycled paper, which may contain metal and can catch fire.
- **Thermometers** — Use only those labeled “Microwave Safe” and follow all directions. Check the food in several places. Conventional thermometers may be used once the food has been removed from the oven.

Limited use items

- **Aluminum foil** — Use narrow strips of foil to prevent overcooking of exposed areas. Using too much foil can damage your oven, so be careful.
- **Ceramic, porcelain, and stoneware** — Use these if they are labeled “Microwave Safe”. If they are not labeled, test them to make sure they can be used safely. Never use dishes with metallic trim.
- **Plastic** — Use only if labeled “Microwave Safe”. Other plastics can melt.
- **Straw, wicker, and wood** — Use only for short-term heating, as they are flammable.

Not recommended

- **Glass jars and bottles** — Regular glass is too thin to be used in a microwave and can shatter.
- **Paper bags** — These are a fire hazard, except for popcorn bags that are designed for microwave use.
- **Styrofoam plates and cups** — These can melt and leave an unhealthy residue on food.

- **Plastic storage and food containers** — Containers such as margarine tubs can melt in the microwave.

Testing utensils

If you are not sure whether a dish is microwave-safe or not, you can perform this test:

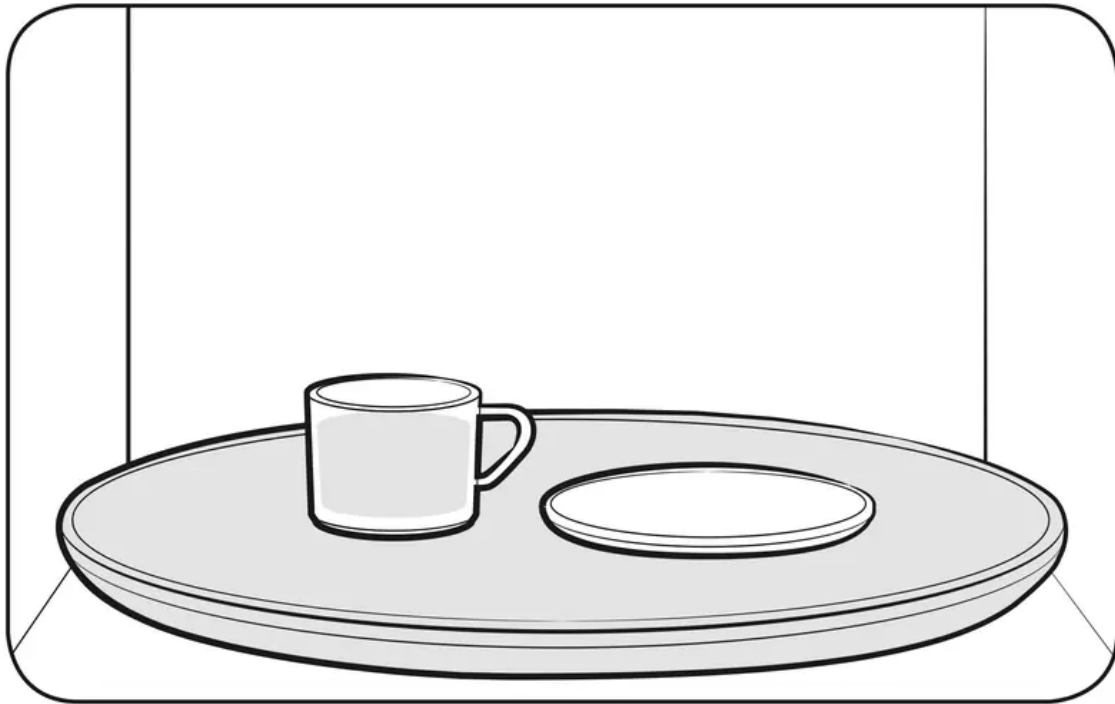

1. Fill a 1 cup glass measuring cup with water and put it inside your oven, next to the dish you want to test.
2. Set the microwave to 1 minute using the numeric buttons, and then press the START button. This will heat the glass and dish for one minute at High power.

When the microwave stops, the water should be warm and the dish you are testing should be cool. If the dish is warm, then it is absorbing microwave energy and is not acceptable for use in the microwave.

Microwave energy actually penetrates food and is attracted to and absorbed by the water, fat, and sugar molecules in the food. The microwaves cause the molecules in the food to move rapidly. The rapid movement of these molecules creates friction and the resulting heat cooks the food.

Cooking techniques

Stirring

Stir foods such as casseroles and vegetables while cooking to distribute heat evenly. Food at the outside of the dish absorbs more energy and heats more quickly, so stir from the outside to the center. The oven will turn off when you open the door to stir your food.

Arrangement

Arrange unevenly shaped foods, such as chicken pieces or chops, with the thicker, meatier parts toward the outside of the turntable where they will receive more microwave energy. To prevent overcooking, place thin or delicate parts toward the center of the turntable.

Shielding

Shield food with narrow strips of aluminum foil to prevent overcooking. Areas that need shielding include poultry wing-tips, the ends of poultry legs, and the corners of square baking dishes. Use only small amounts of aluminum foil. Larger amounts can damage your oven.

Turning

Turn foods over midway through cooking to expose all parts to microwave energy. This is especially important with large items such as roasts.

Standing

Food cooked in the microwave builds up internal heat and continues to cook for a few minutes after the oven stops. Let food stand to complete cooking, especially food such as roasts and whole vegetables. Roasts need this time to complete cooking in the center without overcooking the outer areas. All liquids, such as soup or hot chocolate, should be shaken or stirred when cooking is complete. Let liquids stand a moment before serving. When heating baby food, stir well and test the temperature before serving.

Adding Moisture

Microwave energy is attracted to water molecules. Food that is uneven in moisture content should be covered or allowed to stand so that the heat disperses evenly. Add a small amount of water to dry food to help it cook.

Venting

After covering a dish with plastic wrap, vent the plastic wrap by turning back one corner so excess steam can escape.

General cooking recommendations

- Dense foods, such as potatoes, take longer to heat than lighter foods. Food with a delicate texture should be heated at a low power level to prevent it from becoming tough.
- Altitude and the type of cookware you are using can affect cooking time. When trying a new recipe, use the minimum cooking time and check the food occasionally to prevent overcooking.
- Food with a non-porous skin such as potatoes or hot dogs should be pierced to prevent bursting.
- Frying with oil or fat is not recommended. Fat and oil can suddenly boil over and cause severe burns.

- Some ingredients heat faster than others. For example, the jelly inside a jelly doughnut will be hotter than the dough. Keep this in mind to avoid burns.
- Home canning in the microwave oven is not recommended because all harmful bacteria may not be destroyed by the microwave heating process.
- Although microwaves do not heat the cookware, the heat from the food is often transferred to the cookware. Always use pot holders when removing food from the microwave and instruct children to do the same.
- Making candy in the microwave is not recommended as candy can heat to very high temperatures. Keep this in mind to avoid injury.

Guide for cooking eggs in your microwave

- Never cook eggs in the shell and never warm hard-cooked eggs in the shell. They can explode.
- Always pierce whole eggs to keep them from bursting.
- Cook eggs just until set. They become tough if overcooked.

Guide for cooking vegetables in your microwave

- Vegetables should be washed just before cooking. Often, no extra water is needed. If you are cooking dense vegetables such as cubed potatoes, carrots, or green beans, add about $\frac{1}{4}$ cup water.
- Small vegetables (sliced carrots, peas, lima beans, etc.) will cook faster than larger ones.
- Whole vegetables, such as potatoes, acorn squash, or corn on the cob, should be arranged in a circle on the turntable before cooking. They will cook more evenly if turned over after half the cooking time.
- Always place vegetables like asparagus and broccoli with the stem ends pointing towards the edge of the dish and the tips toward the center.
- When cooking cut vegetables, always cover the dish with a lid or vented microwavable plastic wrap.
- Whole, unpeeled vegetables such as potatoes, squash, eggplant, etc., should have their skin pricked in several spots before cooking to prevent them from bursting.
- For more even cooking, stir or rearrange whole vegetables halfway through the cooking time.
- Generally, the denser the food, the longer the standing time. (Standing time refers to the time necessary for dense, large foods and vegetables to finish cooking after they come out of the oven.) A baked potato can stand on the counter for five minutes before cooking is completed, while a dish of peas can be served immediately.

Cleaning and maintaining your microwave oven

Keeping your microwave oven clean improves its performance, wards off unnecessary repairs, and lengthens its life.

Cleaning the exterior

It's best to clean spills on the outside of your microwave oven as they occur. Use a soft cloth and warm, soapy water. Rinse and dry.

CAUTION: Do not get water into the vents. Never use abrasive products or chemical solvents such as ammonia or alcohol as they can damage the appearance of your microwave.

WARNING: Unplug the microwave plug before cleaning.

Cleaning under your microwave oven

Regularly clean grease and dust from the bottom of your microwave using a solution of warm water and detergent.

Cleaning the control panel

Wipe with a damp cloth and dry thoroughly. Do not use cleaning sprays, large amounts of soap and water, abrasives, or sharp objects on the panel as it is easily damaged.

Cleaning the door and door seals

Always ensure that the door seals are clean and that the door closes properly. Take particular care when cleaning the door seals to ensure that no particles accumulate and prevent the door from closing correctly. Wash the glass door with very mild soap and water. Be sure to use a soft cloth to avoid scratching.

NOTE: If steam accumulates inside or outside the oven door, wipe with a soft cloth. Steam can accumulate when you operate the oven when humidity is high and in no way indicates microwave leakage.

Cleaning the interior

CAUTION: To avoid injury, ensure that the microwave oven has cooled down before cleaning it.

CAUTION: Remove the glass tray from the oven when cleaning the oven or tray. To prevent the tray from breaking, handle it with care and do not put it in water immediately after cooking. Wash the tray carefully in warm sudsy water or in the dishwasher.

Cleaning the turntable and roller rings

Clean the roller rings periodically and wash the turntable as required. The turntable can be washed safely in your dishwasher.

Storing and repairing your microwave oven

If you need to store your microwave oven for a short or extended period of time, choose a dust-free, dry location. Dust and dampness may adversely affect the functionality of the microwave parts.

WARNING:

- Do not repair, replace, or service any part of your microwave oven yourself. Allow only a qualified service technician to perform repairs. If the oven is faulty and needs servicing, or you are in doubt about its condition, unplug the oven from the power outlet and contact your nearest service center.
- Do not use the oven if the microwave oven is damaged, in particular, if the door or door seals are damaged or the door does not close properly. This can be caused by a broken hinge, a worn out seal or distorted/bent casing.
- Do not remove the oven from its casing.
- This microwave oven is for home use only and is not intended for commercial use.

Replacing the cooktop/night light

When replacing the cooktop/night light, make sure that you are wearing gloves to avoid injury from the heat of the lamp.

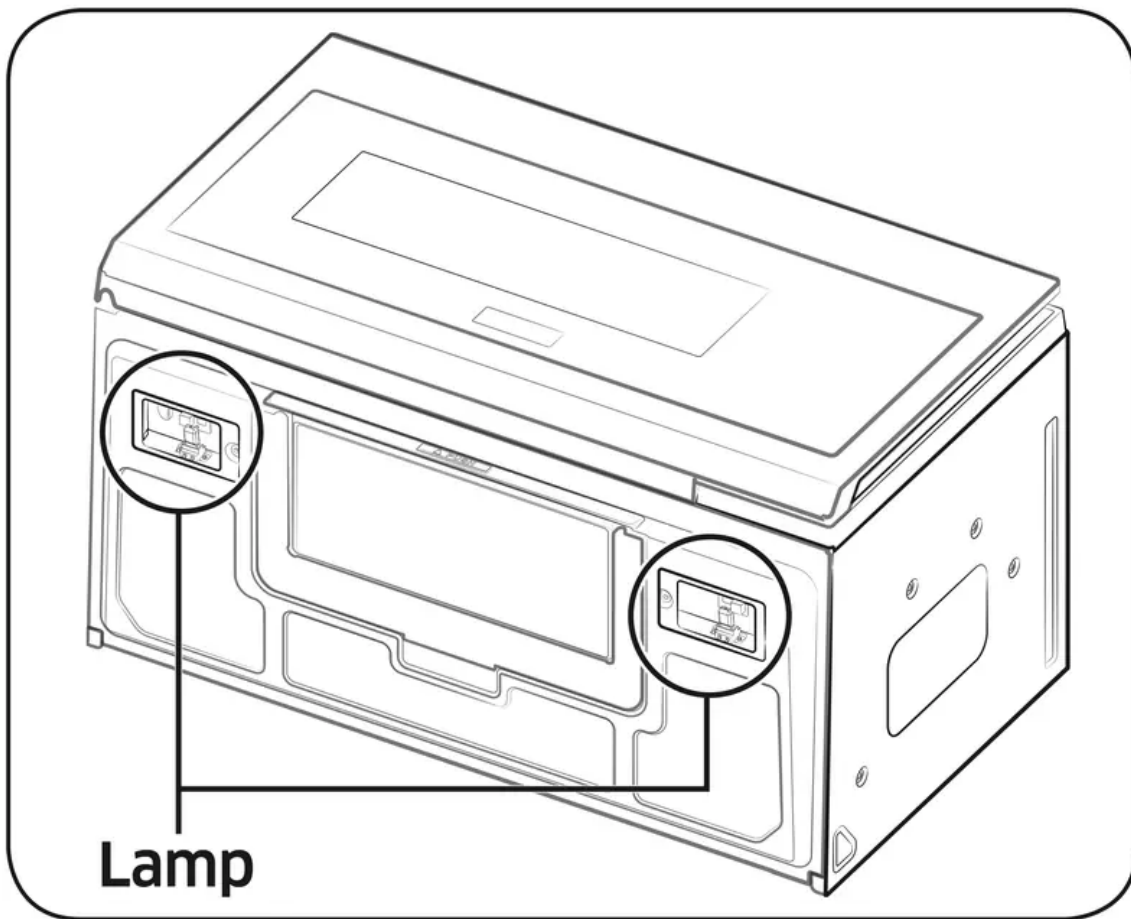

1. Unplug the oven or turn off the power at the main power supply.
2. Remove the screw from the light cover and lower the cover.
3. Disconnect the wire connectors.
4. Remove the screw securing the LED lamp board.
5. Replace the LED lamp board.

NOTE: To purchase a new LED lamp board, visit an authorized Samsung service center or call 1-800-SAMSUNG (726-7864).

Replacing the oven light

When replacing the oven light, make sure that you are wearing gloves to avoid injury from the heat of the lamp.

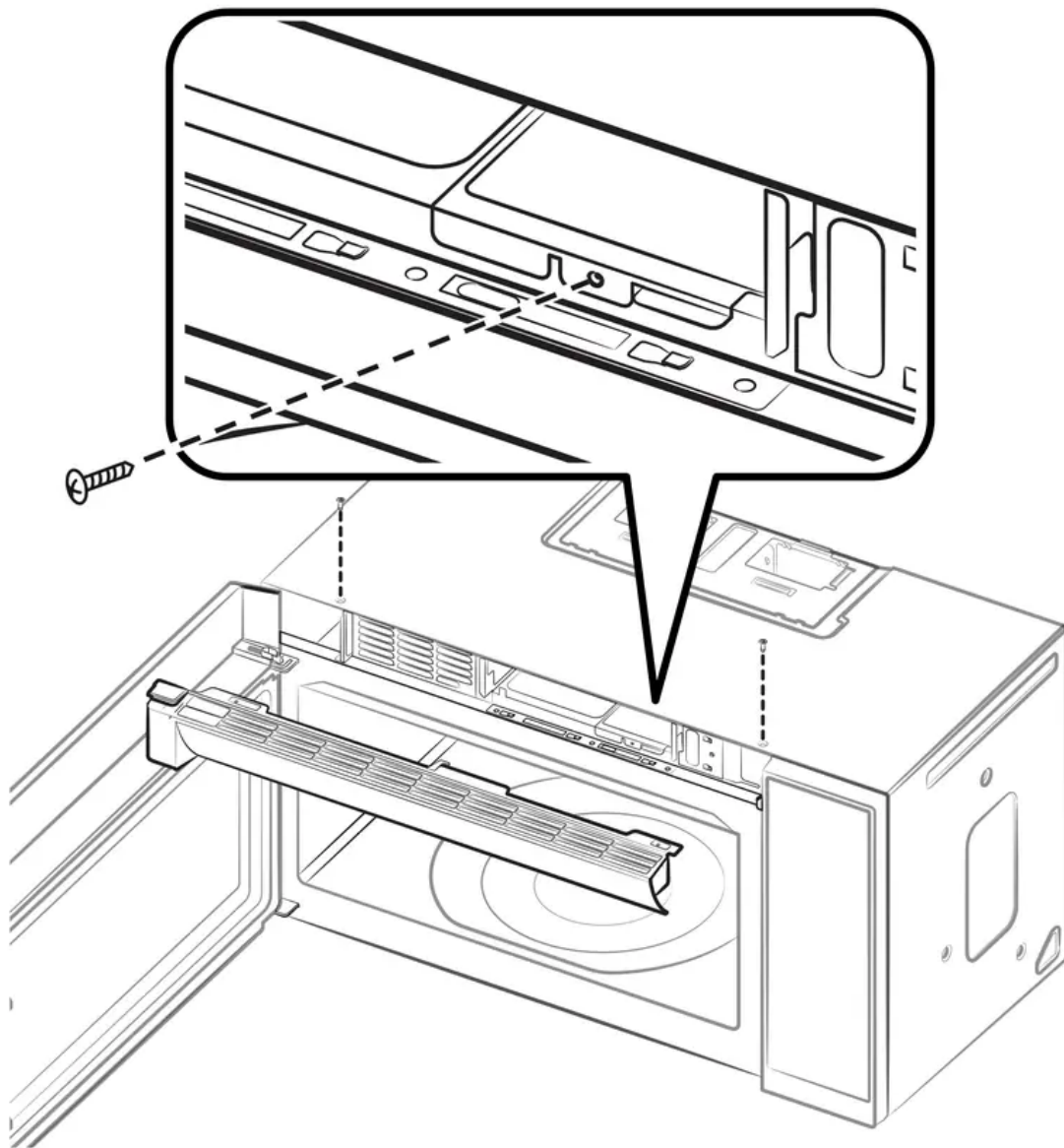

1. Unplug the oven or turn off the power at the main power supply.
2. Open the door.
3. Remove the vent cover mounting screws (2 middle screws).
4. Slide the vent grille to the left, then pull it straight out.
5. Remove the charcoal filter, if present.
6. Remove the screw securing the lamp cover.
7. Remove the lamp by pulling it out gently.
8. Replace the lamp with a 50 watt halogen lamp.
9. Replace the lamp holder.
10. Replace the vent grille and re-insert the 2 screws.
11. Plug the oven in or turn on the power at the main power supply. Reset the clock.

Cleaning the grease filter

WARNING: To avoid the risk of personal injury or property damage, do not operate the oven hood without the filter in place.

1. To remove the filter, push the front of the grease filter case where it says "PUSH".

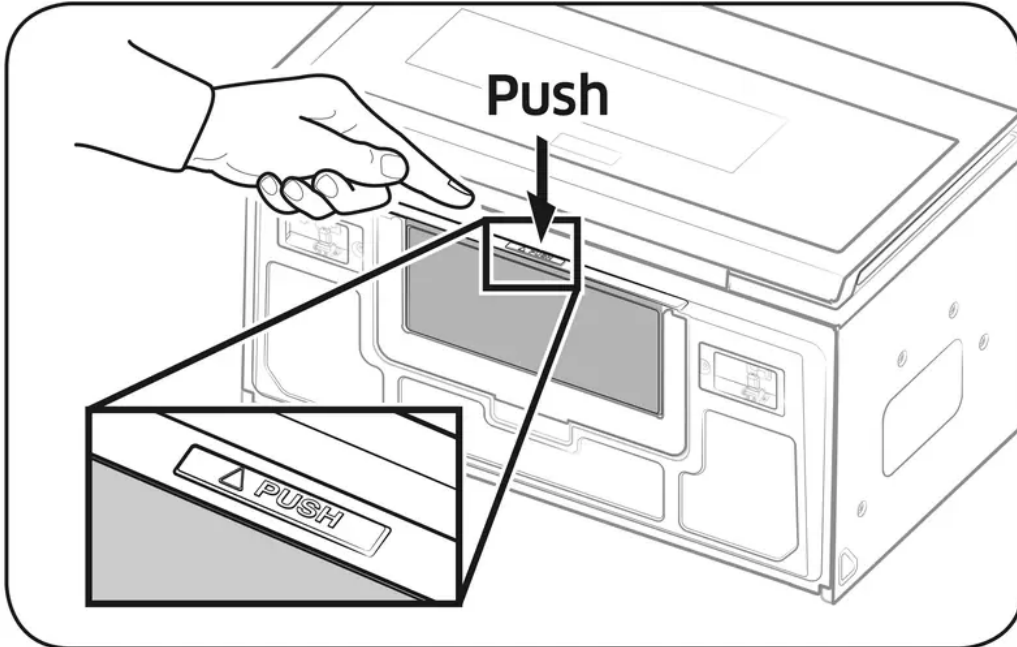

2. Pull the filter case out of the microwave oven.

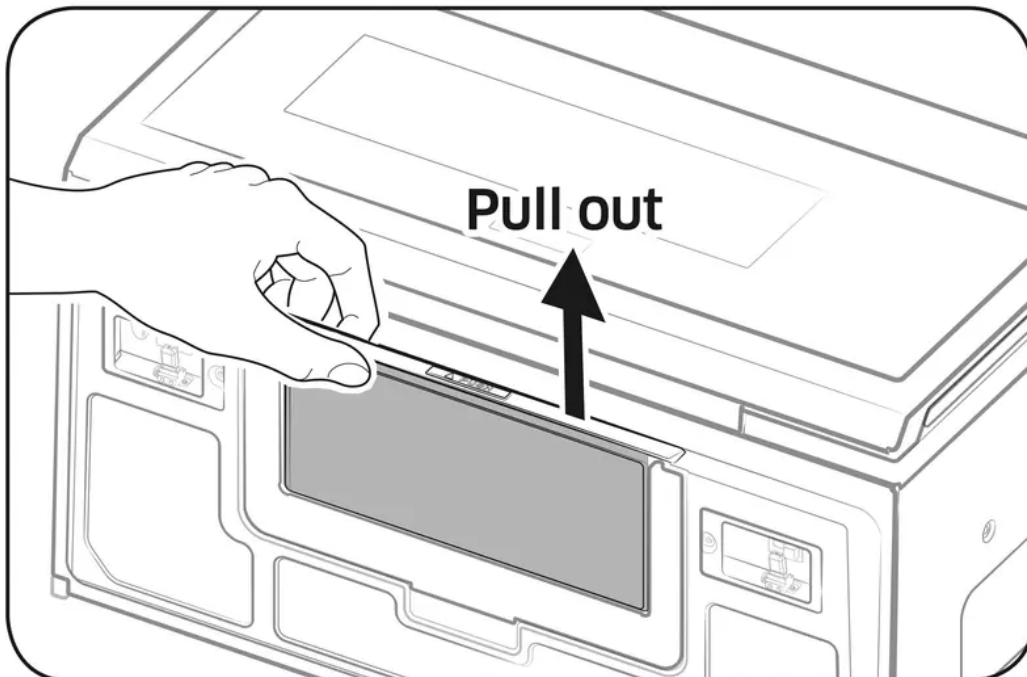

3. Remove the filter from the filter case by widening the case, as shown below. Then, soak the grease filter in hot water mixed with a mild detergent. Rinse well and shake to dry. If necessary, brush the filter lightly to remove embedded dirt. When the filter is dry, put it back in the filter case.

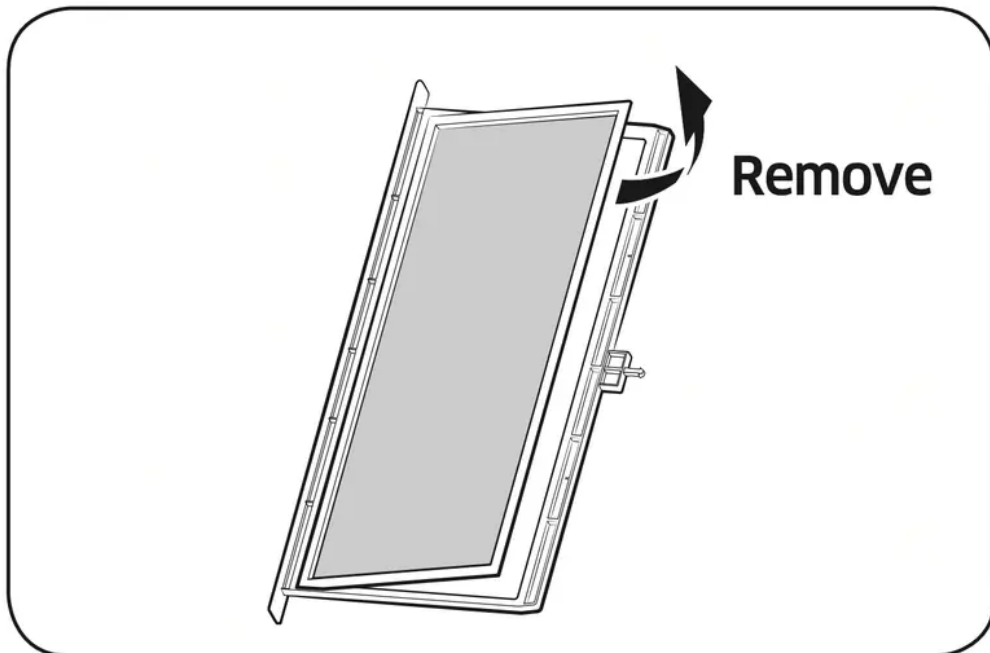
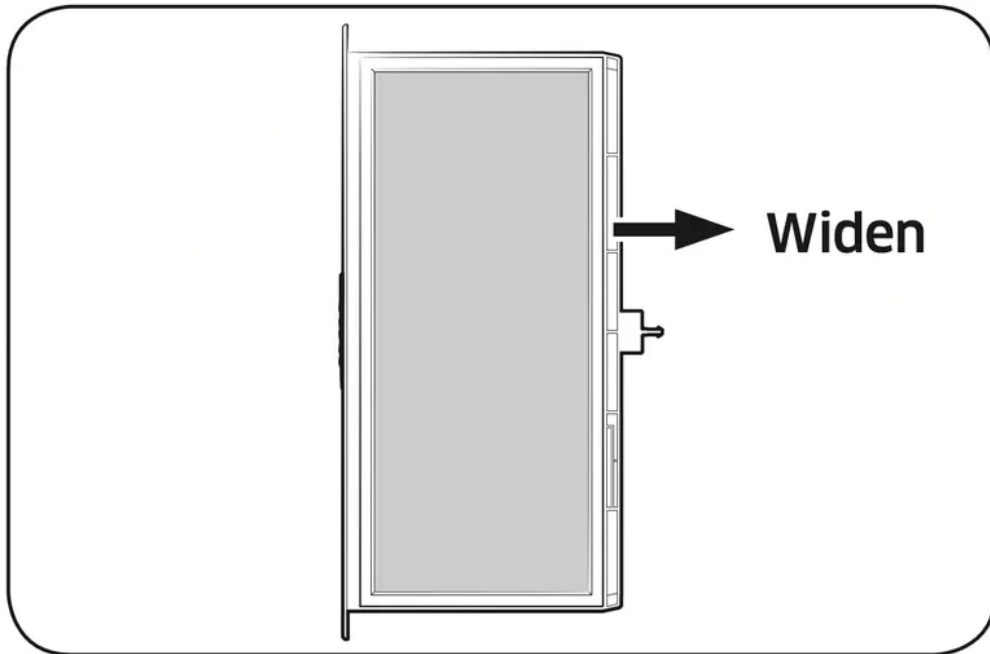

WARNING: Do not use ammonia or put the grease filter in the microwave oven to dry.

The aluminum will darken.

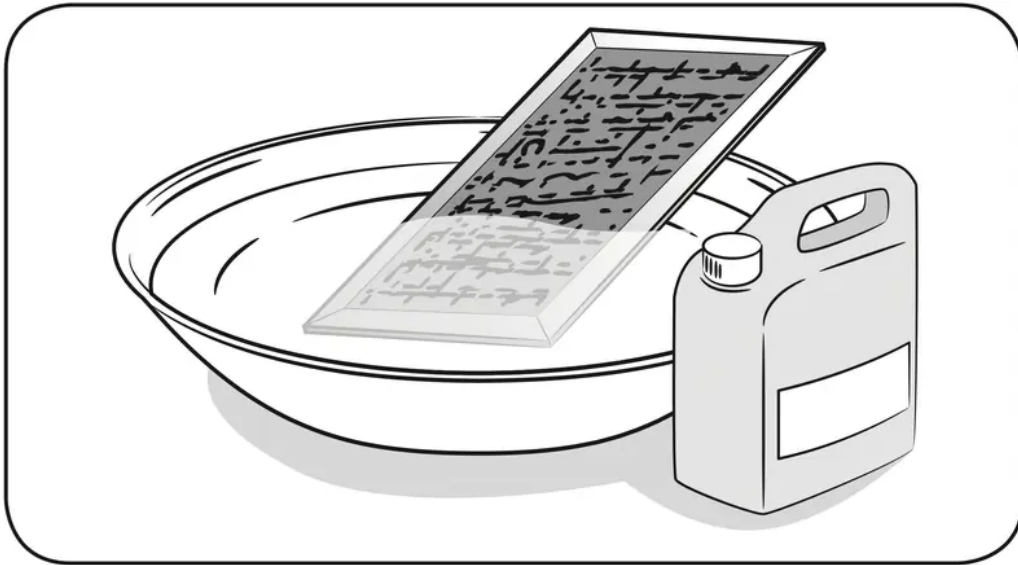

4. To re-insert the filter into the microwave oven, slide the filter case into the frame slot, and then push it inside.

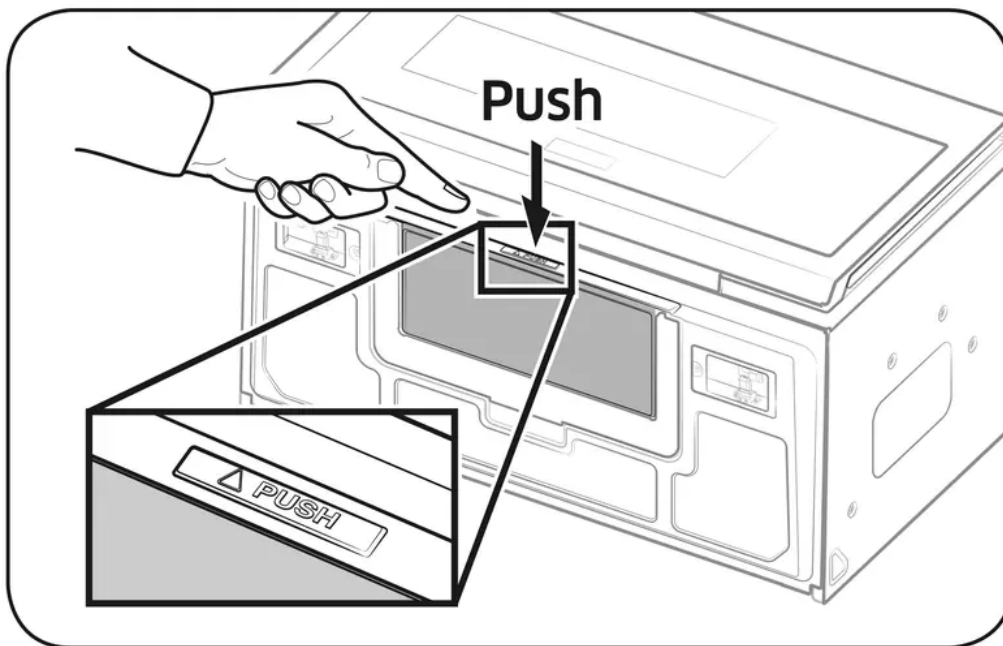

Replacing the charcoal filter

If your oven is vented to the inside, the charcoal filter should be replaced every 6 to 12 months and more often if necessary. The charcoal filter cannot be cleaned.

The filter angle

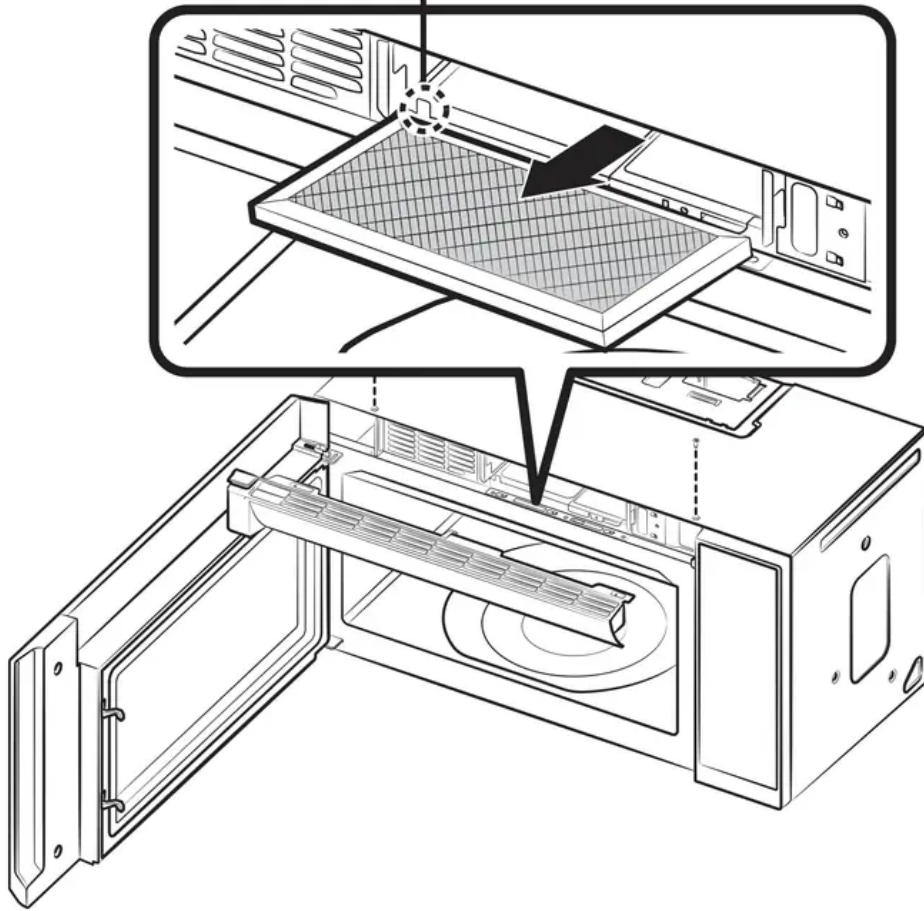

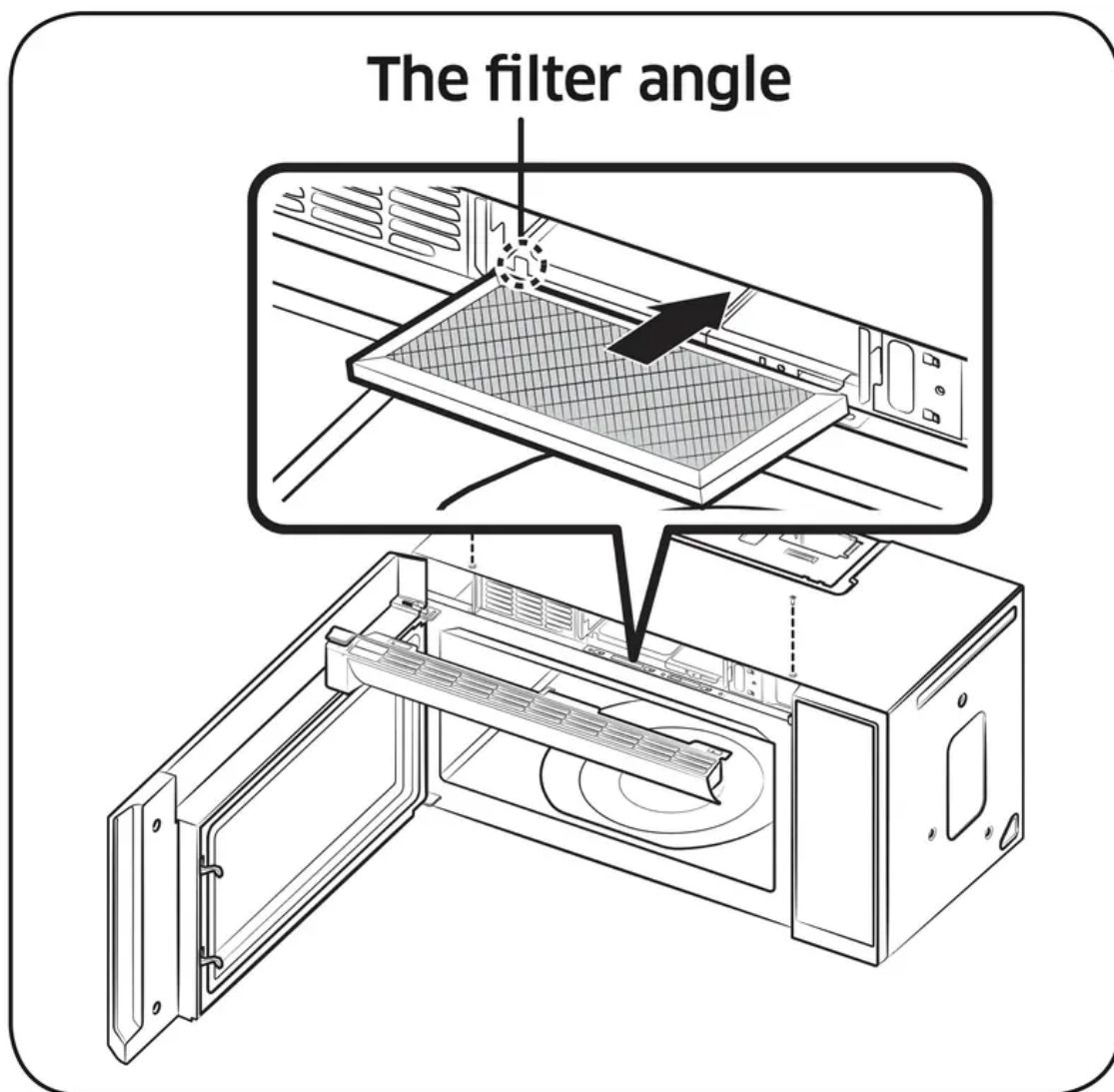

1. Unplug the oven or turn off the power at the main power supply.
2. Open the door.
3. Remove the vent grille mounting screws (2 middle screws).
4. Slide the vent grille to the left, then pull it straight out.
5. Push the hook and remove the old filter.
6. Slide a new charcoal filter into place.
The filter should rest at the angle shown.
7. Replace the vent grille and 2 screws, and then close the door. Plug the oven in or turn on the power at the main power supply. Reset the clock.

Troubleshooting

Check points

If you encounter a problem with your oven, first check the tables starting below and try the recommendations. If a problem persists, or if an information code keeps appearing on the display, contact a local Samsung service center.

Problem	Cause	Action
General		
The buttons cannot be pressed properly.	Foreign matter may be caught between the buttons.	Remove the foreign matter and try again.
	For touch models: Moisture is on the exterior.	Wipe the moisture from the exterior.
	The Child Lock is activated.	Deactivate the Child Lock.
The time is not displayed.	Power is not supplied.	Make sure power is supplied. Confirm the microwave is plugged in. Check your fuses or circuit breakers.
	The Eco (power-saving) function is set.	Turn off the Eco function.
The oven does not work.	Power is not supplied.	Make sure power is supplied. Confirm the microwave is plugged in. Check your fuses or circuit breakers.
	The door is open.	Close the door and try again.
	The door open safety mechanisms are covered by foreign matter.	Remove the foreign matter and try again.
The oven stops while in operation.	The user has opened the door to turn food over.	After turning over the food, press the START button again to start operation.
The power turns off during operation.	The oven has been cooking for an extended period of time.	After the oven has cooked for an extended period of time, let the oven cool.
	The cooling fan is not working.	Listen for the sound of the cooling fan.

Problem	Cause	Action
	Trying to operate the oven without food inside.	Put food in the oven.
	There is not enough ventilation space around the oven.	There are intake/exhaust outlets on the front and rear of the oven for ventilation. Check the installation guide and make sure that the microwave is far enough away from walls and cabinets for proper ventilation.
	Several appliances or devices are plugged into the same outlet.	Unplug all other appliances or devices from the outlet.
There is no power to the oven.	Power is not supplied.	Make sure power is supplied. Confirm the microwave is plugged in. Check your fuses or circuit breakers.
There is a popping sound during operation, and the oven doesn't work.	Cooking food in a sealed container or using a container with a tight lid.	Do not cook food in sealed containers or in containers with tight lids. Expanding steam from the cooking food can cause the containers to burst or the lids to pop off.
The oven exterior gets too hot during operation.	There is not enough ventilation space around the oven.	There are intake/exhaust outlets on the front and rear of the oven for ventilation. Check the installation guide and make sure that the microwave is far enough away from walls and cabinets for proper ventilation.
	Objects are on top of the oven.	Remove all objects on the top of the oven.
The door cannot be opened properly.	Food residue is stuck between the door and oven interior.	Clean the oven the door.
The oven does not heat.	The oven may not work if too much food is being cooked or	To test the oven, put one cup of water in a microwave-safe container, put the container in the oven, and then run the

Problem	Cause	Action
	improper cookware is being used.	microwave for 1-2 minutes to check whether the water is heated. If the water is heated, reduce the amount of food and start the function again. Use a cooking container with a flat bottom.
Heating is weak or slow.	The oven may not work if too much food is being cooked or improper cookware is being used.	To test the oven, put one cup of water in a microwave-safe container, put the container in the oven, and then run the microwave for 1-2 minutes to check whether the water is heated. If the water is heated, reduce the amount of food and start the function again. Use a cooking container with a flat bottom.
The warm function does not work.	The oven may not work if too much food is being warmed or improper cookware is being used.	To test the oven, put one cup of water in a microwave-safe container, put the container in the oven, and then run the microwave for 1-2 minutes to check whether the water is heated. If the water is heated, reduce the amount of food and start the function again. Use a cooking container with a flat bottom.
The thaw function does not work.	The oven may not work if too much food is being thawed or improper cookware is being used.	To test the oven, put one cup of water in a microwave-safe container, put the container in the oven, and then run the microwave for 1-2 minutes to check whether the water is heated. If the water is heated, reduce the amount of food and start the function again. Use a cooking container with a flat bottom.
The interior light is dim or does not turn on.	The door has been left open for a long time.	The interior light may automatically turn off when the Eco function operates. Close and reopen the door or press the STOP/CLEAR button.
	The interior light is covered by foreign matter.	Clean the inside of the oven and check again.

Problem	Cause	Action
A beeping sound occurs during cooking.	If the Auto Cook function is being used, this beeping sound means it's time to turn over the food.	After turning over the food, press the START button again to restart operation.
The oven is not level.	The oven is installed on an uneven surface.	Make sure the oven is installed on flat, stable surface.
There are sparks during cooking.	Metal containers are used during cooking or thawing.	Do not use metal containers.
When power is connected, the oven immediately starts to work.	The door is not properly closed.	Close the door and check again.
There is electricity coming from the oven.	The power source or power outlet is not properly grounded.	Make sure the power source and power outlet are properly grounded.
There is water dripping.	Water or steam may be generated by the cooking or defrosting process, depending on the food. This is not an oven malfunction.	Let the oven cool and then wipe with a dry dish towel.
There is steam coming through a crack in the door.	Water or steam may be generated by the cooking or defrosting process, depending on the food. This is not an oven malfunction.	Let the oven cool and then wipe with a dry dish towel.
There is water left in the oven.	Water or steam may be generated by the cooking or defrosting process, depending on	Let the oven cool and then wipe with a dry dish towel.

Problem	Cause	Action
	the food. This is not an oven malfunction.	
The brightness inside the oven varies.	Changes in brightness reflect changes in power output. Power output changes depending on the functions in use.	Power output changes during cooking are not malfunctions.
Cooking is finished, but the cooling fan is still running.	To ventilate the oven, the cooling fan continues to run for about 3 minutes after cooking is complete.	This is not an oven malfunction.
Pressing the START button operates the oven.	This happens when the oven is not operating.	The microwave oven is designed to start operating when you press the START button if it was not operating.
Turntable		
While turning, the turntable comes out of place or stops turning.	There is no roller ring, or the roller ring is not properly in place.	Install the roller ring properly and then try again.
The turn table drags while turning.	The roller ring is not properly in place, there is too much food, or the container is too large and touches the inside of the microwave.	Install the roller ring properly. Adjust the amount of food. Do not use containers that are too large.
The turn table rattles while turning and is noisy.	Food residue is stuck to the bottom of the oven.	Remove any food residue stuck to the bottom of the oven

Information codes

If the microwave oven fails to operate, you may see an information code on the display. Check the table below for the code, and then follow the directions.

Code	Description	Action
C-10	The GAS sensor is open.	Unplug the power cord of the oven, and then contact a local Samsung service center.
	The GAS sensor is shorted.	
C-F0	The microwave has sensed an internal communications failure.	Unplug the power cord of the oven, and then contact a local Samsung service center.
C-F2	A touch button has malfunctioned.	Press STOP/CLEAR, and then try the button again.

Warning

This content is compiled from multiple sources and is provided for reference purposes only. It may not be complete or fully applicable to all situations. If you are unable to resolve your issue, please contact the product manufacturer or an authorized service provider for official support.