

User manual Microwave

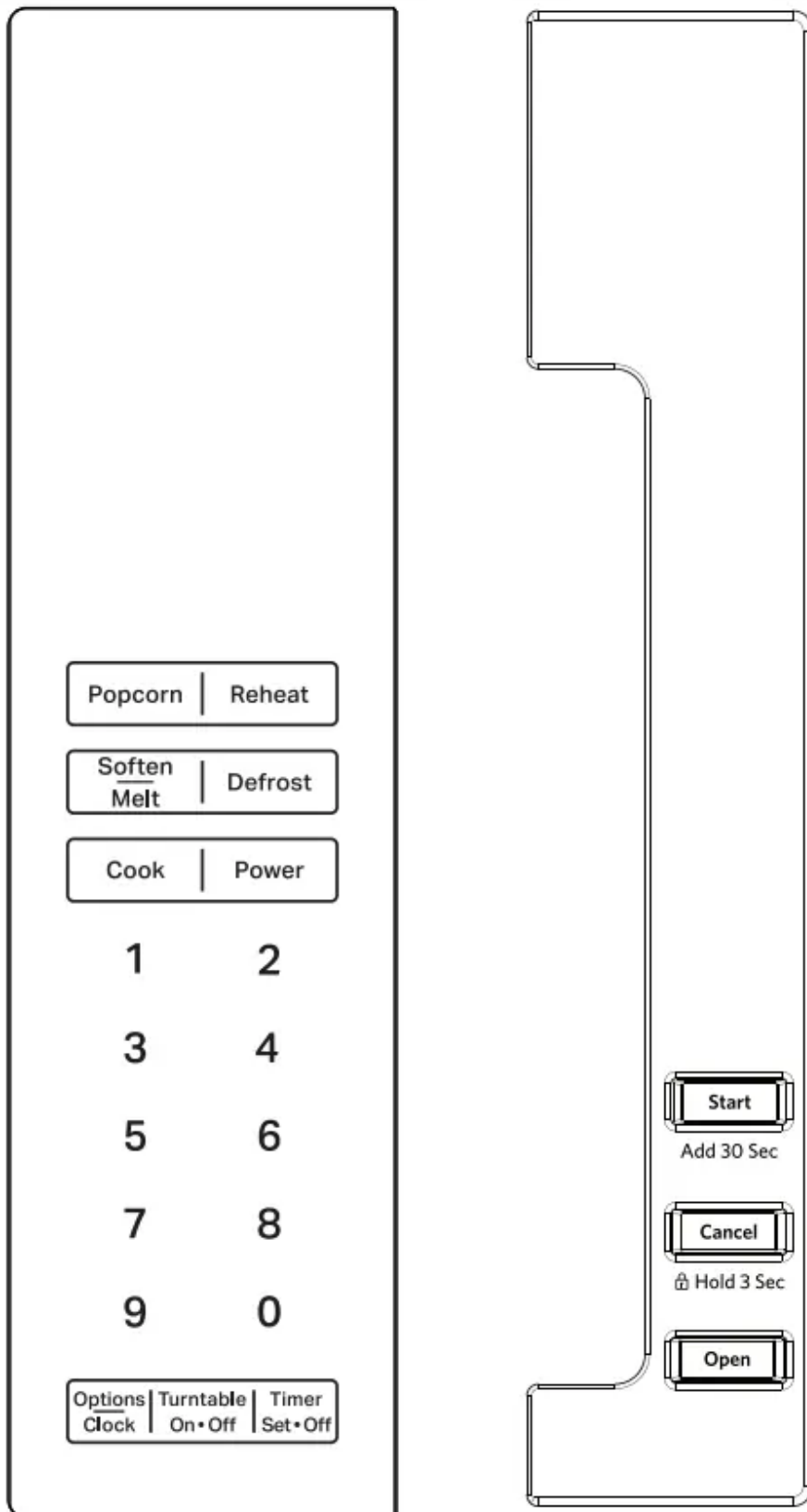

FEATURES

Feature Guide



Keypad	Feature	Instructions
Options/ Clock	Set the Clock	<p>This microwave uses a 12 hour clock (1:00 - 12:59). To set the clock, follow the instructions below:</p> <ol style="list-style-type: none"> 1. Press the OPTIONS/CLOCK button repeatedly until Clock is displayed. 2. Press the number keys to set the clock. 3. Press START or OPTIONS/CLOCK to save the time. <p>NOTE:</p> <ul style="list-style-type: none"> • After power loss, it may be necessary to reset the clock. • The default clock value in the memory is “ : ”
Timer Set/ Off	Set Kitchen Timer	<p>The kitchen timer functions independently of the microwave cooking functions, similar to a stop watch. To set the kitchen timer, follow the instructions below:</p> <ol style="list-style-type: none"> 1. Touch TIMER button. 2. Use the number keys to enter a time up to 99 minutes and 59 seconds. 3. For example, to set a 12 minute timer, press the TIMER button and use the number keys to enter 12:00. 4. Touch the START button. <p>Note: When Kitchen Timer is running: The Add 30 Sec button will not work</p> <p>To reset the timer: Press TIMER button. The display will show 00:00. Follow the above steps to set the timer.</p> <p>To run manual cooking mode: Press POWER button to set the power level, and press POWER button again to set the cooking time.</p> <p>To run an auto cooking mode: Press POPCORN/ COOK/REHEAT/DEFROST/ SOFTEN OR MELT button</p>

	Add 30 Seconds	<p>The START button can be used in two ways:</p> <ol style="list-style-type: none"> 1. To start the microwave by cooking for 30 seconds using the most recent power setting. 2. To increase a cooking time using increments of 30 seconds. Each press adds 30 seconds or pressing and holding the START button will add more time automatically. <p>For example:</p> <p>To add 30 seconds of cook time, press the START button once.</p> <p>To add 1 minute of cooking time, press the START button twice.</p> <p>To add more time, press and hold START button until your preferred cook time is reached.</p> <p>Note: Holding the START button will add up to 10 minutes to the current time countdown. When 10 minutes has been added or the max time has been reached, invalid/retry tones will sound and the display will show the final time setting. If you want more time, you can release the keypad, then press and hold the START button again to add up to another 10 minutes.</p>
	Start Function	<p>Press the START button to start any cooking function. If cooking is interrupted by opening the door, touch the START button after the door is closed again to resume the cycle.</p>
	Microwave Oven Cancel	<p>The CANCEL button stops any microwave oven function except for the clock and control lock.</p> <p>The microwave oven will also turn off when the door is opened. When the door is opened, the element(s) will turn off, but the microwave oven light will remain on. Close the door and touch the START button to resume the preset cycle.</p>



	Activate Control Lock	<p>Activate Control Lock to avoid an unintended start.</p> <p>To activate, press and hold the CANCEL button for about 3 seconds until tone sounds and the CONTROL LOCKED appears on the display.</p> <p>Repeat to unlock the control panel.</p>
Options/ Clock	Set Display Auto Off	<p>This feature allows the user to set a display mode on/off. When mode is set, display will turn off after two minutes being in idle state.</p> <ol style="list-style-type: none"> 1. Press the OPTIONS/CLOCK button repeatedly until Display Auto Off. 2. Press number button 1-Yes, 2-No. 3. Press START or OPTIONS/CLOCK to save.
Options/ Clock	Set the Sound (Tones) on/off	<p>Disable or enable button tones, and set the volume level.</p> <p>Press the OPTIONS/CLOCK button repeatedly until Sound.</p> <p>Press number button 1-Button Tones, 2-Volume.</p> <p>Press START or OPTIONS/CLOCK to save.</p> <ul style="list-style-type: none"> • Button Tones: Press 1-On, 2-Off • Volume: Press 1-Low, 2-Med, 3-High
Options/ Clock	Set Scrolling Speed	<p>Scrolling speed options will be between Low, Medium and High speeds.</p> <ol style="list-style-type: none"> 1. Press the OPTIONS/CLOCK button repeatedly until Scrolling Speed. 2. Press number button 1 for Low, 2 for Medium and 3 for High. 3. Press START or OPTIONS/CLOCK to save.
Options/ Clock	Set Language	

		<p>Language of the display text may be changed.</p> <ol style="list-style-type: none"> 1. Press the OPTIONS/CLOCK button repeatedly until Language. 2. Press number button 1-English, 2-French. 3. Press START or OPTIONS/CLOCK to save.
Options/ Clock	Activate Demo Mode	<p>Demo mode shows the display and controls, without using the magnetron, thus preventing microwave functions. Press OPTIONS/CLOCK repeatedly until Demo mode, then follow the prompts to activate.</p> <p>The Clock or : will light up in the display. Repeat to deactivate.</p> <p>If the microwave oven has not been used for 5 minutes (no key press for 5 minutes), the display will show "DEMO ON".</p>
Options/ Clock	Factory Reset	<p>The microwave can be reset back to default state. To activate Factory Reset mode, at idle state, press the OPTIONS/CLOCK repeatedly until Factory Reset. Press START to reset.</p>
Power	Set Manual Cooking Time and Power	<p>Touch POWER to set manual power and cooking time. The default power level is 100%, press any number button to change the power level. For example to set the time to 2:30 in 90% power level.</p> <ol style="list-style-type: none"> 1. Touch POWER. 2. Use the number button 9 to set the power level in 90%. 3. Touch POWER again. 4. Use the number buttons to enter the cooking time length 2:30. Close the door. 5. Touch START. <p>When the stop time is reached, the microwave oven will shut off automatically, and end tones will sound.</p>
DEFROST	Automatic Defrost	

		<p>The defrost function helps thaw frozen food. To defrost, follow the instructions below:</p> <ol style="list-style-type: none"> 1. Touch DEFROST repeatedly to select food category, see DEFROST section for the food category or the door sticker on the unit. 2. Touch number button to enter the quantity. Close the door. 3. Touch START. <p>The display will count down the defrost time. For better results, a preset standing time is included in the defrosting time. This may make the defrosting time seem longer than expected.</p> <p>When the stop time is reached, the microwave oven will shut off automatically, and end tones will sound.</p>
REHEAT	Automatic Reheat	<p>To reheat using preset functions, follow the instructions below:</p> <ol style="list-style-type: none"> 1. Touch REHEAT repeatedly to select food category, see REHEAT section for the food category or the door sticker on the unit. 2. Touch number button to enter the quantity. Close the door. 3. Touch START. <p>When the stop time is reached, the microwave oven will shut off automatically, and end tones will sound.</p>
POPCORN	Popcorn	<p>To use the popcorn preset, follow the instructions below:</p> <ol style="list-style-type: none"> 1. Touch POPCORN repeatedly to select bag size. Close the door. 2. Touch START. When the stop time is reached, the microwave oven will shut off automatically, and end tones will sound
SOFTEN/ MELT	Soften/Melt	

		<p>The Soften/Melt function is used to soften or melt food. To use:</p> <ol style="list-style-type: none"> 1. Touch SOFTEN/MELT repeatedly to select food category, see SOFTEN/ MELT section for the food category or the door sticker on the unit. 2. Use the number button to enter the quantity. Close the door. 3. Press START button. <p>When the stop time is reached, the microwave oven will shut off automatically, and the end tone will sound.</p>
COOK	Auto Cook	<p>To use the auto cook presets, follow the instructions below:</p> <ol style="list-style-type: none"> 1. Press COOK repeatedly to select food category, see COOK section for the food category or the door sticker on the unit. 2. Use the number button to enter the quantity. Close the door. 3. Press START button. <p>When the stop time is reached, the microwave oven will shut off automatically, and the end tone will sound.</p>

Standby Mode

- When no functions are working, microwave oven will switch to Standby Power mode and dim the display brightness after 2 minutes. Touch any keypad or open/close the door, and the display will return to the normal brightness.

Demo Mode

- Demo mode allows user to interact with the microwave oven without turning on the magnetron. Press OPTIONS/CLOCK repeatedly until Demo Mode, then follow the prompts to activate. The Clock or : will light up in the display. Repeat to deactivate. If the microwave oven has not been used for 5 minutes (no key press for 5 minutes), the display will show "DEMO ON".

Control Lock

- The Control Lock shuts down the control panel keypads to avoid unintended use of the microwave oven. The Control Lock will remain set after a power failure, if set before the power failure occurs.
- The Control Lock is preset unlocked, but can be locked.

MICROWAVE OVEN USE

A magnetron in the microwave oven produces microwaves which reflect off the metal floor, walls, and ceiling and pass through the turntable and appropriate cookware to the food. Microwaves are attracted to and absorbed by fat, sugar, and water molecules in the food, causing them to move, producing friction and heat which cooks the food.

- To avoid damage to the microwave oven, do not lean on or allow children to swing on the microwave oven door.
- To avoid damage to the microwave oven, do not operate microwave oven when it is empty.
- The turntable must be in place and correct side up when microwave oven is in use. Do not use if turntable is chipped or broken. See the “Accessories” section to reorder.
- Baby bottles and baby food jars should not be heated in microwave oven.
- Clothes, flowers, fruit, herbs, wood, gourds, and paper, including brown paper bags and newspaper, should not be dried in the microwave oven.
- Paraffin wax will not melt in the microwave oven because it does not absorb microwaves.
- Use oven mitts or pot holders when removing containers from microwave oven.
- Do not overcook potatoes. At the end of the recommended cook time, potatoes should be slightly firm. Let potatoes stand for 5 minutes. They will finish cooking while standing.
- Do not cook or reheat whole eggs inside the shell. Steam buildup in whole eggs may cause them to burst. Cover poached eggs and allow a standing time.
- To Lock Control: Touch CANCEL for approximately 3 seconds, until two tones sound and CONTROL LOCK appears in the display. To Unlock Control: Repeat to unlock. Two tones will sound and CONTROL UNLOCK will be removed.

Food Characteristics

- When the microwave oven is cooking, the amount, size and shape, starting temperature, composition and density of the food affect cooking results.
- Amount of Food: The more food that is heated at once, the longer the cook time that is needed. Check for doneness and add small increments of time, if necessary

- **Size and Shape:** Smaller pieces of food will cook more quickly than larger pieces, and uniformly shaped foods cook more evenly than irregularly shaped food.
- **Starting Temperature:** Room temperature foods will heat faster than refrigerated foods, and refrigerated foods will heat faster than frozen foods.
- **Composition and Density:** Foods high in fat and sugar will reach a higher temperature and will heat faster than other foods. Heavy, dense foods, such as meat and potatoes, require a longer cook time than the same size of a light, porous food, such as cake.

Cooking Guidelines Covering

- **Covering food** helps retain moisture, shorten cook time, and reduce spattering. Use the lid supplied with cookware. If a lid is not available, wax paper, paper towels, or plastic wrap approved for microwave ovens may be used. Plastic wrap should be turned back at one corner to provide an opening to vent steam. Condensation on the door and cavity surfaces is normal during heavy cooking.
- **Stirring and Turning:** Stirring and turning redistributes heat evenly to avoid overcooking the outer edges of food. Stir from outside to center. If possible, turn food over from bottom to top.
- **Arranging:** If heating irregularly shaped or different-sized foods, arrange the thinner parts and smaller-sized items toward the center. If cooking several items of the same size and shape, place them in a ring pattern, leaving the center of the ring empty.
- **Piercing:** Before heating, use a fork or small knife to pierce or prick foods that have a skin or membrane, such as potatoes, egg yolks, chicken livers, hot dogs, and sausage. Prick in several places to allow steam to vent.
- **Shielding:** Use small, flat pieces of aluminum foil to shield the thin pieces of irregularly shaped foods, bones, and foods such as chicken wings, leg tips, and fish tails. See the “Aluminum Foil and Metal” section first.
- **Standing Time:** Food will continue to cook by the natural conduction of heat, even after the microwave cooking cycle ends. The length of standing time depends on the volume and density of the food.

Cookware and Dinnerware

Cookware and dinnerware must fit on the turntable. Always use oven mitts or pot holders when handling because any dish may become hot from heat transferred from the food. Do not use cookware and dinnerware with gold or silver trim. Use the following chart as a guide, then test before using.

Material	Recommendations
Aluminum Foil, Metal	See the “Aluminum Foil and Metal” section.
Browning Dish	Bottom must be at least 3/16" (5 mm) above the turntable. Follow manufacturer’s recommendations.
Ceramic Glass, Glass	Acceptable for use.
China, Earthenware	Follow manufacturer’s recommendations.
Melamine	Follow manufacturer’s recommendations.
Paper: Towels, Dinnerware, Napkins	Use non-recycled and those approved by the manufacturer for microwave oven use.
Plastic: Wraps, Bags, Covers, Dinnerware, Containers	Use those approved by the manufacturer for microwave oven use
Pottery and Clay	Follow manufacturer’s recommendations.
Silicone Bakeware	Follow manufacturer’s recommendations.
Straw, Wicker, Wooden Containers	Do not use in microwave oven.
Styrofoam®†	Do not use in microwave oven.
Wax Paper	Acceptable for use.

To Test Cookware or Dinnerware for Microwave Use:

1. Place cookware or dinnerware in microwave oven with 1 cup (250 mL) of water beside it.
2. Cook at 100% cooking power for 1 minute.

Do not use cookware or dinnerware if it becomes hot and the water stays cool.

Aluminum Foil and Metal

Always use oven mitts or pot holders when removing dishes from the microwave oven.

Aluminum foil and some metal can be used in the microwave oven. If not used properly, arcing (a blue flash of light) can occur and cause damage to the microwave oven.

OK for Use

Racks and bakeware supplied with the microwave oven (on some models), aluminum foil for shielding, and approved meat thermometers may be used with the following guidelines:

- To avoid damage to the microwave oven, do not allow aluminum foil or metal to touch the inside cavity walls, ceiling, or floor.
- Always use the turntable.
- To avoid damage to the microwave oven, do not allow contact with another metal object during microwave cooking

Do Not Use

- Metal cookware and bakeware, gold, silver, pewter, non-approved meat thermometers, skewers, twist ties, foil liners, such as sandwich wrappers, staples, and objects with gold or silver trim or a metallic glaze, should not be used in the microwave oven.
- Metal bakeware may be used only during convection (bake) cycles. Use ovenproof, microwave-safe cookware for all other convection and combination.

†Styrofoam® is a registered trademark of The Dow Chemical Company.

Microwave Cooking Power

Many recipes for microwave cooking specify which cooking power to use by percent, name, or number. For example, 70%=Medium-High=7.

Use the following chart as a general guide for the suggested cooking power of specific foods.

MICROWAVE COOKING POWER CHART

Percent/ Name	Number	Use
100%, High (default setting)	10	Quick-heating convenience foods and foods with high water content, such as soups, beverages, and most vegetables.
90%	9	Cooking small, tender pieces of meat, ground meat, poultry pieces, and fish fillets. Heating cream soups.
80%	8	Heating rice, pasta, or casseroles. Cooking and heating foods that need a cook power lower than high, for example, whole fish and meat loaf.
70%, MediumHigh	7	Reheating a single serving of food.
60%	6	Cooking sensitive foods such as cheese and egg dishes, pudding, and custards. Cooking non-stirtable casseroles, such as lasagna.
50%, Medium	5	Cooking ham, whole poultry, and pot roasts. Simmering stews
40%	4	Melting chocolate. Heating bread, rolls, and pastries
30%, MediumLow, Defrost	3	Defrosting bread, fish, meats, poultry, and precooked foods.
20%	2	Softening butter, cheese, and ice cream.
10%, Low	1	Taking chill out of fruit

Sensor Cooking

A sensor in the microwave oven detects humidity released from the food as it heats, and adjusts the cook time accordingly. Many sensor cycles require the covering of foods. Microwave safe containers or steamers with loose-fitting lids are recommended. The loose-fitting lid allows enough steam to escape to be detected by the sensor. When covering foods with plastic wrap, be sure to leave a large enough vent opening to allow the steam to escape.

NOTE:

- The microwave oven should be plugged in for at least 3 minutes.
- The microwave oven cavity and the exterior of the cooking container should be dry.
- The room temperature should not exceed 95° (35°C).
- If the door is opened during a sensor cycle, sensing will stop and the program will be canceled.

Popcorn

Two choices, press Popcorn repeatedly. Small bag: 1.75 oz (50 g) only Large bag: Senses 3.0-3.5 oz (85-99 g)

- Do not use regular paper bags or glassware.
- Pop only one package of popcorn at a time.
- Follow manufacturer's instructions when using a microwave popcorn popper.
- Listen for popping to slow to one pop every 1 or 2 seconds, and then stop the cycle. Do not repop unpopped kernels.
- For best results, use fresh bags of popcorn.
- Cooking results may vary by brand and fat content.

NOTE: Follow the instructions provided by the microwave popcorn manufacturer.

Reheat

Times and cooking powers have been preset for reheating a number of food types.

Use the following chart as a guide.

REHEAT CHART

Item	Food Category	Quantity
1	<p>Baked Goods</p> <p>Place on paper towel. Two small rolls may be counted as 1 serving</p>	1, 2, 3, 4, 5 or 6 servings
2	<p>Beverage</p> <p>Do not cover</p>	1-2 cups (250 mL-500 mL)
3	<p>Casserole</p> <p>Place in microwave-safe container. Cover with plastic wrap and vent. Stir and let stand 2-3 minutes after reheating.</p>	1-4 cups (250 mL-1 L)
4	<p>Dinner plate</p> <p>Place food on plate. Cover with plastic wrap and vent. Let stand 2-3 minutes after reheating.</p>	Senses 1 plate, about 8-16 oz (227-454 g)
5	<p>Pizza</p> <p>Place on paper towel lined microwave-safe plate.</p>	1-3 slice, 4 oz (113 g) each 6 Sauce Place in microwave-safe container. Cover with plastic wrap and vent. Stir and let stand 2-3 minutes after reheating. Senses 1
6	<p>Sauce</p> <p>Place in microwave-safe container. Cover with plastic wrap and vent. Stir and let stand 2-3 minutes after reheating.</p>	Senses 1-4 cups (250 mL-1 L)
7	<p>Soup</p> <p>Place in microwave-safe container. Cover with plastic</p>	Senses 1-4 cups (250 mL-1 L)

wrap and vent. Stir and let stand 2-3 minutes after reheating.
--

Soften/Melt

Soften and Melt functions may be used to soften or melt your food. Times and cooking powers have been preset for a number of food types. Use the following chart as a guide.

Item	Food Category	Quantity	Preparation
1	Soften Butter	0.5, 1.0, 1.5, 2.0 sticks	Unwrap and place in microwave-safe container.
2	Soften Ice Cream	16, 32, or 64 oz (473, 946 or 1893 mL)	Place ice cream container on turntable.
3	Soften Cream Cheese	8 oz (227 g)	Unwrap and place in microwave-safe container.
4	Soften Frozen Juice	12 oz (340 g)	Remove lid.
5	Melt Butter	0.5, 1.0, 1.5, 2.0 sticks	Unwrap and place in microwave-safe container.
6	Melt Chocolate	4, 6, 8 or 12 oz (113, 170, 227 or 340 g)	Cut squares into small pieces or use chips. Place in microwavesafe container.
7	Melt Cheese	8 or 16 oz (227 or 454 g)	Cut into small pieces and place in microwavesafe container.
8	Melt Marshmallows	5 or 10 oz (142 or 283 g)	Place in microwave-safe container.

Defrost

- For optimal results, food should be 0°F (-18°C) or colder when defrosting.
- Unwrap foods and remove lids (from fruit juice) before defrosting.
- Shallow packages will defrost more quickly than deep blocks.
- Separate food pieces as soon as possible during or at the end of the cycle for more even defrosting.

- Foods left outside the freezer for more than 20 minutes or frozen ready-made food should not be defrosted using the Defrost feature but should be defrosted manually.
- Use small pieces of aluminum foil to shield parts of food such as chicken wings, leg tips, and fish tails. See the “Aluminum Foil and Metal” section first
- Times and cooking powers have been preset for defrosting a number of food types.

Item	Food Category	Weight
1	Poultry*	0.2 to 6.6 lbs (90 g to 3 kg)
2	Meat*	0.2 to 6.6 lbs (90 g to 3 kg)
3	Fish*	0.2 to 4.4 lbs (90 g to 2 kg)
4	Quick Defrost	1.0 lb only (454 g)

* See the Defrost Preparation Chart at end of the “Defrost” section for cuts, sizes, and instructions. Use the following chart as a guide when defrosting meat, poultry, or fish.

MICROWAVE OVEN CARE

General Cleaning

IMPORTANT: Before cleaning, make sure all controls are off and the microwave oven is cool. Always follow label instructions on cleaning products.

Soap, water, and a soft cloth or sponge are suggested first, unless otherwise noted.

STAINLESS STEEL (on some models)

- **NOTE:** To avoid damage to stainless steel surfaces, do not use soap-filled scouring pads, abrasive cleaners, cooktop polishing creme, steel-wool pads, gritty washcloths, or abrasive paper towels. Damage may occur to stainless steel surfaces, even with one-time or limited use.
- Rub in direction of grain to avoid damaging.
- Cleaning Method:
 - Affresh® Stainless Steel Cleaners (not included): See the “Accessories” section.
 - Vinegar for hard water spots

MICROWAVE OVEN DOOR EXTERIOR

- Cleaning Method:
 - Glass cleaner and a soft cloth or sponge: Apply glass cleaner to soft cloth or sponge, not directly on panel.

MICROWAVE OVEN CAVITY

- To avoid damage to microwave oven cavity, do not use soapfilled scouring pads, abrasive cleaners, steel-wool pads, gritty washcloths, or some paper towels.
- On stainless steel models, rub in direction of grain to avoid damaging.
- The area where the microwave oven door and frame touch when closed should be kept clean
- Cleaning Method:
 - Average soil: Mild, nonabrasive soaps and detergents: Rinse with clean water and dry with soft, lint-free cloth.
 - Heavy soil: Mild, nonabrasive soaps and detergents: Heat 1 cup (250 mL) of water for 2 to 5 minutes in microwave oven. Steam will soften soil. Rinse with clean water and dry with soft, lint-free cloth.
 - Odors: Lemon juice or vinegar: Heat 1 cup (250 mL) of water with 1 tbs (15 mL) of either lemon juice or vinegar for 2 to 5 minutes in microwave oven.

TURNTABLE

- Replace turntable immediately after cleaning. Do not operate the microwave oven without the turntable in place.
- Cleaning Method:
 - Mild soap and water
 - Dishwasher

TURNTABLE SUPPORT AND ROLLERS, HUB

- Mild soap and water or dishwasher

NONSTICK CAVITY COATING (on some models)

- To avoid damage to the microwave oven cavity, do not use metal or sharp utensils or scrapers or any type of abrasive cleanser or scrubbers.

Replacing The Cavity Light

Cavity Light is located at the top front of the microwave oven, under the cover and is replaceable.

To replace the cavity light refer the following steps.

1. Use a Phillips head screwdriver to remove the 4 wood screws securing the trim kit frame to the cabinet.

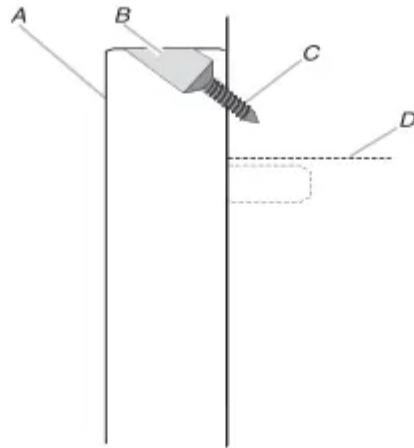

- A. Trim kit frame*
- B. Mounting hole guide*
- C. #7-16x15/16" flat head wood screw (4)*
- D. Cutout ceiling*

WARNING - Excessive Weight Hazard: Use two or more people to move and install air conditioner. Failure to do so can result in back or other injury.

2. Using 2 people, slide the microwave oven out of the cabinet. Unplug the microwave oven and place on a stable surface with the microwave door and frame sitting slightly beyond the edge of the surface

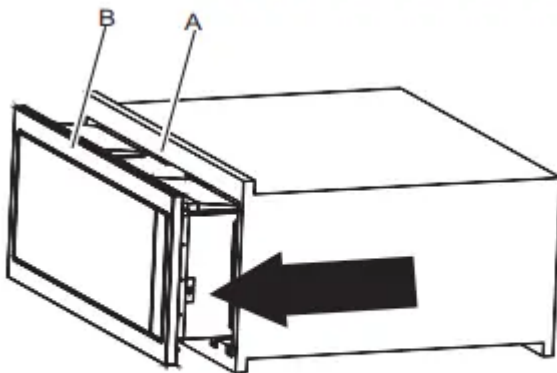

- A. Cabinet*
- B. Microwave Oven*

3. Remove the 3 short screws to release the leftside cooling duct, see below pictorial. Set screws and cooling duct aside.

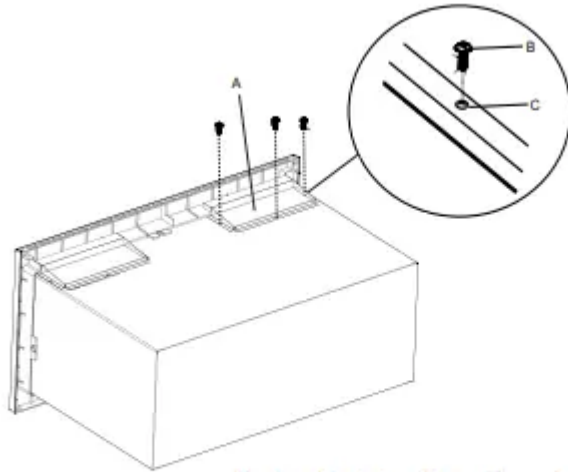

- A. Leftside Cooling Duct*
- B. Short Screws (3)*
- C. Screw holes (3)*

4. Remove the 4 screws which fasten the trim kit frame to the microwave oven, and set the 4 screws aside.

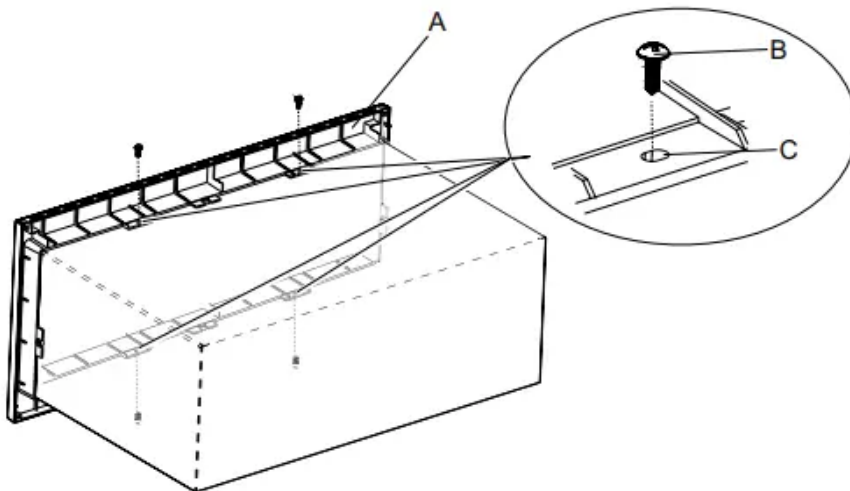

- A. Trim Kit Frame*
- B. #7-18x7/16" round head sheet metal screw (4)*
- C. Screw holes (4)*

5. Pull the Trim Kit Frame away from the front of the microwave to release it. Note the 'TOP' and 'up arrow' molded into the frame, the 4 locating pins and the locating slots, set frame aside.

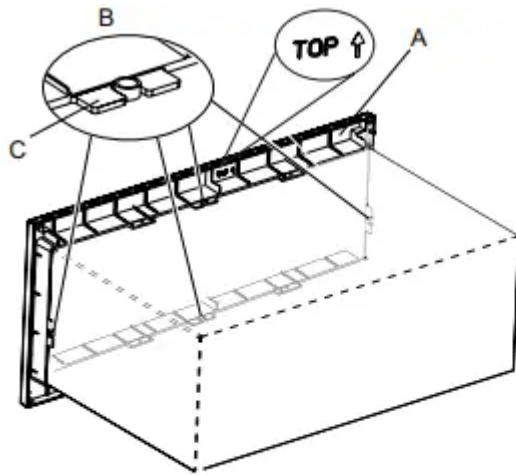

- A. Trim Kit Frame
- B. Locating pin (4)
- C. Locating slot (4)

6. Remove the light cover screw from the top front of the microwave oven.

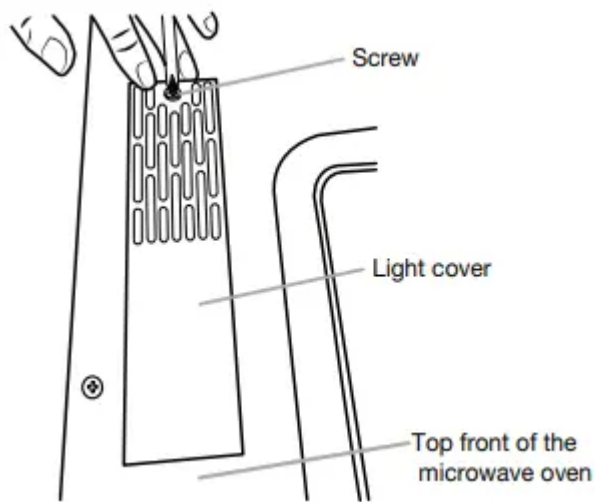

7. Remove the light cover.

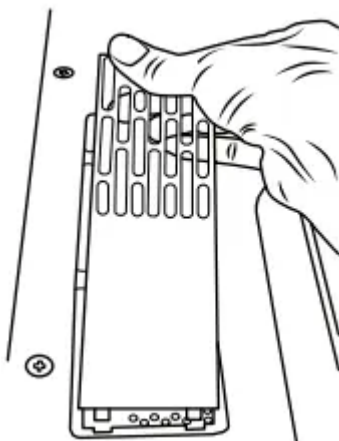

8. Disengage hook to remove LED board.

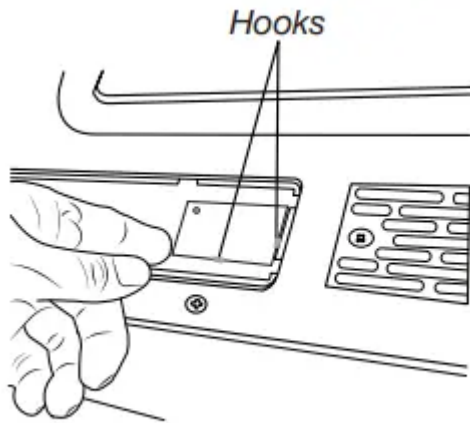

9. Unplug the LED terminal

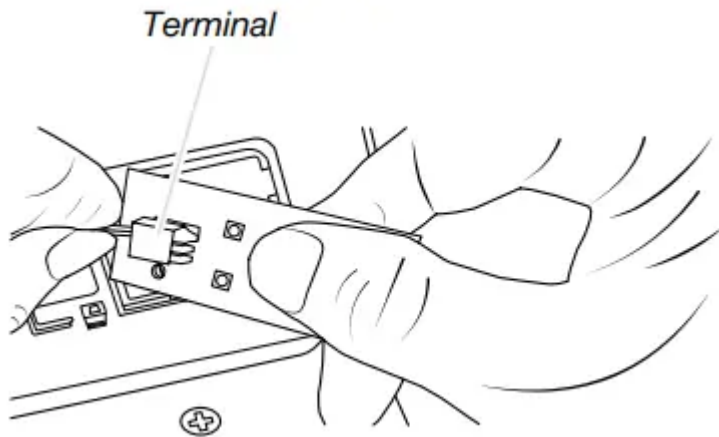

10. Connect replacement LED to terminal and snap it into place, securing with the hook.

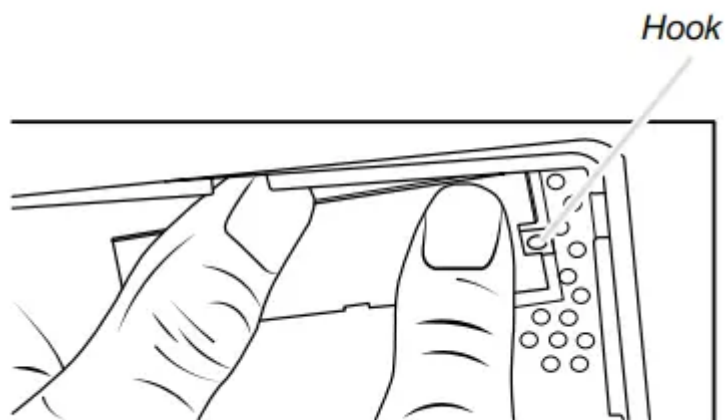

11. Plug in the LED terminal removed in step 9.



12. Reattach the LED board removed in step 8.
13. Reattach the Light cover removed in step 7.
14. Reattach the light cover screw removed in step 6.
15. Reattach the trim kit frame that was removed in step 5, to the microwave oven by first aligning the 4 locating slots with the locating pins.
16. Use the 4 screws removed in step 4, to fasten the trim kit frame to the microwave oven.
17. Use the 3 screws removed in step 3 to reattach the leftside cooling duct.

WARNING: Electrical Shock Hazard - Plug into a grounded 3 prong outlet. Do not remove ground prong. Do not use an adapter. Do not use an extension cord. Failure to follow these instructions can result in death, fire, or electrical shock.

18. Slide the microwave oven back to the cabinet. Plug in the microwave oven.
19. Reattach the trim kit frame and microwave to the cabinet using the screws removed in step 1.

TROUBLESHOOTING



If you experience	Recommended Solutions
Microwave oven will not operate	<p>Check the following:</p> <ul style="list-style-type: none"> • Household fuse or circuit breaker: If a household fuse has blown or a circuit breaker has tripped, replace the fuse or reset the circuit breaker. If the problem continues, call an electrician. • Magnetron: Try to heat 1 cup (250 mL) of cold water for 2 minutes at 100% cooking power. If water does not heat, try the steps in the bullets below. If microwave oven still does not operate, call for service. • Door: Firmly close door. On some models, if a packaging spacer is attached to inside of the door, remove it, then firmly close door. If a message about the door appears in the display, the door has been closed for 5 minutes or more without the microwave oven being started. This occurs to avoid unintended starting of the microwave oven. Open and close the door, then start the cycle. • Control: Make sure control is set properly. Make sure Control Lock is off. Make sure Demo mode (on some models) is off.
Arcing in the microwave oven	<p>Check the following:</p> <ul style="list-style-type: none"> • Soil buildup: Soil buildup on cavity walls, microwave inlet cover, cooking rack supports, and area where the door touches the frame can cause arcing. See “General Cleaning” in the “Microwave Oven Care” section.
Turntable alternates rotation directions	<ul style="list-style-type: none"> • This is normal and depends on motor rotation at the beginning of the cycle.
Display shows messages	<ul style="list-style-type: none"> • “Enter Clock” with flashing digits means there has been a power failure. Reset the clock.



	<ul style="list-style-type: none"> • A letter followed by a number is an error indicator. Call for assistance.
Radio, TV, or cordless phone interference	<p>Check the following:</p> <ul style="list-style-type: none"> • Proximity: Move the receiver away from the microwave oven, or adjust the radio or TV antenna. • Soil: Make sure the microwave oven door and sealing surfaces are clean. • Frequency: Some 2.4 GHz-based cordless phones and home wireless networks may experience static or noise while microwave oven is on. Use a corded phone, a different frequency cordless phone, or avoid using these items during microwave oven operation.
Moisture in the microwave cavity and/or on the exterior glass	<p>Check the following:</p> <ul style="list-style-type: none"> • During microwave cycles that release significant moisture from the item being cooked (i.e. potatoes), it is normal to see and feel moisture in the microwave cavity and/or on the exterior glass as this moisture is vented from the unit. This moisture should not impact any surrounding surface. Wipe away with towel.

Warning

This content is compiled from multiple sources and is provided for reference purposes only. It may not be complete or fully applicable to all situations. If you are unable to resolve your issue, please contact the product manufacturer or an authorized service provider for official support.