

## Refrigerator at a glance

The actual image and provided component parts of the refrigerator may differ, depending on the model and the country.

For more information, see the Layout section.

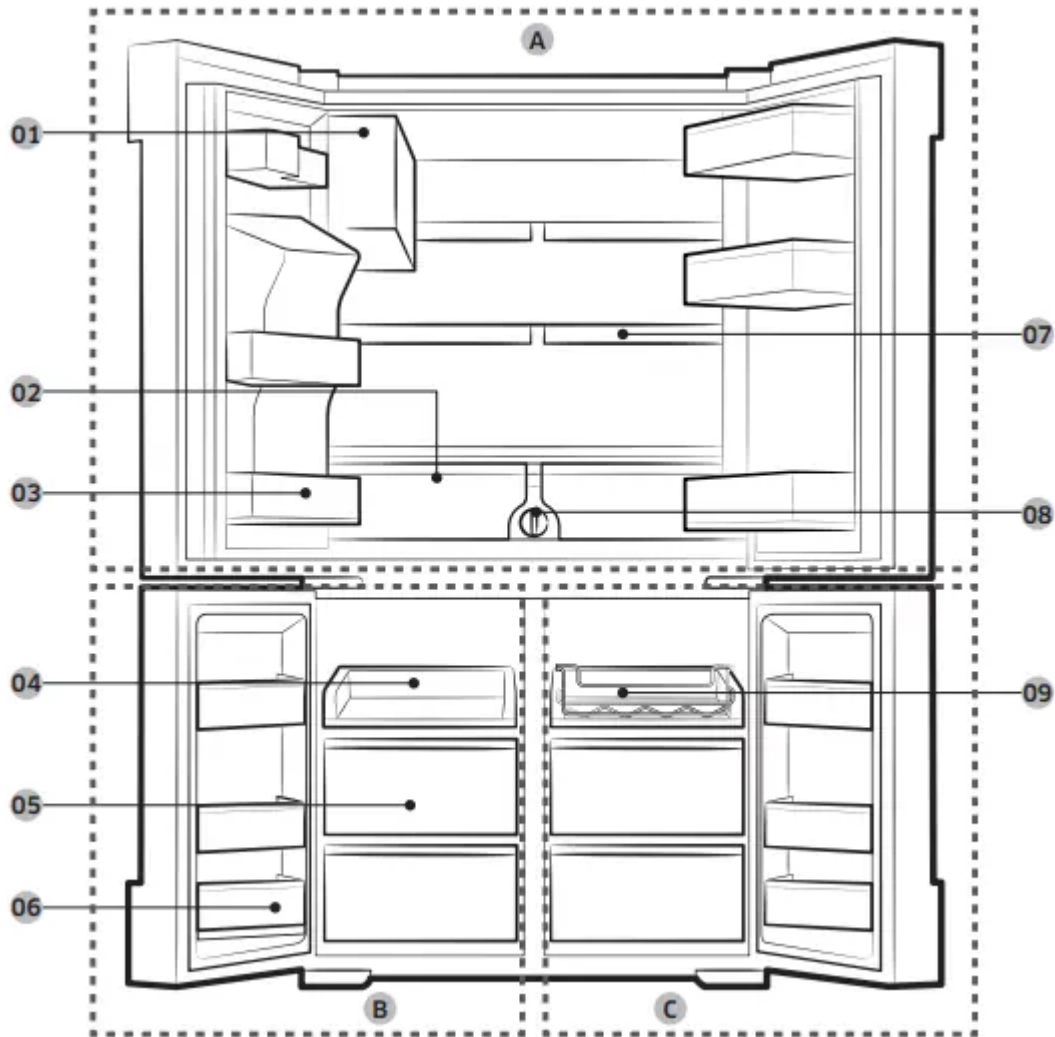

1. Auto Ice Maker (Ice Master)
2. EZ Fresh Vegetable & Fruit Drawers
3. Fridge Multi-Purpose Guard
4. Easy Slide-Shelf
5. Dry Food and Meat Storage Drawers
6. Freezer door Bins
7. Quick Space Shelf
8. Water filter
9. Wine Rack

- A. Fridge
- B. Freezer
- C. Cool Select+ (FlexZone)

**NOTE:**

- For best energy efficiency, make sure all shelves, drawers, and bins are placed in their original position.
- When closing the door, make sure the vertical hinged section is in the correct position to avoid scratching the other door.
- If the vertical hinged section is reversed, put it back into the correct position, and then close the door.
- Moisture may form at times on the vertical hinged section.
- If you close a door by force, the other door may open.
- When the door opens, the interlock switch automatically disables the auger motor of the ice maker for safety reasons.
- If the internal or external LED lamp is out of order, contact a local Samsung service center.

## Operations

### User interface

**NOTE:**

- For more information about other menus and apps available on the Refrigerator app, see the Online manual of your refrigerator.
- The content of apps and widgets, or their design is subject to change or support may be discontinued without notice, depending on the content provider's policy.
- Children's use of the refrigerator's functions, apps, and services must be supervised by adults.
- Underage transactions with the services must be supervised by adults.

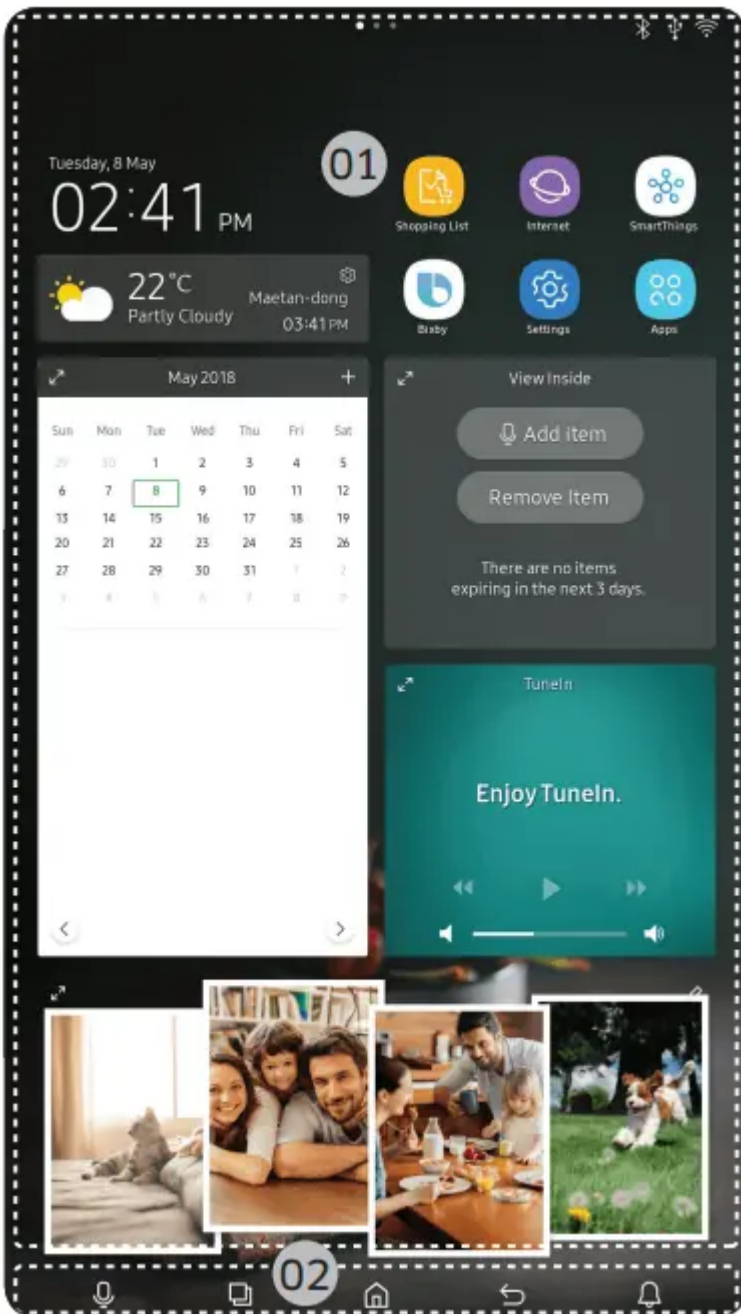

01. Home screen

02. Soft buttons

01. Home screen

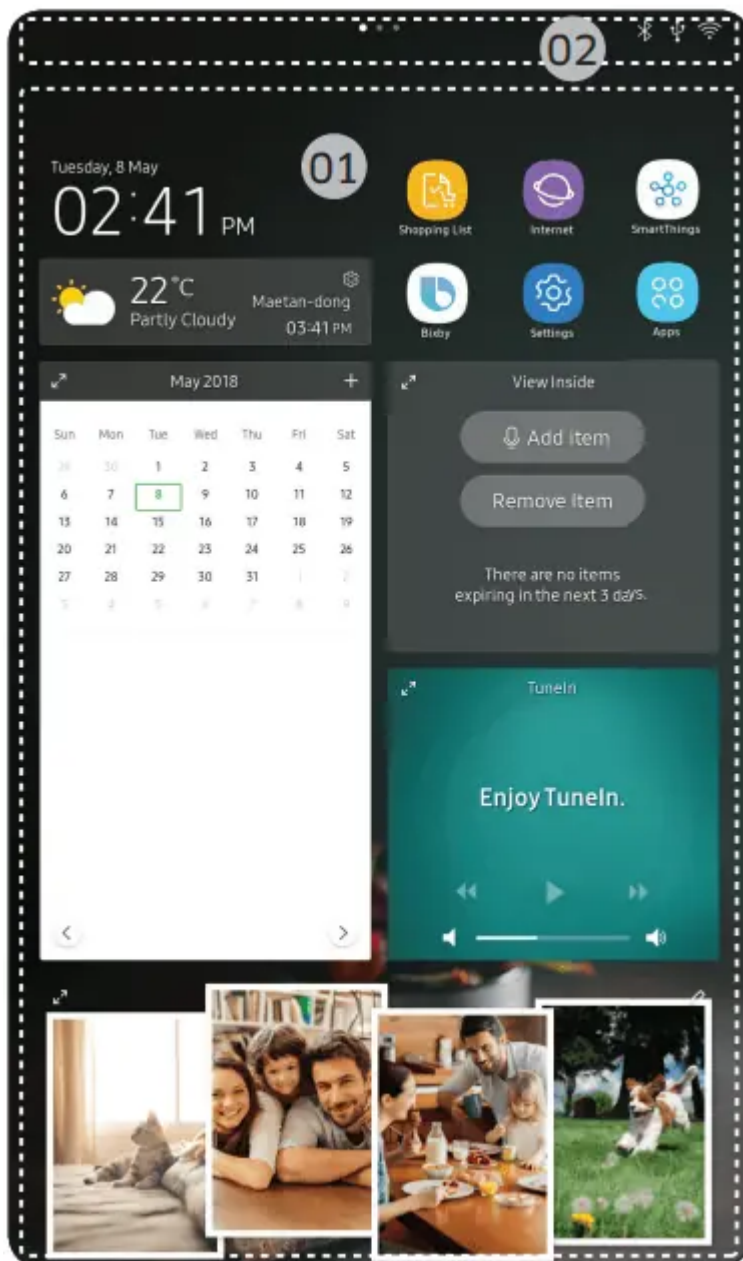







## 01. Apps & Widgets

- Tap a desired app or widget to launch it.
- Tap and hold an app or widget to enter Edit mode. A grid appears. In Edit mode, you can drag and drop an app or widget to a new position on the grid. When you move the app or widget to a new grid location, the location turns blue if it is available. If it is not available, it turns red.
- You can add an app or widget that has been removed from the Apps list.

## 02. Status bar

- Displays the status of various functions. (Refer to the following Icon descriptions table.)

## Icon descriptions

Bluetooth (  )	Indicates Bluetooth connection status
USB (  )	Indicates USB connection status.  NOTE: The refrigerator supports USB memory that is formatted in the FAT32 or exFAT file systems. NTFS is not supported. Be sure to convert NTFS to FAT32 or exFAT before use.
Remote Management (  )	Turns on when Remote Management is enabled and running.
Network (  )	Indicates network connection status in 5 levels (Off, 1-4).
Software Update (  )	Indicates the newest version of software has been downloaded from the server and is ready to update.
Notification (  )	Indicates there is a notification message.
Cloud sync (  )	Indicates Family Hub is receiving data from the cloud server.

## 02 Soft buttons

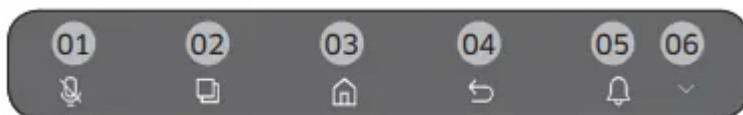

### 01. Microphone

- Tap to turn on or turn off the microphone function.
- The microphone icon turns red when it is turned off.

### 02. Task Manager

- Tap to open the Task Manager.
- See the Task Manager section for details.

### 03. Home

- Tap to open the Home screen.

### 04. Return

- Tap to return to the previous screen.

### 05. Notification

- Tap to display the Quick Panel.

#### 06. Hide/Show

- Tap to hide or show Soft buttons.

- The Hide/Show button only appears when an app is active.

### Fridge Manager

To access Fridge Manager, swipe the Home screen to the left, and then tap the Fridge Manager widget.

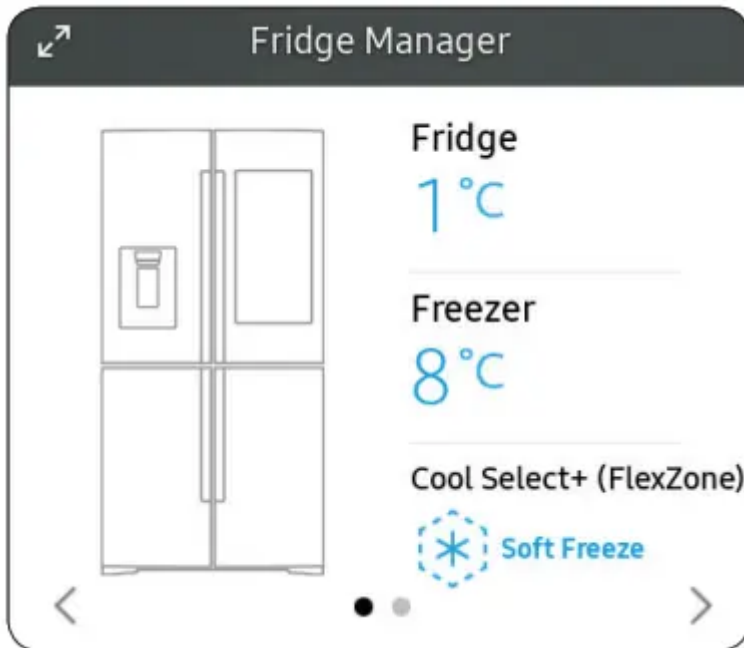

- Tap < or > on the bottom of the widget to move between pages.
- On the first page, you can check the current temperatures or modes of each compartment as well as active special functions.
- Tap the first page to open the Fridge Manager for detailed settings.
- On the second page, you can check the filter status.
- Tap the second page to open the Fridge Settings.

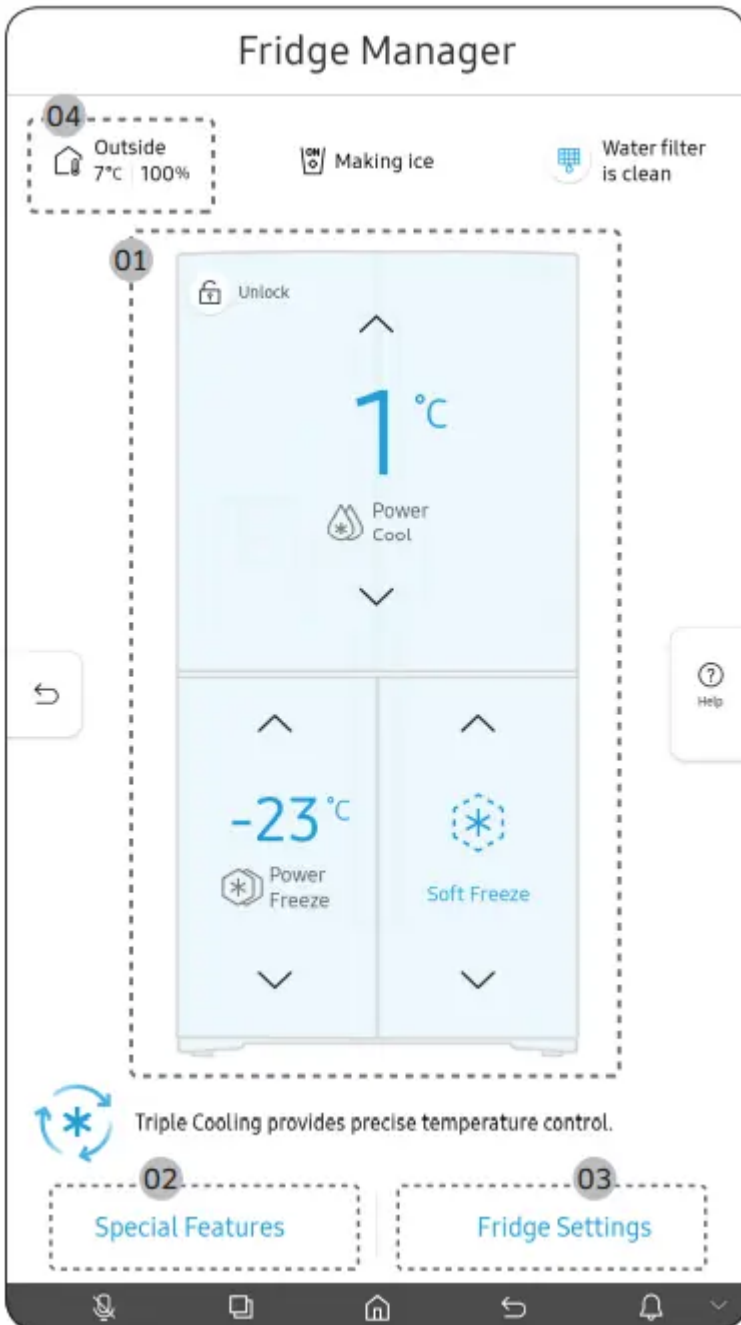

The Fridge Manager is a graphical representation of your refrigerator. The top half represents the refrigerator compartment, the bottom left the freezer compartment, and the bottom right the Cool Select+. The temperature or mode settings for each are displayed over each section.

### Fridge Manager At a Glance

#### 01. Temperature

Set or change the temperatures for the fridge, freezer, and Cool Select+ with Power mode (Power Cool or Power Freeze).

- Power Cool and Power Freeze speeds up the cooling and freezing process at maximum fan speed. The fridge and the freezer keeps running at full speed for several hours, and then returns to the previous temperature.

- To freeze large amounts of food, activate Power Freeze for at least 20 hours before putting food in the freezer.

**NOTE:** Using Power Cool or Power Freeze increases power consumption. Make sure you turn it off to return to the previous temperature if you do not intend to use it.

## 02. Special Features

Special functions available on this refrigerator are listed with a brief description.

## 03. Fridge Settings.

See the next section for details.

## 04. External Conditions

Displays the external (ambient) temperature and humidity.

**NOTE:** The displayed conditions may differ from the actual temperature and humidity.

**NOTE:** Also displayed is the Ice Maker off indicator at the top, center. When the indicator displays Ice Maker off, the refrigerator's ice maker is turned off.

Ice Maker	Turns the icemaker on and off. Tap and drag the button to turn on or off. Note that if the ice bucket is full of ice, the refrigerator does not start making ice when you turn on the icemaker, but displays the Ice Full indicator on the main screen. If you hold down the dispenser lever for 5 seconds, the Ice Maker Off status changes to Making ice.
Dispenser Lock	Turn the Dispenser Lock on or off.
Door Alarm	With the Door Alarm enabled, the door being open displays an alert with a beep. With the Door Alarm disabled, the door being open displays just an alert.
Temp. Unit	Switch the scale unit between Celsius and Fahrenheit
Water Filter	Provides a water filter replacement tutorial and lets you reset the water filter replacement indicator. Tap to open. <b>NOTE:</b> After installing the water filter, tap Water Filter, and then tap Reset. Tapping Reset re-initializes the function that measures the time remaining until the water filter needs to be replaced again.
Self Check	Self Check is a self diagnoses function. Tap to open. Tap Start to run.

## Settings

Display	You can set the screen brightness, wallpapers, auto wake-up, motion detector, theme, screen timeout, and duration of the screen saver.
Sou	Set the volume and equalizer and turn on or turn off the touch sound.
Wi-Fi	Turn on or turn off a Wi-Fi connection. The current Wi-Fi network is listed first in the access point (AP) list.
Bluetooth	<p>When the Speaker mode is on, you can listen to music and media on your mobile phone or tablet through Family Hub's speaker.</p> <ul style="list-style-type: none"> <li>- Only one connected mobile phone or tablet is listed.</li> </ul> <p>When the Speaker mode is off, you can search and connect to nearby Bluetooth-enabled devices.</p> <ul style="list-style-type: none"> <li>- Up to 4 recently paired Bluetooth devices are listed.</li> <li>- To add a new device when 4 paired devices are listed, first unpair a paired device from the device list.</li> <li>- Available devices are Bluetooth-enabled headsets, headphones, and speakers.</li> </ul>
Voice	You can check the Voice function language, turn on or turn off Voice wake-up, select Wake Word, register and manage Voice ID, and check information about Bixby.
Profile	You can add, edit, or delete a profile.
Security	Enable or disable restrictions on Family Hub features and apps.
Language	Select a preferred language. Available languages depend on the sales region.
Date and Time	<p>Make sure the Automatic date and time function is on with a proper Wi-Fi network connection. Open the fridge door and locate the display reset button on the inner side of the door. Press the button and press again to reset the display. Then, the date and time will be synced by the time server.</p> <p>You can change the time zone through the Time zone menu.</p>
About Device	

	<p>Make sure the Software Update function is on with a proper Wi-Fi network connection.</p> <p>When updates are available, the Update button becomes active. When updates are complete, the refrigerator restarts automatically.</p> <p>Legal information displays the Open Source License Agreement. Tap the list item to open the Open Source Announcement.</p>
Easy Connection	<p>Easy Connection can be used with Samsung Smartphone apps, and allows you to connect your device to the same home Wi-Fi network that your smartphone is connected to.</p>
Clean Screen Mode	<p>Turn on so you can clean the screen without activating any apps.</p>
Online Manual	<p>The online manual will walk you through various menus and apps that the refrigerator provides directly on the display.</p>
Factory Data Reset	<p>Tap Reset to restart the refrigerator in Factory Data Reset mode. All user data will be removed permanently. Data that will be removed includes account information, memos, photos, and user settings.</p> <p><b>CAUTION:</b> Once factory reset is complete, no user data can be recovered.</p>
Remote Management	<p>Use Remote Management to allow a service representative to remotely diagnose problems and provide solutions.</p> <p>Remote Management requires a Wi-Fi connection.</p> <p>The Remote Management menu does not appear on models that do not support Remote Management</p>

### Display reset (applicable models only)

If you encounter an abnormal symptom on the display, try resetting the display. This may solve the symptom.

1. Open the right-side fridge door and locate the switch cover on the top right corner of the door.

2. Push up the cover to reveal the power switch

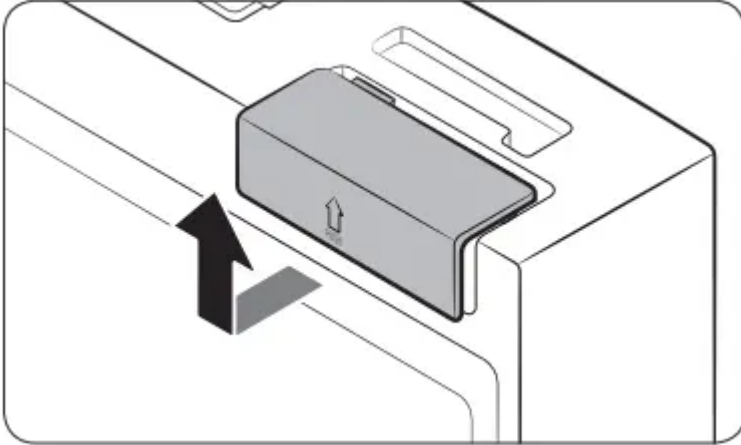

3. Turn the switch off and turn it on again.

4. Reinsert the switch cover to the end until you hear a clicking sound.

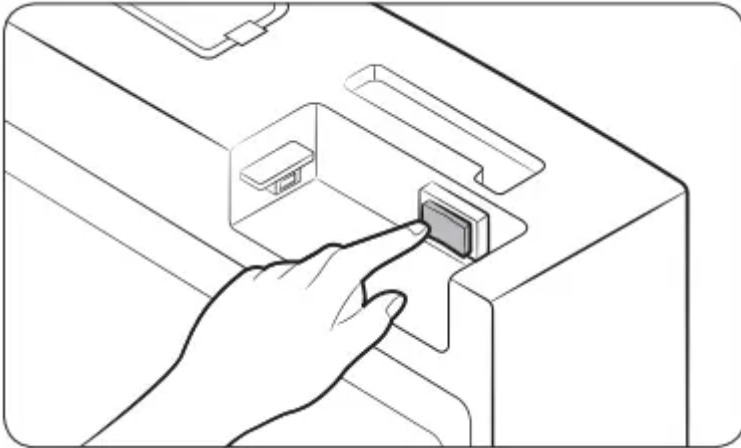

## SmartThings

### Installation

Visit the Google Play Store, Galaxy Apps, or Apple App Store and search for “SmartThings”. Download and install the SmartThings app provided by Samsung Electronics to your smart device.

#### NOTE:

- The SmartThings app is designed for Android 6.0 (Marshmallow) or later, iOS 10.0 or later, iPhone 6 or later, and is optimized for Samsung smartphones (Galaxy S and Galaxy Note series).
- For improved performance, the SmartThings app is subject to change without notice, or discontinued support according to the manufacturer’s policy.
- Recommended encryption systems include WPA/TKIP and WPA2/AES. Any newer or unstandardized Wi-Fi authentication protocols are not supported.
- Wireless networks may be affected by the surrounding wireless communication environment.

- If your Internet service provider has registered the MAC address of your PC or modem for identification, your Samsung Smart Refrigerator may fail to connect to the Internet. If this happens, contact your Internet service provider for technical assistance.
- The firewall settings of your network system may prevent your Samsung Smart Refrigerator from accessing the Internet. Contact your Internet service provider for technical assistance. If this symptom continues, contact a local Samsung service center or retailer.
- To configure the wireless access point (AP) settings, see the user manual of the AP.
- Samsung Smart Refrigerators support both Wi-Fi 2.4 GHz with IEEE 802.11 b/g/n and Soft-AP protocols (IEEE 802.11 n is recommended).
- Unauthorized Wi-Fi wireless routers may fail to connect to applicable Samsung Smart Refrigerators.

### Samsung account

You are required to register your Samsung account to use the app. If you don't have a Samsung account, follow the app's onscreen instructions to create a free Samsung account.

### Getting started

Turn on the device you want to connect, open the SmartThings app on your phone, then follow the instructions below.

If a pop-up appears saying that a new device has been found, tap ADD NOW.

If a pop-up doesn't appear, tap the + button, then select the device you want to connect from the list of available devices.

If your device isn't in the list of available devices, tap Supported Devices, select the device type (Refrigerator), and then select the specific device model.

Follow the instructions in the app to set up your device. Once setup is complete, your refrigerator will appear as a "card" on your Devices screen.

### Refrigerator app

#### Integrated control

You can monitor and control your refrigerator at home and on the go.

- Tap the refrigerator icon on the SmartThings Dashboard or tap the Devices icon at the bottom of the Dashboard, and then tap the refrigerator "card" to open the Refrigerator page.
- Check the operation status or notifications related to your refrigerator, and change options or settings if necessary.

**NOTE:** Some options or settings of the refrigerator may not be available for remote control.

Category	Item	Description
Monitoring	Fridge temperature	Displays the desired temperature setting of the fridge.
	Freezer temperature	Displays the desired temperature setting of the freezer
	Cool Select+ (FlexZone) settings	Displays the settings of the Cool Select+ (FlexZone).
	Self Check	Detects abnormal operations of the refrigerator.
	Energy monitoring	Checks the accumulated power consumption of the refrigerator for the last 180 days.
Functions	Ice making	You can turn the ice making function on or off, and check the current settings of the function.
		You can also check the status and progress of ice making.
	Power Cool	You can turn Power Cool on or off, and check the current settings.
	Power Freeze	You can turn Power Freeze on or off, and check the current settings.
Alarms	Abnormally high temperature	This alarm is triggered when the fridge, the freezer, or the Cool Select+ (FlexZone) has abnormally high temperatures.
	Door opening	This alarm is triggered if the fridge or freezer door or the Cool Select+ (FlexZone) door is left open for a specific time.
	Water filter replacement	This alarm reminds you that the water filter must be replaced.
Inside Image		You can view the inside of the refrigerator and can see if you need to replace food items.
Family Hub App Link		You can connect to the App Store and download the Refrigerator app.

## Recommendations for voice recognition

For the voice recognition function, there is a built-in microphone at the top of the refrigerator's display. To use the voice recognition function:

- Stand no more than 1 meter from the refrigerator and speak loudly and clearly towards the built-in microphone.
- Speak at a regular pace. Reduce ambient noises, such as noises from a living-room TV.

**NOTE:** The voice recognition function may not work if you stand more than 1 meter away or if you speak too softly.

## Samsung Family Hub

### Installation

Visit the Google Play Store, Galaxy Apps, or Apple App Store and search for "Samsung Family Hub". Download and install the Samsung Family Hub app provided by Samsung Electronics to your smart device.

### NOTE:

- The Samsung Family Hub app is designed for Android 4.4 (KitKat) or higher, or iOS 8.0 or higher, and is optimized for Samsung smartphones (Galaxy S and Galaxy Note series).
- For improved performance, the Samsung Family Hub app is subject to change without notice. Support may be discontinued according to the manufacturer's policy.
- Wireless networks may be affected by the surrounding wireless communication environment.
- If your Internet service provider has registered the MAC address of your PC or modem for identification, your Samsung Smart Refrigerator may fail to connect to the Internet. If this happens, contact your Internet service provider for technical assistance.
- The firewall settings of your network system may prevent your Samsung Smart Refrigerator from accessing the Internet. Contact your Internet service provider for technical assistance. If this symptom continues, contact a local Samsung service center or retailer.

### Samsung account

You are required to register your Samsung account to use the Samsung Family Hub app. If you don't have a Samsung account, follow the app's onscreen instructions to create a free Samsung account.

**NOTE:** To connect your smartphone and the refrigerator, register your Samsung account in Settings → Profile.

Item	Description
Calendar	You can share your schedule with your family.
To Do	You can create and edit a to-do list.
Memo	You can bring a Memo from your refrigerator to your smartphone or send a Memo from your smartphone to your refrigerator.
White Board	You can bring a White Board message from your refrigerator to your smartphone or send a White Board message from your smartphone to your refrigerator.
Gallery	You can send photos from your smartphone to the refrigerator
View Inside	You can check the inner view of the refrigerator, use different labels to register item-specific storage periods, and keep track of them to ensure you use items by their use-by dates.
Shopping List	You can create and edit shopping lists.

## Special features

The refrigerator has features convenient for you.

### Water dispenser

With the water dispenser, you can dispense water without opening the fridge door.

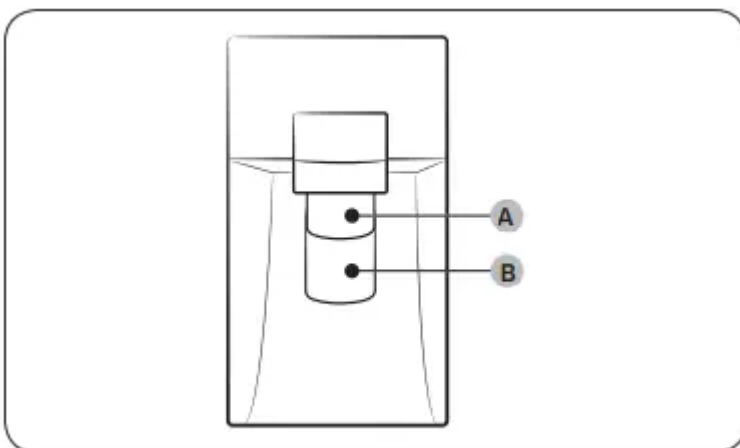

The water dispenser offers 3 options: chilled water, cubed ice, and crushed ice. If you do not want to dispense ice, simply press water lever (B).

With the Ice Maker enabled,

1. Press to select an ice type.

2. Put a water glass on the ice lever (A) and push it. Ice is dispensed from the dispenser.
3. Then, put the glass on the water lever (B) and push it. Water is dispensed from the dispenser.

**NOTE:**

- To get ice and water, push the ice lever (A) first for ice, then move your glass down and press the water lever (B) for water.
- If you push both levers at once, only the first pushed lever operates.
- To prevent spills, wait 1 second before removing the glass after dispensing.
- Make sure the glass is in line with the dispenser to prevent the dispensed water from spilling out.
- If you do not use the water dispenser for 2-3 days, the dispensed water may have an abnormal smell or taste. This is not a system failure. Discard the first 1-2 glasses of water.

**Ice maker**

The refrigerator has a built-in ice maker that automatically dispenses ice so that you can enjoy filtered water with cubed or crushed ice to your preference.

Ice making

To ensure proper ice making and keep the ice bucket available with ice after using the refrigerator for the first time, follow these instructions:

1. Let the refrigerator operate for at least 24 hours to ensure optimal performance.
2. Dispense the first 4 to 6 ice cubes into a glass.
3. Wait another 8 hours and dispense another 4 to 6 ice cubes.
4. Then, wait another 16 hours and dispense the first glass-full of ice.

**NOTE:**

- If you consume all the ice at once, you must wait 8 hours before dispensing the first 4 to 6 cubes. This ensures that the ice bucket is filled with ice properly.
- The ice cubes generated rapidly may look white, which is normal.

Diagnosis



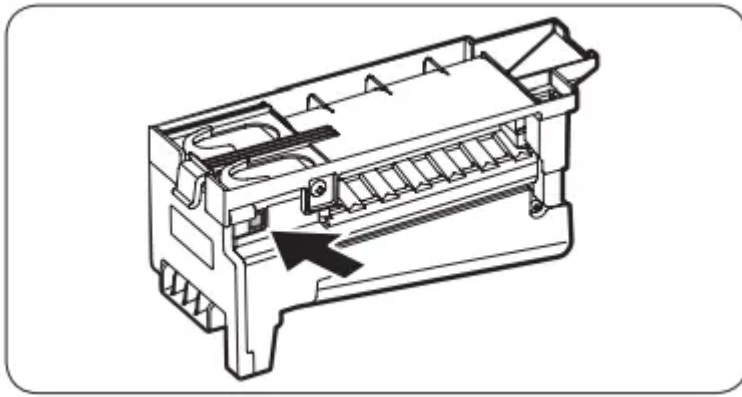

If ice does not dispense, first check the ice maker.

To check the ice maker

1. Press Test on the side of the ice maker. You will hear a chime (ding-dong) at the press of the button.
2. You will hear another chime if the ice maker operates properly.

**CAUTION:**

- If the ice making chime rings repeatedly, contact the waterline installer or a local Samsung service center.
- Do not press the button repeatedly after the ice tray is filled with ice or water. Water may overflow or ice may jam.
- Do not put food in the ice bucket. The frozen food may damage the ice maker, especially when opening or closing the door.
- When the refrigerator recovers power supply after a power failure, the ice bucket may contain a mix of melted and jammed ice cubes, resulting in a system failure. To prevent this, make sure to empty the ice bucket before using the refrigerator.
- Do not put fingers or other objects into the dispenser hole or the ice maker. This may cause physical injury or property damage.
- When reinserting the ice maker tray, make sure that the tray is properly centered at the entrance. Otherwise, the tray may be stuck.

**Ice Maker Off**

To disable the icemaker, tap Fridge Manager > Fridge Settings > Ice Maker on the Home screen, and then select Off. Make sure to empty the ice bucket. Remaining ice cubes may clump together, making it difficult to remove them.

To remove the ice bucket

1. Hold the bottom of the ice bucket with one hand and hold the side with the other hand.



2. Gently lift up and pull out.

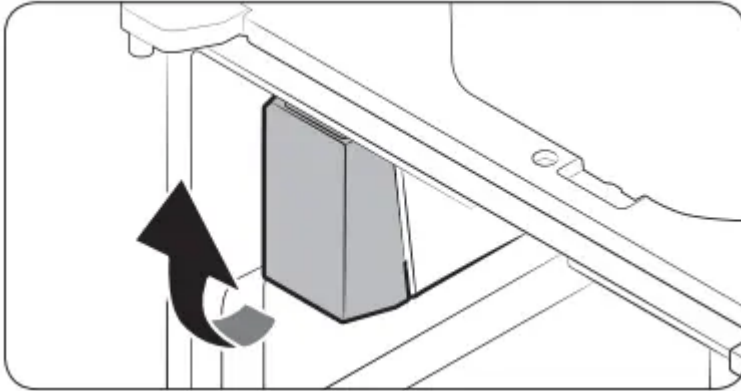

3. Remove the remaining ice cubes and put the ice bucket back into place.

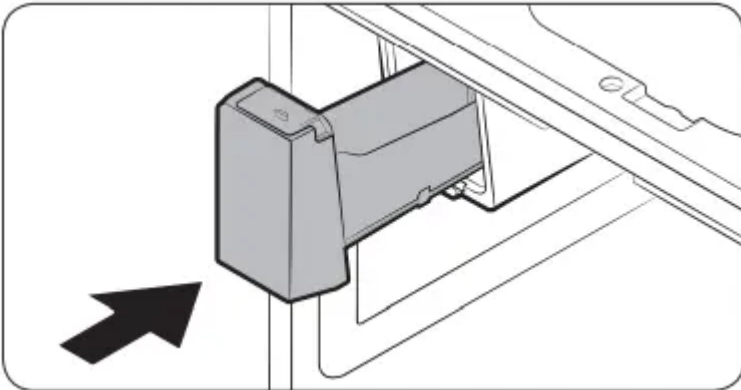

If the ice bucket is not firmly inserted, turn the ice screw by 90 degrees and try again.

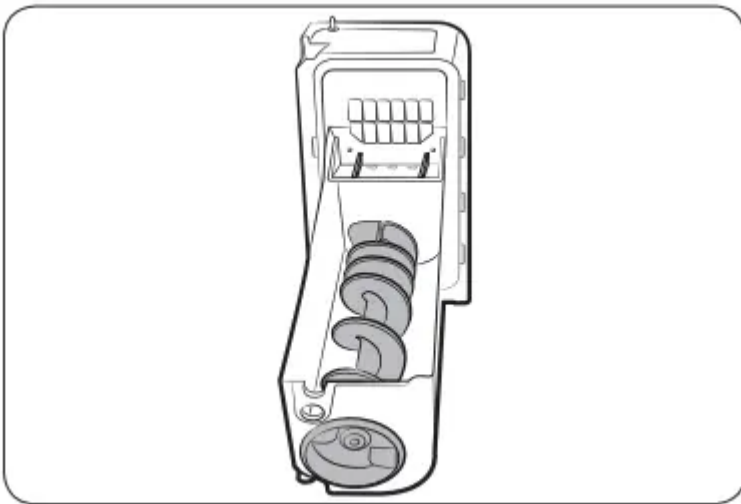

**NOTE:** Removal of the ice bucket does not affect the thermal and mechanical performance of the refrigerator

Water clouding

Water supplied to the refrigerator flows through a core alkaline filter of any kind. During this filtering process, the water that has flowed through the filter increases in the water pressure and becomes saturated with oxygen and nitrogen. This causes the water to look misty or

cloudy temporarily when dispensed. This is normal and the water will look clear after a few seconds

## Wine Rack

The refrigerator ships with a wine rack, which can be positioned in one of 3 positions: under the shelf, in the partition guide, or on top of the sliding shelf of the Cool Select+ (FlexZone). The position or positions available to you depends on your model.

**CAUTION:** When you remove or insert the wine rack, make sure that the wine rack is empty.

Under the shelf

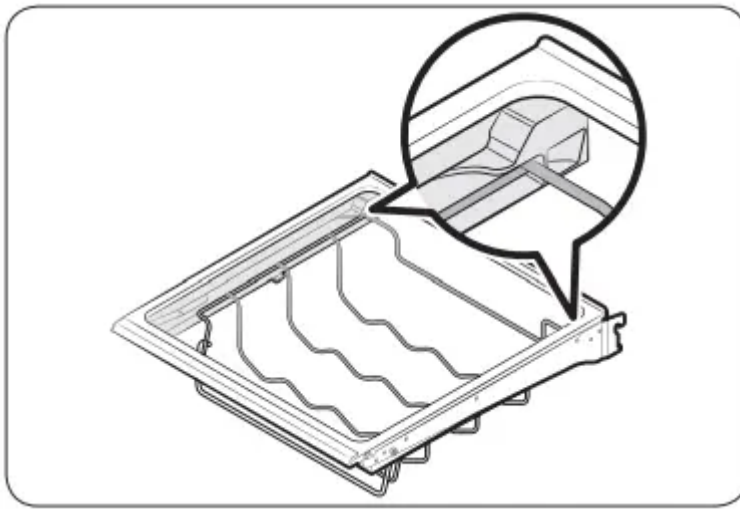

Insert the wine rack under the shelf of the fridge. Make sure to insert it all the way to the end as shown in the figure.

In the partition guide

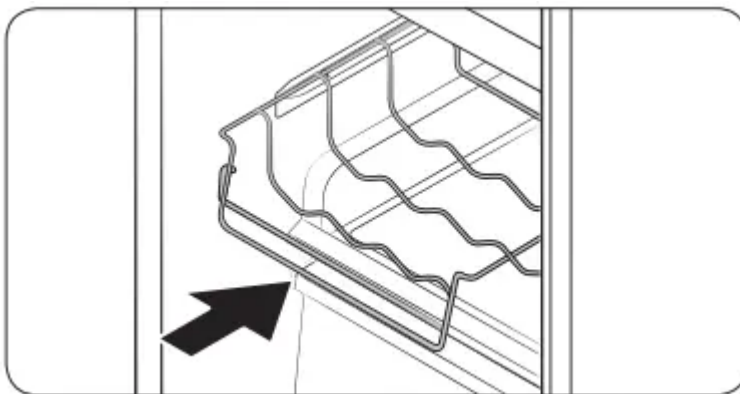

Insert the wine rack in the partition guide of the Cool Select+ (FlexZone).

- Make sure the front of the wine rack fits in the partition guide on the inner left-hand side of the Cool Select+ (FlexZone).
- Set the temperature of the Cool Select+ (FlexZone) to White Wine.

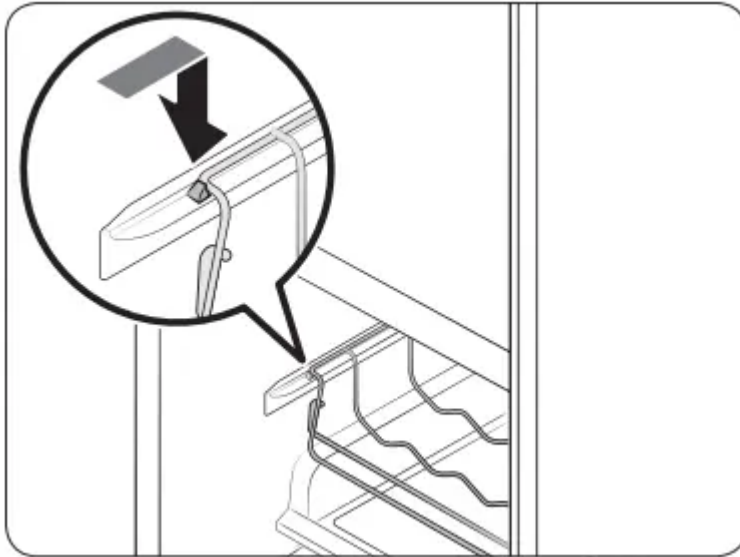

On the sliding shelf

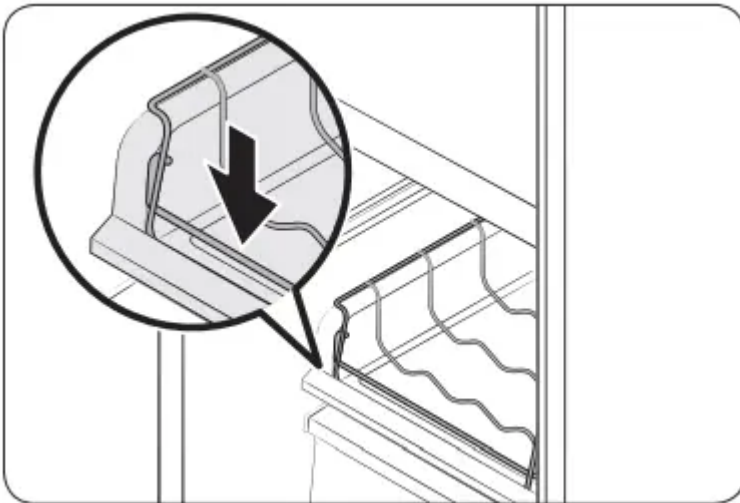

Insert the wine rack on top of the sliding shelf of the Cool Select+ (FlexZone), which is normally below the partition guide.

Set the temperature of the Cool Select+ (FlexZone) to White Wine.

**CAUTION:**

- Do not store wine bottles in the freezer. The bottles can freeze and break, causing physical injury.
- Do not store wine bottles in two rows. The bottles may fall, causing physical injury.
- Do not store wine bottles taller than 13 in (330 mm) in height. The bottles may break when you close the door, causing physical injury.

# Maintenance

## Handle and care

### Ice bucket

If you do not dispense ice for an extended period, ice may form clumps inside the bucket.

If this happens, remove and empty the ice bucket.

1. To remove the ice bucket, gently lift it up and pull out slowly while holding the bottom of the bucket with one hand and the side with the other hand.
2. Lift up and pull the bucket out. Empty the bucket.

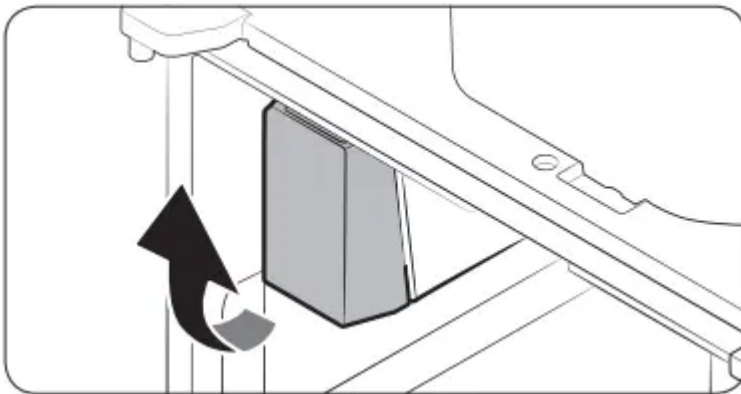

3. When done, put the bucket back into position. If the bucket does not fit in, turn the helix screw by 90 degrees and try again.

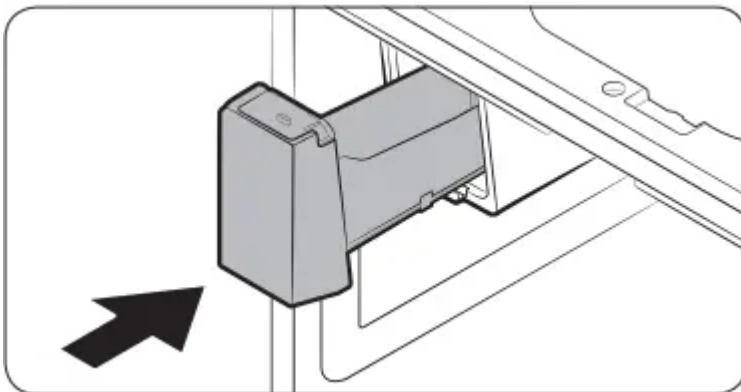

### CAUTION:

- Do not apply excessive force to the bucket cover. The cover may break.
- Do not forcefully close the door. Water may spill over the ice maker.
- To prevent injury, make sure to clean up any ice or water that has fallen on the floor.
- To prevent accidents or injury, do not let children play with the water dispenser or the ice maker.
- Do not put your hand or an object into the ice chute. This may cause physical injury or product damage.

- Use only the provided ice bucket. Third-party ice buckets may cause a system failure.
- Use only potable water that is connected to the water supply line.

**NOTE:**

- The required water pressure for ice making is between 20 psi and 125 psi.
- Any sound from the ice maker is normal, which outputs during the ice making process.
- While the door is open, neither the ice maker nor the water dispenser operates.

**Tempered glass shelves (fridge)**

- To remove a shelf, fully open the corresponding door. Hold the front of the shelf, and then gently lift up and slide out.

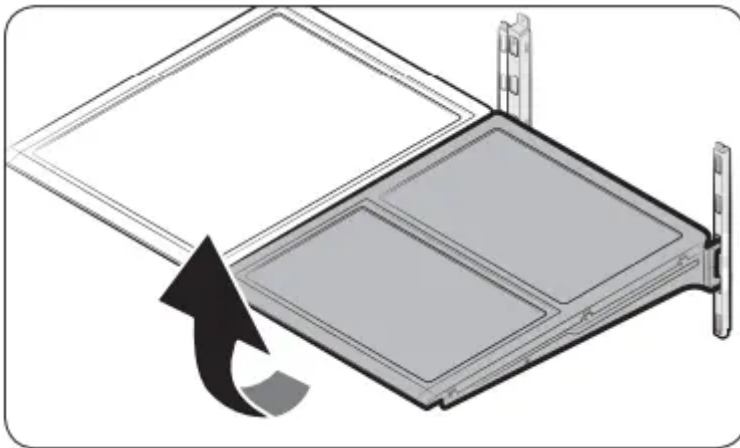

- To reinsert, lower the rear side of the shelf and insert into the shelf hooks. Then, lower the front side to slide in to the end.

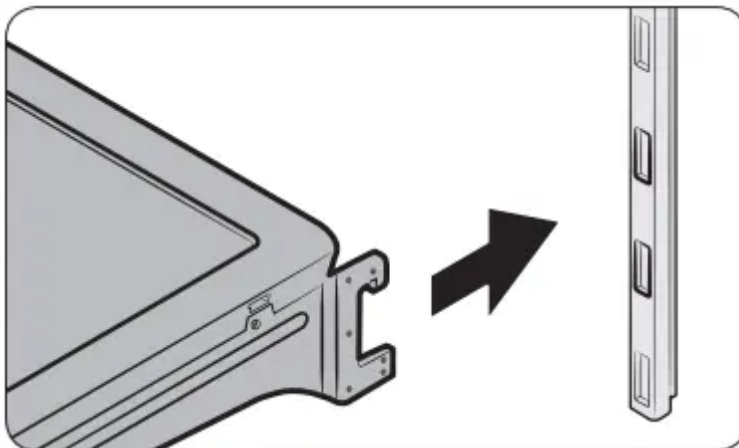

**CAUTION:**

- The tempered glass shelves are heavy. Use caution when removing them.
- The shelf must be inserted correctly. Do not insert upside down.
- Glass containers may scratch the surface of glass shelves.

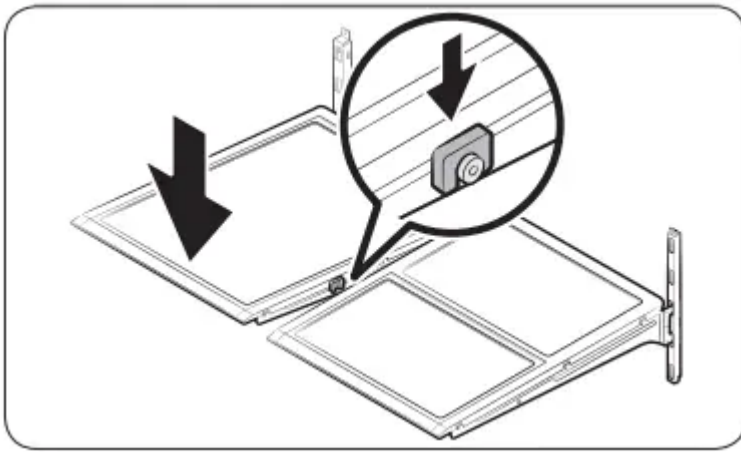

### Door bins

The top door bin section has a marked line to ensure easy removal and proper reinsertion.

Lift up the door bin, and then pull out straight.

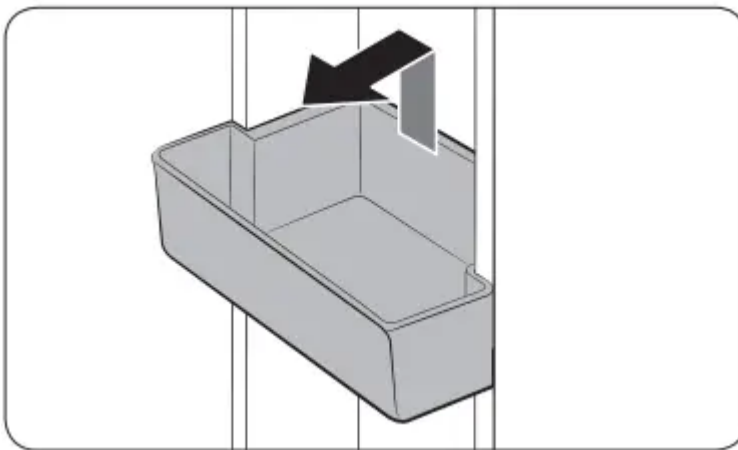

**CAUTION:** Do not allow children to play with the bins. Sharp-edged corners may cause injury.

### Vegetable & fruit drawers

Gently lift up the front of the drawer and slide out.

It is recommended to remove the door bins before removing the drawer. This is to prevent damage to the door bins.

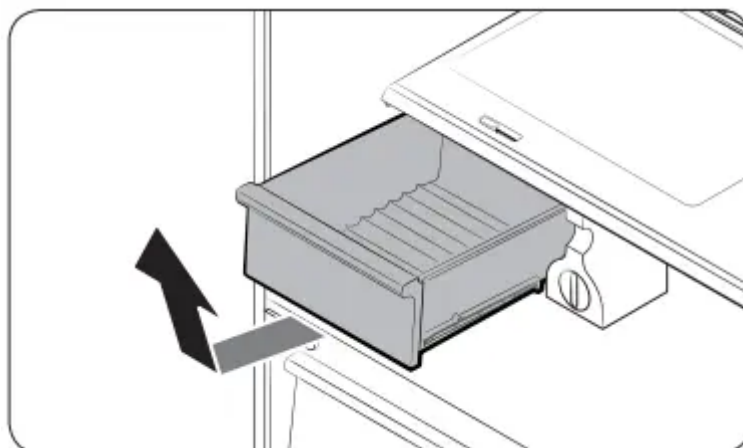

## Vegetable shelf

1. Slide out the left-sided vegetable drawer.

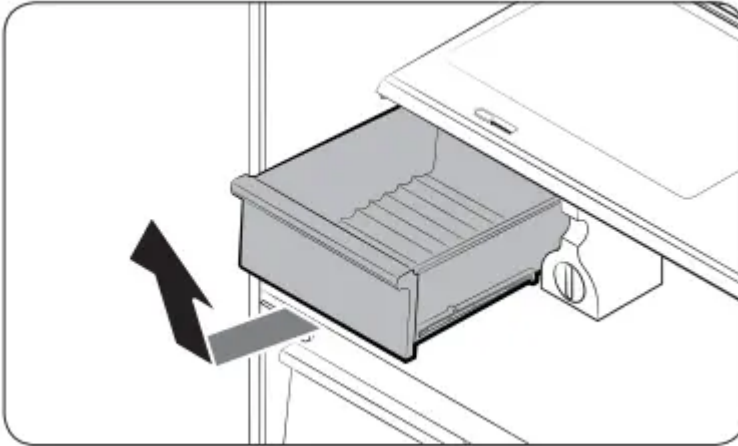

**NOTE:** The actual image and provided component parts of the refrigerator may differ, depending on the model and the country.

2. Slide in the right-sided foldable shelf

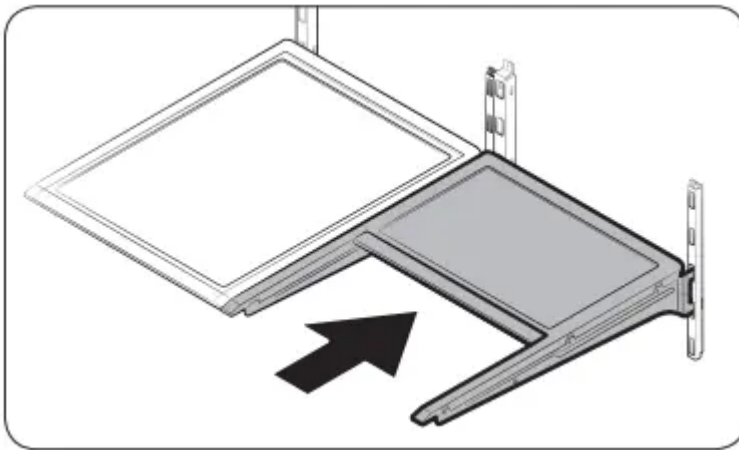

3. While supporting the vegetable shelf with one hand, slide out with the other hand.

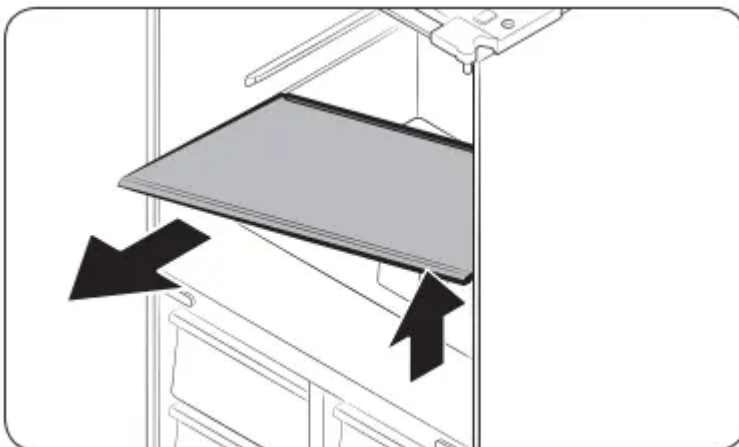

**NOTE:** Using the space that is revealed after removing the foldable shelf, take out the vegetable shelf. To reinsert, follow the steps above in the reverse order.

## Ice bucket

To remove the ice bucket, see the Maintenance section

## **Cleaning**

Interior and exterior

### **WARNING:**

- Do not use benzene, thinner, or home/car detergent such as Clorox™ for cleaning purposes. They may damage the surface of the refrigerator and cause a fire.
- Do not spray water onto the refrigerator. This may cause electric shock.
- Do not put fingers or other objects into the dispenser hole.

### **CAUTION:**

- Do not spray water directly on the LCD display or speaker. This may cause fire, electric shock, or damage.
  - Do not scratch the LCD display or speaker. This may cause permanent damage.
  - Regularly use a dry cloth to remove all foreign substances such as dust or water from the power plug terminals and contact points.
1. Unplug the power cord.
  2. Use a moistened, soft, lint-free cloth or paper towel to clean the refrigerator's interior and exterior.
  3. When done, use a dry cloth or paper towel to dry well.
  4. Plug in the power cord.

### **Inner-view camera**

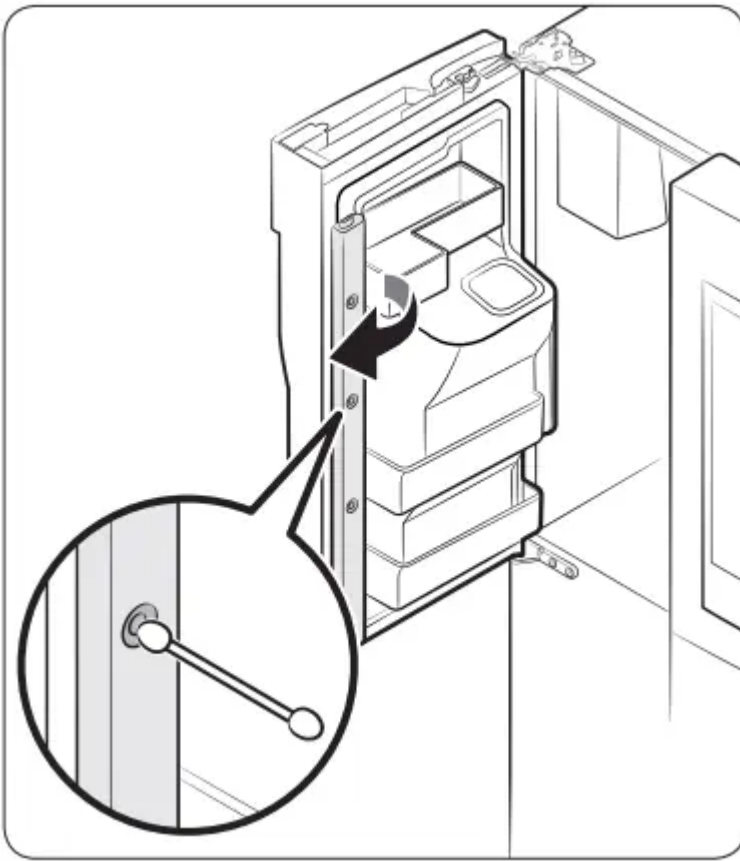

**NOTE:** Use a cotton swab or microfiber cloth to clean the camera on the left-side door of the fridge.

## Replacement

### Water filter

#### **WARNING:**

- Do not use third-party water filters. Use only Samsung-provided or -approved filters.
- Unapproved filters may leak and damage the refrigerator, causing electric shock. Samsung holds no responsibility for any damage that may occur from use of thirdparty water filters.

The filter indicator (  ) turns red as a reminder that lets you know it is time to replace the water filter. Before replacing the filter, make sure the water supply line is shut off.

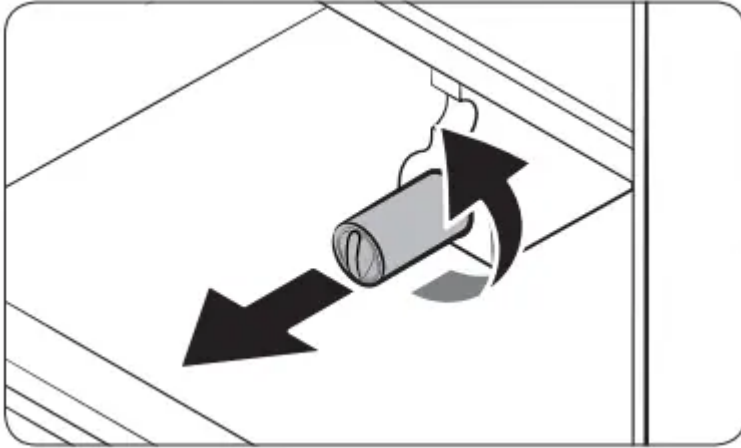

1. Turn the knob of the filter cartridge counter clockwise by 90 degrees (1/4 turn). The filter cartridge unlocks.

2. Pull out to remove the cartridge.

- If the water filter is contaminated severely, the cartridge may not be easily removable. In that case, pull out by force.

- To prevent water leaks from the opening, keep the cartridge in line while removing it.

**NOTE:** To prevent overflow, empty and dry the water filter tray

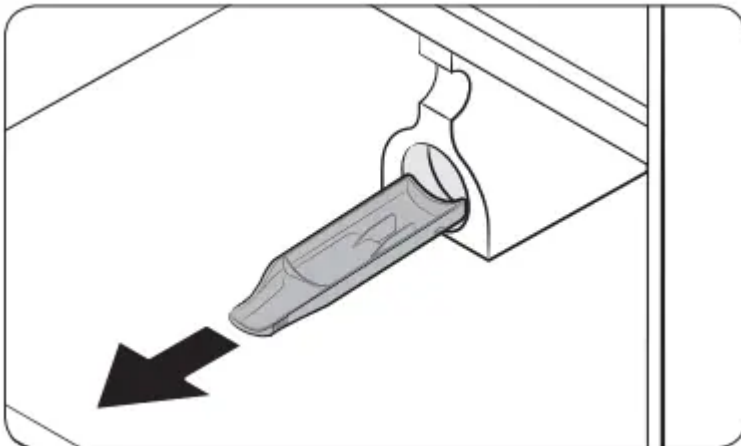

3. Insert a new filter cartridge. Use only Samsung-provided or -approved filters.

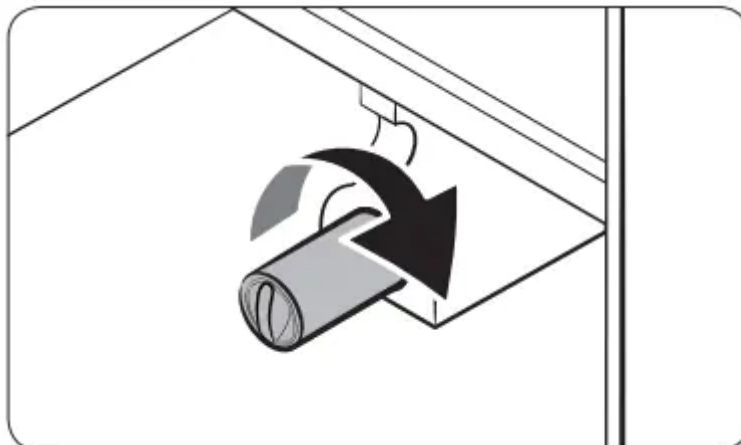

4. Turn the cartridge knob clockwise to lock into place.
5. On the Home screen, tap Fridge Manager > Fridge Settings > Water Filter, and then select Reset. The filter indicator turns blue.
6. When replacing is complete, open the water valve and run water through the dispenser for about 7 minutes. This is to remove impurities and air from the water line.

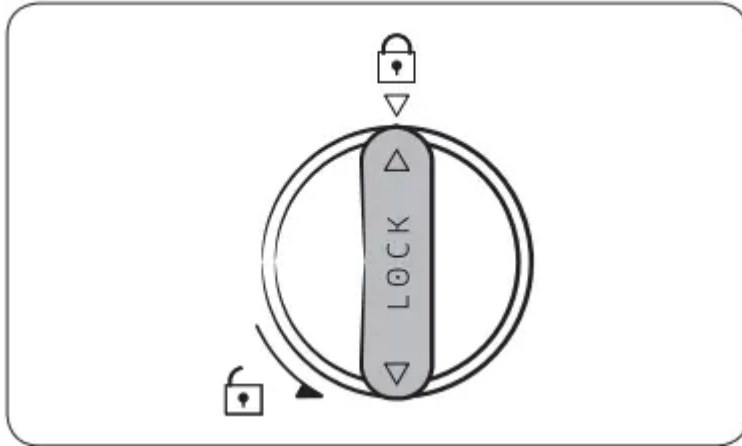

**NOTE:**

A newly installed filter may cause the water dispenser to spurt water briefly. This is because of air entering the waterline.

This replacement process cause the refrigerator to drip water onto the floor. Simply wipe up with dry cloths.

Reverse osmosis water filtration system

The water pressure of the water supply system to a reverse osmosis water filtration system must be between 35 psi and 120 psi (241 kPa and 827 kPa). The water pressure of the reverse osmosis water filtration system to the refrigerator’s cold water line must be at least 40 psi (276 kPa). If the water pressure is below the specified:

- Check if the sediment filter in the reverse osmosis system is blocked. Replace the filter if necessary.
- Refill the water tank in the reverse osmosis system with water.
- If your refrigerator has a water filter, it may further reduce the water pressure when used in conjunction with a reverse osmosis system. Remove the water filter.

For more information or servicing, contact a licensed plumbing professional.

Ordering a new filter

To purchase a new water filter, contact a local Samsung service center.

**LED Lamps**

To replace the lamps of the refrigerator, contact a local Samsung service centre.



**WARNING:** The lamps are not user-serviceable. Do not attempt to replace a lamp yourself. This can cause electric shock.

## Troubleshooting

### General

#### Temperature

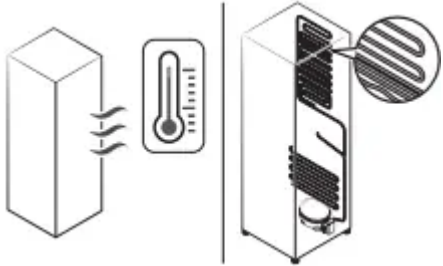

Symptom	Possible causes	Solution
Fridge/freezer does not operate.  Fridge/freezer temperature is warm	Power cord is not plugged in properly.	Properly plug in the power cord.
	Temperature control is not set correctly.	Set the temperature lower.
	Refrigerator is located near a heat source or direct sunlight.	Keep the refrigerator away from direct sunlight or a heat source.
	Not enough clearance between refrigerator and nearby walls or cabinets.	We recommend that the gap between the refrigerator and nearby walls (or cabinets) is more than 50 mm.
	The refrigerator is overloaded. Food is blocking the refrigerator vents.	Do not overload the refrigerator. Do not allow food to block ventilation.
Fridge/freezer is over-cooling.	Temperature control is not set correctly.	Set the temperature higher.
Interior wall is hot.	Refrigerator has heat-proof piping in the interior wall.	<p>To prevent condensation from forming, the refrigerator has heat-proof piping in the front corners. If the ambient temperature rises, this equipment may not work effectively. This is not a system failure.</p> 

## Odors

Symptom	Possible causes	Solution
Refrigerator has odors.	Spoiled food.	Clean the refrigerator and remove any spoiled food.
	Food with strong odors.	Make sure strong smelling food is wrapped airtight.

## Frost

Symptom	Possible causes	Solution
Frost around the vents.	Food is blocking the vents.	Make sure no food blocks the refrigerator vents.
Frost on interior walls.	Door is not closed properly.	Make sure food does not block the door. Clean the door gasket.
Fruits or vegetables are frozen	Fruits or vegetables are stored in the Cool Select+ and the temperature was set too low.	Set the temperature of the Cool Select+ to a temperature appropriate for fruits or vegetables.

## Condensation

Symptom	Possible causes	Solution
Condensation forms on the interior walls.	If door is left open, moisture enters the refrigerator.	Remove the moisture and do not leave a door open for extended periods of time.
	Food with high moisture content.	Make sure food is wrapped airtight.

## Water/ice (dispenser models only)

Symptom	Possible causes	Solution
Water flow is weaker than normal.	Water pressure is too low	Make sure the water pressure is between 20 to 120 psi.
Ice maker makes a buzzing sound	The ice maker function is activated, but the water supply to the refrigerator has not been connected.	Turn off the ice maker.
Ice maker does not make ice.	Ice maker has just been installed.	You must wait 12 hours for the refrigerator to make ice.
	Freezer temperature is too low.	Set the freezer temperature below -18 °C or -20 °C in warm, ambient air.
	Dispenser Lock is activated.	Deactivate Dispenser Lock.
	Ice maker is off.	Turn on the ice maker.
Ice does not dispense.	Ice may jam if the ice dispenser is not used for a long time (approx. 3 weeks).	If you won't be using the refrigerator for a long time, empty the ice bucket and turn off the ice maker.
	Ice bucket is not properly inserted.	Make sure the ice bucket is properly inserted.
	Water line is not connected properly or water supply is not on.	Check if the water line is installed correctly. Check if the water line stop cock is closed.
Water does not dispense.	Water line is not connected properly or water supply is not on.	Check the water installation conditions.

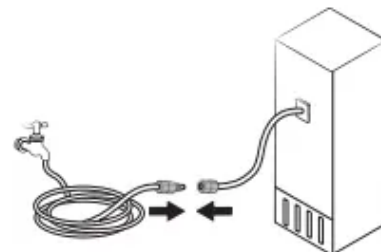

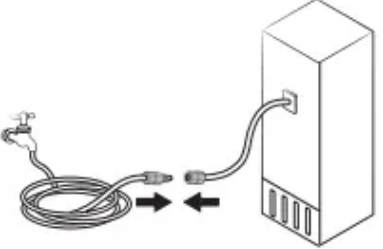
Symptom	Possible causes	Solution
		
	Dispenser Lock is activated.	Deactivate Dispenser Lock.
	A third-party water filter was installed.	<p>Use only Samsung-provided or approved filters.</p> <p>Unapproved filters may leak and damage the refrigerator</p>
	Water filter indicator turns on or blinks	<p>Replace the water filter. After replacing, reset the filter in Fridge Manager &gt; Fridge Settings &gt; Water Filter.</p>



## SmartThings

Symptom	Action
Could not find “SmartThings” in the app market.	The SmartThings app is designed for Android 6.0 (Marshmallow) or later, iOS 10.0 or later, iPhone 6 or later, and is optimized for Samsung smartphones (Galaxy S and Galaxy Note series).
The SmartThings app fails to operate.	The SmartThings app is available for applicable models only.  The old Samsung Smart Refrigerator app cannot connect with Samsung Smart Home models.
The SmartThings app is installed but is not connected to my refrigerator.	You must log into your Samsung account to use the app.  Make sure that your router is operating normally.  If you have not connected your refrigerator to the SmartThings App after the app was installed, you must make the connection using the device registration function of the app.
Could not log into the app.	You must log into your Samsung account to use the app.  If you don't have a Samsung account, follow the app's onscreen instructions to create one.
An error message appears when I try to register my refrigerator.	Easy Connection may fail due to the distance from your access point (AP) or electrical interference from the surrounding environment. Wait a moment and try again.
The SmartThings app is successfully connected to my refrigerator but does not run.	Exit and restart the SmartThings app or disconnect and reconnect the router.  Unplug the power cord of the refrigerator, and then plug it in again after 1 minute.

## Samsung Family Hub

Symptom	Action
Could not find “Samsung Family Hub” in the app market.	The Samsung Family Hub app is available for smartphones that run Android 4.4 (KitKat) or higher, or iOS 8.0 or higher.
Could not log into the app.	You must log into your Samsung account to use the app.  If you don't have a Samsung account, follow the app's onscreen instructions to create one.

## LCD

Symptom	Action
Cannot connect to my TV.	This refrigerator can connect only with Samsung Smart TV. Launched in 2015-17: J/K/MU6400 series or above. Launched in 2018: NU7400 series or above. Launched in 2018: Q60R series or above. Please check the model name of your TV first.  Network connections may suffer temporary interruptions. Turn your TV off, and then try again.
The inner view picture looks bulged out or incomplete.	The edges of the inner view may look bulged out. The bulging is caused by the convex lens of the camera.  The inner view may be incomplete due to the blind spots on the left and right corners or screened depending on the layout of food items. Make sure to place food items in the front center.
The displayed measurement on the Fridge Manager is not correct.	The displayed conditions may differ from the actual temperature and humidity.

## Do you hear abnormal sounds from the refrigerator?

Before calling for service, review the checkpoints below. Any service calls related to normal sounds will be charged to the user.

### These sounds are normal.

When starting or ending an operation, the refrigerator may make sounds similar to a car engine igniting. As the operation stabilizes, the sounds will decrease.

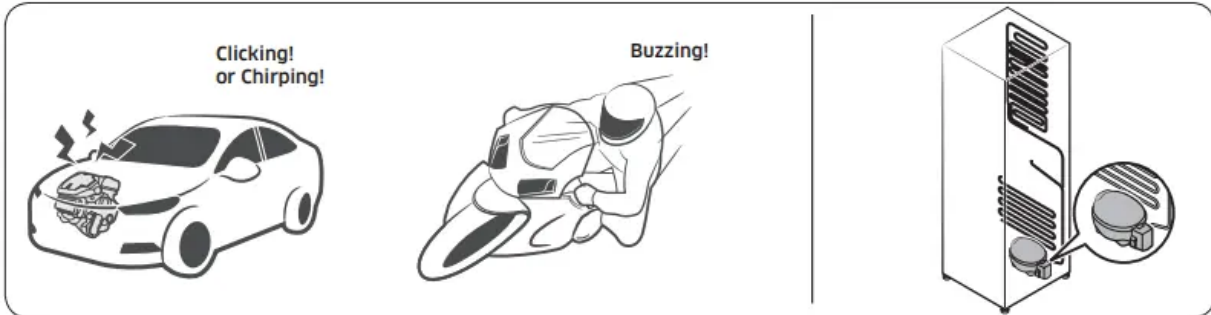

While the fan is operating, these sounds may occur. When the refrigerator reaches the set temperature, no fan sound will occur.



During a defrost cycle, water may drip on the defrost heater, causing sizzling sounds.

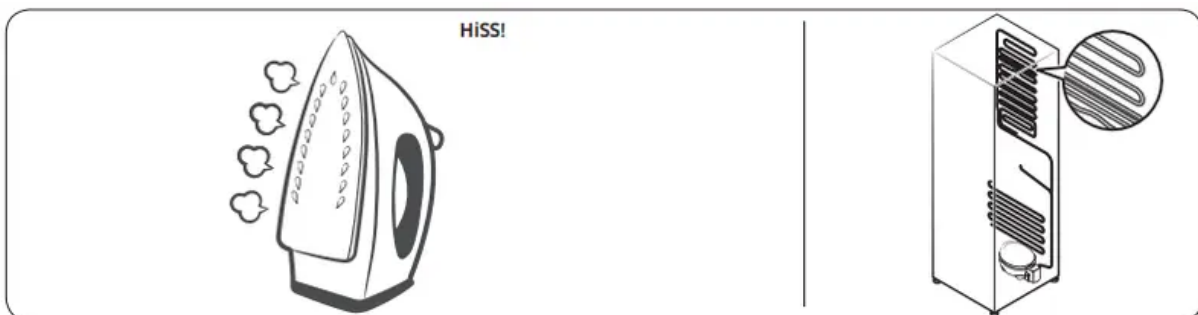

As the refrigerator cools or freezes, refrigerant gas moves through sealed pipes, causing bubbling sounds.

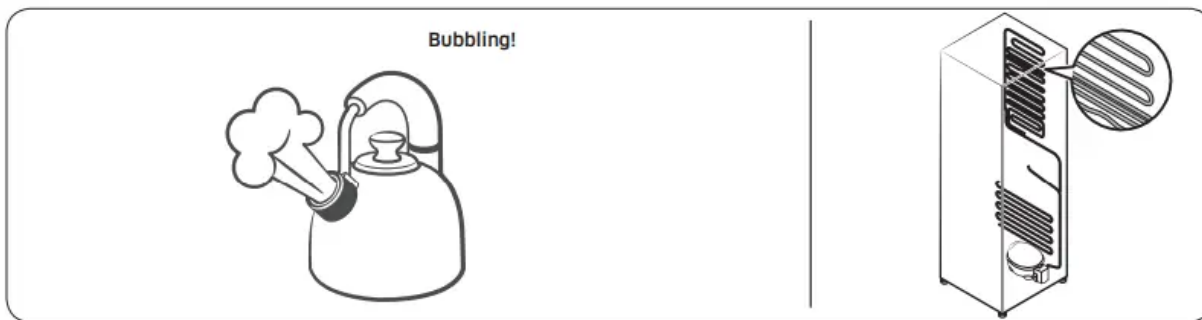

As the refrigerator temperature increases or decreases, plastic parts contract and expand, creating knocking noises. These noises occur during the defrosting cycle or when electronic parts are working.

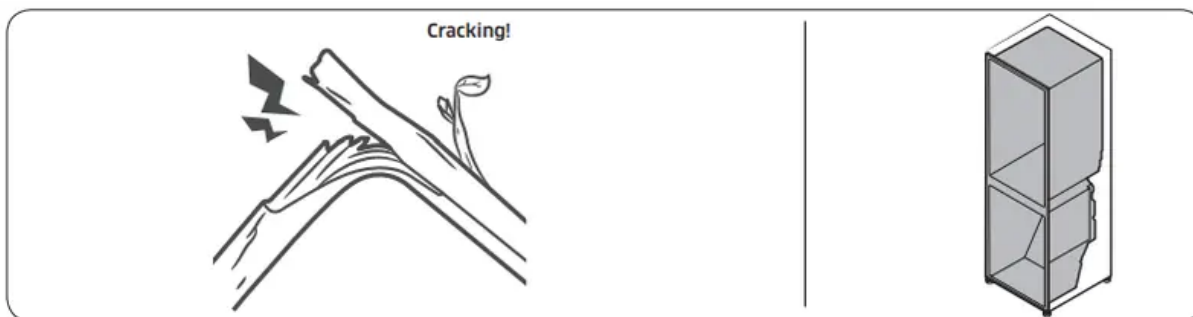

For ice maker models: When the water valve opens to fill the ice maker, buzzing sounds may occur.

Due to pressure equalizing when opening and closing the refrigerator door, whooshing sounds may occur.

### Warning

This content is compiled from multiple sources and is provided for reference purposes only. It may not be complete or fully applicable to all situations. If you are unable to resolve your issue, please contact the product manufacturer or an authorized service provider for official support.