

GETTING TO KNOW YOUR SMART AIR PURIFIER

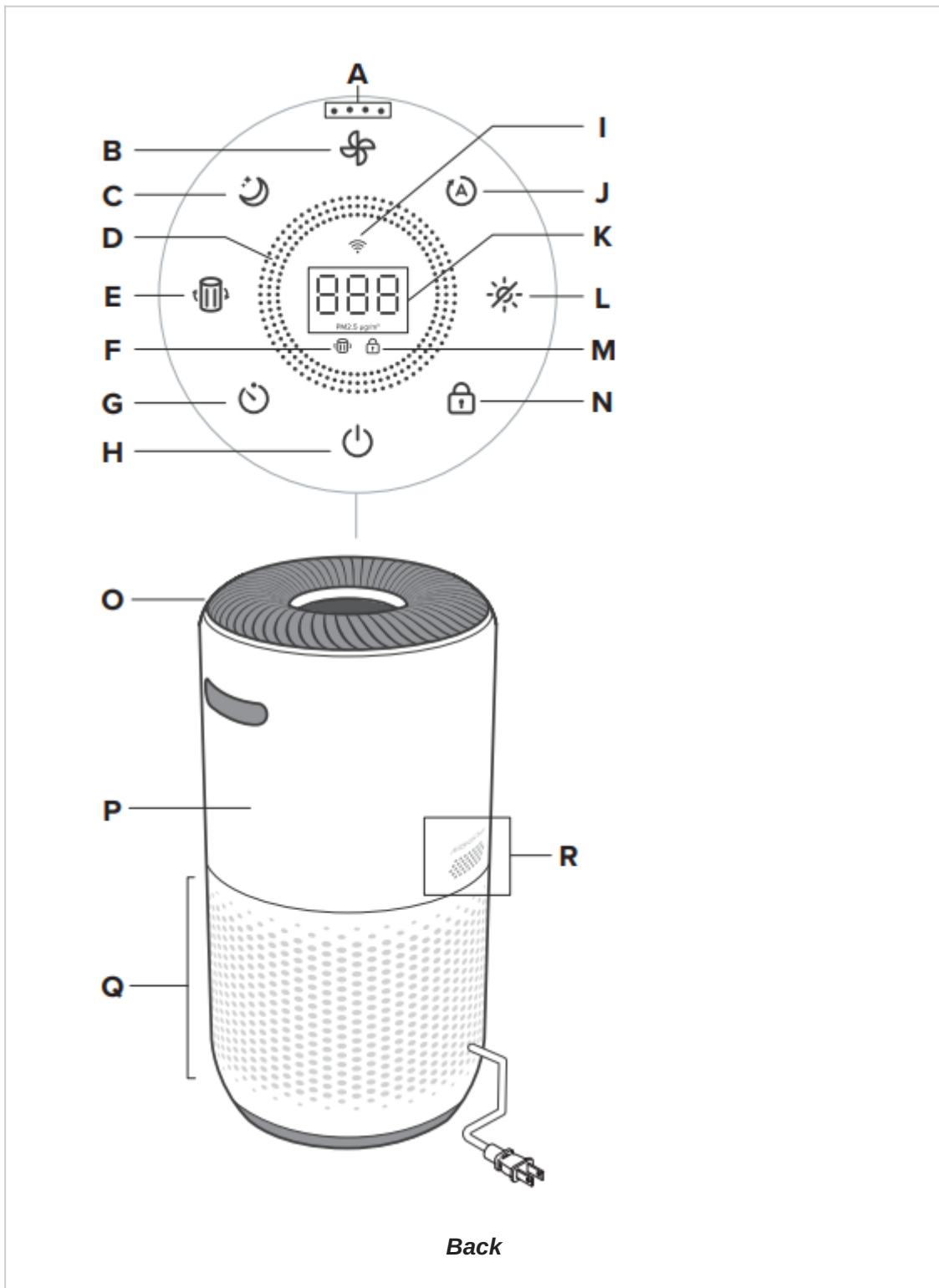

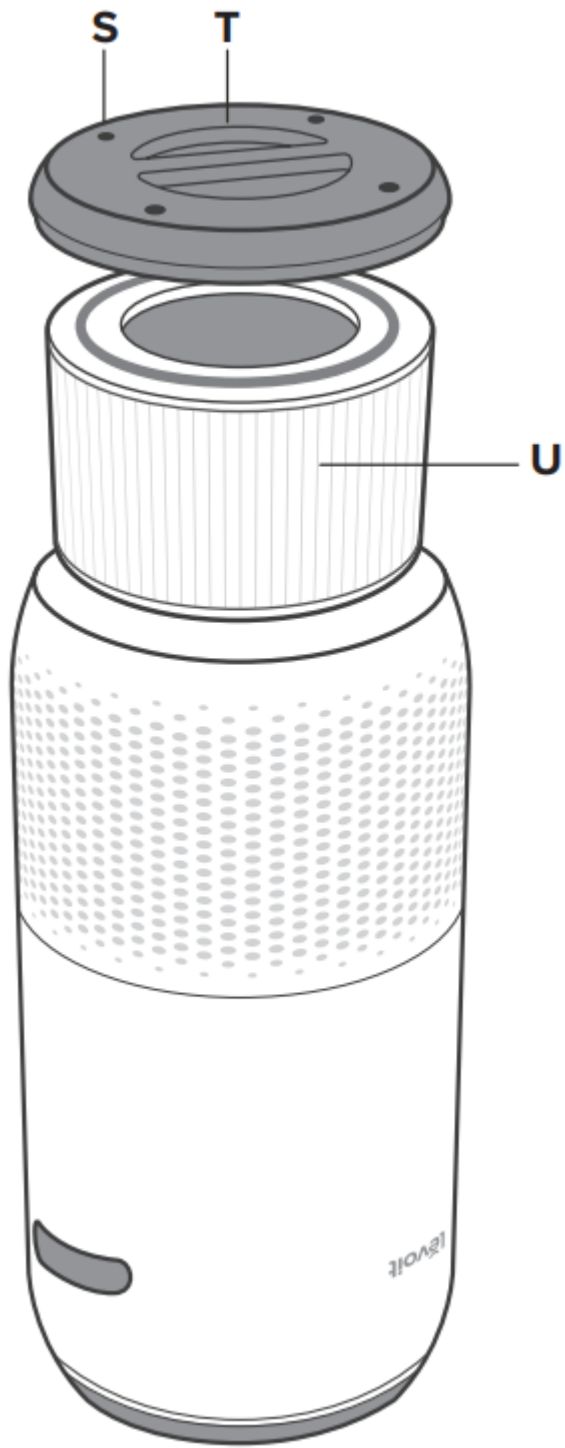

Front, upside down





A. Fan Speed Indicators	L. Display Off Button
B. Fan Speed Button	M. Display Lock Indicator
C. Sleep Mode Button	N. Display Lock Button
D. Air Quality Indicator Rings	O. Air Outlets
E. Check Filter Indicator Reset Button	P. Housing
F. Check Filter Indicator	Q. Air Inlets
G. Timer Button	R. AirSight™ Plus Laser Dust Sensor
H. On/Off Button	S. Anti-Skid Pads
I. Wi-Fi® Indicator	T. Filter Cover
J. Auto Mode Button	U. True HEPA 3-Stage Original Filter
K. PM2.5/Timer Display	



CONTROLS & DISPLAY



	<p>On/Off Button</p> <ul style="list-style-type: none"> • Turns the air purifier on/off. • Press and hold to configure the air purifier. See the VeSync in-app instructions for more information. • Press and hold to reset the air purifier and disconnect from Wi-Fi
	<p>Air Quality Indicator Rings</p> <ul style="list-style-type: none"> • These indicators use an automatic sensor to display the air quality: Blue (Very Good), Green (Good), Orange (Moderate), and Red (Bad).
	<p>Wi-Fi® Indicator</p> <ul style="list-style-type: none"> • Turns on, off, or blinks to indicate pairing status. See the VeSync in-app instructions for more information.
	<p>Fan Speed Button</p> <ul style="list-style-type: none"> • Cycles through fan speeds: low (1 indicator will light up), medium (2 indicators), high indicators), and turbo indicators). • Tapping the Fan Speed Button while the air purifier is in Auto Mode or Sleep Mode (if the display is on) will exit that mode.
	<p>Sleep Mode Button</p> <ul style="list-style-type: none"> • Turns Sleep Mode on/of
	<p>Timer Button</p> <ul style="list-style-type: none"> • Cycles through timer options • Press and hold  for 2 seconds to begin cycling through the timer options in 1-hour increments.
	<p>Auto Mode Button</p> <ul style="list-style-type: none"> • Turns Auto Mode on/of

	<p>Display Off Button</p> <ul style="list-style-type: none"> • Turns the display off. • Tap any button (except ) to turn the display back on.
	<p>Display Lock Button</p> <ul style="list-style-type: none"> • Prevents current settings from being changed. Press and hold for seconds to turn Display Lock on/off. • The Display Lock Indicator  will blink when any other button is tapped to indicate that Display Lock is on.
	<p>Check Filter Indicator Reset Button</p> <ul style="list-style-type: none"> • Press and hold for 3 seconds to reset the Check Filter Indicator. • The Check Filter Indicator lights up when the filter should be checked

GETTING STARTED

1. Flip the air purifier over or turn it on its side. Twist the filter cover counterclockwise and remove it.

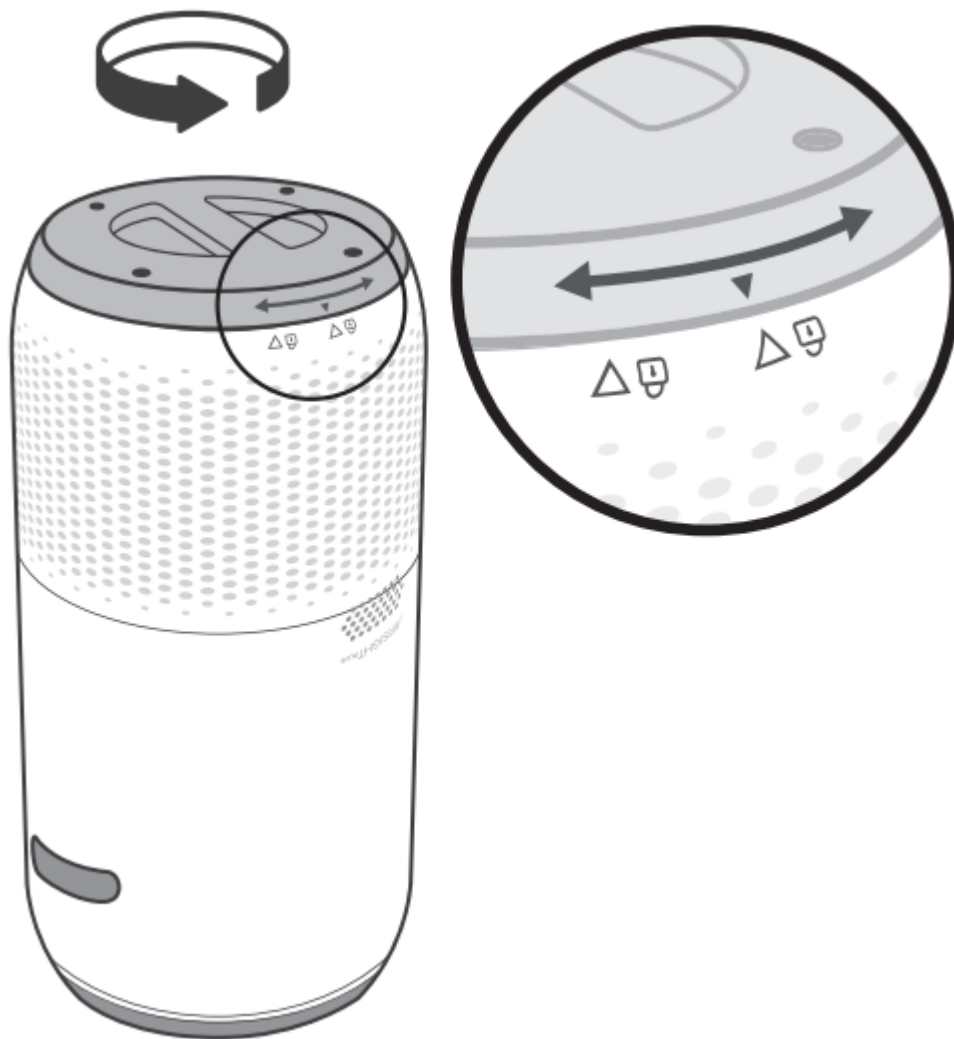

2. Remove the filter from its plastic packaging and place the filter back into the air purifier

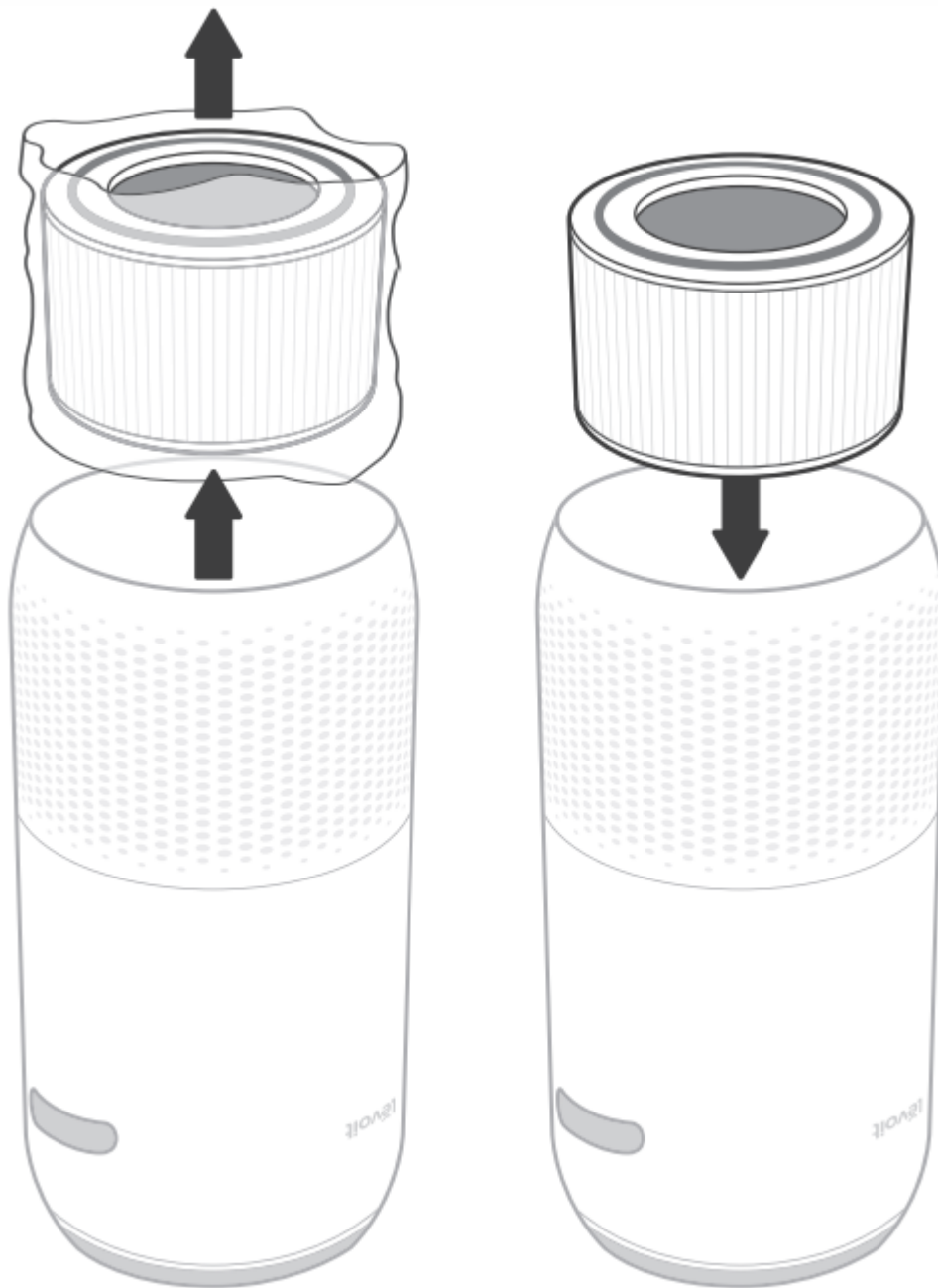

3. Replace the filter cover and twist clockwise to lock

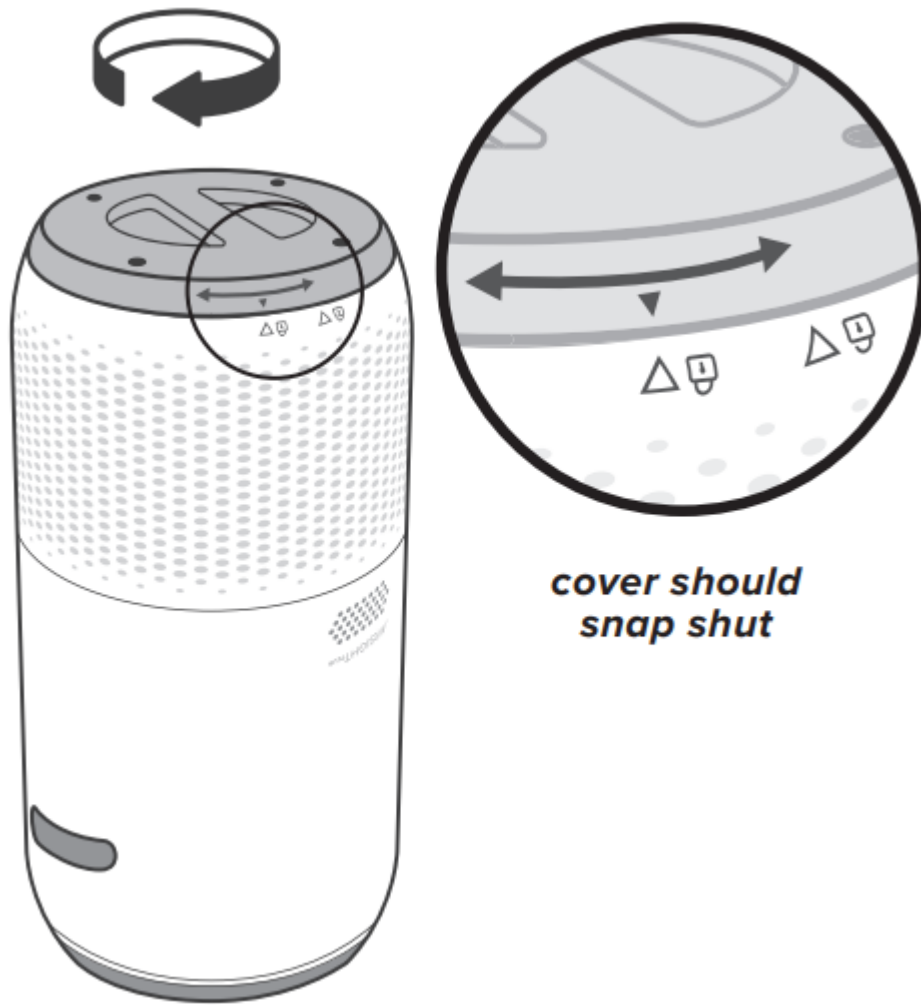

4. Place the purifier on a flat, stable surface with the display facing up. Allow at least 15 inches / 38 cm of clearance on all sides. Keep away from anything that would block airflow, such as curtains.

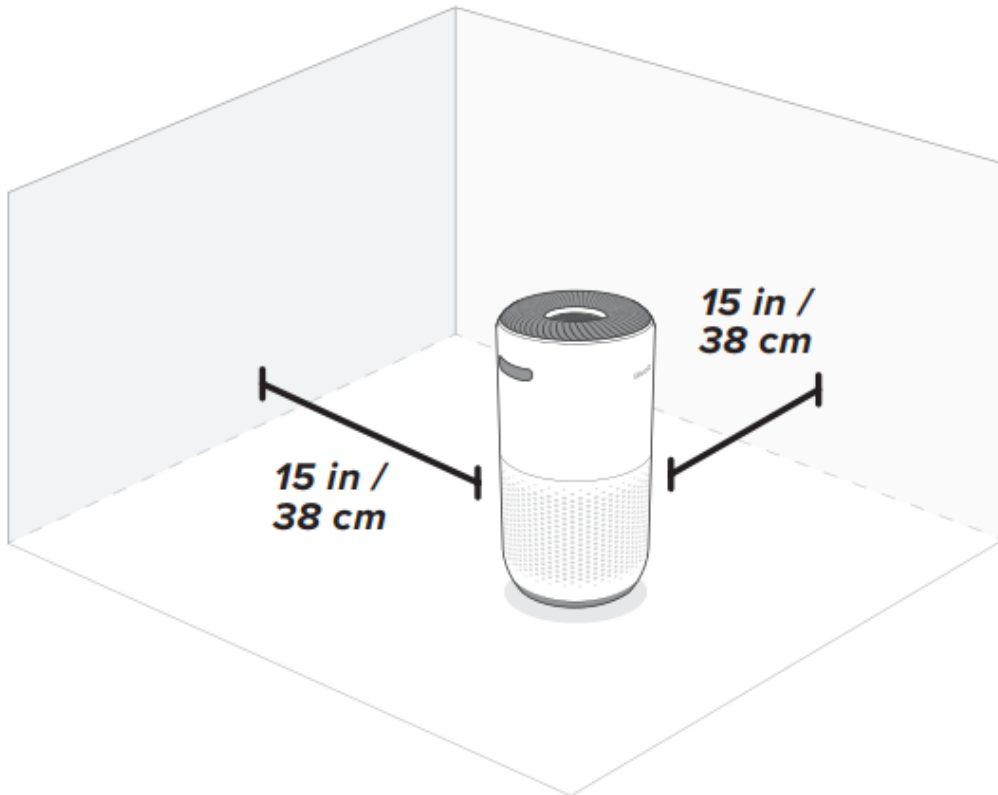

VeSync App Setup

1. To download the VeSync app, scan the QR code or search “VeSync” in the Apple App Store® or Google Play Store.
2. Open the VeSync app. Log In or Sign Up.
3. Follow the in-app instructions to set up your smart air purifier.



Connect with Amazon Alexa or Google Assistant

You can use the VeSync app to connect your smart air purifier to Amazon Alexa or Google Assistant™. Please follow the in-app instructions to set up your voice assistant.

Note: You must create your own VeSync account to access voice assistants.

USING YOUR SMART AIR PURIFIER

Note: Using the VeSync app allows you to control your air purifier remotely and access additional functions and features.

1. Plug in and tap  to turn on the air purifier. The fan will start on low speed.

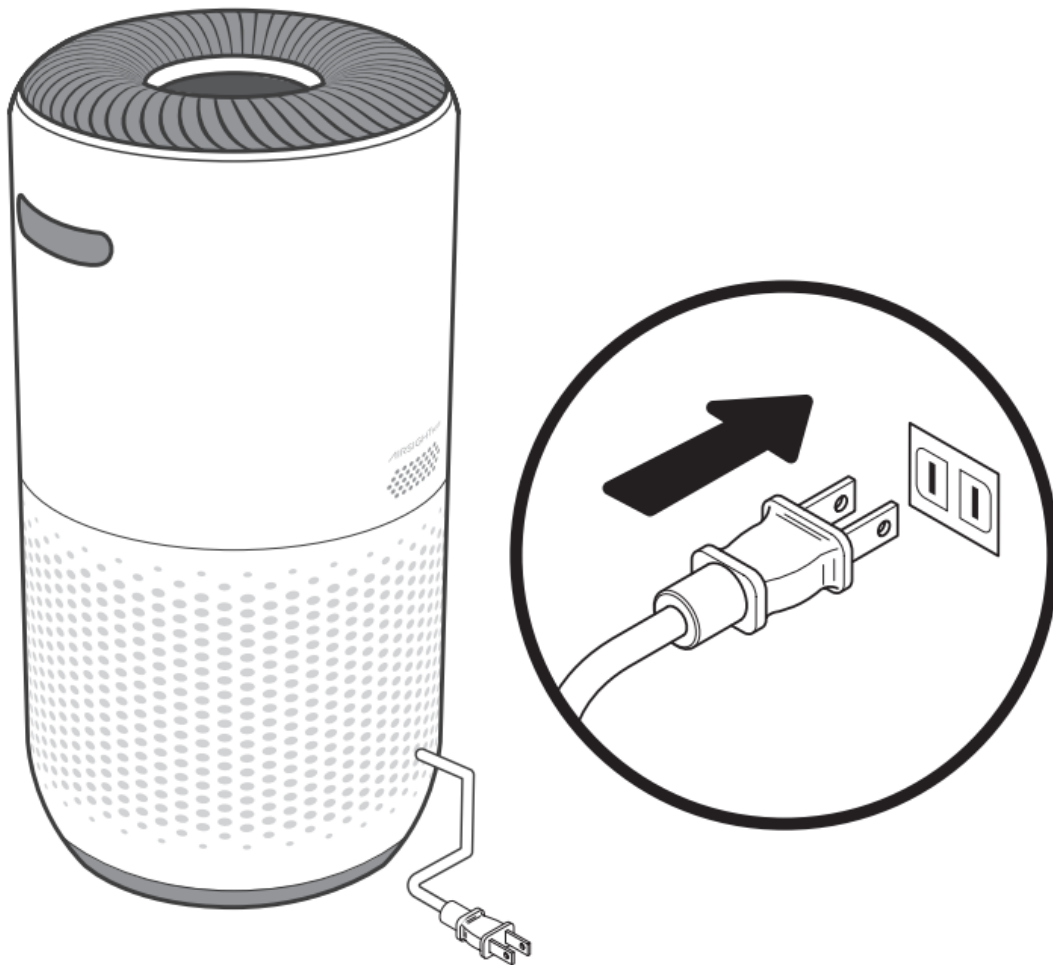

2. Optionally, tap  to change fan speed between low, medium, high, and turbo.

Note:

- The fan speed indicators will light up when active. 1 indicator will light up for low, 2 for medium, 3 for high, and 4 for turbo.
- Turbo speed is the loudest, but cleans air the quickest.

- For best results, or to address a specific air quality issue such as smoke, run the air purifier at turbo speed for 15–20 minutes before using a lower speed.
- To effectively clean air, keep windows and doors closed while the air purifier is on.

3. Tap  to turn off the air purifier.

Sleep Mode

Sleep Mode operates quietly by using a fan speed lower than low speed.

1. Tap  to turn Sleep Mode on/off.
2. Sleep Mode will turn off the display after seconds if no other buttons are tapped.

Note:

- When the display is turned off, tap any button (except ) to turn the display back on. If you don't tap another button, the display will turn off again after 3 seconds.
- The Check Filter Indicator will still turn on and stay on if it's time to check your filter

Auto Mode

Auto Mode uses AirSight™ Plus, a smart laser dust sensor inside the air purifier, to adjust the fan speed automatically based on air quality. For example, if the air quality is bad, the fan will automatically be set to high speed.

Note:

- The air purifier will take 5 seconds to detect the air quality each time it is turned on. During this time, the air quality indicator rings will be blue. After 5 seconds, the air quality indicator rings will change color based on the detected air quality.
- Auto Mode does not use the turbo fan speed.
- The VeSync app also supports additional auto modes: Quiet Auto Mode and Efficient Auto Mode

The PM2.5

The PM2.5 value on the display shows the amount of airborne particles (μg) that are detected per 1 cubic meter (m^3) of air volume.

PM2.5 refers to particulate matter (PM) that is less than or equal to 2.5 microns (μm) in diameter. These particles, also known as "fine particles", are so small that they can only be detected with an electron microscope, and they stay in the air longer than heavier particles such as dust and mold.

Your air purifier's AirSight Plus Laser Dust Sensor detects the amount of PM2.5 particles that are in a given space ($\mu\text{g}/\text{m}^3$). Generally, the lower the number, the better your air quality.

A number above 115 indicates that there is an unhealthy amount of fine particles in the air.

Air Quality Indicator Chart			
Indicator Color	Air Quality	Auto Mode Fan Speed	PM 2.5 Range
Blue	Very Good	Sleep Mode	0–35 ug/m ³
Green	Good	Low	36–75 ug/m ³
Orange	Moderate	Medium	76–115 ug/m ³
Red	Bad	High	> 115 ug/m ³

Timer



You can set a timer for 1–12 hours.

1. Tap . The display will switch from showing the PM2.5 reading to the time you've selected.
2. Tap repeatedly to select a time in hour increments. If you don't touch any buttons for 5 seconds, the display will switch to showing the PM2.5 reading and the timer will start automatically.

Note: Press and hold  for 2 seconds to cycle through timer options automatically in hour increments.

3. The timer will count down from your selected time.

Note:





- While a timer is active, tapping  will show the remaining time, rounded up to the nearest hour. Tap  again within seconds to add more time in 1-hour increments.
 - You can see the exact remaining time in the VeSync app.
4. When the timer is finished, the air purifier will turn off.
 5. To cancel a timer, tap repeatedly until the display reads "--H".

Note:

- You can change the fan speed at any time while the timer is on.
- The timer will restart if the time is changed.
- The air purifier will remember the last timer setting while turned off, but the timer will be cancelled and need to be restarted.
- You can set a timer for 1–24 hours in the VeSync app.

Display Off





This turns off the display lights on the air purifier, including button lights and indicator lights (except the Check Filter Indicator).

1. Tap  to turn off the display.
2. Tap any button (except  or ) to temporarily turn the display back on. If you don't tap another button, the display will turn back off after 3 seconds.
3. Tap  to turn the display back on. The display will stay on.

Note: The Check Filter Indicator will still turn on and stay on if it's time to check your filter.

Display Lock

When the air purifier is on, you can lock the display to prevent settings from being accidentally changed. Buttons will not respond to being tapped.

1. Press and hold  for 3 seconds to lock the display. The  indicator will light up in the center of the display.
 - **Note:** If the display is turned off, the indicator will flash 3 times to show that the display has been locked, then turn off.
2. The  indicator will blink when any other button is tapped to indicate that Display Lock is on.
3. Tap and hold  again for 3 seconds to unlock the display. The  indicator will turn off.

Note:

- If the display is turned off, the  indicator will flash 3 times to show that the display has been unlocked.
- Display Lock can still be used when the air purifier is in Standby Mode

Standby Mode

The air purifier is in Standby Mode when it is turned off, but plugged in.

Note: Display Lock can be used while the air purifier is in Standby Mode to keep the air purifier from being turned back on. The laser dust sensor will still detect the surrounding air quality and give you updates in the VeSync app.

Memory Function

When the air purifier is plugged in and turned off, it will remember its previous fan speed, Sleep Mode, Auto Mode, Display Lock, and Display Off settings.

When the air purifier is unplugged and turned off, it will only remember its previous fan speed, Sleep Mode, and Auto Mode.

Note: The air purifier will remember the last timer setting chosen (1–12 hours), but it will not automatically resume the timer. You will need to restart the timer after the air purifier is turned back on.

VeSync App Functions

The VeSync app allows you to access additional smart air purifier functions, including those listed below. As the app develops, more features may become available.

Remote Control

- Change any air purifier settings through the app, even while Display Lock is on.

Timer Function

Air Quality Updates

- View real-time PM2.5 updates in the app.
- See your air quality history for the previous week.

Auto Mode

- Access additional Auto Modes: Quiet Auto Mode and Efficient Auto Mode.
- Quiet Auto Mode uses medium fan speed instead of the high or turbo fan speeds, even when the air quality is poor, to avoid making too much noise.
- Efficient Auto Mode lets you choose the size of the area you want to purify. The air purifier will use the highest fan speed (turbo) to clean the air for a designated amount of time. This time is based on ACH 1 and the size of the room, meaning how long it takes for the air purifier to clean all the air in your room one time, regardless of the air quality. After this, the mode will adjust the fan speed according to the actual detected air quality in the room.

Note: Efficient Auto Mode is useful for purifying odors from the air. The air purifier's sensor can only detect particles in the air, not smells. Efficient Auto Mode does not rely on the sensor, but the room size instead.

Schedules

- Create and customize schedules for your air purifier to match your routines.

Set a timer between 1–24 hours.

Timer Function

- Set a timer between 1–24 hours.
- Easily view the exact time remaining on a timer.

Filter Replacement Info



- Keep tabs on the remaining filter life by checking the filter life percentage in the app.
- Shop for replacement filters.

CARE & MAINTENANCE

Cleaning the Smart Air Purifier

- Unplug before cleaning.
- Wipe the outside of the air purifier with a soft, dry cloth. If necessary, wipe the housing with a damp cloth, then immediately dry.
- Vacuum the inside of the air purifier.
- Do not clean with abrasive chemicals or flammable cleaning agents.

Check Filter Indicator

 will light up as a reminder to check the filter. Depending on how often you use the air purifier, the indicator should turn on at about 12 months. You may not need to change your filter yet, but you should check it when  turns on.

When your air purifier is set up with the VeSync app, you can also check the app to see your remaining filter life. You will also receive a notification from VeSync when it's time to check your filter.

The VeSync app uses a scientific algorithm to determine your filter life based on air quality, amount of use, and other factors. The filter life percentage is based on 12 hours of daily use.

Filter	When to Clean	How to Clean	When to Replace
Pre-Filter	Every 2–4 weeks	Use a soft brush or vacuum hose	12 months
True HEPA & Activated Carbon Filter	Do not clean		



Cleaning the Filter

The outer pre-filter should be cleaned every 2–4 weeks to increase efficiency and extend the life of your filter. Clean the pre-filter using a soft brush or vacuum hose to remove hair, dust, and large particles. Do not clean the filter with water or other liquids.



Resetting the Check Filter Indicator

Reset the Check Filter Indicator when:

A. lights up red.

1. Replace the filter
2. Turn on the air purifier.
3. Press and hold the  button for seconds.
4.  will turn off when successfully reset.

B. The filter was changed before lit up.

1. Press and hold the  button for seconds.
2. The  will flash for 3 seconds.
3.  will turn off when successfully reset.

When Should I Replace the Filter?

The filter should be replaced every 12 months. You may need to replace your filter earlier or later depending on how often you use your air purifier. Using your air purifier in an environment with relatively high pollution may mean you will need to replace the filter more often, even if  is off.

You may need to replace your filter if you notice:

- Increased noise when the air purifier is on
- Decreased airflow
- Unusual odors
- A visibly clogged filter

Note:

- To maintain the performance of your air purifier, only use official Levoit filters. To buy replacement filters, visit Levoit's online store. Go to levoit.com for more information.
- Remember to reset  after changing the filter

Cleaning the AirSight Plus Laser Dust Sensor

The AirSight Plus Laser Dust Sensor can be blocked by dust, which affects the sensor's accuracy. Clean the sensor every 3 months.

Using your air purifier in an environment with more dust may mean you will need to clean the sensor more often.

1. Unplug the air purifier.
2. Place the end of a vacuum cleaner over the sensor openings. [Figure 3.3]
3. Turn the vacuum on for at least 10 seconds to clean out dust

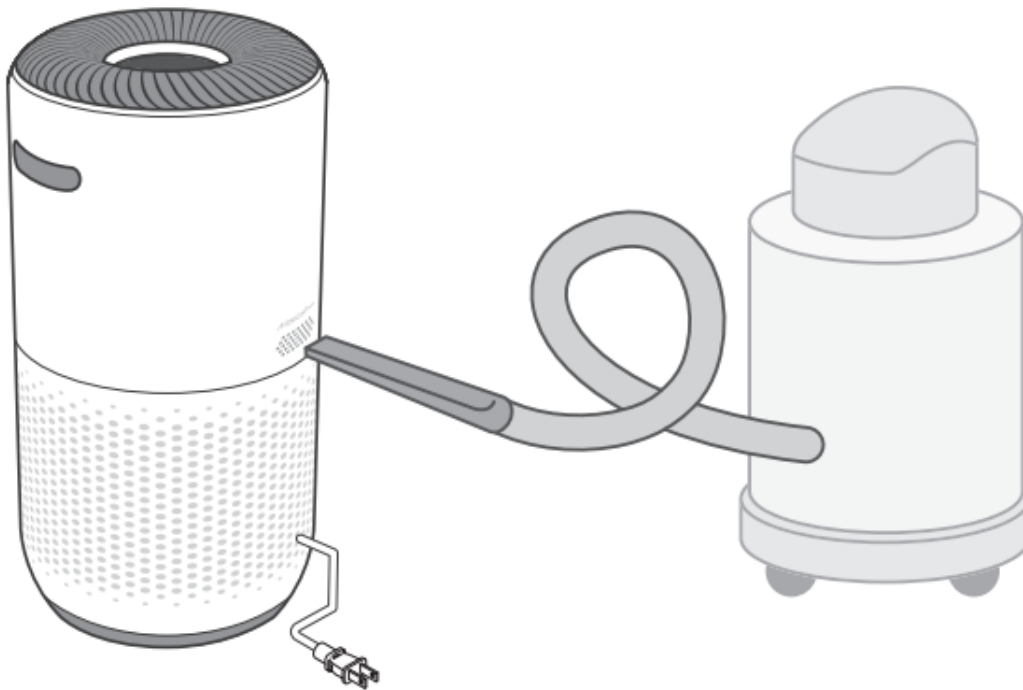

Figure 3.3

Replacing the Filter

1. Unplug the air purifier. Flip the air purifier over or turn it on its side. Remove the filter cover (see Getting Started, page 6).
2. Remove the old filter.
3. Clean out any remaining dust or hair inside the air purifier using a vacuum hose. Do not use water or liquids to clean the air purifier. [Figure 3.2]
4. Unwrap the new filter and place it into the housing
5. Replace the cover. Plug in the air purifier.
6. Reset the Check Filter Indicator

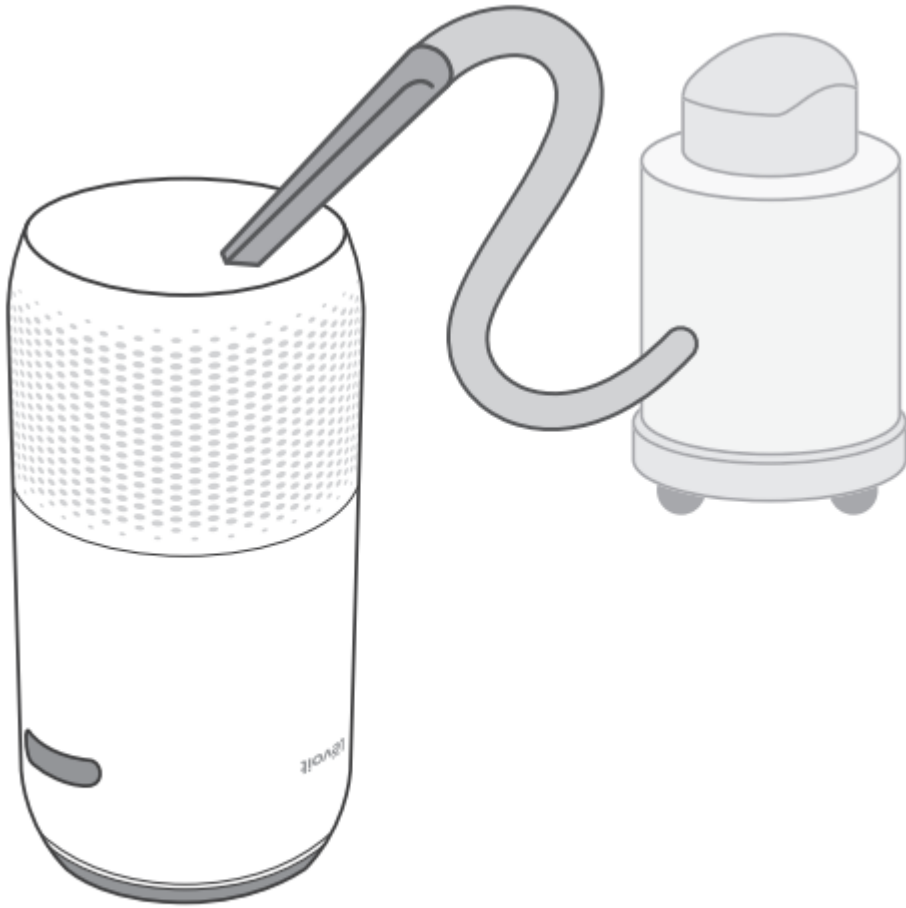











Figure 3.2

TROUBLESHOOTING



Problem	Possible Solution
<p>Air purifier will not turn on or respond to button controls.</p>	<p>Plug in the air purifier.</p> <p>Check to see if the power cord is damaged. If it is, stop using the air purifier and contact Customer Support.</p> <p>Plug the air purifier into a different outlet.</p> <p>The air purifier may be malfunctioning. Contact Customer Support.</p>
<p>Airflow is significantly reduced.</p>	<p>Make sure the filter is removed from its packaging and properly in place.</p> <p>Tap  to increase the fan speed.</p> <p>Leave 15 inches / 38 cm of clearance on all sides of the air purifier.</p> <p>The pre-filter may be clogged by large particles, such as hair or lint, blocking airflow. Clean the pre-filter.</p> <p>Replace the filter.</p>
<p>Air purifier makes an unusual noise while the fan is on.</p>	<p>Make sure the filter is properly in place with plastic packaging removed.</p> <p>Make sure the air purifier is operating on a hard, flat, level surface. Replace the filter.</p> <p>The air purifier may be damaged, or a foreign object may be inside. Stop using the air purifier and contact Customer Support. Do not try to repair the air purifier.</p>

Problem	Possible Solution
<p>Strange smell coming from the air purifier.</p>	<p>Clean the filter, or replace if necessary.</p> <p>Contact Customer Support.</p> <p>Make sure not to use your air purifier in an area with high humidity or while diffusing essential oils.</p>
<p>Poor air purification quality.</p>	<p>Tap  to increase the fan speed.</p> <p>Make sure no objects are blocking the sides or top of the air purifier (the inlet or outlet).</p> <p>Make sure the filter is removed from its packaging and properly in place.</p> <p>Close doors and windows while using the air purifier.</p> <p>If the room is larger than 403 ft² / 37 m², air purification will take longer. The air purifier may not be as effective in significantly larger rooms.</p> <p>Replace the filter.</p>
<p> is still on after replacing the filter.</p>	<p>Reset the Check Filter Indicator.</p>
<p> has not turned on within 12 months.</p>	<p> is a reminder for you to check the filter and will light up based on how much the air purifier has been used. If you don't use your air purifier often,  will take longer to turn on.</p>
	<p> is a reminder for you to check the filter and will light up based on</p>

Problem	Possible Solution
 turned on before 12 months.	how much the air purifier has been used. If you run your air purifier frequently,  will turn on sooner.
Air Quality Indicator always stays red.	<p>The AirSight Plus Laser Dust Sensor may need to be cleaned</p> <p>If you're using an ultrasonic humidifier near the air purifier, the mist may affect the accuracy of the AirSight Plus Laser Dust Sensor.</p> <p>The sensor will detect the large mist particles, and the Air Quality Indicator may turn red. Avoid using an ultrasonic humidifier near the air purifier, or avoid using Auto Mode.</p>
Air Quality Indicator always stays blue, even when the air quality is poor.	<p>The AirSight Plus Laser Dust Sensor detects airborne particles, but it cannot detect gas. Make sure there isn't gas polluting the air.</p>
Display shows Error Code "E1".	<p>The motor has malfunctioned. Please contact Customer Support</p>

VESYNC APP TROUBLESHOOTING

My smart air purifier isn't connecting to the VeSync app.

- Make sure your phone has Bluetooth® turned on and is not currently connected to another Bluetooth device.
- During the setup process, you must be on a secure 2.4GHz Wi-Fi® network. Confirm that the network is working correctly.
- Make sure the Wi-Fi password you entered is correct.
 - There should be no spaces at the beginning or end of the password.
 - Test the password by connecting a different electronic device to the router.

- If you're manually typing in the SSID and password, double check that both are entered correctly.
- Try moving your air purifier closer to the router. Your phone should be as close as possible to your air purifier.
- Your router may need to be at a higher location, away from obstructions.
- Make sure your air purifier and router are away from appliances (such as microwave ovens, refrigerators, electronic devices, etc.) to avoid signal interference.
- If you're using a VPN, make sure it's turned off while setting up your air purifier.
- Disable portal authentication for your Wi-Fi network. If portal authentication is enabled, the air purifier will not be able to access your Wi-Fi network, and setup will fail.

Note: Portal authentication means that you need to sign in to your Wi-Fi network through a web page before you can use the Internet.

My air purifier is offline.

- Make sure the air purifier is plugged in and has power, then refresh the VeSync menu by swiping down on the screen.
- Make sure your router is connected to the internet and your phone's network connection is working.
- Delete the offline air purifier from the VeSync app. Swipe left (iOS®) or press and hold (Android™), then tap Delete. Reconfigure the air purifier with the VeSync app.

Note: Power outages, internet outages, or changing Wi-Fi routers may cause the air purifier to go offline

Warning

This content is compiled from multiple sources and is provided for reference purposes only. It may not be complete or fully applicable to all situations. If you are unable to resolve your issue, please contact the product manufacturer or an authorized service provider for official support.