

## User Manual

# About Your RoboVac

## RoboVac Anatomy

### What's in the Box

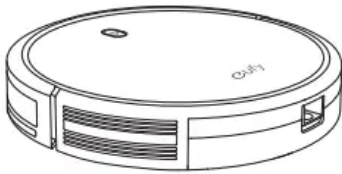

RoboVac



Charging Base

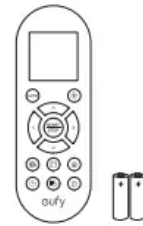

Remote Control  
(AAA Battery x2)

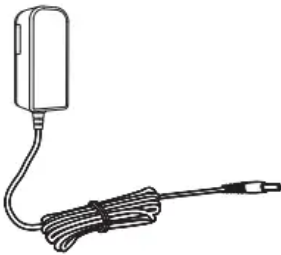

Power Adapter

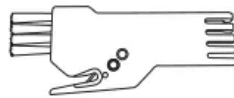

Cleaning Tool

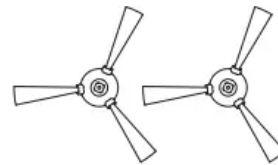

Side Brushes (x4)



Additional  
High-Performance  
Filter

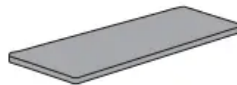

Additional  
Foam Filter



Owner's Manual &  
Other Documents

## Top & Side

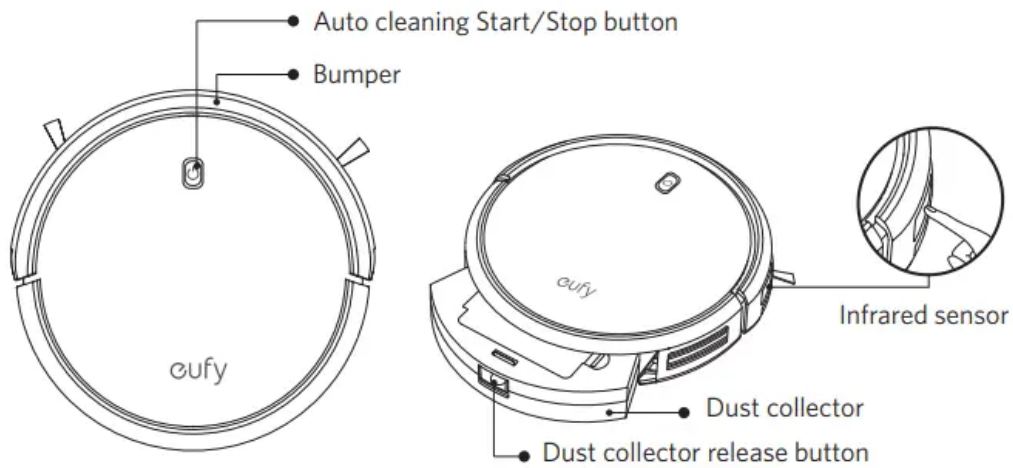

**Bottom**

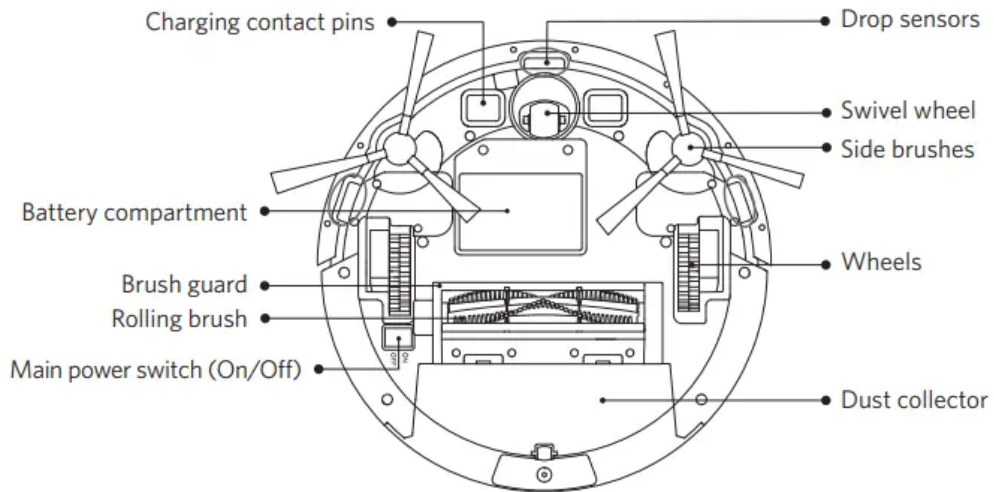

**Dust Collector**

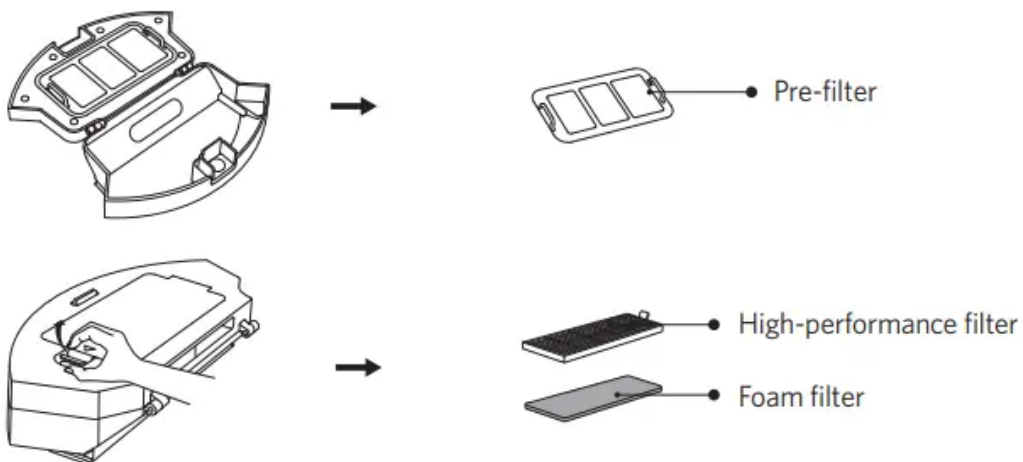

**Suction Inlet**



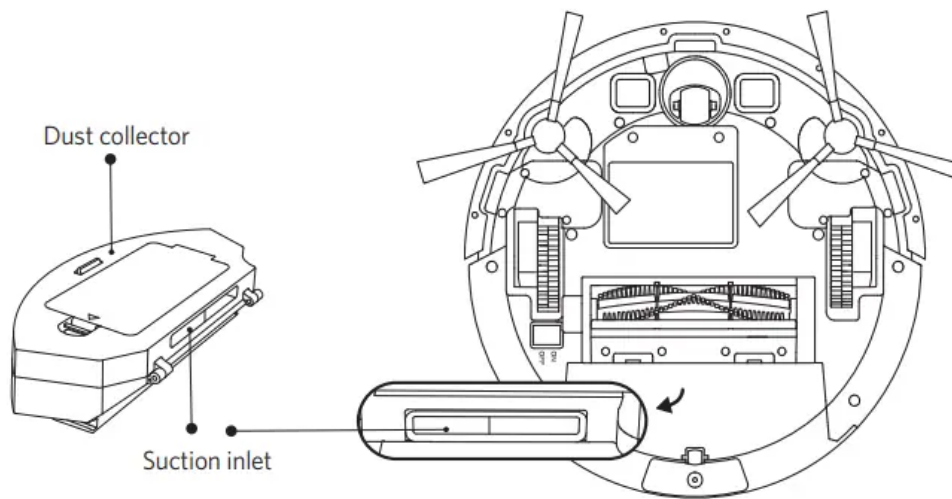

## Charging Base

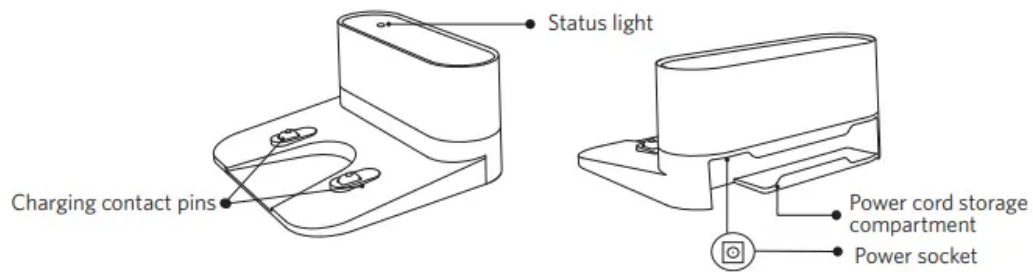

## Remote Control

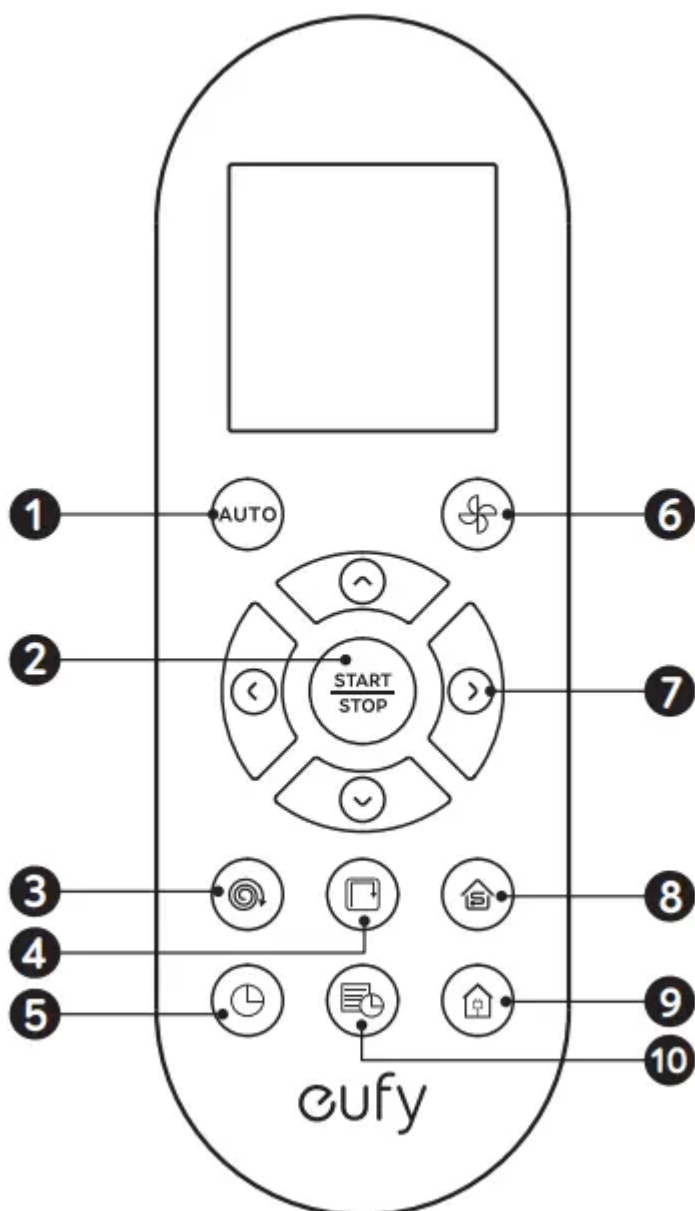

1. Start Auto cleaning
2. Stop cleaning
3. Start Spot cleaning
4. Start Edge cleaning
5. Adjust time
6. Adjust suction power level in Auto/Single Room Cleaning mode
7. Control cleaning direction manually Adjust the hour and minute
8. Start Single Room cleaning
9. Return RoboVac to Charging Base
10. Schedule Auto cleaning start time

## Remote Control Display

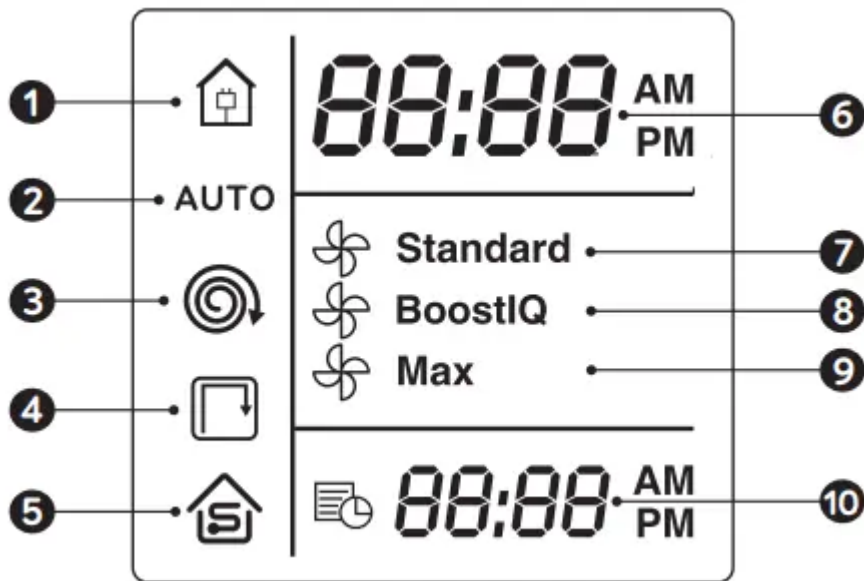

1. Returning to Charging Base
2. Auto cleaning mode selected
3. Spot cleaning mode selected
4. Edge cleaning mode selected
5. Single Room cleaning mode selected
6. Clock
7. Standard suction power enabled
8. BoostIQ™ dynamic suction power enabled
9. Max suction power enabled
10. Scheduled cleaning time

### LED Indication

You can see the status of RoboVac from the LED indicator.

⏻ (Status Light)	Status
Breathing orange	Charging
Solid blue	Standby / Cleaning / Fully charged
Solid orange	Low power and returning to Charging Base
Off	<ul style="list-style-type: none"> <li>• RoboVac is off.</li> <li>• To conserve power, the light automatically turns off when RoboVac is not docked to the Charging Base and has been inactive for 1 minute.</li> </ul>
Flashing / Solid red + Beeping	RoboVac has an error. Refer to the " <b>Troubleshooting&gt;Error Tone</b> " section in this manual for solutions.

## Using Your RoboVac

### Important Tips Before Use

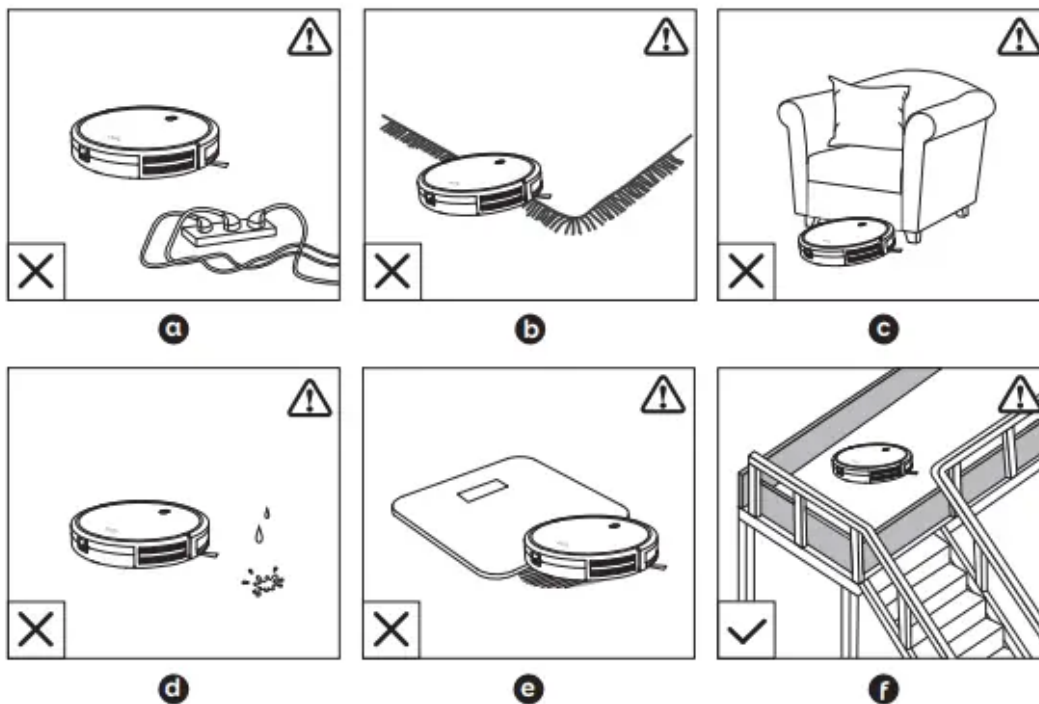

a Remove power cords and small objects from the floor that may entangle RoboVac.

b Fold tasseled edges of area rugs underneath to prevent tangling RoboVac. Avoid cleaning very dark-colored high-pile rugs or rugs thicker than 1.02 in/26 mm as they may cause RoboVac to malfunction.

c Keep RoboVac away from spaces lower than 2.87 in/73 mm to prevent RoboVac from getting stuck. If necessary, place a physical barrier to block off the problem areas.

d Keep RoboVac away from wet areas.

e RoboVac may climb on top of objects less than 0.63 in/16 mm in height. Remove these objects if possible.

f Anti-drop sensors prevent RoboVac from tumbling down stairs and steep drops. They may work less effectively if dirty or used on reflective/very dark-colored floors. It is recommended to place physical barriers to block off areas where RoboVac may fall.

## Preparation

1. Install the side brushes before use.

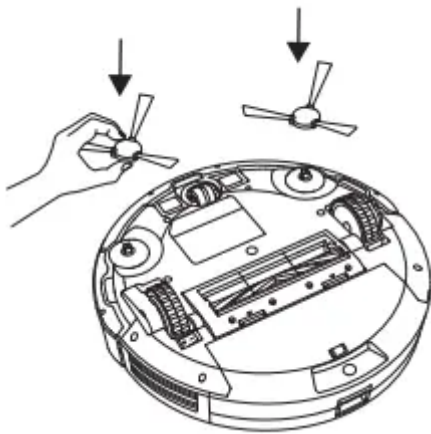

2. Turn on the main power switch on the bottom of RoboVac.3

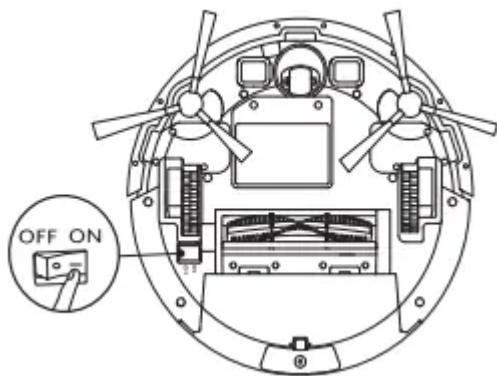

3. Place the Charging Base on a hard, level surface and against a wall.

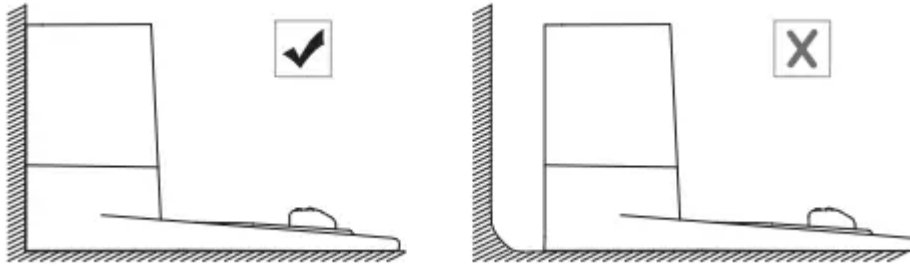

4. Remove objects within 3 ft/1 m of the left and right side and within 6 ft/2 m of the front of the charging base.

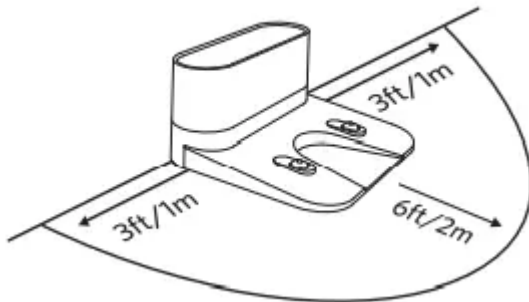

5. Connect the round connector of the adapter into the power socket on the Charging Base and the other end into a wall outlet.

- When the Charging Base connects to AC power, the LED indicator on the Charging Base is SOLID WHITE.

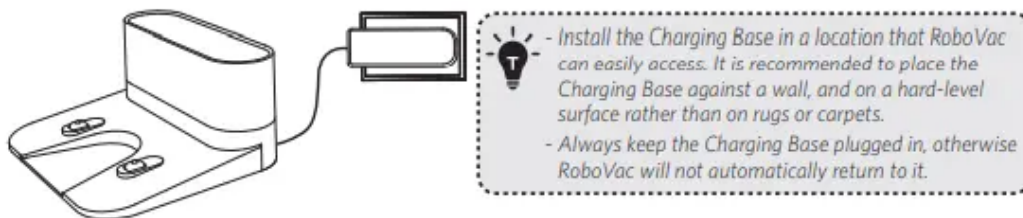

## Charge Your RoboVac

- RoboVac has a pre-installed rechargeable battery that has to be fully charged before use.
- RoboVac returns to the Charging Base at the end of a cleaning cycle or when its battery is running low.

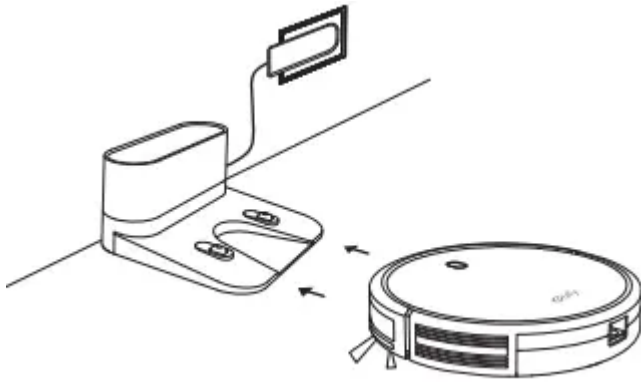

Method 1: Attach RoboVac to the Charging Base by aligning its charging pins with the charging pins on the base.

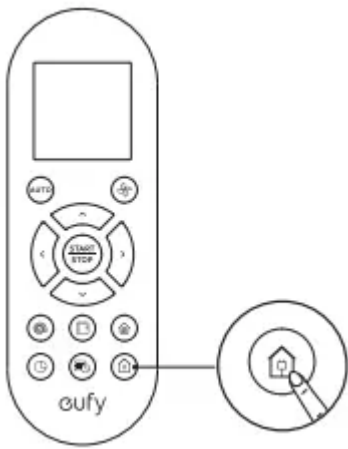

Method 2: Press  on the remote control to return RoboVac to the Charging Base.



### Start / Stop Cleaning

1. Press  on RoboVac or  /  on the remote control to start cleaning in Auto Mode.

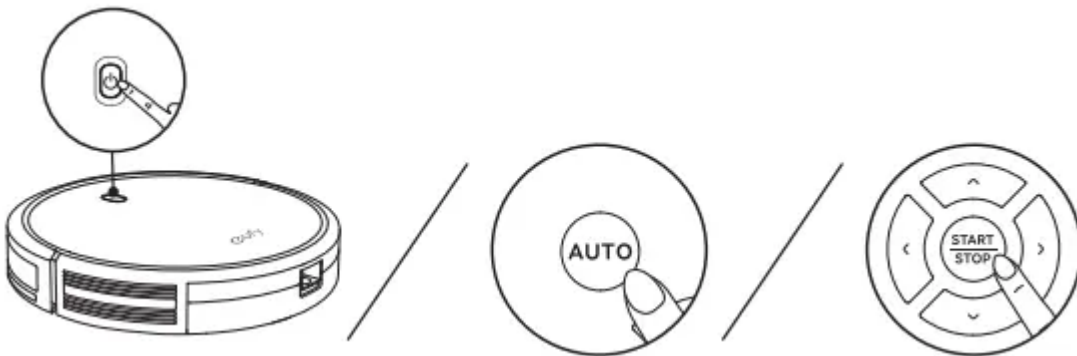

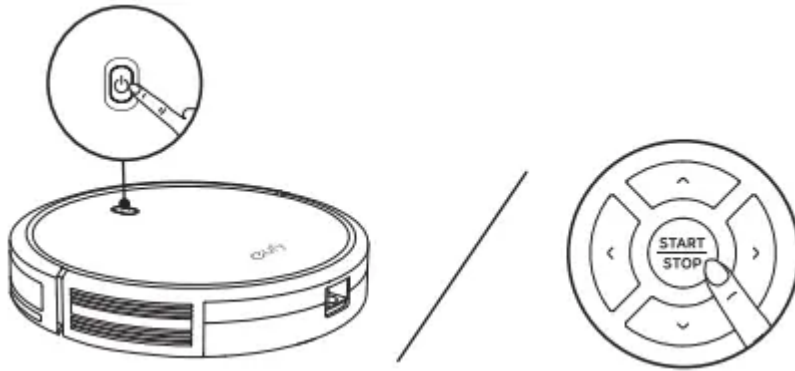

2. Press  on RoboVac or  on the remote control to stop cleaning.



## Select a Cleaning Mode

1. Auto cleaning RoboVac optimizes its cleaning path by selecting different cleaning modes automatically until cleaning is complete. This is the most commonly used cleaning mode.

Press  on RoboVac or  /  on the remote control to start cleaning in Auto Mode.

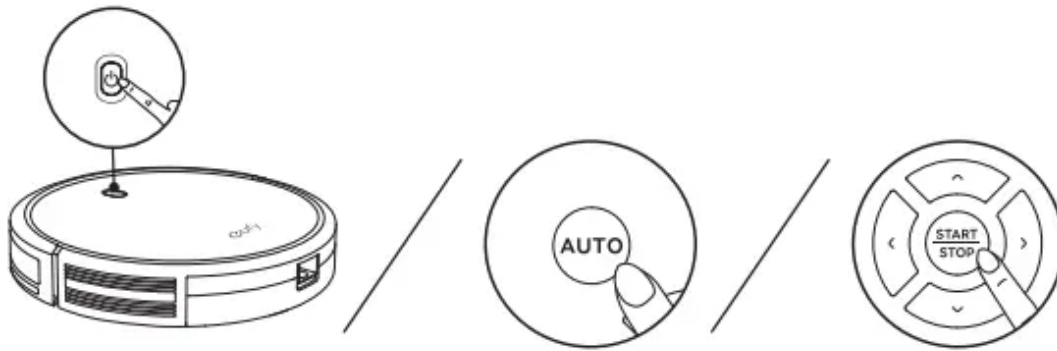



## BoostIQ™ Feature

When the BoostIQ™ feature is enabled, RoboVac will automatically increase the suction power if it detects stronger power is needed to ensure the best clean. BoostIQ™ is ideal for cleaning thicker carpets and hard-to-sweep messes, which will reduce the total cleaning time, but increase the noise level. If the vacuuming noise caused by BoostIQ™ disturbs you, you can disable this feature. This feature only works in Auto and Single Room cleaning modes.

In Auto or Single Room cleaning mode, press  on the remote control repeatedly to adjust the suction power level.

- The corresponding icon is displayed on the remote control.

Icon	Suction Power Level
 <b>Standard</b>	Standard power
 <b>BoostIQ</b>	Automatically switches between Standard and Enhanced power (default)
 <b>Max</b>	Maximum power

## 2. Spot cleaning

RoboVac intensively cleans a specific area in a spiral, useful if there is a concentrated area of dust or debris. In Spot mode, RoboVac will stop cleaning after 2 minutes.

Press  on the remote control to start cleaning in Spot mode.

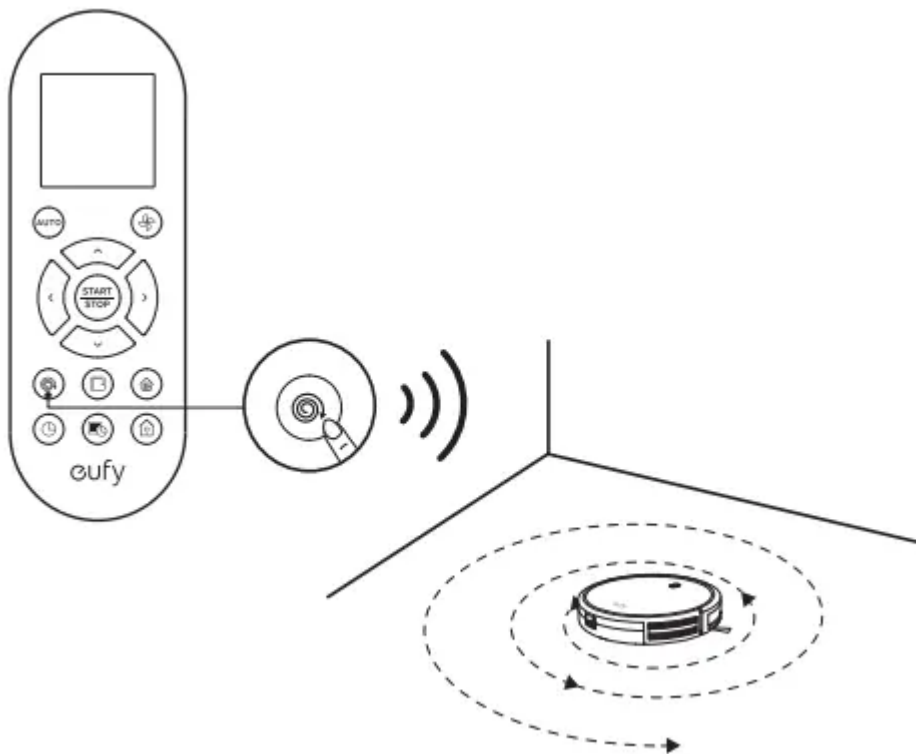

## 3. Edge cleaning

RoboVac reduces its speed when it detects a wall and then follows the wall to ensure the edge is cleaned thoroughly. In Edge mode, RoboVac will clean for 20 minutes and return to the Charging Base.

Press  on the remote control to start cleaning in Edge mode.

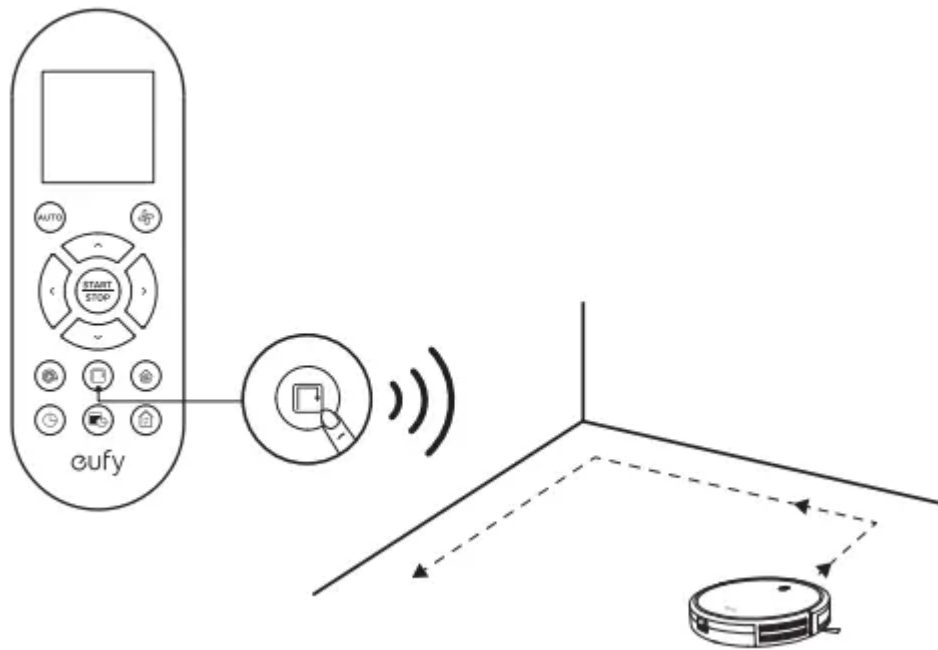

#### 4. Single Room cleaning

RoboVac intensively cleans one single room and stops after 30 minutes. Select this mode only when one specific room needs to be cleaned. Make sure to confine RoboVac to the room by closing the door.

Press  on the remote control to start cleaning in Single Room Mode.

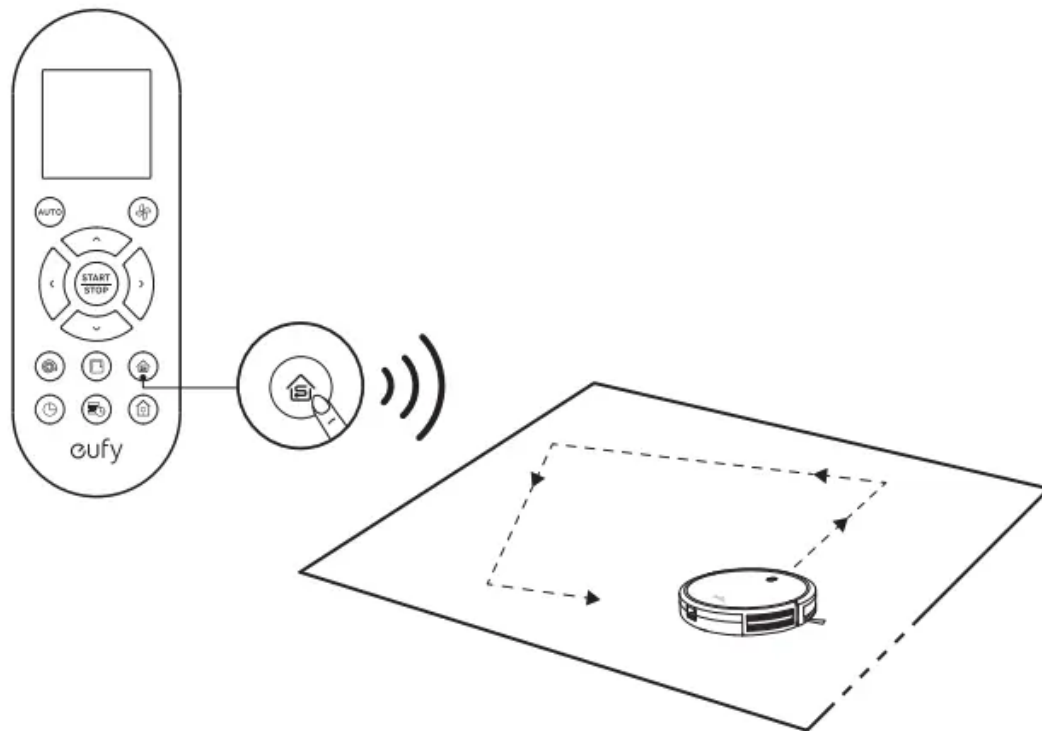

#### 5. Manual cleaning

You can direct RoboVac to clean a particular area by using the directional buttons on the remote control.

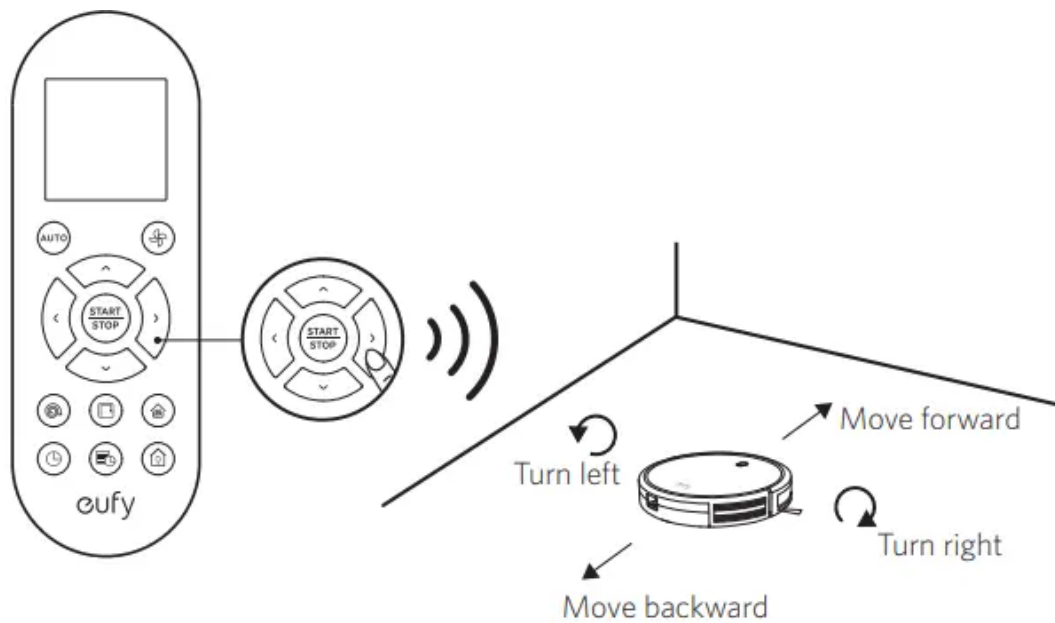





## Set Time and Scheduled Cleaning



### Set Time

1 Make sure the main power switch on the bottom of RoboVac is turned on.

2 Press  on the remote control. The time will blink on the display.

3 Press     to set the "hour" and "minute".

Note: Make sure AM/PM is set correctly.

4 Press  or  to save the setting. RoboVac will BEEP ONCE to indicate the time has been set.

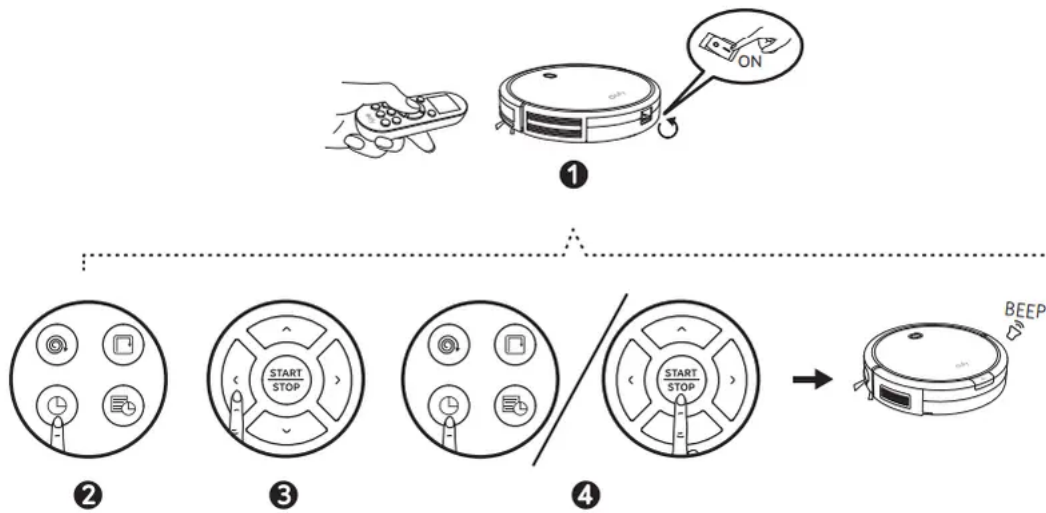

### Set a Scheduled Cleaning

You can schedule RoboVac to start cleaning at a specified time. To cancel a previously scheduled cleaning, press and hold for 3 seconds until RoboVac beeps twice and disappears.

Note: Before setting a scheduled cleaning, make sure the time has been set correctly to your local time; refer to the previous section “Set Time” for how to set the time.

1 Make sure the main power switch on the bottom of RoboVac is turned on.

2 Press on the remote control. will blink on the display

3 Press to set the “hour” and “minute”. Note: Make sure AM/PM is set correctly.

4 Press or to save the setting. RoboVac will BEEP ONCE to indicate the scheule has been set.

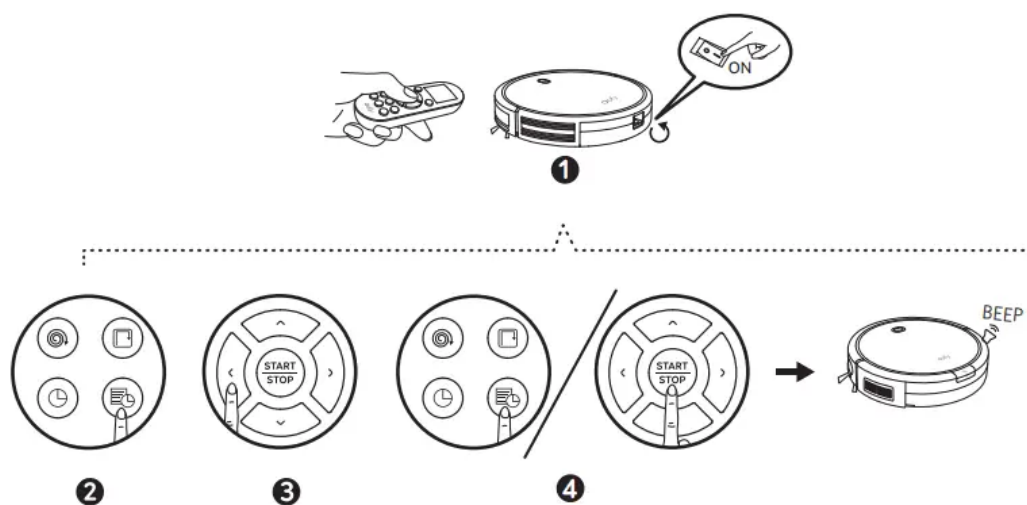

# Cleaning and Maintenance

For optimal performance, follow the instructions below to clean and maintain RoboVac regularly. The cleaning/replacement frequency will depend on your usage habits of RoboVac.

## Recommended cleaning/replacement frequency:

RoboVac Part	Cleaning Frequency	Replacement Frequency
Dust Collector	After each use	-
Filters	Once every week	Every 2 months
Rolling Brush	Once every week	Every 6-12 months
Side Brushes	Once every month	Every 3-6 months (or when visibly worn)
Sensors	Once every month	-
Charging Pins	Once every month	-
Swivel Wheel	Once every month	-

### Clean the Dust Collector and Filters

- 1 Press the dust collector release button to pull the dust collector out.
- 2 Open and empty the dust collector.

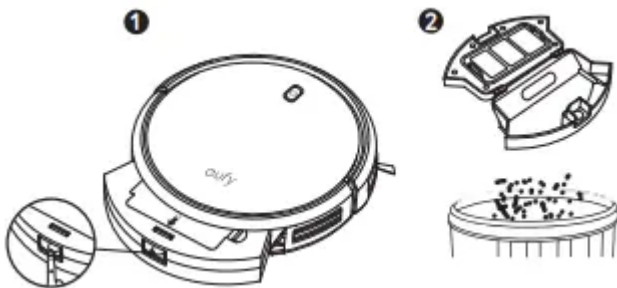

- 3 Remove the pre-filter by pulling the hooks as shown.

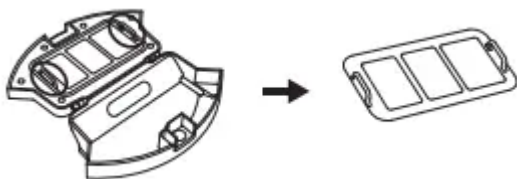

- 4 Take out the foam filter and high-performance filter.

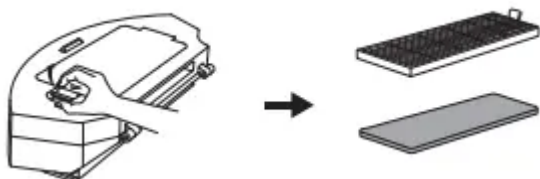

- 5 Clean the dust collector and filters with a vacuum cleaner or a cleaning brush.

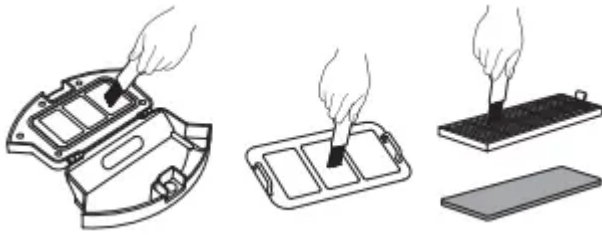

6 Put the filters and pre-filter back together in the dust collector

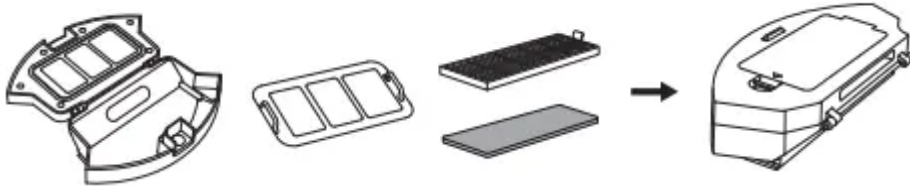

7 Push the dust collector back into the main unit.



### Clean the Rolling Brush

- 1 Pull on the release tabs to unlock the brush guard as shown.
- 2 Lift the rolling brush to remove.
- 3 Clean the rolling brush with the provided cleaning tool or a vacuum cleaner.
- 4 Reinstall the rolling brush by inserting the fixed protruding end first and then clicking into place.
- 5 Press down to snap the brush guard into place.

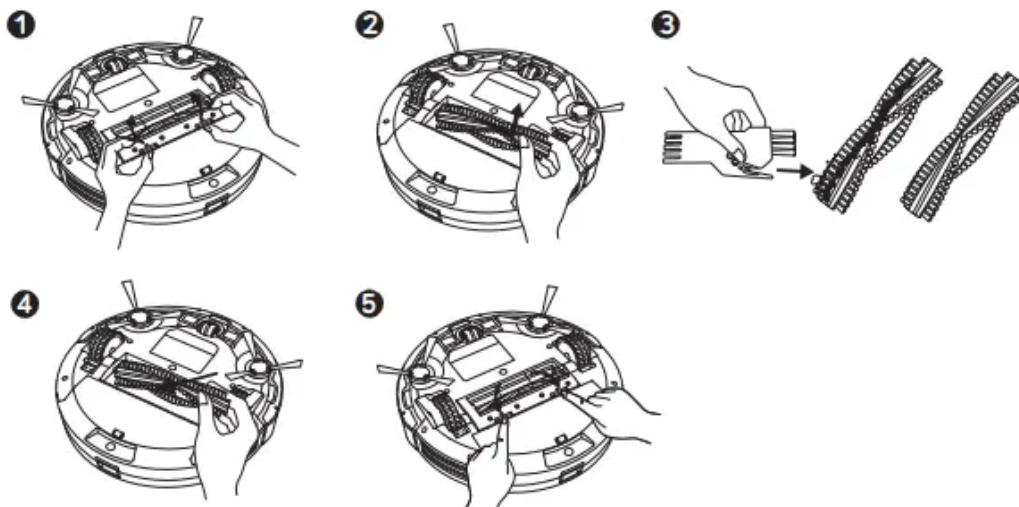

### Clean the Side Brushes

Foreign substances, such as hair, can easily get tangled in the side brushes, and dirt may adhere to them. Be sure to clean them regularly.

1. Remove the side brushes.
2. Carefully unwind and pull off any hair or string that is wrapped between the main unit and the side brushes.
3. Use a cloth dampened with warm water to remove dust from the brushes or to gently reshape them.

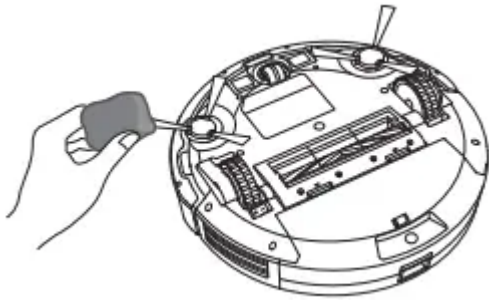

### Replace the Side Brushes

The side brushes may become bent or damaged after being used for a period of time. Follow the instructions below to replace them. Pull off the old side brushes and snap the new ones into place.

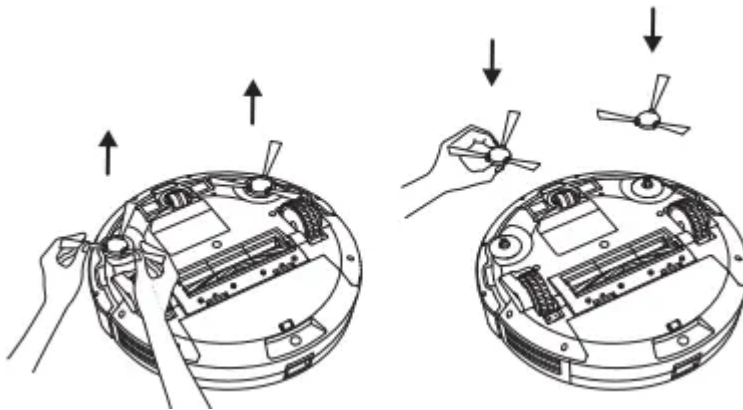

### Clean the Sensors and Charging Pins

To maintain the best performance, clean the drop sensors and charging pins regularly.

- Dust off the drop sensors and charging contact pins using a cloth or cleaning brush.

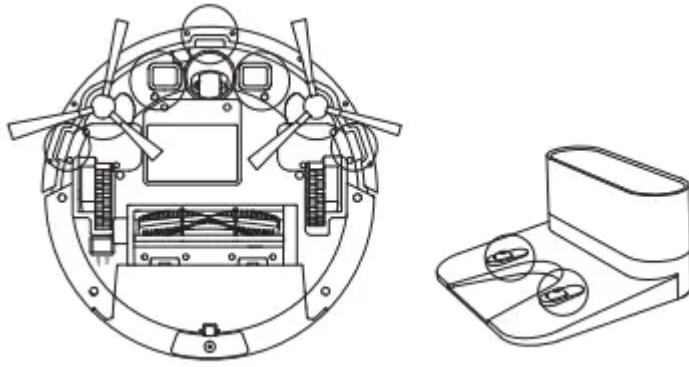

### Clean the Swivel Wheel

Hair or dust particles can easily get entangled in the swivel wheel. Be sure to clean the swivel wheel periodically and as needed.

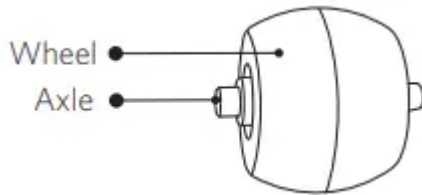

1. Pull out the swivel wheel.
2. Clean any hair or debris wrapped around the wheel or entangled inside the wheel cavity.
3. Reinstall the wheel and push in until it clicks into place

## Troubleshooting

Problems	Solutions
RoboVac cannot be activated.	<ul style="list-style-type: none"> <li>• Make sure the main power switch is in the ON position.</li> <li>• Make sure the battery is fully charged.</li> <li>• Replace the batteries (2 AAA) in the remote control.</li> <li>• Make sure the remote control is within range (16 ft/5 m) of RoboVac.</li> <li>• If you still have trouble, turn off the main power switch and then turn it back on.</li> </ul>
	<ul style="list-style-type: none"> <li>• Replace the batteries in the remote control.</li> </ul>

The remote control does not work.	<ul style="list-style-type: none"> <li>• Make sure RoboVac is turned on and fully charged.</li> </ul>
RoboVac stops working suddenly.	<ul style="list-style-type: none"> <li>• Check if RoboVac is trapped or stuck on an obstacle.</li> <li>• Check if the battery level is too low.</li> <li>• If you still have trouble, turn off the main power switch, wait for 2 seconds, and then turn it back on.</li> </ul>
You cannot schedule cleanings.	<ul style="list-style-type: none"> <li>• Make sure the main power switch on the bottom of RoboVac is turned on.</li> <li>• Make sure the time, time of day (AM/PM), and the scheduled time have been set correctly.</li> <li>• Check if RoboVac's power is too low to start cleaning.</li> </ul>
Suction power is weak.	<ul style="list-style-type: none"> <li>• Check if any obstructions are blocking the suction inlet.</li> <li>• Empty the dust collector.</li> <li>• Clean the filters with a vacuum cleaner or a cleaning brush.</li> <li>• Check if the filters are wet due to water or other liquid on the floor. Air-dry the filters completely before use.</li> </ul>
RoboVac cannot be charged.	<ul style="list-style-type: none"> <li>• Check if the indicator on the Charging Base lights up. If not, contact the eufy service center to repair or replace the Charging Base.</li> <li>• Dust off the charging contact pins with a dry cloth.</li> <li>• Check if you can hear a beep when RoboVac is docked onto the Charging Base. If not, contact the eufy service center to repair or replace the Charging Base.</li> </ul>



<p>RoboVac cannot return to the Charging Base.</p>	<ul style="list-style-type: none"> <li>• Remove objects within 3 ft/1 m to the left and right side and within 6 ft/2 m of the front of the Charging Base.</li> <li>• When RoboVac is in the vicinity of the Charging Base, it will return more quickly. However, if the Charging Base is located far away, RoboVac will need more time to return. Please be patient as it works its way back.</li> <li>• Clean the charging contact pins.</li> </ul>
--	--

Problems	Solutions
The rolling brush does not rotate.	<ul style="list-style-type: none"> <li>• Clean the rolling brush.</li> <li>• Check if the rolling brush and brush guard have been installed properly.</li> </ul>
RoboVac's movements or travel path are abnormal.	<ul style="list-style-type: none"> <li>• Clean the sensors carefully with a dry cloth.</li> <li>• Restart RoboVac by turning the power switch off and on.</li> </ul>

## Error Tones

When RoboVac is in trouble, it will emit a series of short or long beeps and the red indicator on RoboVac will be solid or flashing.

### Flashing red indicator light



Error Tone	Cause	Solution
Two beeps	RoboVac's bumper is stuck.	Tap RoboVac's bumper several times to dislodge any debris that may be trapped underneath.
Three beeps	<ul style="list-style-type: none"> <li>• RoboVac's drop sensors are dirty.</li> <li>• RoboVac is stuck on the</li> </ul>	<ul style="list-style-type: none"> <li>• Clean the drop sensors gently with a dry cloth.</li> <li>• Place RoboVac in a new location.</li> </ul>

	ledge of a staircase and cannot reverse.	<ul style="list-style-type: none"> <li>• Use a physical barrier to block off the problem area.</li> </ul>
Four beeps	RoboVac's power level is too low.	Manually charge RoboVac for at least 5 hours.

### Solid red indicator light

Error Tone	Cause	Solution
One beep	RoboVac's left/right wheel is stuck.	Turn off RoboVac and remove any hair or debris from the left/right wheel.
Two beeps	RoboVac's side brush is stuck.	Turn off RoboVac and remove any hair or debris from the side brush.
Three beeps	RoboVac's suction fan is stuck.	<ul style="list-style-type: none"> <li>• Turn off RoboVac, then remove and empty the dust collector.</li> <li>• Make sure the suction inlet is not blocked by any hair or debris.</li> </ul>
Four beeps	RoboVac's rolling brush is stuck.	Turn off RoboVac and remove any hair or debris from the rolling brush.

### Specifications

	Product Model	T2108/T2109/T2110
	Input	19 V  0.6 A
	Battery Voltage	DC 14.4 V
	Power Consumption	25 W
	Battery Type	DC 14.4 V Li-ion 2600 mAh
	Dust Collector Capacity	0.6 L
	Cleaning Time	Max. 100 mins
	Charging Time	300 - 360 mins

	Input	19 V  0.6 A
	Output	19 V  0.6 A

### Warning

This content is compiled from multiple sources and is provided for reference purposes only. It may not be complete or fully applicable to all situations. If you are unable to resolve your issue, please contact the product manufacturer or an authorized service provider for official support.

---

Document generated by [ManualsFile](#)

