

User and manual Electric Smoker

Parts List

Actual product may differ from picture shown

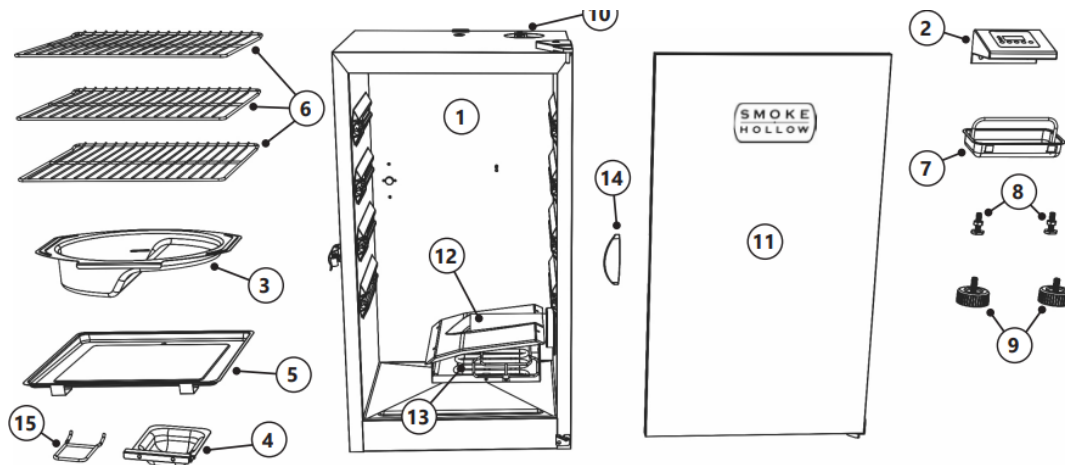

NO	QTY	DESCRIPTION
1	1	Smoker Body
2	1	Digital Control Panel
3	1	Water Bowl
4	1	Wood Chip Tray
5	1	Drip Pan
6	3	Rack
7	1	Grease Tray
8	2	Adjustable Screw Leg
9	2	Leg Boot
10	1	Air Damper (pre-assembled)
11	1	Door (pre-assembled)
12	1	Wood Chip Housing (pre-assembled)
13	1	Element (pre-assembled)
14	1	Door Handle
15	1	Wood Chip Tray Handle

Parts that are preassembled at time of purchase should be ordered separately if replacement is needed



Hardware List



DO NOT RETURN TO RETAILER for assembly assistance, missing or damaged parts. Please contact Smoke Hollow® Customer Service at 1-866-475-5180 or smoke-hollow.com/contact-support. Please have the model number and serial number available. These numbers are located on the silver rating label on the smoker.

- BEFORE ASSEMBLY READ ALL INSTRUCTIONS CAREFULLY.
- Assemble on a clean flat surface.
- Tools needed: Adjustable wrench, Phillips head screwdriver
- Approximate assembly time: 25 minutes
- Actual product may differ from picture shown.
- It is possible that some assembly steps have been completed in the factory

Assembly

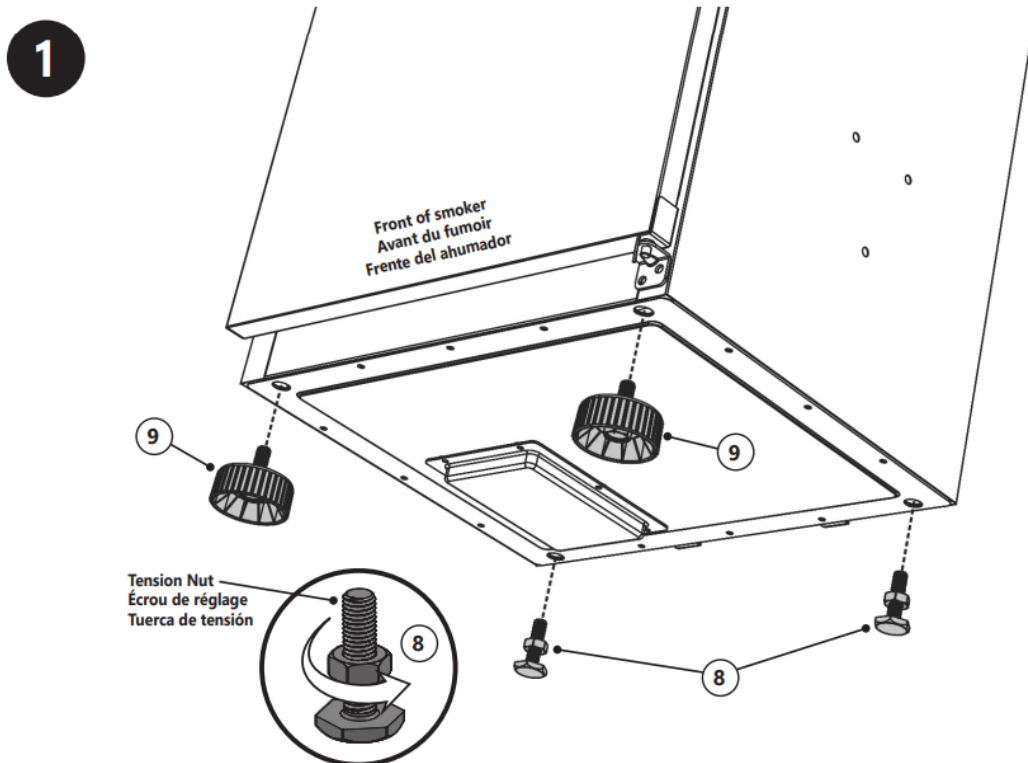

2

Stabilizing Screw
Vis de stabilisation
Tornillo de estabilización

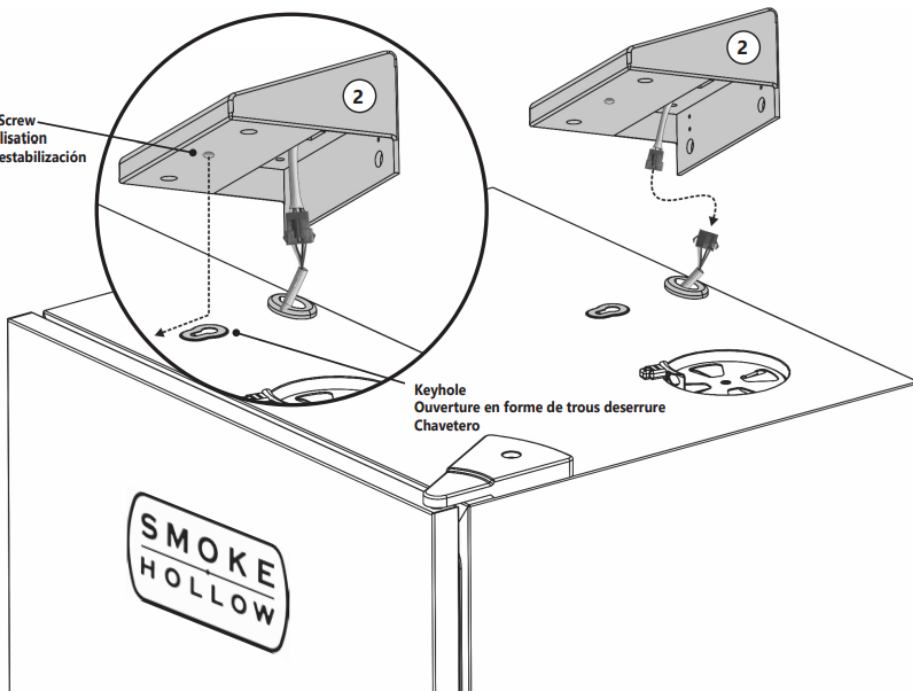

3

A
X2

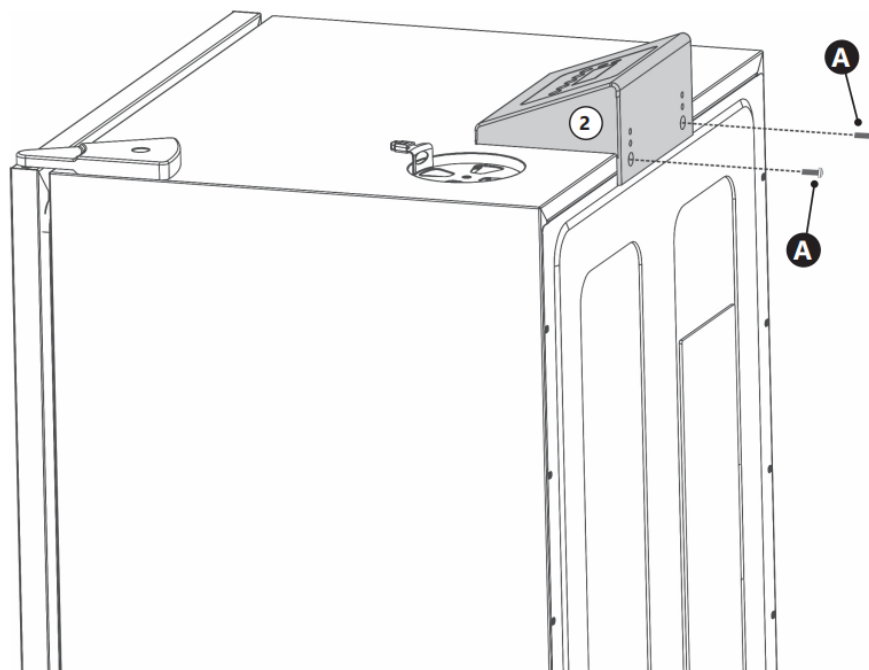

4

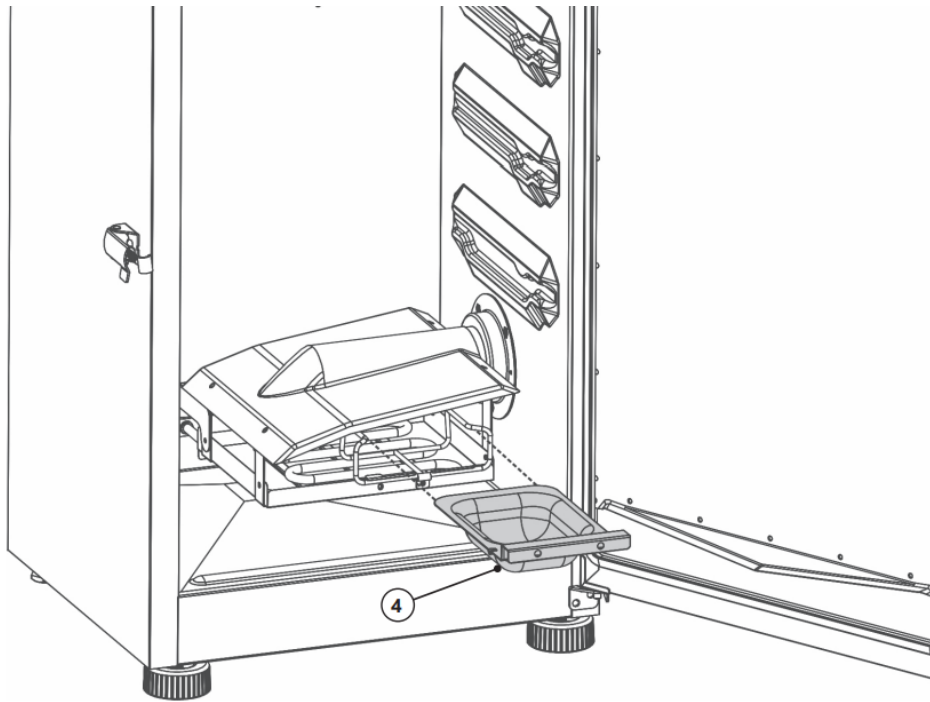

5

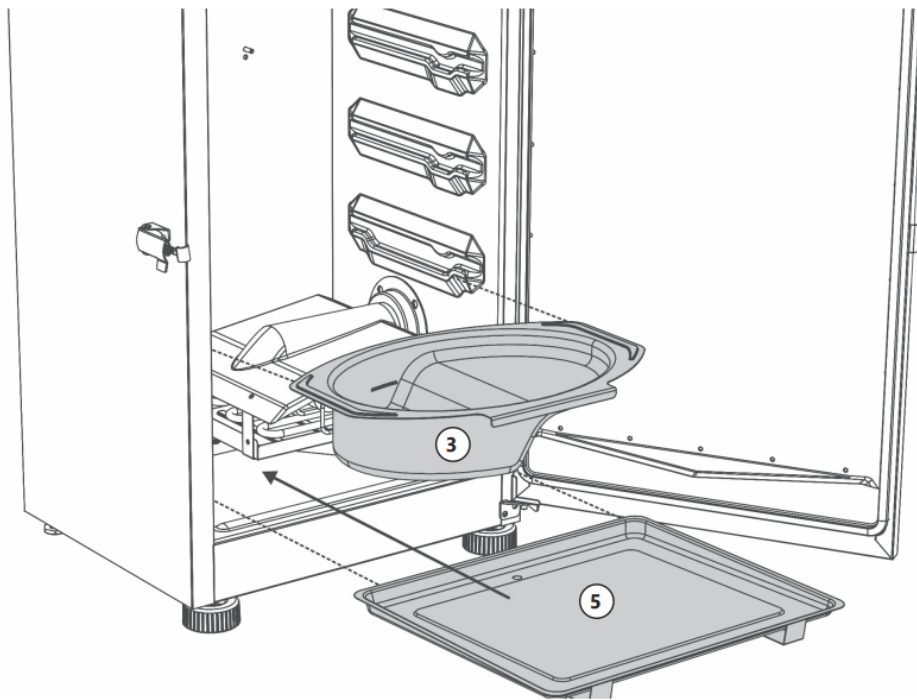

6

B

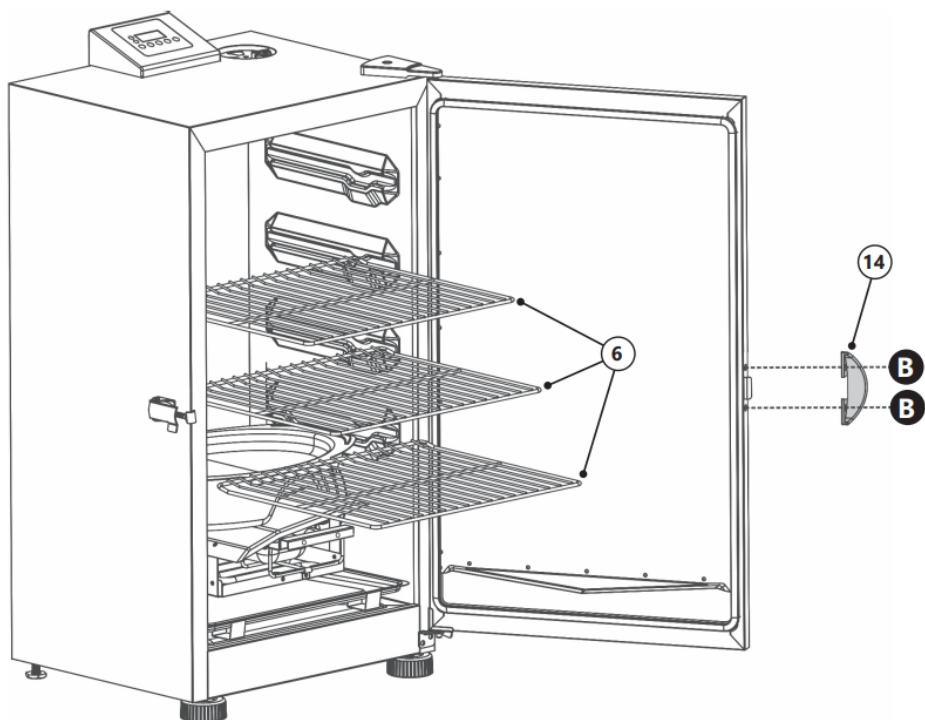

7

Back of smoker
Arrière du fumoir
Parte posterior
del ahumador

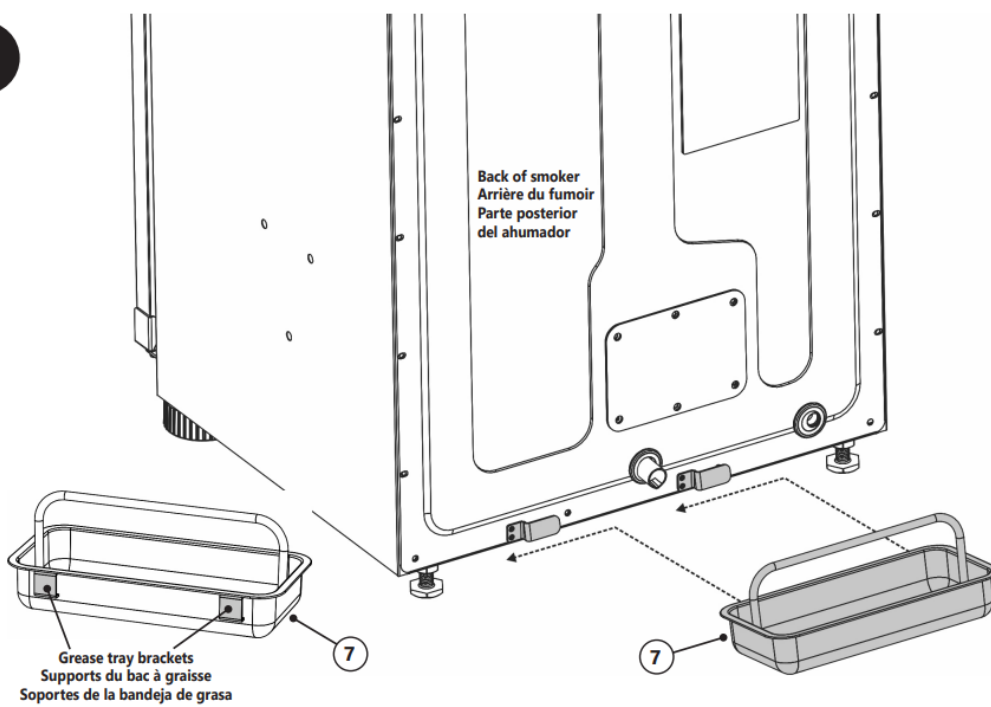



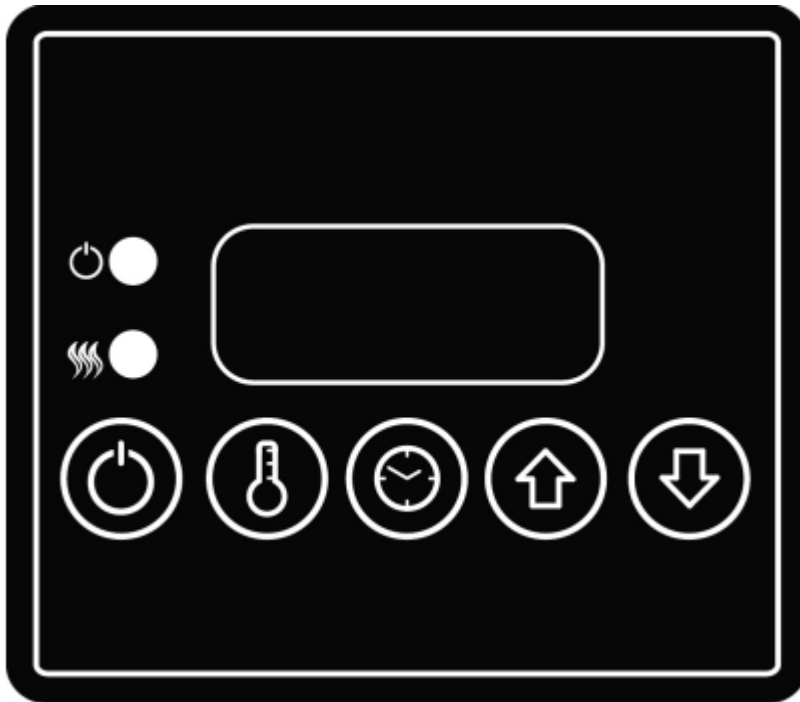

Operating Instructions









CONTROL PANEL

To set temperature:

- Press ON/OFF button. 
- Press SET TEMP button once  LED display will blink.
- Use +/- buttons   to set temperature. Maximum temperature setting is 275°F (135°C).
- Press SET TEMP button  again to lock in temperature. Note: Heating will not begin until timer is set.

To set timer:

- Press SET TIME button once  LED display for hours will blink.
- Use +/- buttons   to set hours.
- Press SET TIME button  again to lock in hours. The minutes LED will start blinking.
- Use +/- buttons   to set minutes.
- Press SET TIME  to lock in minutes and start cook cycle. Heat will turn off when time has expired.

NOTE: When outside temperature is cooler than 65°F (18°C) and/or altitude is above 3,500 feet (1067m), additional cooking time may be required. To ensure that meat is completely cooked use a meat thermometer to test internal temperature.

To RESET control panel: If control panel shows an error message, turn electric smoker off, unplug smoker from outlet, wait ten seconds, plug smoker back into outlet, then turn electric smoker on. This will reset control panel.

PRE-SEASONING

PRE-SEASON SMOKER PRIOR TO FIRST USE. Some smoke may appear during this time, this is normal.

1. Make sure water bowl is in place WITHOUT WATER.
2. Set temperature to 275°F (135°C) and run smoker for 3 hours.
3. During last 45 minutes, add ½ cup of wood chips to complete pre-seasoning.
4. Shut down and allow to cool.

LOADING FOOD INTO SMOKER

- Pre-heat smoker for 30 to 45 minutes at desired cooking temperature before loading food.
- DO NOT cover racks with aluminum foil as this will not allow heat to circulate properly.
- Do not overload smoker with food. Extra large amounts of food may trap heat, extend cooking time and cause uneven cooking. Leave space between food on racks and smoker sides to ensure proper heat circulation. If utilizing cooking pans, place pans on center of rack to ensure even cooking.
- Do not open smoker door unless necessary. Opening smoker door causes heat to escape, may extend cooking time, and may cause wood chips to flare up. Closing the door will re-stabilize the temperature and stop flare up.
- There will be a lot of smoke produced when using wood chips. Smoke will escape through seams and turn the inside of smoker black. This is normal. To minimize smoke loss around door, the door latch can be adjusted to further tighten the door seal against the body.
- To adjust door latch, loosen hex nut on door latch. Turn hook clockwise to tighten as shown. Secure hex nut firmly against door latch (see diagram).
- Check grease tray often during cooking. Empty grease tray before it gets full. Grease tray may need to be emptied periodically during cooking.

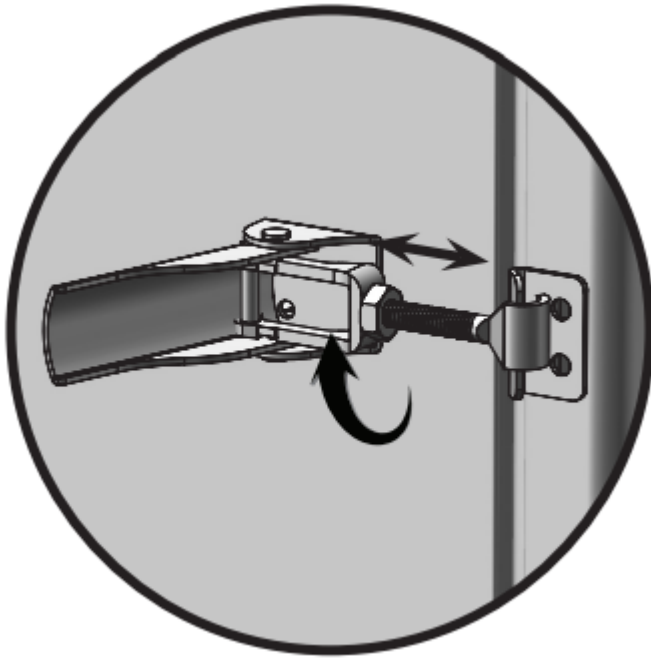

ADDING WOOD CHIPS

- Wood chips must be used in order to produce smoke and create the smoke flavor.
- Before starting smoker, place $\frac{1}{2}$ cup of wood chips in wood chip tray. Never use more than $\frac{1}{2}$ cup of wood chips at a time. Never use wood chunks or wood pellets.
- If wood chips do not smoke on low setting, increase temperature to 275°. After 8 to 10 minutes, or when wood chips begin to smolder, reduce temperature to desired low setting.
- You may use dry or pre-soaked wood chips in your smoker. Dry chips will burn faster and produce more intense smoke. Chips pre-soaked in water (for approximately 30 minutes) will burn slower and produce a less intense smoke.
- Check wood chip tray periodically to see if wood has burned down. Add more chips as needed.

To add wood chips:

1. Open smoker door and insert wood chip tray handle into holes in wood chip tray. See illustrations below.
2. Slide wood chip tray out of smoker and add wood chips.
3. Slide wood chip tray into smoker and remove handle from tray.
4. Close smoker door. Do not close smoker door with handle attached to tray

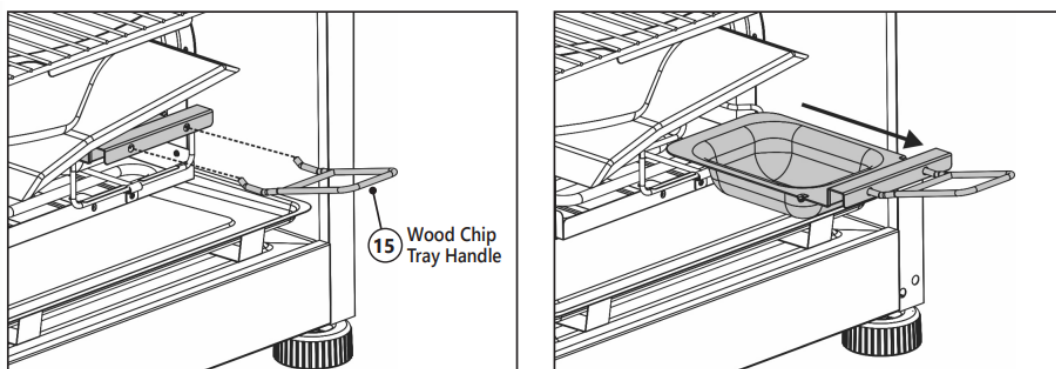

- Additional chips should not be added until any previously added chips have ceased generating smoke.
- Temperature may spike briefly after wood chips are added. It will stabilize after a short time. Do not adjust temperature setting.
- Do not leave old ashes in the wood chip tray. Once ashes are cold, empty tray. Tray should be cleaned out prior to and after each use to prevent ash buildup

CAUTION: A flare up may occur when door is opened. If wood chips flare up, immediately close door and vent, wait for wood chips to burn down, then open door again. Do not spray with water.

WARNING: Wood chip tray is HOT when smoker is in use and may cause burns. Use gloves when adding wood chips or emptying ashes.

WATER BOWL

- Wait until smoker reaches desired temperature.
- Fill water bowl to fill line with water or liquids like apple or pineapple juice.
- You may also add slices of fruit, onions or fresh dried herbs into the water to blend different subtle flavors into your smoked food.

Tip: For chicken or other foods high in moisture, little or no liquid is needed.

CLEANING AND STORAGE

ALWAYS MAKE SURE SMOKER IS COOL TO THE TOUCH BEFORE CLEANING AND STORING

- Be sure to clean smoker after each use. This will extend the life of your smoker and prevent mold and mildew.
- Clean rack supports, racks, water bowl and drip pan with a mild dish detergent. Rinse and dry thoroughly.
- Clean wood chip tray frequently to remove ash build up, residue and dust
- Dispose of cold ashes by placing them in aluminum foil, soaking with water and discarding in a non-combustible container.

- Clean the interior and exterior of smoker by simply wiping down with a damp cloth. Do not use a cleaning agent. Make sure to dry thoroughly.
- After cleaning, store smoker in a covered and dry area.
- When not in frequent use and using a cover, remember to check your smoker periodically to avoid possible rust and corrosion due to moisture buildup.

Troubleshooting



SYMPTOM	CAUSE	POSSIBLE SOLUTION
No power to controller (Does not beep when plugged into outlet).	Not plugged into outlet.	Plug into power source.
	House breaker tripped.	Reset breaker.
	Bad connection at controller.	Unplug connection and reconnect. Reference controller assembly steps in this manual.
	Bad connection at PCB (Power Control Board).	Unplug connection and reconnect. Reference PCB and replacement instructions.
	Faulty PCB (Power Control Board).	Call Smoke Hollow® for replacement at 1-866-4...
	Faulty controller.	Call Smoke Hollow® for replacement at 1-866-4...
	Faulty body wiring.	Call Smoke Hollow® for replacement at 1-866-4...
Power light not on (controller beeps when plugged in).	Smoker is not powered on.	Press on/off button.
	Faulty Controller.	Call Smoke Hollow® for replacement at 1-866-4...
No display on controller (power light is on).	Controller temperature is below -10°F (-23°C).	Remove controller from smoker and bring to temperature above 0°F (-18°C). Reference controller assembly steps in this manual.
	Faulty Controller.	Call Smoke Hollow® for replacement at 1-866-4...
Heating light is not on.	Temperature and time are not set.	Set temperature and time and wait 60 seconds for heating light to turn on.
	Faulty controller.	Call Smoke Hollow® for replacement at 1-866-4...
	Faulty body wiring.	Call Smoke Hollow® for replacement at 1-866-4...
Element is not on.	Bad connection at element.	Unplug connection and reconnect. Reference element access and replacement instructions.
	Faulty HTL (High Temp Limit Safety Shut-Off).	Call Smoke Hollow® for replacement at 1-866-4...



	Faulty element.	Call Smoke Hollow® for replacement at 1-866-475-5180. Reference element access instructions.
Cabinet temperature is not accurate.	Faulty controller.	Call Smoke Hollow® for replacement at 1-866-475-5180.
Smoker takes excessive amount of time to heat.	Climate.	Temperatures below 65°F (18°C) may extend heating time.
	Smoker plugged into an extension cord.	Plug smoker directly into power source. Maximum length of extension cord is 25ft (8m). Minimum gauge is 16.
	Door not closed properly.	Close door and adjust latch so that door seals completely around smoker.
	Water bowl not properly located.	Locate water bowl properly on supports. See assembly instructions for steps for proper installation.
	Faulty controller.	Call Smoke Hollow® for replacement at 1-866-475-5180.
Gap between the door and the smoker.	Improper door alignment.	Adjust door hinges.
	Damaged door seal.	Call Smoke Hollow® at 1-866-475-5180 for replacement door kit.
Grease leaking from smoker.	Door not closed properly.	Close door and adjust latch so door seals completely around smoker.
	Smoker is not level.	Move smoker to a level surface.
	Drip pan is not in proper location.	Align drip pan so that drain hole in pan and smoker align.
	Grease tray is full.	Empty grease tray and reinstall behind smoker.
	Drain tube is clogged.	Clean drain tube.
No smoke.	No wood chips.	Add wood chips. See Operating Instructions/Additional Accessories for Wood Chips.
Controller will not adjust temperature.	Faulty controller.	Call Smoke Hollow® for replacement at 1-866-475-5180.



Controller will not adjust time.	Faulty controller.	Call Smoke Hollow® for replacement at 1-866-4
Controller displays error code.		Call Smoke Hollow® at 1-866-475-5180 to report error code.

Access/Replacement: Power Control Board (PCB)

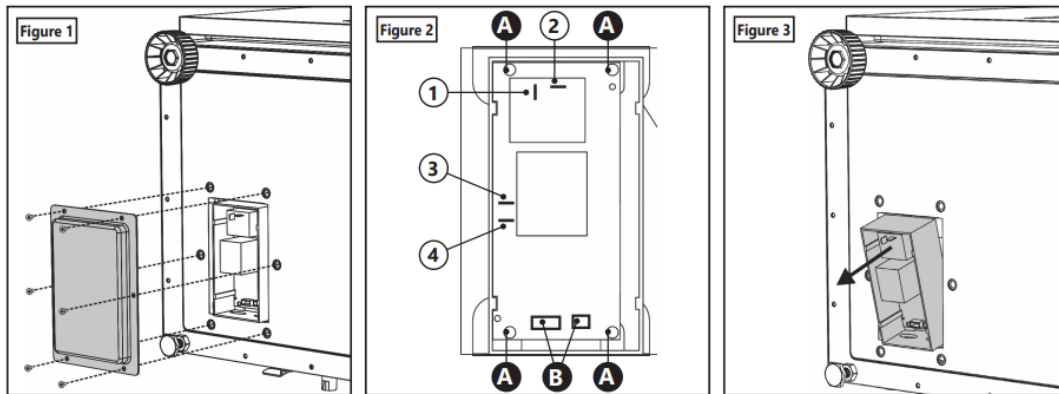

Tool needed for access and replacement: Phillips Head Screwdriver.

DIRECTIONS:

- Turn the smoker off.
- Unplug the smoker from power source.
- Locate the access panel for the power circuit board on the bottom of the smoker. See Figure 1.
- Remove the six screws and remove the access panel cover. See Figure 1.
- Carefully remove the wires from their terminals. See 1, 2, 3 and 4 on Figure 2 for locations. This may be easier with the use of pliers.
- Disconnect the two wire plugs from the power circuit board. See B on Figure 2 for locations. Grip the plug and pull straight up to disconnect.
- Remove the four screws from the outermost corners of the power circuit board. See A on Figure 2 for locations.
- Remove power circuit board and housing from the pocket and slip the wires one at a time out of the plastic housing. Tilting one end of the power circuit board will help remove it from the pocket (Caution: sharp edges). See Figure 3.
- Replacing the new power circuit board will be in the reverse order of removing the previous power circuit board. Use caution to replace wires in their original locations according to Figure 2.
- Reconnect the two wire plugs to the power circuit board. See B on Figure 2.

- Replace the power circuit board and housing into the pocket. See Figure 3.
- Replace the four screws of the power circuit board. See A on Figure 2.
- Replace the access panel cover and secure with the six screws. See Figure 1.

Access: Element

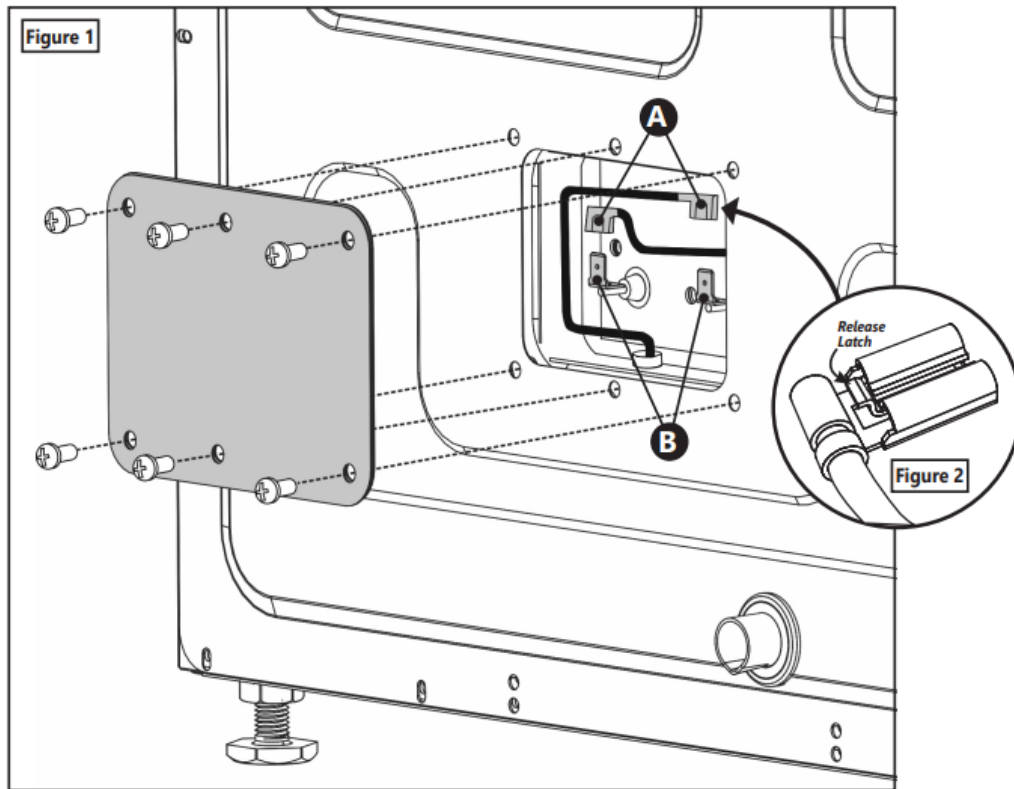

Tool needed for access: Phillips head screwdriver.

DIRECTIONS:

- Turn the smoker off.
- Unplug the smoker from power source and allow to cool completely.
- Locate the access panel for the element on the back of the smoker. See Figure 1.
- Remove the six (6) screws and remove the access panel cover (Caution: sharp edges). See Figure 1.
- Carefully remove heat shrink from the female leads (A), disconnect from male spades (B) and then reconnect.
- NOTE: Some female lead terminals will require you to press a small release latch to disconnect from male spades. See Figure 2.
- Re-install access panel to back of smoker.

Warning

This content is compiled from multiple sources and is provided for reference purposes only. It may not be complete or fully applicable to all situations. If you are unable to resolve your issue, please contact the product manufacturer or an authorized service provider for official support.

Document generated by [ManualsFile](#)