

USING THE OVEN

Oven Controls

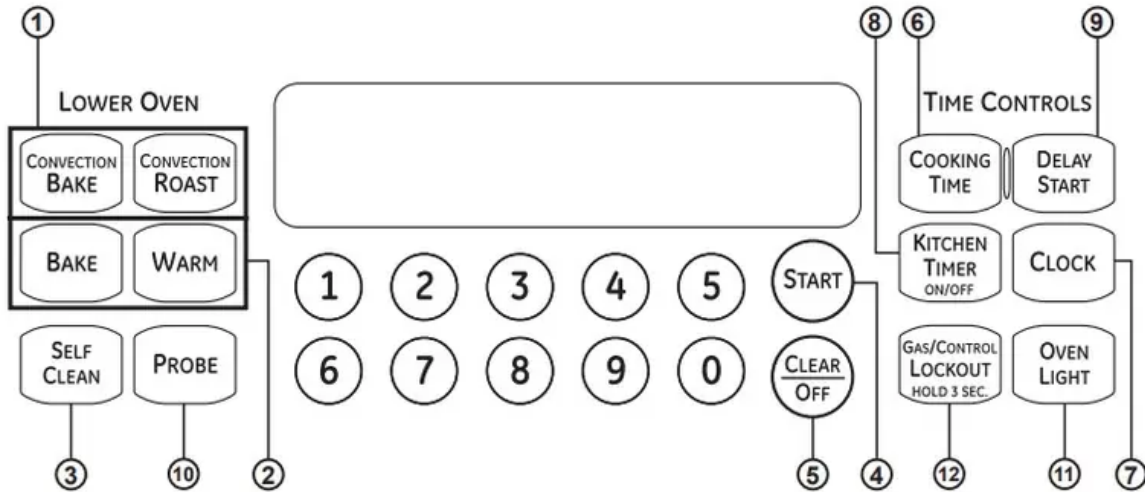

- 1. Convection Cooking Modes:** Convection cooking modes use increased air circulation to improve performance. The type of benefit depends on the mode. Your oven has the following convection cooking modes: Bake and Roast. See the Cooking Modes section for more information.
- 2. Traditional Cooking Modes:** Your oven has the following traditional cooking modes: Bake and Warm. See the Cooking Modes section for more information.
- 3. Clean:** Your oven has a Self Clean mode. See the Cleaning the Oven section for important information about using this mode.
- 4. Start:** Must be pressed to start any cooking, cleaning, or timed function.
- 5. Clear/Off:** Cancels ALL oven operations except the clock and timer.
- 6. Cooking Time:** Counts down cooking time and turns off the oven when the cooking time is complete. Press the Cooking Time pad, use the number pads to program a cooking time in hours and minutes, then press Start. This can only be used with Traditional Bake, Convection Bake and Convection Roast.
- 7. Clock:** Sets the oven clock time. Press Clock pad. Use the number pads to program the clock. Press Start to save the time.
- 8. Kitchen Timer:** Works as a countdown timer. Press the Kitchen Timer pad and the number pads to program the time in hours and minutes. Press the Start pad. The oven will continue to operate when the timer countdown is complete. To turn the timer off press the Kitchen Timer pad.

9. **Delay Start:** Delays when the oven will turn on. Use this to set a time when you want the oven to start. Press the Delay Time pad and use the number pads to program the time of day for the oven to turn on then press Start. Press the desired cooking mode and temperature then press Start. A cook time may also be programmed if desired. This can only be used with Traditional Bake, Convection Bake, Convection Roast and Self-Clean. **NOTE:** When using the delay time feature, foods that spoil easily—such as milk, eggs, fish, stuffings, poultry and pork—should not be allowed to sit for more than 1 hour before or after cooking. Room temperature promotes the growth of harmful bacteria. Be sure that the oven light is off because heat from the bulb will speed harmful bacteria growth.
10. **Probe:** Monitors internal food temperature and turns the oven off when the food reaches the programmed temperature. Insert the probe, program the cooking mode, and program the probe temperature. See the Cooking Modes section for more information. The probe can only be used with Traditional Bake and Convection Roast.
11. **Oven Light:** Turns the oven light on or off.
12. **Gas/Control Lockout:** Touch and hold the Gas/Control Lockout pad for 3 seconds to lock/ unlock the surface burners, oven burners and control panel so they cannot be activated.

Oven Air Vents

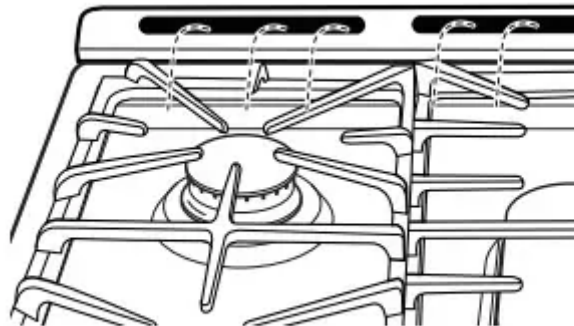

Never block the vents (air openings) of the range. They provide the air inlet and outlet that are necessary for the range to keep cool and operate properly with correct combustion.

Air openings are located at the rear of the cooktop, at the top and bottom of the oven door, and at the bottom of the range.

Special Features

There are several different special features on your oven. To change the settings of these special features, press the Bake and Warm pads at the same time and hold for three seconds. (SF) will appear in the display. Select the feature you want to change. When the

change has been made, press the Start key to save the change and return to the time of day.

Adjust the Oven Temperature

This feature allows the oven baking temperature to be adjusted up to 35°F hotter or down to 35°F cooler. Use this feature if you believe your oven temperature is too hot or too cold and wish to change it.

Press the Bake pad to enter the temperature adjustment mode. A number between 35 and -35 will display.

Use the number pads to set the desired temperature adjustment and use the Bake pad to change between negative and positive.

Press the Start pad to save the temperature adjustment.

End of Timer Signals

This is the tone that signals the end of a timer. The tone can be continuous (Con bEEp) or one repeating beep (bEEp). A continuous setting will continue to sound a tone until a button on the control is pressed. Press the Kitchen Timer pad to view the current setting and then to change the setting.

Fahrenheit or Celsius Temperature Display

The oven control is set to use Fahrenheit temperatures (F), but you can change it to use Celsius temperatures (C). Press the Warm and Cook Time pads at the same time to view the current setting, press again to change the setting.

Clock Display

This feature specifies how the time of day will be displayed or if no time of day will be displayed. You can select a standard 12-hour clock (12 hr), 24-hour military time display (24 hr), or no clock displayed (OFF). Press the Clock pad to view the current setting, press again to change the setting.

Autorecipe Conversion

This feature (ON/OFF), automatically reduces the programmed recipe temperature in Convection Bake mode by 25°F. The default setting for this feature is off.

Note: This option does not convert baking time, only temperatures. This option does not adjust temperatures for Convection Roast mode. Press Bake to view the current setting. Press again to change the setting.

Using the Sabbath Feature



(Designed for use on the Jewish Sabbath and Holidays)

The Sabbath feature can be used for baking in the lower oven. It cannot be used for convection, warm, self-cleaning or Delay Start cooking.

NOTE: The oven light comes on automatically when the door is opened and goes off when the door is closed. The bulb may be removed. See the Oven Light Replacement section. On models with a light switch on the control panel, the oven light may be turned on and left on.

How to Set for Regular Baking:

Make sure the clock shows the correct time of day and the oven is off.

1. Press and hold both the Bake and Warm pads, at the same time, until the display shows (SF).
2. Tap the Delay Start pad until (SAb bAtH) appears in the display.
3. Touch the Start pad and (▷) will appear in the display.
4. Touch the Bake pad. No signal will be given.

Using the number pads, enter the desired temperature between 170° and 550°. No signal or temperature will be given.

Touch the Start pad.

After a random delay period of approximately 30 seconds to 1 minute, (▷▷) will appear in the display, indicating that the oven is baking. If (▷▷) doesn't appear in the display, start again at Step 4.

To adjust the oven temperature, touch the Bake pad, enter the new temperature using the number pads and touch the Start pad.

NOTE: The Clear/Off and Cooking Time pads are active during the Sabbath feature.

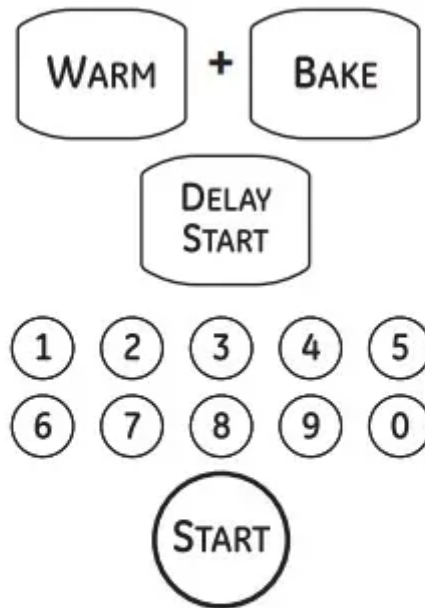

When the display shows (⇒) the oven is set in Sabbath. When the display shows (⇒C) the oven is baking/roasting.

How to Set for Timed Baking-Immediate Start and Automatic Stop:

Make sure the clock shows the correct time of day and the oven is off.

1. Press and hold both the Bake and Warm pads, at the same time, until the display shows (SF).
2. Tap the Delay Start pad until (SAb bAtH) appears in the display.
3. Touch the Start pad and (⇒) will appear in the display.
4. Touch the Cooking Time pad.
5. Touch the number pads to set the desired length of cooking time between 1 minute and 9 hours and 99 minutes. The cooking time that you entered will be displayed.
6. Touch the Start pad.
7. Touch the Bake pad. No signal will be given.
8. Using the number pads, enter the desired temperature. No signal or temperature will be given.
9. Touch the Start pad.
10. After a random delay period of approximately 30 seconds to 1 minute, (33) will appear in the display, indicating that the oven is baking/roasting. If (⇒C) doesn't appear in the display, start again at Step 7.

To adjust the oven temperature, touch the Bake pad, enter the new temperature using the number pads and touch the Start pad.

When cooking is finished, the display will change from (▷C) to (▷) and (0:00) will appear, indicating that the oven has turned OFF but is still set in Sabbath. Remove the cooked food.

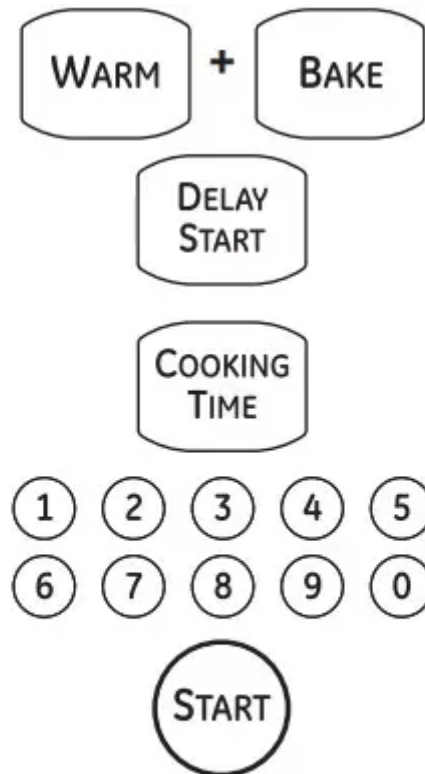

When the display shows (▷) the oven is set in Sabbath. When the display shows (▷C) the oven is baking/roasting.

How to Exit the Sabbath Feature:

1. Touch the Clear/Off pad.
2. If the oven is cooking, wait for a random delay period of approximately 30 seconds to 1 minute, until only (▷) is in the display.
3. Press and hold both the Bake and Warm pads, at the same time, until the display shows (SF).
4. Tap the Delay Start pad until (12 shdn) or (no shdn) appears in the display. (12 shdn) indicates that the oven will automatically turn off after 12 hours, (no shdn) indicates that the oven will not automatically turn off.
5. Touch the Start pad.

NOTE: If a power outage occurred while the oven was in Sabbath, the oven will automatically turn off and stay off even when the power returns. The oven control must be reset.

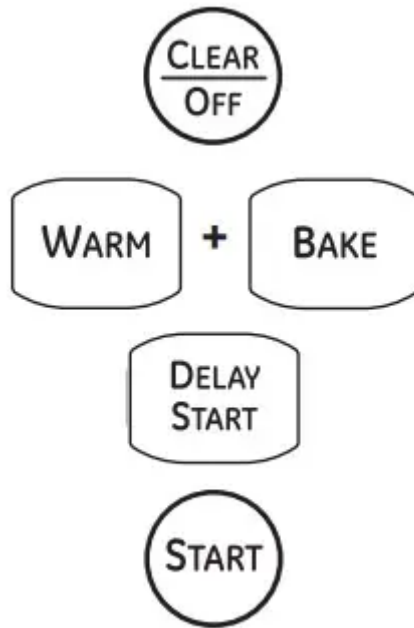

Oven Racks



Upper Oven

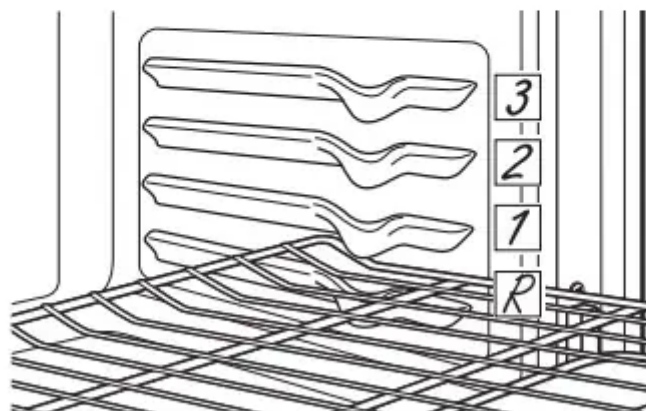

Lower Oven

Your oven has two rack positions in the upper oven (A, B) and four rack positions in the lower oven (R, 1,2,3) Recommended rack positions for various types of foods are provided in the Cooking Guide. Adjusting rack position is one way to impact cooking results. For



example, if you would prefer darker tops on cakes, muffins, or cookies, try moving food one rack position higher. If you find foods are too brown on top try moving them down next time.

When baking with multiple pans and on multiple racks, ensure there is sufficient space between pans to allow air to flow.

Flat Racks

When placing and removing cookware, pull the rack out to the bump (stop position) on the rack support.

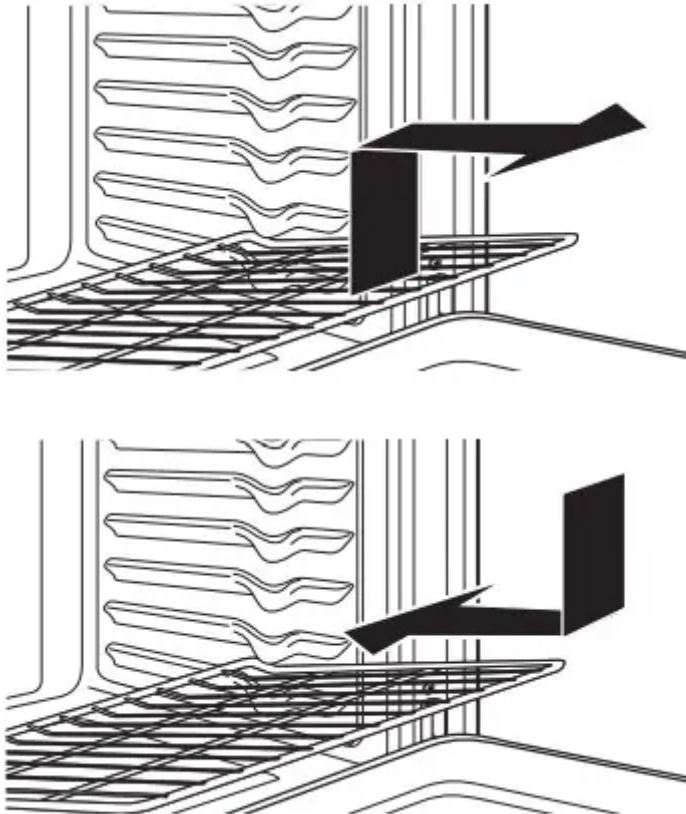

To remove a rack, pull it toward you, tilt the front end up and pull it out.

To replace, place the curved end of the rack (stop-locks) onto the oven supports, tilt up the front of the rack and push the rack in.

Racks may become difficult to slide, especially after a self-clean. Put some vegetable oil on a soft cloth or paper towel and rub onto the left and right edges.

Cookware

Cookware Guidelines

The material, finish, and size of cookware affect baking performance.

Dark, coated and dull pans absorb heat more readily than light, shiny pans. Pans that absorb heat more readily can result in a browner, crisper, and thicker crust. If using dark and

coated cookware check food earlier than minimum cook time. If undesirable results are obtained with this type of cookware consider reducing oven temperature by 25° F next time.

Shiny pans can produce more evenly cooked baked goods such as cakes and cookies.

Glass and ceramic pans heat slowly but retain heat well. These types of pans work well for dishes such as pies and custards.

Air insulated pans heat slowly and can reduce bottom browning.

Keep cookware clean to promote even heating.

Cooking Modes

Your new oven has a variety of cooking modes to help you get the best results. These modes are described below. Refer to the Cooking Guide section for recommendations for specific foods. Remember, your new oven may perform differently than the oven it is replacing.

Bake

The bake mode is for baking and roasting. This mode uses heat primarily from the lower burner but also from the upper burner to cook food. When preparing baked goods such as cakes, cookies, and pastries always preheat the oven first. Follow recipe recommendations for food placement. If no guidelines are provided center food in the oven. To use this mode press the Bake pad, enter a temperature, and then press Start.

Warm

Warm mode is designed to keep hot foods hot for up to 3 hours. To use this mode, press the Warm pad then press Start. Cover foods that need to remain moist and do not cover foods that should be crisp. Preheating is not required. Do not use warm to heat cold food other than crisping crackers, chips or dry cereal. It is also recommended that food not be kept warm for more than 2 hours.

Broiling Modes

Broil is only available in the upper oven. Always broil with the door closed. Monitor food closely while broiling. Use caution when broiling on upper rack positions as placing food closer to the broil burner increases smoking, spattering, and the possibility of fats igniting. Broiling on rack position 5 is not recommended.

Try broiling foods that you would normally grill. Adjust rack positions to adjust the intensity of the heat to the food. Place foods closer to the broil burner when a seared surface and rare interior is desired. Thicker foods and foods that need to be cooked through should be broiled on a rack position farther from the burner.

Convection Bake

The Convection Bake mode is intended for baking on a single rack. This mode may use heat from the upper and lower burners, along with air movement from the convection fan to enhance cooking evenness. Your oven is equipped with Auto Recipe Conversion, so it is not necessary to convert the temperature when using this mode. To use this mode press the Bake pad under Convection, enter a temperature, and then press Start. Always preheat when using this mode.

Convection Roast

The Convection Roast mode is intended for roasting whole cuts of meat on a single rack. This mode may use heat from the upper and lower bake burner along with air movement to improve browning and reduce cooking time. It is not necessary to convert temperature. Check food earlier than the recipe suggested time when using this mode, or use the probe (on some models). To use this mode press the Roast pad under Convection, enter a temperature, and then press Start. It is not necessary to preheat when using this mode.

Probe

Internal food temperature is frequently used as an indicator of doneness, especially for roasts and poultry. The Probe mode monitors the internal food temperature and turns the oven off when the internal food temperature reaches the programmed temperature.

The temperature probe can only be used with Traditional Bake, Convection Bake, and Convection Roast modes.

To use the probe with preheating:

1. Press the desired cook mode (Traditional Bake, Convection Bake, or Convection Roast) pad and enter the desired cooking temperature.
2. Insert the probe into the food (see Proper Probe Placement Guidelines in this section).
3. Once the oven is preheated, place the food in the oven and connect the probe to the probe outlet, making sure it is fully inserted. Use caution, the oven walls and probe outlet are hot.
4. Program the probe temperature by pressing the Probe pad and entering the desired food temperature. The maximum internal food temperature that you can set is 200° F.

Upper Oven

To Use the Upper Oven

1. Push in and turn the upper oven knob to any desired setting.
2. Allow the upper oven to preheat.
 - The upper oven signal light is located on the upper left side of the knob and glows when the knob is in the ON position. It remains ON until the knob is moved to the OFF position.

- The “Heating” signal light is located on the upper right side of the knob and glows when the heating elements are active. Preheat is complete after the “Heating” signal has turned off for the first time with each use. A tone will NOT sound when the oven is finished preheating.

NOTES:

- The lower oven cannot be used during a self-clean cycle of the upper oven.
- Do not put food, foil or cookware directly on the bottom of the upper oven.



Push in and turn the upper oven knob to any desired setting.

- If foods require a cover, use only foil or lids able to withstand baking temperatures. Do not use plastic.
- For best baking results, use rack position B. If your dish is too tall, place on rack position A.
- For best results, bake cakes in lower oven.

How to Set the Upper Oven for Broiling

1. Place the meat or fish on a broiler grid in a broiler pan.
2. Follow suggested rack positions in the Broiling Guide.
3. The oven door must be closed during broiling.
4. Push in and turn the upper oven knob to broil setting. Serve the food immediately, and leave the pan outside the oven to cool during the meal for easiest cleaning.

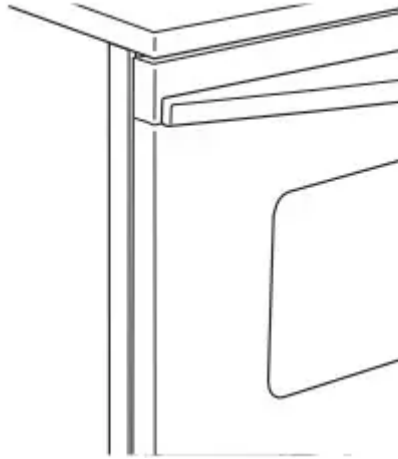

Close the door. Always broil with the door closed.

Aluminum Foil and Oven Liners

Foil may be used to catch spills by placing a sheet on a lower rack, several inches below the food. Do not use more foil than necessary and never entirely cover an oven rack with aluminum foil. Keep foil at least 1-1/2" from oven walls to prevent poor heat circulation.

Cooking Guide



FOOD TYPE	RECOMMENDED MODE(S)	OVEN (Upper/ Lower)	RECOMMENDED RACK POSITION(S)	ADDITIONAL SUGGESTIONS
Baked Goods				
Layer cakes, sheet cakes, bundt cakes, muffins, quick breads, biscuits, scones on a Single Rack	Bake	Lower Upper	2 B	Use shiny cookware.
Layer cakes* on Multiple Racks	Convection Multi-Bake Bake	Lower	1 and 3	Ensure adequate airflow (see illustration below).
Chiffon cakes (angel food)	Bake	Lower	1	Use shiny cookware.
Cookies, biscuits, scones on a Single Rack	Bake	Lower Upper	2B	Use shiny cookware.
Cookies, biscuits, scones on Multiple Racks	Convection Multi-Bake Bake	Lower	1 and 3	Ensure adequate airflow.
Beef & Pork				
Hamburgers	Broil Hi	Upper	B	Use a broil pan; move food

				down for more doneness/less searing. Watch food closely when broiling.
Steaks & Chops	Broil Hi	Upper	B	Use a broil pan; move food down for more doneness/less searing. Watch food closely when broiling.
Roasts	Convection Roast Bake	Lower	R or 1	Leave uncovered, use a low sided pan such as a broil pan.
Poultry				
Whole chicken	Convection Roast Bake	Lower	R or 1	Leave uncovered, use a low sided pan such as a broil pan.
Bone-in chicken breasts, legs, thighs	Broil Lo Bake	Lower Upper	A 2	Watch food closely when broiling.
Boneless chicken breasts	Broil Lo Bake	Lower Upper	A 2	Watch food closely when broiling
Whole turkey	Convection Roast Bake	Lower	R or 1	Leave uncovered, use a low sided pan such as a broil pan. Watch food closely when broiling.

Turkey Breast	Bake	Lower	2	Leave uncovered, use a low sided pan such as a broil pan
Fish	Broil Lo Bake	Lower Upper	A 2	Watch food closely when broiling.
Casseroles	Bake	Lower Upper	2 B	
Frozen Convenience Foods				
Pizza, french fries, tator tots, chicken nuggets, appetizers on a Single Rac	Bake	Lower Upper	2 B	Use shiny cookware.
Pizza, french fries, tator tots, chicken nuggets, appetizers on Multiple Racks	Convection Multi- Bake Bake	Lower	1 and 3	Use shiny cookware.

*When baking four cake layers at a time, stagger the pans as shown so that one pan is not directly above another.

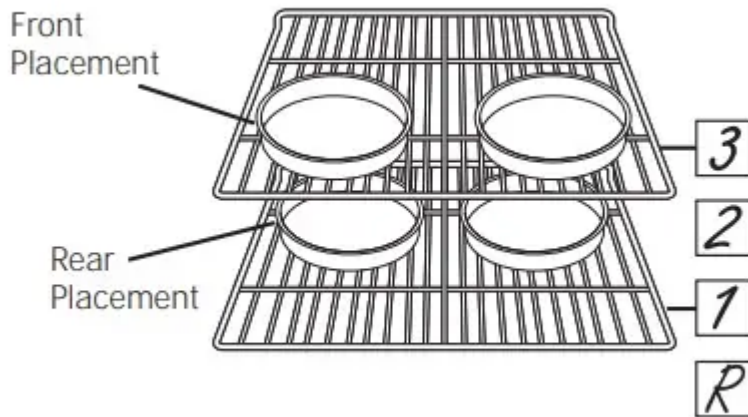

CARE AND CLEANING

Oven

Be sure electrical power is off and all surfaces are cool before cleaning any part of the range.

Control Panel and Knobs

Wipe the control panel after each use of the oven with a damp cloth. For cleaning, use mild soap and water or a 50/50 solution of vinegar and water. Rinse with clean water. Polish dry with a soft cloth. Do not use abrasive cleansers, strong liquid cleansers, plastic scouring pads or oven cleaners on the control panel—they will damage the finish. Do not try to bend knobs by pulling them up or down or by hanging a towel or other such loads. This can damage the gas valve shaft.

The control knobs may be removed for easier cleaning. With knobs in the OFF position pull them straight off the stems.

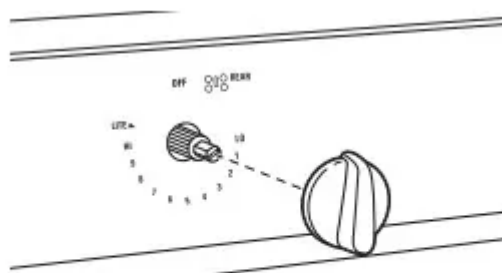

Surface burner knob

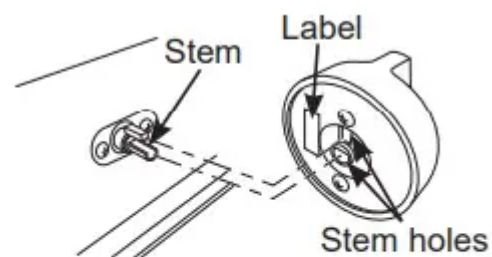

Knobs with two stem holes have special locations

The knobs can be washed by hand with soap and water or in a dishwasher. Not all knobs are interchangeable. To determine the correct location of a particular knob, examine the back of the knob. A knob with a label or two stem holes should be replaced on the front panel first by matching the shape of the knob holes to the shape of the control panel stems. The remainder of the knobs

having no labels and only one stem hole can then be replaced on the front panel anywhere there is a single stem.

Oven Exterior and Cooktop Surface

Do not use oven cleaners, abrasive cleansers, strong liquid cleansers, steel wool, plastic scouring pads, or cleaning powders on the interior or exterior of the oven. Clean with a mild soap and water or a 50/50 solution of vinegar and water. Rinse with clean water and dry with a soft cloth. When cleaning surfaces, make sure that they are at room temperature and not in direct sunlight.

If a stain on the door vent trim is persistent, use a mild abrasive cleaner and a sponge-scrubber for best results. Spillage of marinades, fruit juices, tomato sauces and basting liquids containing acids may cause discoloration and should be wiped up immediately. Let hot surfaces cool, then clean and rinse.

Stainless Steel Surfaces (on some models)

Do not use a steel wool pad; it will scratch the surface.

To clean the stainless steel surface, use warm sudsy water or a stainless steel cleaner or polish. Always wipe the surface in the direction of the grain. Follow the cleaner instructions for cleaning the stainless steel surface.

Cleaners with oxalic acid such as Bar Keepers Friend Soft Cleanser™ will remove surface rust, tarnish and small blemishes. Use only a liquid cleanser free of grit and rub in the direction of the brush lines with a damp, soft sponge.

To inquire about purchasing cleaning products including stainless steel appliance cleaner or polish, read the Assistance/Accessories sections at the beginning of this manual.

Oven Interior

The interior of your new oven can be cleaned manually or by using the Steam Clean or Self Clean modes.

Spillage of marinades, fruit juices, tomato sauces and basting liquids containing acids may cause discoloration and should be wiped up as soon as hot surfaces cool, then clean and rinse.

Manual Cleaning

Do not use oven cleaners, abrasive cleaners, strong liquid cleansers, steel wool, scouring pads, or cleaning powders on the interior of the oven. Clean with a mild soap and water or 50/50 solution of vinegar and water. Rinse with clean water and dry with a soft cloth. When cleaning surfaces, make sure that they are at room temperature and not in direct sunlight.

Oven Interior

Self Clean Mode

Read Self-Cleaning Oven Safety Instructions at the beginning of this manual before using Self Clean Mode. Self clean uses very high temperatures to clean the oven interior. The oven door will lock when using this feature. Before operating the self-clean cycle, pre-wash inner door and inside window before self-cleaning. Wipe inner black door before self clean. Remove all items from the oven other than enameled (dark color) racks. Shiny or silver racks, the meat probe, and any cookware or other items should all be removed from the oven before initiating a self-clean cycle. The surface burners must be turned off prior to the self-clean start time. Cooktop burners will not start during self clean cycle. Both ovens can not be self-cleaned at the same time. Close the door.

Cleaning Lower Oven

Press the Clean pad once and a default self-clean time is displayed. Press the Start pad or use the number pads to enter any clean time between 3 and 5 hours and press Start. For heavily soiled ovens 5 hours is recommended. The oven will turn off automatically when the self-clean cycle is complete. The door will stay locked until the oven has cooled down. After the oven has cooled down wipe any ash out of the oven.

Cleaning Upper Oven

The oven door must be closed and all controls set correctly for the cycle to work. Rotate upper oven knob to self-clean position. Touch the Start pad. Doors will lock automatically. The display will show the clean time remaining. If the upper door is not locked and remaining clean time is not displayed, within 1 minute of initiating the cycle rotate the knob to the Off position and open both doors for 10 minutes. Repeat step 1. It will not be possible to open the oven door until the temperature drops below the lock temperature and the LOCKED DOOR light goes off.

The oven shuts off automatically when the clean cycle is complete. When the LOCKED DOOR light is off, the door will unlock automatically. Rotate knob to the off position. The words LOCK DOOR will flash and the oven control will signal if you set the clean cycle and forget to close the oven door. To stop a clean cycle, touch the Clear/Off pad then turn the oven control knob to the OFF position. After some period of time, the LOCKED DOOR light will go off. This will indicate that the oven has cooled below the locking temperature and gas is able to flow to the cooktop. The doors will unlock automatically. After you complete the first oven clean cycle, you can start the second oven clean cycle.

IMPORTANT: The health of some birds is extremely sensitive to the fumes given off during the self-cleaning cycle of any range. Move birds to another well-ventilated room.

Oven Racks

All oven racks may be cleaned by hand with an abrasive cleaner or steel wool. Black porcelain-coated oven racks may remain in the oven during the self-cleaning cycle without being damaged. If nickel-plated oven racks remain in the oven during the self-cleaning cycle, they will lose their luster and become hard to slide. It will be necessary to grease all oven

rack side edges with a light coating of vegetable oil after cleaning them by hand or in the oven. This will help maintain the ease of sliding the racks in and out of the oven.

Probe

The temperature probe may be cleaned with soap and water or a soap-filled scouring pad. Cool the temperature probe before cleaning. Scour stubborn spots with a soap-filled scouring pad, rinse and dry.

To order additional temperature probes read the Assistance and Accessories sections at the beginning of this manual.

- Do not immerse the temperature probe in water.
- Do not store the temperature probe in the oven.
- Do not leave the temperature probe inside the oven during a self or steam clean cycle.

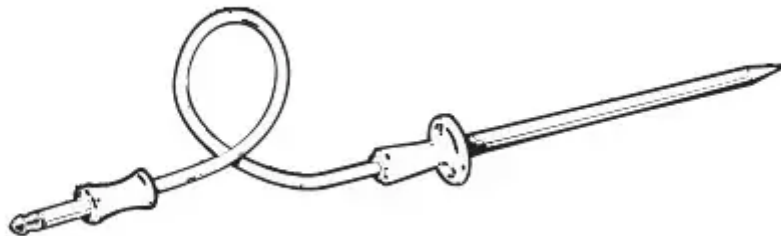

Cooktop

Removal of Surface Burners for Cleaning

Turn all controls OFF. Allow cooktop to cool before removing grates and burner parts. When removing the burner caps and heads, remember their size and location. Replace them in the same location after cleaning.

CAUTION: Do not attempt to remove bridge burner, oval burner or tri-ring burner caps from burner heads.

**Round Burner Cap
(Removable)**

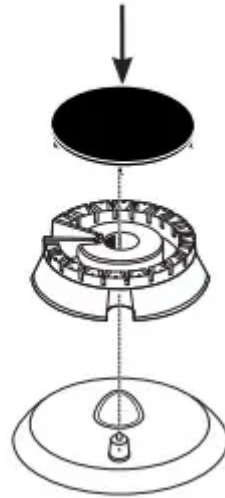

Round Burner

The burner caps and burner heads can be lifted off the cooktop.

**Oval Burner Head
and Cap Assembly
(Non-Removable)**



**Electrode
(Non-Removable)**

Oval Burner (on some models)

Cap is permanently attached to the burner head.

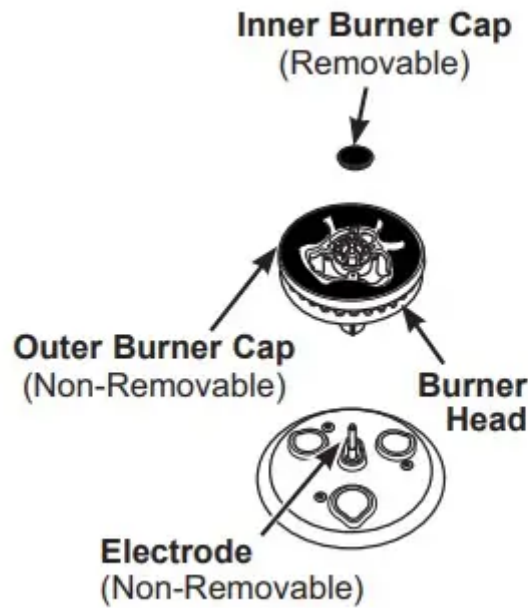

Tri-Ring Burner (on some models)

The small tri-ring burner cap can be lifted off for cleaning. The outer cap is permanently attached to the burner head assembly. Lift the burner head assembly off the cooktop as one piece.

Cleaning The Burners

Burner Caps

Wash burner caps in hot, soapy water and rinse with clean water. You may scour with a plastic scouring pad to remove burned-on food particles. The round caps may also be cleaned in your dishwasher.

Burner Heads

Wash the burner heads routinely, especially after bad spillovers, which could clog the openings. Lift burners off when cool. Use hot, soapy water. Rinse with clean water. For more stubborn stains, use a brush with plastic bristles.

NOTE: Do not use steel wool or scouring powders to clean the burner parts as these may clog the parts.

Never wash burner heads in your dishwasher as dishwasher detergents will discolor your burners.

The ports in the burner heads must be kept clean at all times for an even, unhampered flame.

Clogged or dirty burner ports or electrodes will not allow the burner to operate properly.

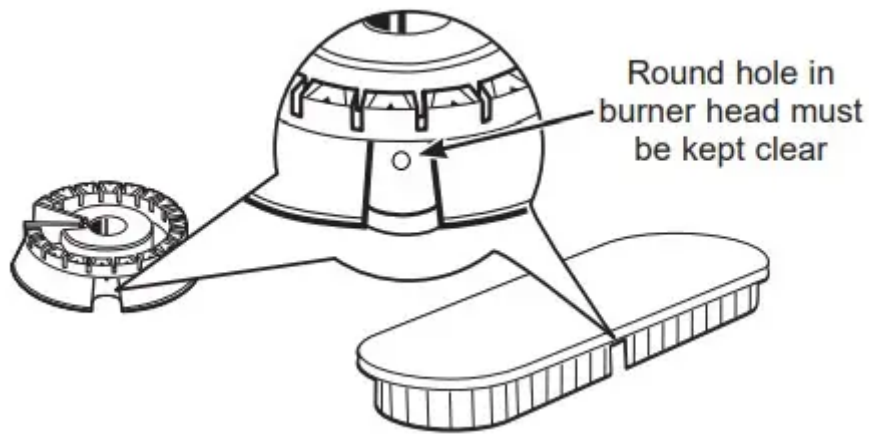

For proper ignition, make sure the small hole in the notch that fits over the electrode is kept open. A sewing needle or wire twist-tie works well to unclog it.

After cleaning

Before putting the burner caps, heads (on some models) and oval head/cap assembly back, shake out excess water and allow them to dry thoroughly.

Replacing Burner Heads

Replace burner heads in the correct locations according to size.

Burner Caps

Replace burner caps on burner heads. Make sure each cap fits securely and sits flat on its corresponding burner head.



Burner cap is NOT properly seated.



Burner cap is NOT properly seated.

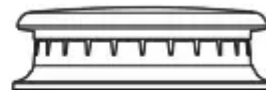

Burner cap is properly seated.

CAUTION: Any spill on or around an electrode must be carefully cleaned. Take care to not hit an electrode with anything hard or it could be damaged.

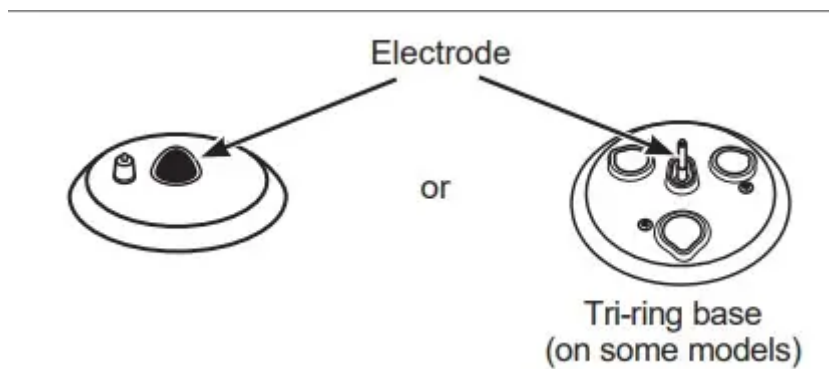

The electrode of the spark igniter is exposed when the burner head is removed. When one burner is turned to LITE, all the burners spark.

Do not attempt to disassemble or clean around any burner while another burner is on. An electric shock may result, which could cause you to knock over hot cookware.

Burner Grates

Grates should be washed in hot, soapy water and rinsed with clean water or in the dishwasher. To soften burned-on food, place grates in a plastic bag containing $\frac{1}{2}$ -cup of household ammonia for several hours. Afterward, scrub grates with a plastic scouring pad soaked in hot, soapy water. Rinse well and dry.

When replacing the grates, be sure to locate them correctly on the cooktop. Grates are identified by the words LEFT and RIGHT on their bottom surfaces. Grate should fit securely into the cooktop.

Grates will gradually lose their shine due to their continual exposure to high temperatures.

Cleaning the Grates in the Self-Clean Oven

If your cooktop grates do not have rubber bumpers on their bottom surface and your oven racks are coated with black porcelain, your grates may be cleaned in the oven using the self-clean cycle. If your grates have rubber bumpers, do not attempt to clean your grates in the oven. Doing so will destroy the rubber bumpers and may affect the function of your surface burners.

Place oven racks in the positions labeled "R", "2" and "4" in the illustration. Place a single grate on each rack. Follow instructions for the self-clean mode in the Cleaning the Oven section of this manual.

NOTE: Use caution when removing the grates from the oven after the self-clean cycle has ended. The grates may still be hot.

After cleaning, you may notice a white residue on the grates. Wipe it off with a damp sponge. If white spots persist, wet the sponge with a 50/50 solution of vinegar and water.

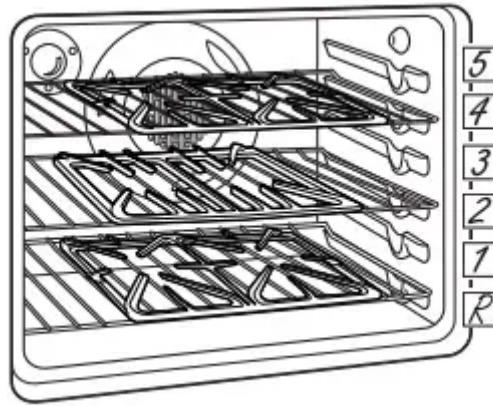

The oven has 6 rack positions. Place the gray porcelain-coated racks in positions “R”, “2” and “4” for self-cleaning the grates.

Grate Support Bumpers

If any of the rubber grate support bumpers in the cooktop are missing or damaged, replacement parts can be obtained by calling 1.800.GE.CARES.

To insert the new bumpers, simply place the cone-shaped end of the bumper into the hole in the cooktop and push down while gently twisting the bumper.

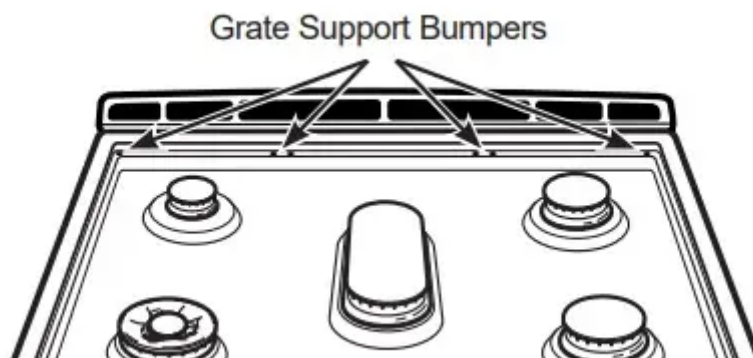

Griddles

Griddle Precautions:

If something has spilled under the griddle, it should be cleaned up as soon as possible to prevent the spill from getting baked onto the cooktop.

Do not allow grease to accumulate under the griddle as it can be a fire hazard. Clean under the griddle with hot soapy water as soon as it is cool.

Do not wash your griddle in the dishwasher.

Do not place your griddle in a microwave oven.

Door

To clean the inside of the door

Do not allow excess water to run into any holes or slots in the door.

Wipe dishwashing detergent over any baked-on spatters on the glass. Use a single sided safety razor blade to clean it off. Then wipe over the glass with a soapy cloth to remove any residue and dry off.

The area outside the gasket can be cleaned with a soap-filled plastic scouring pad.

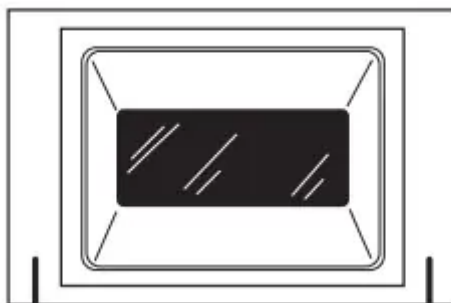

The gasket is designed with a gap at the bottom to allow for proper air circulation.

Do not rub or clean the door gasket—it has an extremely low resistance to abrasion.

If you notice the gasket becoming worn, frayed or damaged in any way or if it has become displaced on the door, you should have it replaced.

Oven Light

NOTE: The glass cover should be removed only when cold. Wearing latex gloves may offer a better grip.

Before replacing the bulb, disconnect electrical power to the oven at the main fuse or circuit breaker panel. Let the bulb cool completely before removing it. For your safety do not touch a hot bulb with a damp cloth. If you do the bulb may break.

To remove:

Turn the glass cover counterclockwise 1/4 turn until the tabs of the glass cover clear the grooves of the socket. Remove the bulb.

To replace:

Put in a new 40-watt appliance bulb. Place the tabs of the glass cover into the grooves of the socket. Turn the glass cover clockwise 1/4 turn.

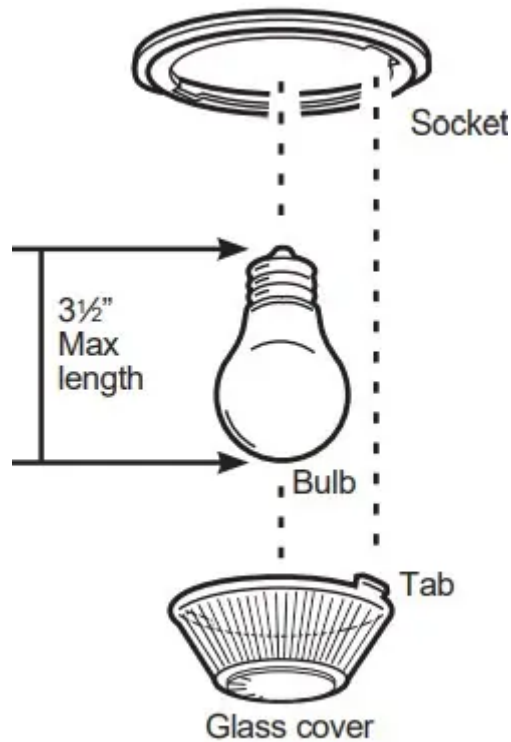

NOTE:

- A 40-watt appliance bulb is smaller than a standard 40-watt household bulb.
- Reconnect electrical power to the oven once the new bulb is installed.
- For improved lighting inside the oven, clean the glass cover frequently using a wet cloth. This should be done when the oven is completely cool.

Lower Oven Door

The door is very heavy. Be careful when removing and lifting the door. Do not lift door by the handle.

To Remove the Door:

1. Fully open the door.
2. Pull the hinge locks up and away from the range frame to the unlocked position.
3. Firmly grasp both sides of the door near the top.
4. Close door until the top of the door is approximately 6" from the range frame.
5. Lift door up and away from the range until both hinge arms are clear of the slots in the range frame.



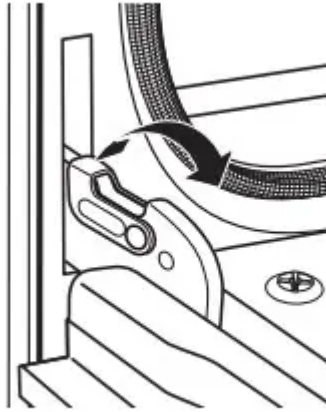

Pull hinge locks up to unlock



Removal position

To Replace the Door:

1. Firmly grasp both sides of the door near the top.
2. With the door at the same angle as the removal position, rest the notch on the underside of the left hinge arm on the bottom edge of the left hinge slot.

The notch in the hinge arm must be fully seated into the bottom of the slot. Repeat for the right side.

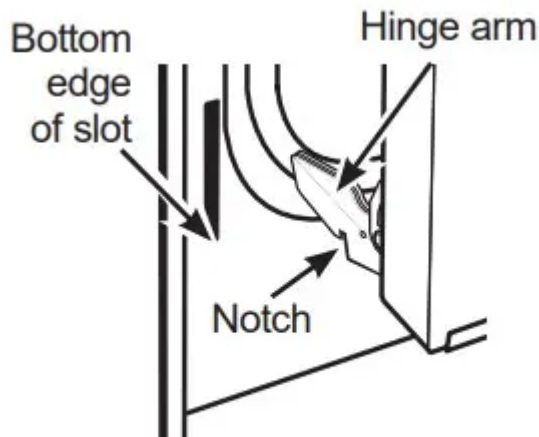

Rest notch on bottom edge of hinge slot

3. Fully open the door. If the door will not fully open, the notches in the bottoms of the hinge arms have not seated correctly in the bottom edge of the slot. Lift the door off the range and repeat previous step.

4. Push the hinge locks toward the range cavity and down to the locked position.

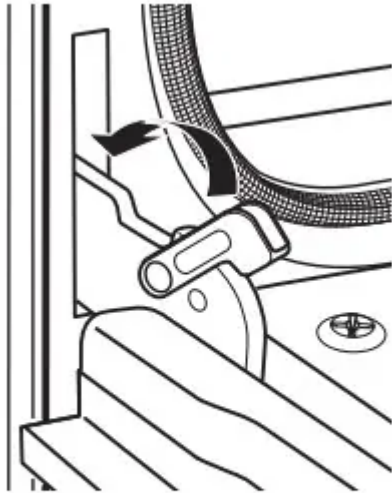

Push hinge locks
down to lock

5. Close the oven door.

Upper Oven Door

The door is very heavy. Be careful when removing and lifting the door. Do not lift door by the handle.

To Remove the Door:

1. Fully open the door.
2. Lift up on the hinge lock toward the oven frame until they stop.
3. Close the door to 45 degrees (you will feel the door stop). The hinge lock will contact the oven frame.
4. On both sides of the door, press down on the release buttons on each hinge.
5. Lift door up until it is clear of the hinge.
6. Pull on hinge arms slightly to relieve pressure on the locking tabs.
7. Push the hinge locks down onto the hinge.
8. Push the hinges in toward the unit so they are closed

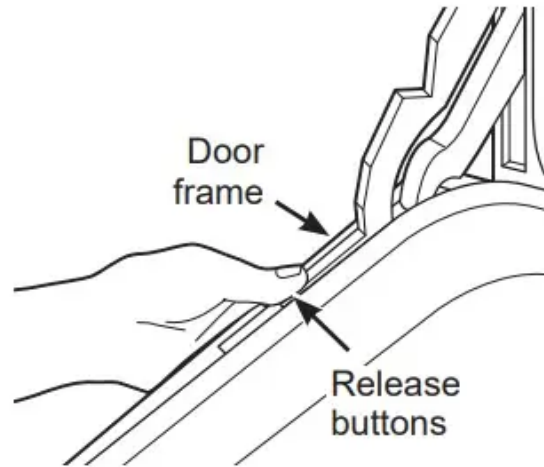
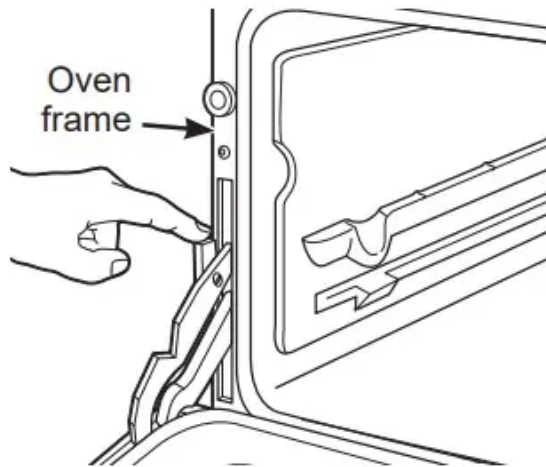

To

Replace the Door:

1. Pull the hinges down away from the oven frame to the fully open position.
2. Lift up on the hinge locks toward the oven frame until they stop.
3. The hinges will release to the 45-degree position. The hinge locks will contact the oven frame.
4. Slide the door back onto the hinges. Make sure the buttons pop back out.
5. Fully open the door.
6. Push the hinge locks down onto the hinge.
7. Close the oven door.

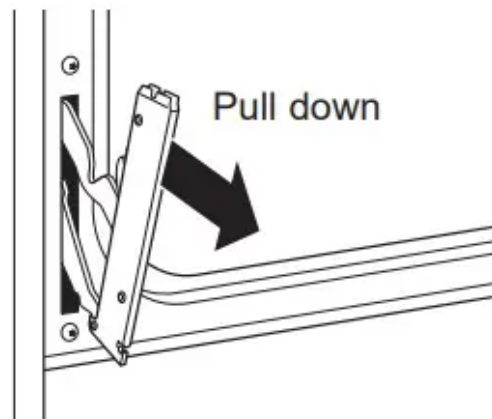
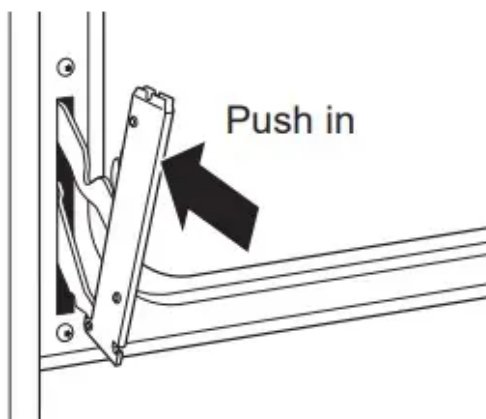

Troubleshooting tips ...

Before you call for service

Save time and money! Review the charts on the following pages first and you may not need to call for service.

- **My new oven doesn't cook like my old one. Is something wrong with the temperature settings?**

- Your new oven has a different cooking system from your old oven and therefore may cook differently than your old oven
 - For the first few uses, follow your recipe times and temperatures carefully. If you still think your new oven is too hot or too cold, you can adjust the temperature yourself to meet your specific cooking preference.

- **Food does not bake or roast (in the upper oven) properly**

- Oven controls improperly set.
 - See the Cooking Modes section
- Rack position is incorrect or rack is not level
 - See the Cooking Modes section and Cooking Guide
- Incorrect cookware or cookware of improper size being used
 - See the Cookware section
- Oven temperature needs adjustment.
 - See the Special Features section
- Ingredient substitution
 - Substituting ingredients can change the recipe outcome.

- **Food does not broil properly**

- Oven controls improperly set.
 - Make sure you select the appropriate broil mode.
- Oven door not closed.
- Improper rack position being used.
 - See Cooking Guide for rack location suggestions.
- Food being cooked in a hot pan.
 - Make sure cookware is cool.
- Cookware not suited for broiling.
 - Use a pan specifically designed for broiling.

- Aluminum foil used on the broiling pan and grid has not been fitted properly and slit as recommended.
 - If using aluminum foil conform to pan slits.
- In some areas the power (voltage) may be low.
 - Preheat the broil element for 10 minutes.
- **Upper or lower oven temperature too hot or too cold**
 - Oven temperature needs adjustment.
 - See the Special Features section.
- **Oven does not work or appears not to work**
 - A fuse in your home may be blown or the circuit breaker tripped.
 - Replace the fuse or reset the circuit breaker.
 - Oven controls improperly set.
 - See the Using the Oven section.
 - Oven is in Sabbath Mode.
 - Verify, that the oven is not in Sabbath Mode. See the Special Features section.
 - Heating elements turn off when door is open.
 - This is normal.
- **Crackling” or popping” sound**
 - This is the sound of the metal heating and cooling during both the cooking and cleaning functions.
 - This is normal.
- **Why is my range making a "clicking" noise when using my oven?**
 - Your range has been designed to maintain a tighter control over your oven's temperature. You may hear your oven's heating elements click" on and off more frequently than in older ovens to achieve better results during baking, broiling, and self-clean cycles.
 - This is normal.
- **Clock and timer do not work**
 - A fuse in your home may be blown or the circuit breaker tripped.
 - Replace the fuse or reset the circuit breaker.

- **Sometimes the oven takes longer to preheat to the same temperature**
 - Cookware or food in oven
 - The cookware or food in the oven will cause the oven to take longer to preheat. Remove items to reduce preheat time.
 - Number of racks in oven
 - Adding more racks to the oven will cause the oven to take longer to preheat. Remove some racks.
- **Upper or lower oven light does not work**
 - Light bulb is loose or defective.
 - Tighten or replace bulb.
 - Pad operating light is broken.
 - Call for service.
- **Upper or lower oven will not self-clean**
 - The temperature is too high to set a self-clean operation.
 - Allow the oven to cool and reset the controls.
 - Oven controls improperly set.
 - See the Cleaning the Oven section.
- **Excessive smoking during clean cycle**
 - Excessive soil or grease..
 - Press the Clear/Off pad. Open the windows to rid the room of smoke. Wait until the LOCKED DOOR light goes off. Wipe up the excess soil and reset the clean cycle.
- **Excessive smoking during broiling**
 - Food too close to burner element.
 - Lower the rack position of the food.
- **Oven door will not open after a clean cycle**
 - Oven too hot.
 - Allow the oven to cool below locking temperature.
- **Oven not clean after a clean cycle**
 - Oven controls improperly set.
 - See the Cleaning the Oven section.

- Oven was heavily soiled.
 - Clean up heavy spillovers before starting the clean cycle. Heavily soiled ovens may need to self-clean again or for a longer period of time.
- **"DOOR LOCK" flashes in the display**
 - The self-clean cycle has been selected but the door is not closed.
 - Close the oven door.
- **"LOCKED DOOR" light is on when you want to cook**
 - The oven door is locked because the temperature inside the oven has not dropped below the locking temperature.
 - Press the Clear/Off pad. Allow the oven to cool.
- **F— and a number or letter" flash in the display**
 - You have a function error code.
 - Press the Clear/Off pad. Allow the oven to cool for one hour. Put the oven back into operation.
 - If the function code repeats.
 - Disconnect all power to the oven for at least 30 seconds and then reconnect power. If the function error code repeats, call for service
- **Display goes blank**
 - A fuse in your home may be blown or the circuit breaker tripped.
 - Replace the fuse or reset the circuit breaker.
 - The clock is turned off.
 - See the Special features section.
 - Oven is in Sabbath Mode.
 - Verify that the oven is not in Sabbath Mode. See the Special Features section.
- **Power outage, clock flashes**
 - Power outage or surge
 - Reset the clock. If the oven was in use, you must reset it by pressing the Clear/Off pad, setting the clock and resetting any cooking function

- **Burning” or “oily” odor emitting from the vent**

- This is normal in a new oven and will disappear in time.
 - To speed the process, set a self-clean cycle for a minimum of 3 hours. See the Cleaning the Oven section. This is temporary.

- **Strong odor**

- An odor from the oven insulation is normal for the first few times the oven is used.
 - This is temporary and will go away after several uses or a self-clean cycle.

- **My oven door glass appears to be "tinted" or have a "rainbow" color. Is this defective?**

- No. The inner oven glass is coated with a heat barrier to reflect the heat back into the oven to prevent heat loss and keep the outer door cool while baking.
 - This is normal. Under certain light or angles, you may see this tint or rainbow color.

- **Top burners do not light or do not burn evenly. (The front right burner is designed to have slightly smaller flames between the 6 and 9 o'clock positions. This is normal.)**

- Plug on range is not completely inserted in the electrical outlet.
 - Make sure electrical plug is plugged into a live, properly grounded outlet.
- Burner slits on the side of the burner may be clogged.
 - Remove the burners and clean them. Check the electrode area for burned-on food or grease. See the Care and cleaning of the range section.
- Improper burner assembly..
 - Make sure the burner parts are installed correctly. See the Care and cleaning of the range section.

- **Burner flames very large or yellow**

- Improper air to gas ratio
 - If range is connected to LP gas, contact the person who installed your range or made the conversion

- **Surface burners light but oven does not**

- The oven gas shut-off valve may have accidentally been moved during cleaning or moving.
 - To check the oven gas shut-off valve, remove the drawer (see the Care and cleaning of the Range section). For lower oven drawer models, remove the rear access panel by unscrewing the thumb screws in the upper left and right corners. Look for the gas shut-off lever at the back of the range.

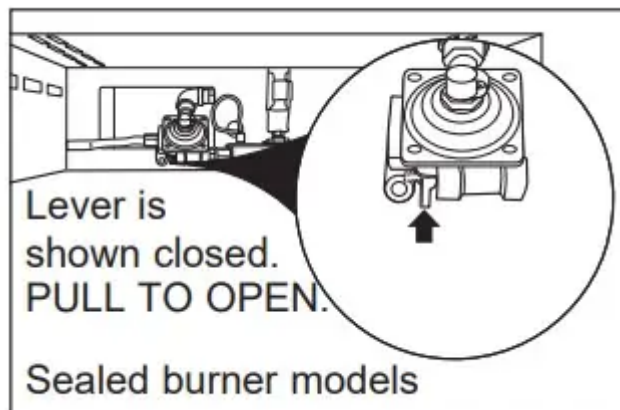

- **Burners do not light**

- Plug on range is not completely inserted in the electrical outlet.
 - Make sure electrical plug is plugged into a live, properly grounded outlet.
- Gas supply not connected or turned on.
 - See the Installation Instructions that came with your range
- A fuse in your home may be blown or the circuit breaker tripped.
 - Replace the fuse or reset the circuit breaker.
- Burner parts not replaced correctly.
 - See the Care and Cleaning of the range section.

- **Lock Controls or Control Lockout feature is activated**

- If LOC ON appears in the display, the range control is locked. Turn this feature off to use the range. See the Lock Control feature in the Oven Controls section.

- **Control signals after entering cooking time or start time**

- You forgot to enter a bake temperature or cleaning time.
 - Touch the Bake pad and desired temperature or the Self Clean pad and desired clean time.

- **Close Door” scrolls in the display when BROIL is set**
 - The display will always automatically remind you to close the door.
 - This is a normal reminder to close the door when broiling.
- **Probe” appears in the display**
 - This is reminding you to enter a probe temperature after plugging in the probe.
 - Enter a probe temperature.
- **LOC appears in display**
 - The Gas/Control Lockout feature is activated
 - Be sure the surface burner controls are turned OFF. Turn this feature off to use the range. See the Gas/Control Lockout section.
- **Fan noise**
 - The convection fan may turn on and off automatically.
 - This is normal. The convection fan will run until the function is over or the door is opened.
- **Convection fan not working**
 - Preheat temperature not reached.
 - Fan will start automatically once the preheat temperature is reached

Warning

This content is compiled from multiple sources and is provided for reference purposes only. It may not be complete or fully applicable to all situations. If you are unable to resolve your issue, please contact the product manufacturer or an authorized service provider for official support.