

FEATURES AT A GLANCE - BASELINE MODEL

*Features may vary according to model

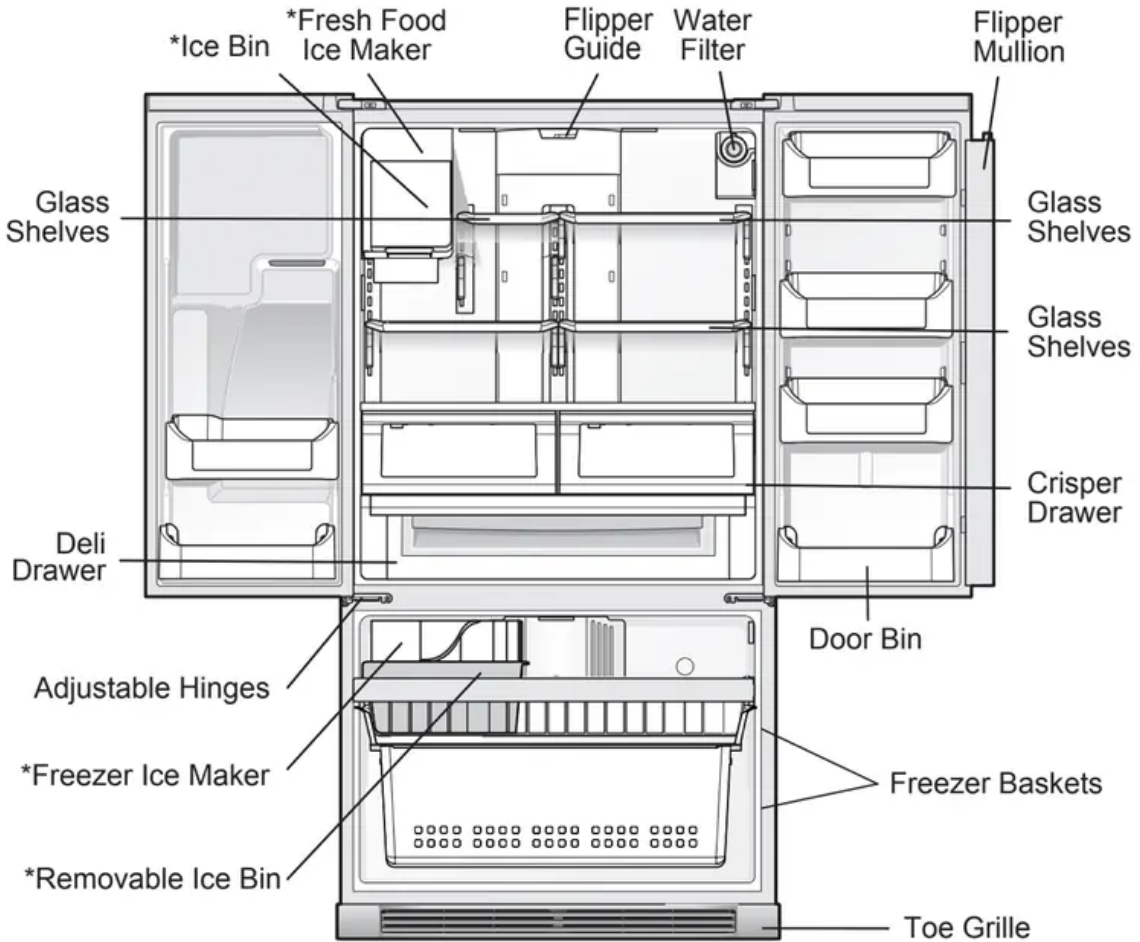

FEATURES AT A GLANCE - GALLERY MODEL

*Features may vary according to model



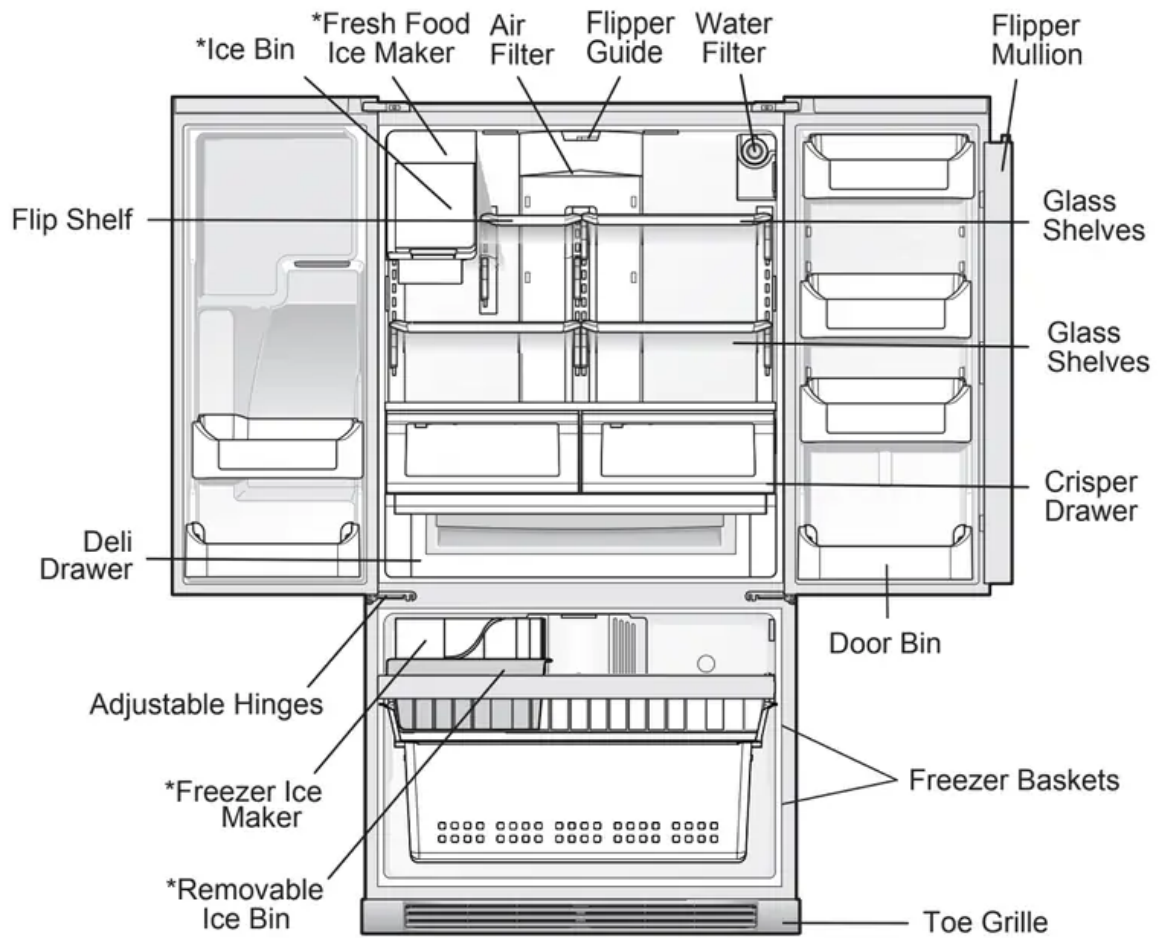

FEATURES AT A GLANCE - PRO MODEL

*Features may vary according to model

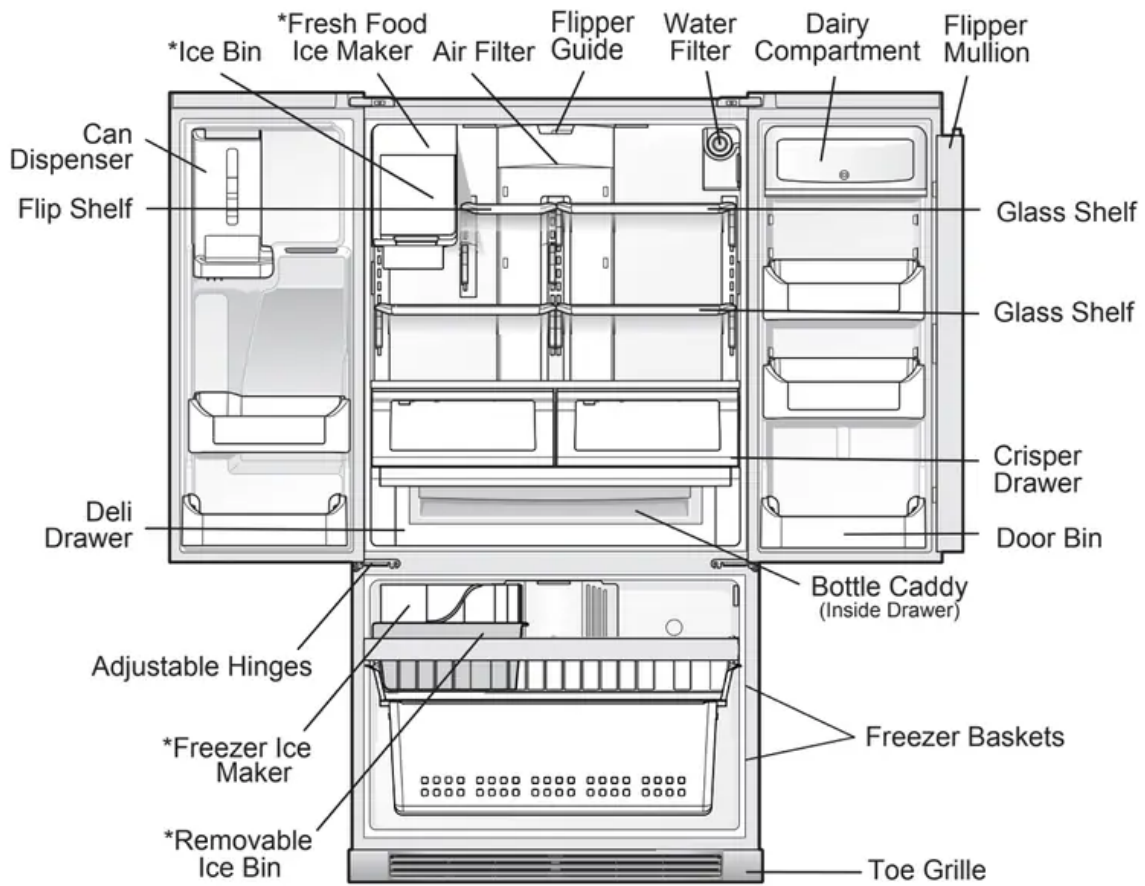

CONTROLS - FRIGIDAIRE & FRIGIDAIRE GALLERY DISPENSER

User Interface (colors and options may vary by model)

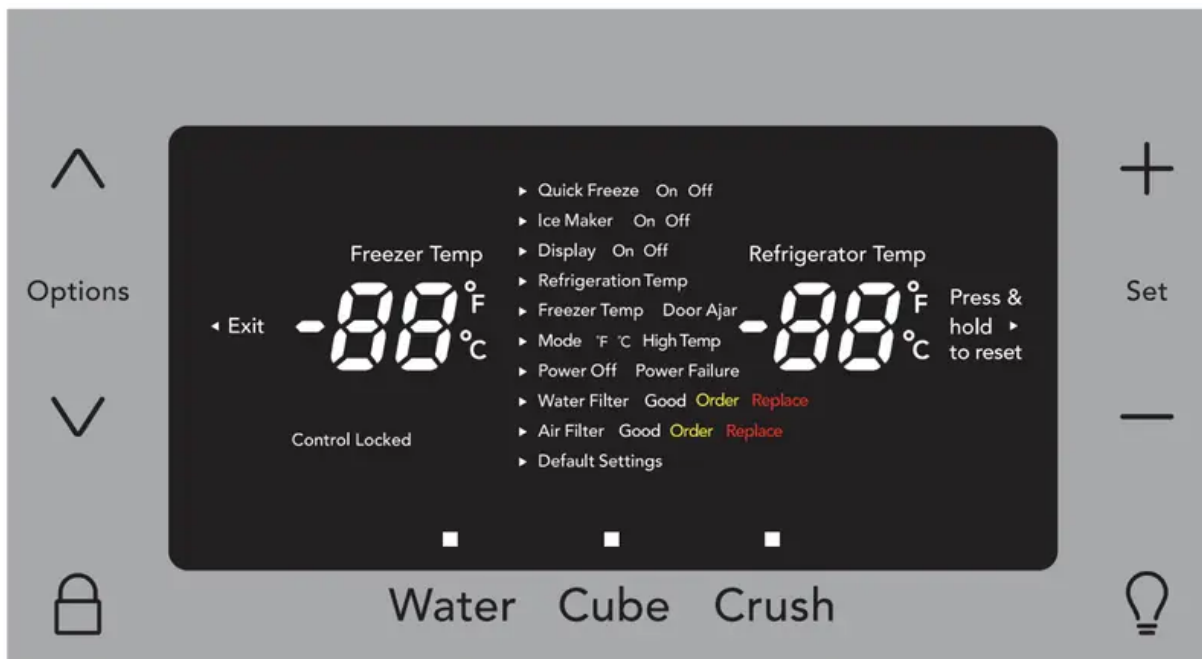

Enlarged view of above user interface display menu (colors and options may vary by model)

The image shows a simulated refrigerator control panel with a black background and white text. On the right side, there is a digital display showing '00' in a large, segmented font. Above the display is the text 'Refrigerator Temp'. To the right of the display are the units '°F' and '°C'. A small white arrow points to the left of the display. The menu items are listed on the left side of the panel:

- ▶ Quick Freeze On Off
- ▶ Ice Maker On Off
- ▶ Display On Off
- ▶ Refrigeration Temp
- ▶ Freezer Temp Door Ajar
- ▶ Mode °F °C High Temp
- ▶ Power Off Power Failure
- ▶ Water Filter Good Order Replace
- ▶ Air Filter Good Order Replace
- ▶ Default Settings

Options May Vary



<p>Options (^ or v)</p>	<p>Used to enter and exit the options menu and make selections.</p>
<p>Exit</p>	<p>Toggles the options and run modes.</p>
<p>Control Locked</p> 	<p>While in the locked state, you will not be able to change any settings on the display nor dispense ice and water. The "Control Locked" indicator will flash and an audible warning tone is played.</p>
<p>Quick Freeze On Off</p>	<p>Activates a faster rate for freezing food and increases ice production in the freezer. Deactivates after 12 hours.</p>
<p>Ice Maker On Off</p>	<p>Toggles the ice maker in the refrigerator compartment "ON" or "OFF". In the "Off" state, the indicator will blink when ice is dispensed.</p>
<p>Display On Off</p>	<p>Toggles the display of the temperature settings On and Off.</p>
<p>Refrigeration Temp</p>	<p>Allows the temperature set-points to be adjusted. Control temperatures range from +33°F / +1°C to +47°F / +8°C.</p>

Freezer Temp

Allows the temperature set-points to be adjusted. Control



Mode
°F °C

Toggles display from Fahrenheit to Celsius.

Light



Toggles dispenser light On and Off.

Power Off

Press and hold for three seconds to turn off the cooling system. It also turns off the ice maker and all dispenser functions. The display will read "power off".

Water Filter

Displays the current status of the water filter (Good, Order, or Replace). To reset the filter status to "Good", press and hold the "set" key for three seconds.

Air Filter

Displays the current status of the air filter (Good, Order, or Replace). To reset the filter status to "Good", press and hold the "set" key for three seconds.

Default Settings

While in the default option, press and hold the "set" key for three seconds to reset all refrigerator settings to their factory default settings.

Set (+ or -)

Selects the current menu selection option.

Water

Press the "water" key to select water. An indicator light will be illuminated above the active feature.

Cube

Press the "cube" key to select cubed ice. An indicator light will be illuminated above the active feature.

Crush

Press the "crush" key to select crushed ice. An indicator light will be illuminated above the active feature.

Setting cooling temperatures (options may vary)

NOTE: The recommended settings for a product installed in a kitchen is 37°F for the fresh food compartment and 0°F for the freezer.

IMPORTANT: If your product has food freezing in the fresh food compartment, increase the temperature setting 1 or 2 degrees.

IMPORTANT: If you place food within 1 inch in front of the air ports, there may be the chance of freezing food.

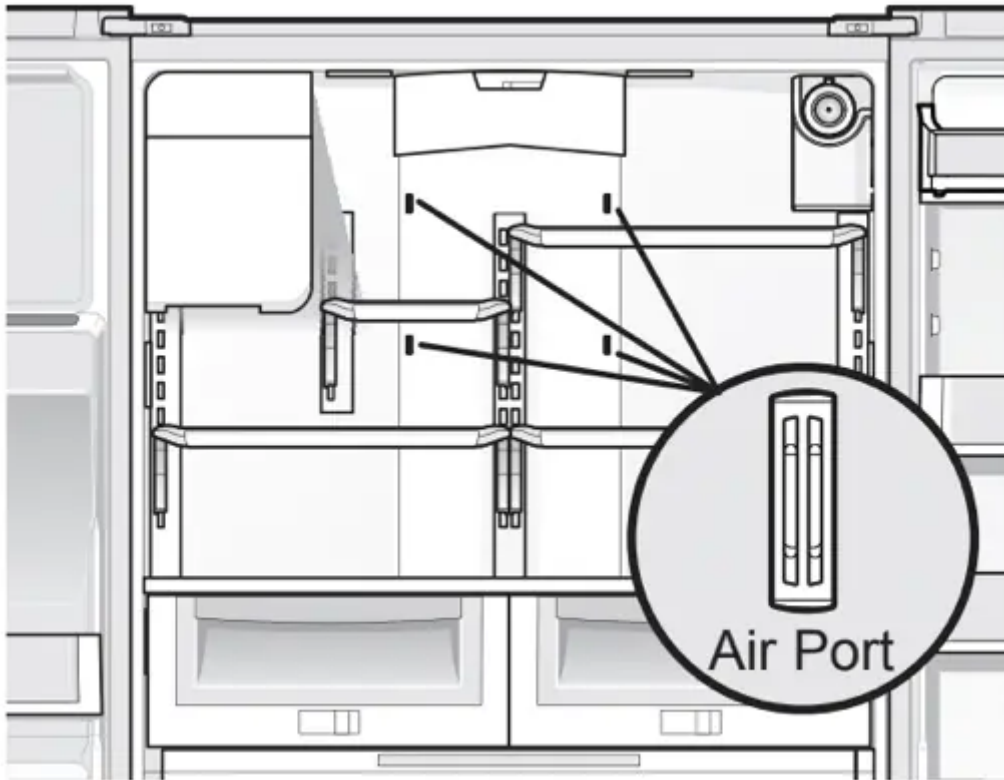

NOTE: Control features and alarms may vary by model.

Alarms

Power Failure

In the event of a power failure, the power fail alert will be illuminated. Press set to acknowledge the alarm. Other modes may be turned off until the alarm is acknowledged. While a power fail alert is displayed on the control panel, the unit will continue normal operation. The power fail alert on the control panel will be removed once the user acknowledges the power fail condition by pressing any key on the control panel. The high temp alarm may also be illuminated until a safe operating range temperature has been reached.

Freezer Temp

If the freezer temperature reaches 26°F or greater, the alarm will sound and the temperature will flash. You can disable the alarm by pressing the set key but the "High Temp" indicator will illuminate until the temperature goes below 26°F.

Fresh Food Temp

If the fresh food temperature reaches 55°F or greater, the alarm will sound and the temperature will flash. You can disable the alarm by pressing the set key but the "High Temp" indicator will illuminate until the temperature goes below 55°F.

Door Ajar

If the freezer or fresh food doors have been left open for five minutes or more, an alarm will sound and the door ajar indicator will illuminate on the display. Press the set key to reset any system alarms.

Flapper

When “Cube” or “Crush” is selected, if the flapper (or ice chute door) is being held open by a jammed ice cube, an alarm will sound for two minutes. The alarm will reset after two minutes or when the ice cube is removed and the set key is pressed to reset.

Sabbath Mode

The Sabbath Mode is a feature that disables portions of the refrigerator and its controls in accordance with observance of the weekly Sabbath and religious holidays within the Orthodox Jewish community.

Sabbath Mode is turned ON and OFF by simultaneously pressing and holding both the “v” and “+” for five seconds. The display shows “Sb” while in Sabbath mode.

In the Sabbath Mode, the High Temp alarm is active for health reasons. For example, if the door is left ajar the High Temp alarm is activated. The refrigerator will function normally once the door is closed, without any violation of the Sabbath/Holidays. The High Temp alarm is permitted when cabinet temperature is outside the safe zone for 20 minutes. The alarm silences itself after 10 minutes while the High Temp icon stays lit until the Sabbath mode is exited.

NOTE:

- While in Sabbath Mode, neither the lights, dispenser, nor the control panel will work until Sabbath Mode is deactivated.
- Refrigerator stays in Sabbath Mode after power failure recovery. It must be deactivated with the buttons on the control panel.

NOTE: Although you have entered the Sabbath Mode, the ice maker will complete the cycle it had already initiated. The ice cube compartment will remain cold and new ice cubes can be made with standard trays.

CONTROLS - NON-DISPENSER MODELS



Press & Hold

Hold to Reset

Power
On-Off

Default
Settings



Quick
Ice

Quick
Freeze

Press & Hold

 Good

Air
Filter

 Order

 Replace

Hold to Reset

 Good

Water
Filter

 Order

 Replace

 Door Ajar

Alert
Reset

 High Temp

 Power Fail

User Interface In-Door Controls (options may vary)

IMPORTANT: Pressing the system on/off icon does not turn off power to your refrigerator. You must unplug the power cord from the wall outlet.

An indicator light will be illuminated above most active features.

Touch the icon to activate the options below.

Power On Off	Press and hold for three seconds to turn off the cooling system to clean the refrigerator. The digital displays will read OFF.
Default Settings	Resets all refrigerator settings such as temp, temp display and tones to their factory default settings.
Quick Freeze	Activates a faster rate for freezing food.
Quick Ice	Temporarily increases cooling for freezer to increase the production of ice
Air Filter	Filter condition status is always displayed when door is open. Press and hold for three seconds to reset after filter change.
Water Filter	Press and hold for three seconds to reset after filter change.
Alert Reset	Tones emitted by each key press can be turned off based on user preference. The sounds are muted when the red indicator is lit. Warning signals will stay active.
F/C	Touch to toggle display from Fahrenheit to Celsius.

Setting cooling temperatures

Press the + or – indicator to adjust the temperature to the desired setting.

The temperature setting will begin to blink with the first touch. The display will time out after 10 seconds and return to the basic display.

NOTE: The recommended settings for a product installed in a kitchen is 37°F for the fresh food compartment and 0°F for the freezer.

Alarms

- Door Ajar
 - If the door has been left open for an extended period of time, an alarm will sound and the door ajar indicator will display on the bottom display of the control panel. The alarm is turned off by closing the door. The alert reset key will blink to prompt the reset of any active alarms. Press this key to reset any system alarms.
- High Temp
 - In the event of a high temperature condition, the temperature display will blink and display “HI”. After 20 minutes, the alarm will sound and the high temp indicator will be red on the bottom of the control panel. Upon acknowledging the alarm, the highest temperature reached will be displayed and the refrigerator will resume normal operation. In case the high temp alarm is not acknowledged at the first alarm sound time out, when the door is first opened, the alarm sound will be repeated.
- Power Fail
 - In the event of a power failure, the power fail alert will be displayed and the temperature display will blink until the alert reset icon is pressed, acknowledging the alarm. Other modes may be turned off until the alarm is acknowledged. The power fail alert is turned off and the refrigerator will resume normal operation. The high temp alarm may also be illuminated until a safe operating range temperature has been reached.

“Sabbath Mode”

The Sabbath Mode is a feature that disables portions of the refrigerator and its controls for, in accordance with observance of the weekly Sabbath and religious holidays within the Orthodox Jewish community.

Sabbath Mode is turned ON and OFF by simultaneously pressing and holding the freezer temp “-” and the refrigerator temp “+” indicators for five seconds. The display shows “Sb” while in Sabbath mode.

In the Sabbath Mode, the High Temp alarm is active for health reasons. For example, if the door is left ajar the High Temp alarm is activated. The refrigerator will function normally once the door is closed, without any violation of the Sabbath/Holidays. The High Temp alarm is permitted when cabinet temperature is outside the safe zone for 20 minutes. The alarm silences itself after 10 minutes while the High Temp icon stays lit until the Sabbath mode is exited.

NOTE:

- While in Sabbath Mode, neither the lights nor the control panel will work until Sabbath Mode is deactivated.
- Refrigerator stays in Sabbath Mode after power failure recovery. It must be deactivated with the buttons on the control panel.

NOTE: During Sabbath Mode, the freezer ice maker will continue to work and must be manually turned off to be compliant with the Sabbath observances.

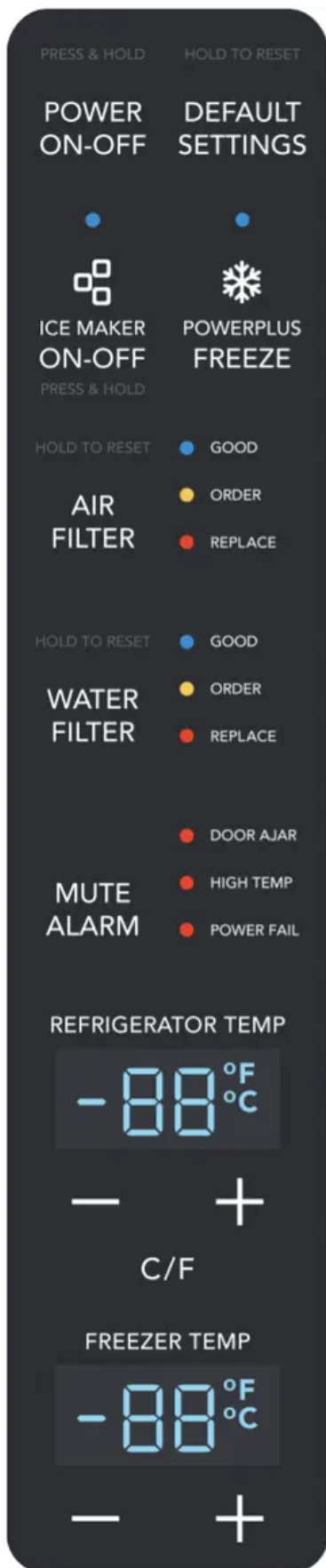

POWER ON-OFF

Press and hold for three seconds to turn off the cooling system. It also turns off the ice maker and all dispenser functions. The display will read "OFF".

DEFAULT SETTINGS

Press and hold for three seconds to reset all refrigerator settings to their factory default settings.

ICE MAKER ON-OFF

The Ice Maker is on if the LED above the Icon is illuminated. Ice dispensing will still function. Press and hold the button for 3 seconds to toggle the Ice Maker on and off.

POWERPLUS FREEZE

Activates a faster rate for freezing food and increases ice production in the freezer. Deactivates after 12 hours.

AIR FILTER

Displays the current status of the air filter (GOOD, ORDER, or REPLACE). To reset the filter status to "GOOD", press and hold for three seconds.

WATER FILTER

Displays the current status of the water filter (GOOD, ORDER, or REPLACE). To reset the filter status to "GOOD", press and hold for three seconds.

MUTE ALARM

Tones emitted by each key press can be turned off based on user preference. The sounds are muted when the red indicator is lit. Warning signals will stay active.

REFRIGERATOR TEMP

Allows the temperature set-points to be adjusted. Press the "-" or "+" indicator to adjust the temperature to the desired setting. Control temperatures range from +33°F / +1°C to +47°F / +8°C.

FREEZER TEMP

Allows the temperature set-points to be adjusted. Press the "-" or "+" indicator to adjust the temperature to the desired setting. Control temperatures range from -6°F / -21°C to +6°F / -15°C.

C/F

Toggles display between Celsius and Fahrenheit.



CONTROLS - FRIGIDAIRE PROFESSIONAL

Dispenser Controls (options may vary)

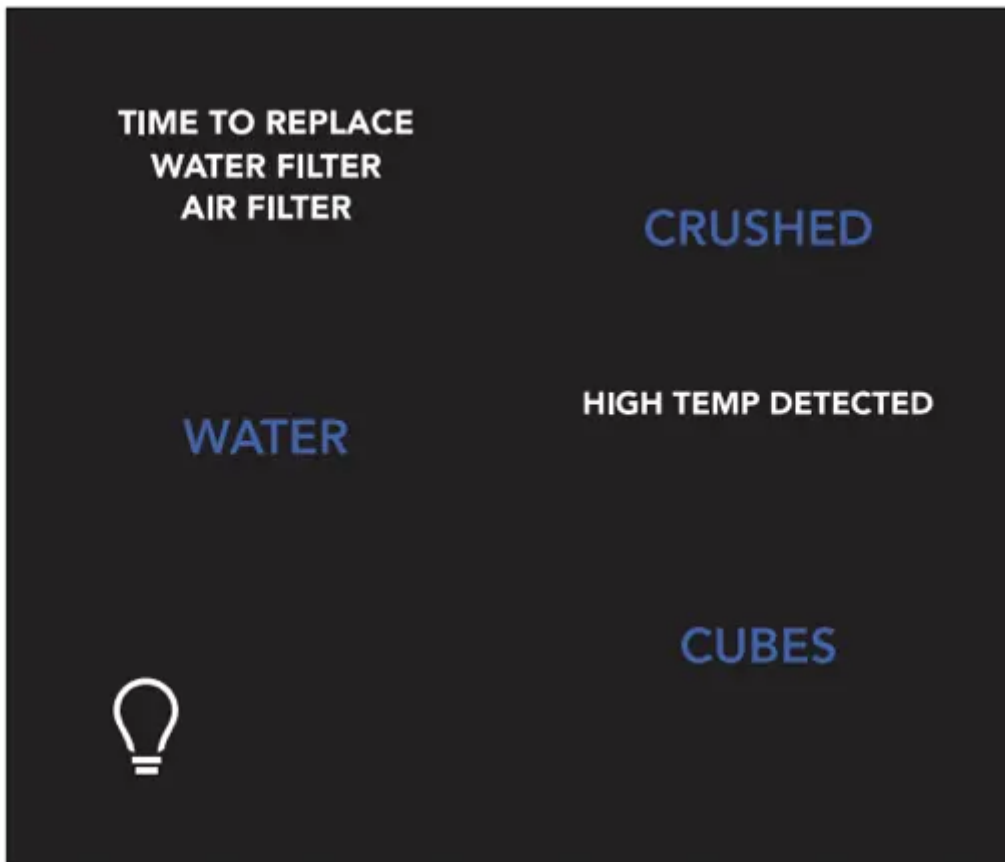

WATER

Press the "WATER" key to select water.

CUBES

Press the "CUBES" key to select cubed ice.

CRUSHED

Press the "CRUSHED" key to select crushed ice.



light

Toggles dispenser light on and off.

Alarms

Power Failure

In the event of a power failure, the power fail alert will be illuminated. Press “mute alarm” to acknowledge the alarm. Other modes may be turned off until the alarm is acknowledged. While a power failure alert is displayed on the control panel, the unit will continue normal operation. The power fail alert on the control panel will be removed once the user acknowledges the power fail condition by pressing any key on the control panel. The high temp alarm may also be illuminated until a safe operating range temperature has been reached.

Freezer Temp

If the freezer temperature reaches 26°F or greater, the alarm will sound and the temperature will flash and the dispenser control will display “HIGH TEMP DETECTED”. You can disable the alarm by pressing “mute alarm” but the “HIGH TEMP DETECTED” indicator will illuminate until the temperature goes below 26°F.

Fresh Food Temp

If the fresh food temperature reaches 55°F or greater, the alarm will sound and the temperature will flash and the dispenser control will display “HIGH TEMP DETECTED”. You can disable the alarm by pressing “mute alarm” but the “HIGH TEMP DETECTED” indicator will illuminate until the temperature goes below 55°F.

Door Ajar

If the freezer or fresh food doors have been left open for five minutes or more, an alarm will sound and the door ajar indicator will illuminate on the display. Press “mute alarm” to reset any system alarms.

Flapper

When “CUBES” or “CRUSHED” is selected, if the flapper (or ice chute door) is being held open by a jammed ice cube, an alarm will sound for two minutes and the current selection will blink on the dispenser control. The alarm will reset after two minutes or when the ice cube is removed.

Sabbath Mode

The Sabbath Mode is a feature that disables portions of the refrigerator and its controls in accordance with observance of the weekly Sabbath and religious holidays within the Orthodox Jewish community.

Sabbath Mode is turned ON and OFF by simultaneously pressing and holding both the freezer “-” and the refrigerator “+” for five seconds. The display shows “Sb” while in Sabbath mode.

In the Sabbath Mode, the High Temp alarm is active for health reasons. For example, if the door is left ajar the High Temp alarm is activated. The refrigerator will function normally once the door is closed, without any violation of the Sabbath/Holidays. The High Temp alarm is permitted when

cabinet temperature is outside the safe zone for 20 minutes. The alarm silences itself after 10 minutes while the High Temp icon stays lit until the Sabbath mode is exited.

NOTE:

- While in Sabbath Mode, neither the lights, dispenser, nor the control panel will work until Sabbath Mode is deactivated.
- Refrigerator stays in Sabbath Mode after power failure recovery. It must be deactivated with the buttons on the control panel.

NOTE: Although you have entered the Sabbath Mode, the ice maker will complete the cycle it had already initiated. The ice cube compartment will remain cold and new ice cubes can be made with standard trays.

NOTE: During Sabbath Mode, the freezer ice maker will continue to work and must be manually turned off to be compliant with the Sabbath observances.

AUTOMATIC ICE & WATER DISPENSER

Priming the water supply system

CAUTION: For proper dispenser operation, recommended water supply pressure should fall between 30 psi and 100 psi. Excessive pressure may cause the system to malfunction.

1. Begin filling the system by pressing and holding a drinking glass against the water dispenser paddle.
2. Keep the glass in this position until water comes out of the dispenser. It may take about 1 1/2 minutes.
3. Continue dispensing water for about four minutes to flush the system and plumbing connections of any impurities (stopping to empty the glass as necessary).



Dispenser (varies by model)

NOTE: The water dispenser has a built-in device that shuts off the water flow after three minutes of continuous use. To reset this shutoff device, simply release the dispenser paddle.

NOTE: Dispensed water is not chilled. For colder water, add ice to cup or container before dispensing water.

Ice maker operation & care

After the refrigerator is installed properly and has cooled for several hours, the ice maker can produce ice within 24 hours. The ice maker will fill the ice bin from the rear. You must dispense some ice to force the ice forward in the bin. This will allow the bin to fill completely.

Ice Maker and Storage Bin Capacity

This ice maker should produce 2.0 to 2.5 pounds of ice per 24 hours.

In a Standard Depth model, the ice bin will hold about 6.5 pounds of ice. In a Counter Depth model, the ice bin will hold about 4 pounds of ice.

Turning the fresh food ice maker on and off

Ice production is controlled by the ice maker's On/Off feature on the control panel. Pressing the On/Off feature turns the ice maker on & off.

IMPORTANT: Turning off the ice maker simply disables ice making. You will still be able to dispense existing ice, and you will still be able to dispense water.

NOTE: The ice maker also has a built-in plastic signal arm that automatically stops ice production when the ice bin is full. This signal arm should not be used to manually stop the ice maker.

Using the ice maker after installation

Before making ice for the first time, be sure to prime the water supply system. Air in new plumbing lines can result in two or three empty ice maker cycles. Furthermore, if the system is not flushed, the first ice cubes may be discolored or have an odd flavor.

IMPORTANT: Your ice maker is turned on at the factory so it can work as soon as you install your refrigerator. If you cannot connect a water supply, set the ice maker's On/Off feature to Off; otherwise, the ice maker's fill valve may make a loud chattering noise when it attempts to operate without water.

IMPORTANT: On occasion, unusually small ice cubes may be noticed in the bucket or in dispensed ice. This could occur in normal operation of the ice maker. If you start seeing these more frequently, it may be an indication of low water pressure or the water filter needs to be replaced. As the water filter nears the end of its useful life and becomes clogged with particles, less water is delivered to the ice maker during each cycle. Remember, if it's been six months or longer since you last changed your water filter, replace the water filter with a new one. Poor quality household water may require the filter to be changed more frequently.

AUTOMATIC ICE & WATER DISPENSER

Ice maker/dispenser tips

- If your refrigerator is not connected to a water supply or the water supply is turned off, turn off the ice maker as described in the previous section.
- The following sounds are normal when the ice maker is operating:
 - Motor running
 - Ice dropping into ice bin
 - Water valve opening or closing
 - Running water
- If you need a large quantity of ice at one time, it is best to get cubes directly from the ice bin.
- Ice cubes stored too long may develop an odd flavor. Empty the ice bin as explained below.
- When dispensing cubed ice, it is normal to have a small quantity of little pieces along with the whole cubes.

- To avoid splashing, dispense ice into your container before adding liquids.
- It is normal for ice to fill to the top of the ice bin.

CAUTION: If the water supply to your refrigerator is softened, be sure the softener is properly maintained. Chemicals from a water softener can damage the ice maker.

Cleaning the ice maker

Clean the ice maker and ice bin at regular intervals, especially prior to vacation or moving.

1. Turn off the ice maker.
2. Remove the ice bin by pulling straight out.
3. Empty and carefully clean the ice bin with mild detergent. Do not use harsh or abrasive cleaners. Rinse with clear water.
4. Allow the ice bin to dry completely before replacing in the freezer.
5. Replace the ice bin. Turn the ice maker on.

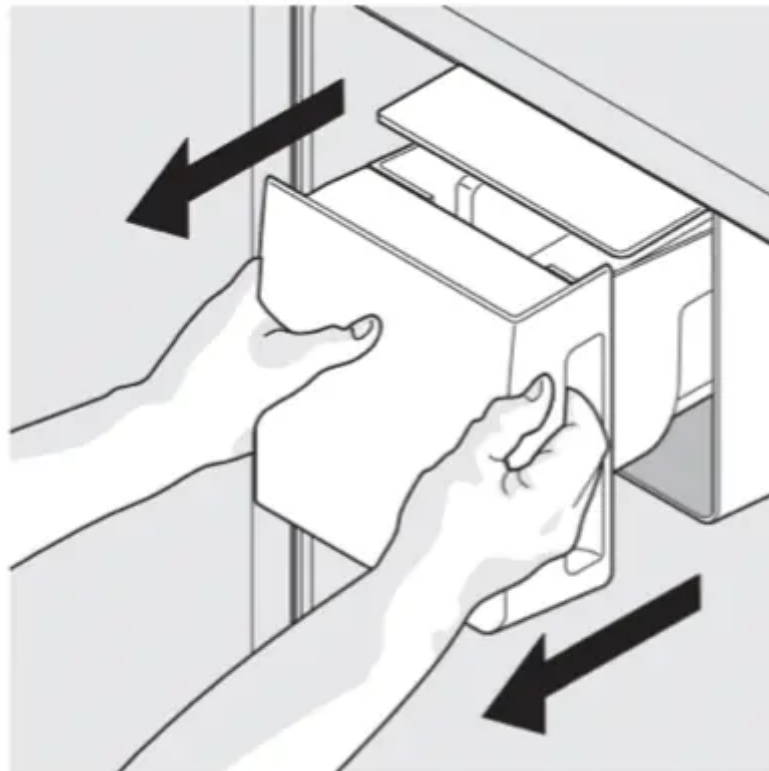

Removing Ice Bin

Remove and empty the ice bin if:

- An extended power failure (one hour or longer) causes ice cubes in the ice bin to melt and refreeze together after power is restored, jamming the dispenser mechanism.
- You do not use the ice dispenser frequently. Ice cubes will freeze together in the bin, jamming the dispenser mechanism.

Remove the ice bin and shake to loosen the cubes or clean as explained above.

CAUTION:

- NEVER use an ice pick or similar sharp instrument to break up the ice. This could damage the ice bin and dispenser mechanism.
- To loosen stuck ice, use warm water.
- Before replacing the ice bin, make sure it is completely dry.

IMPORTANT: When removing or replacing the ice bin, avoid rotating the auger in the ice bin. If the auger is accidentally rotated, you must realign the auger by turning it in 45 degree turns (see below) until the ice bin fits into place with the drive mechanism. If the auger is not properly aligned when replacing the ice bin, the refrigerator will not dispense ice. The fresh food door also may not close properly causing warm air to leak into the fresh food compartment.

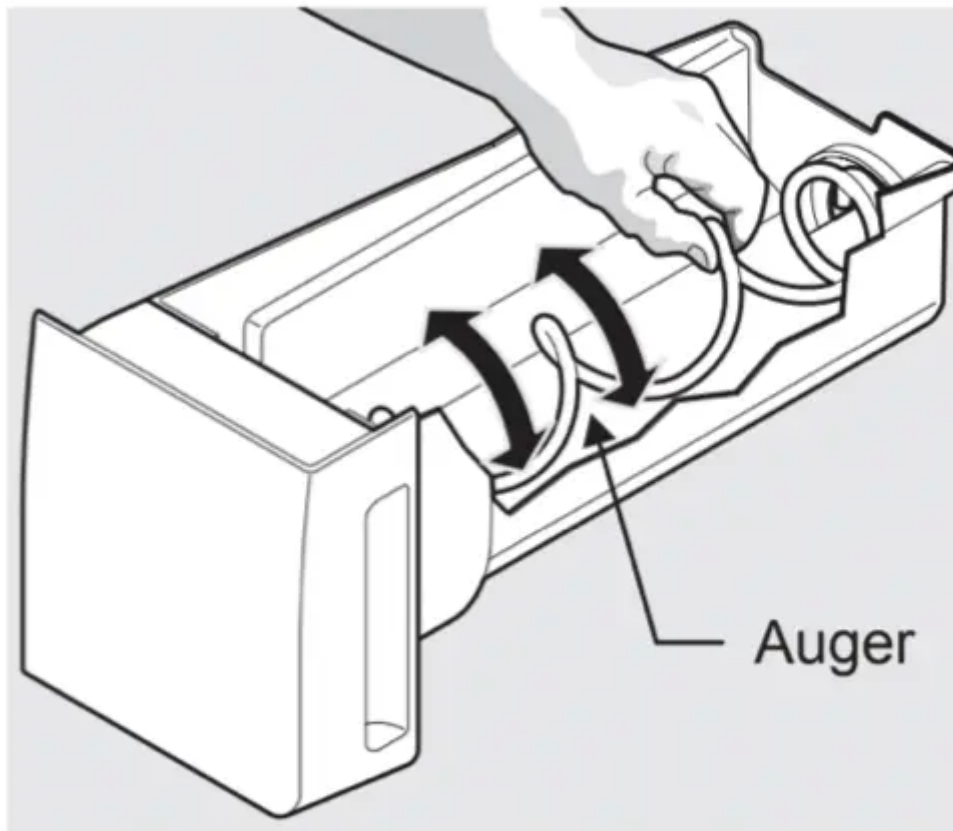

Adjusting Ice Bin Auger

AUTOMATIC ICE MAKER - FREEZER (SELECT MODELS)

Operation & Care of the Freezer Ice Maker (select models)

After the refrigerator is installed properly, the ice maker can produce ice within 24 hours. When using the ice maker for the first time, and in order for it to work properly, it is necessary to clear air

from the water tubing and the filter. Furthermore, if the system is not flushed, the first ice cubes may be discolored or have an odd flavor. Once the ice maker begins making ice, allow the bin to fill completely, then discard the first FULL bin of ice on a Standard Depth model, and the first TWO FULL bins of ice on a Counter Depth model.

Ice Maker and Storage Bin Capacity

This ice maker should produce between 2 and 2.5 pounds of ice per 24 hours depending on usage conditions. In a Standard Depth model, the ice bin will hold about 12 pounds of ice. In a Counter Depth model, the ice bin will hold about 7 pounds of ice.

IMPORTANT: Your ice maker is turned on at the factory so it can work as soon as you install your refrigerator. If you cannot connect a water supply, lift the ice maker's wire signal arm to turn it off. Otherwise, the ice maker's fill valve may make a loud chattering noise when it attempts to operate without water.

Turning the ice maker on and off

The ice maker is turned off and on by lifting/lowering the ice maker's wire signal arm. To gain access to the ice maker, pull the freezer drawer out. Lift the wire signal arm to turn the ice maker OFF and lower the wire signal arm to turn it ON.

Ice maker tips

- The following sounds are normal when the ice maker is operating:
 - Motor running
 - Ice dropping into ice bin
 - Water valve opening or closing
 - Running water
- Ice cubes stored too long may develop an odd flavor. Empty the ice bin as explained below.

Quick Freeze Function

Your refrigerator is equipped with a Quick Freeze Function for freezing food at a faster rate, but it can also increase ice production. This function terminates automatically after 12 hours. **This function affects only the ice maker in the freezer.**

CAUTION: If the water supply to your refrigerator is softened, be sure the softener is properly maintained. Chemicals from a water softener can damage the ice maker.

Cleaning the ice maker

Clean the ice maker and ice bin at regular intervals, especially prior to vacation or moving.

1. Turn off the ice maker.
2. Remove the ice bin.
3. Empty and carefully clean the ice bin with mild detergent. Do not use harsh or abrasive cleaners. Rinse with clean water.
4. Allow the ice bin to dry completely before replacing in the freezer.
5. Replace the ice bin. Turn the ice maker on.

Remove and empty the ice bin if an extended power failure (one hour or longer) causes ice cubes in the ice bin to melt and refreeze together after power is restored.

Remove the ice bin and shake to loosen the cubes or clean as explained above.

CAUTION:

- NEVER use an ice pick or similar sharp instrument to break up the ice. This could damage the ice bin.
- To loosen stuck ice, use warm water. Before replacing the ice bin, make sure it is completely dry.

STORAGE FEATURES

CAUTION: To avoid personal injury or property damage, handle tempered glass shelves carefully. Shelves may break suddenly if nicked, scratched, or exposed to sudden temperature change. Allow the glass shelves to stabilize to room temperature before cleaning. Do not wash in dishwasher.

NOTE: Features may vary according to model.

You can easily adjust shelf positions in the fresh food compartments to suit your needs. The shelves have mounting brackets that attach to slotted supports at the rear of each compartment.

Change the Position of a Shelf

1. Remove all food from shelf.
2. Lift the front edge up and pull the shelf out.
3. Replace by inserting the mounting bracket hooks into the desired support slots.
4. Lower the shelf and lock into position.

IMPORTANT: Be aware of the air seal located at the rear of the shelf. Shelves located on the left side should have the air seal mounted on the far left side. Shelves located on the right side should have the air seal mounted on the far right side. This is to ensure there is no interference with the large air tower on the back wall of the cabinet. This also applies to the crisper shelves.

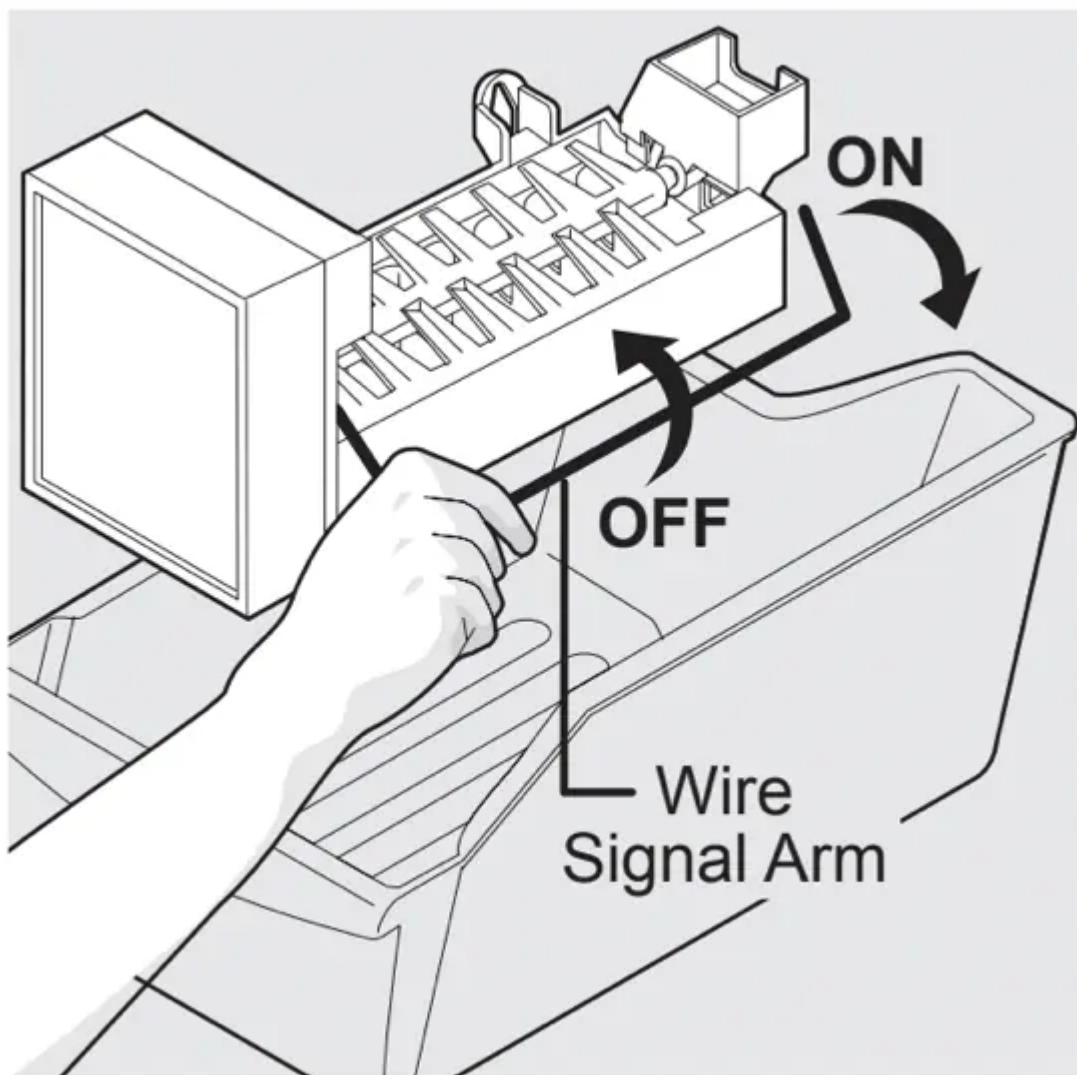

Reposition the Air Seal

For crisper shelves:

1. Remove air seal by pushing down on the flap with a downward rotation.
2. Position the air seal towards the outside end of the shelf to avoid the air tower when shelf is pushed back into place.
3. Install seal by sliding lower tab of seal up into bottom rear slot of shelf with seal at a downward angle then pulling up on seal flap until seal sits snug on back of shelf and flap sits at about a 10 degree angle from shelf surface.

For glass shelves:

1. Remove air seal by pushing seal straight back.
2. Position the air seal towards the outside edge of the shelf to avoid the air tower when shelf is pushed back into place.
3. Install seal by sliding the open channel end of the seal onto back edge of shelf until seal sits snug on back of shelf and flap sits at about a 10 degree angle from shelf surface.

Drawers

Your refrigerator includes a variety of storage drawers.

Crispers

Crisper drawers are designed for storing fruits, vegetables, and other fresh produce.

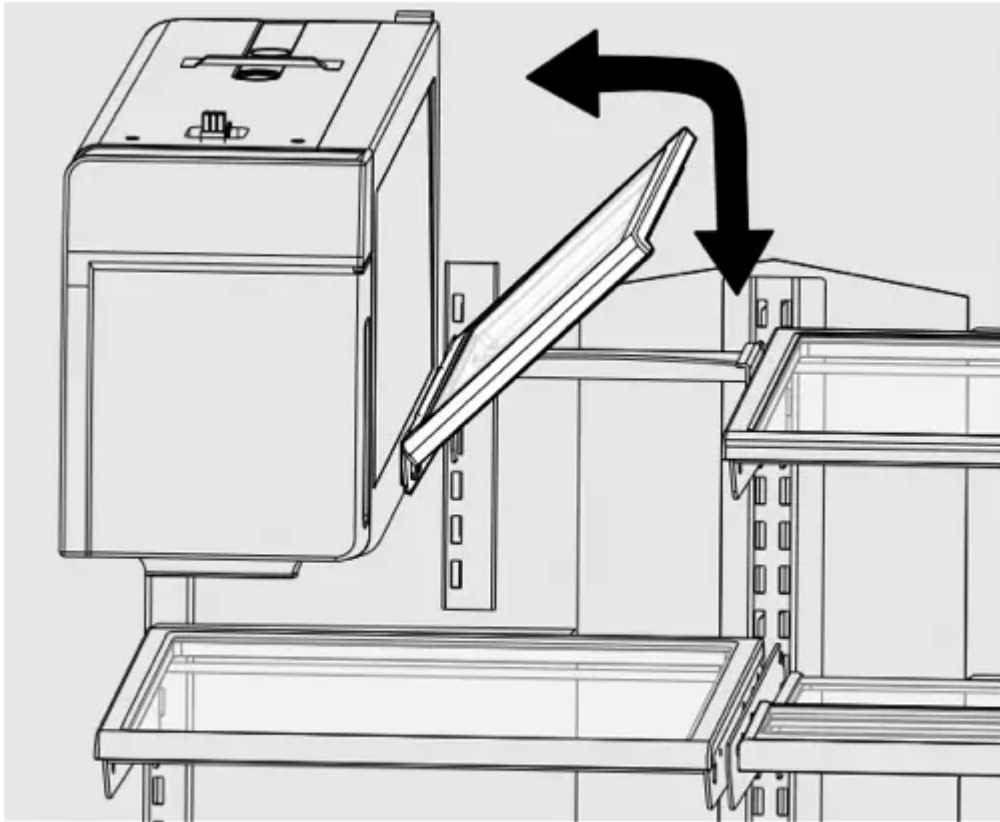

Flip Shelf

Crisper humidity control

Crisper drawers include a sliding control for adjusting the humidity inside the crisper. Leafy vegetables keep best when stored with the Humidity Control set on Higher Humidity. Fresh fruits keep best when stored with the Humidity Control set on Lower Humidity.

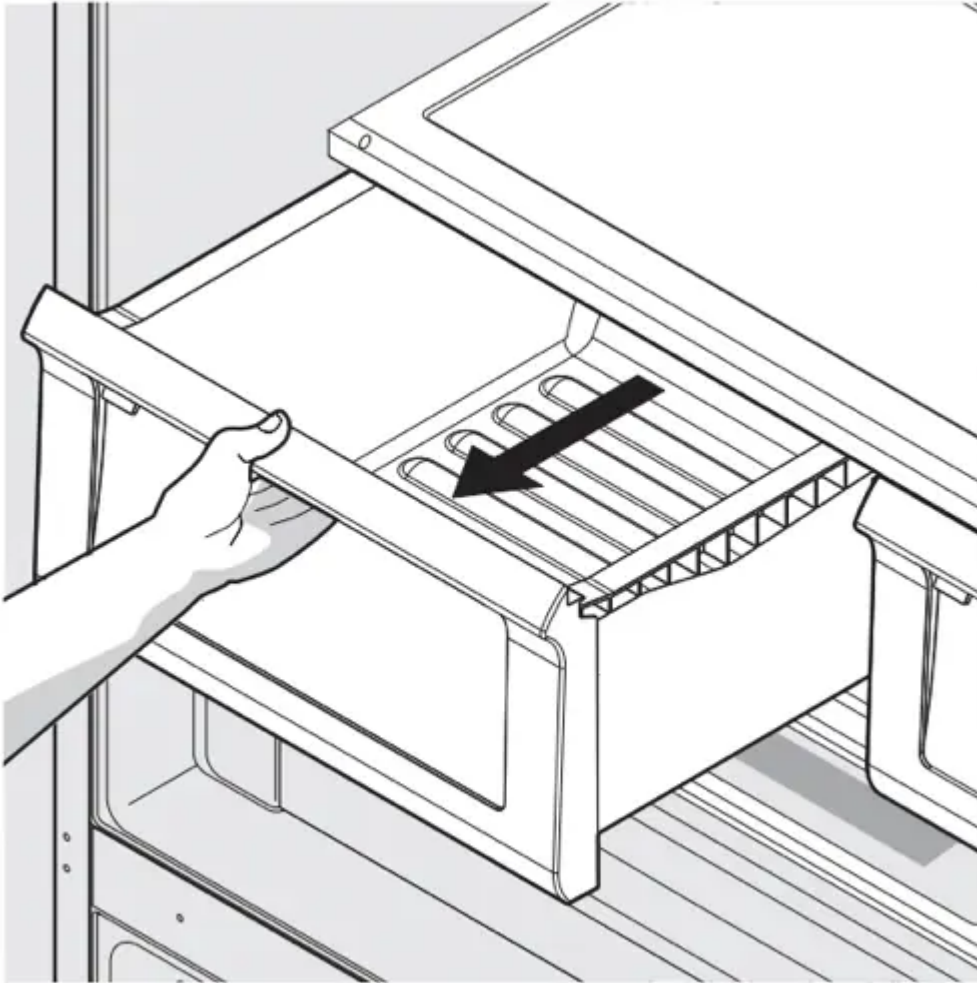

Opening Crisper Drawer

To remove the Crisper Drawer for cleaning:

1. Pull the drawer out until it stops.
2. Lift the front slightly and remove the drawer.

Doors

Storage bins (varies by model)

The doors to your fresh food compartment use a system of modular storage bins. All of these bins are removable for easy cleaning. Some of them have fixed positions, while others can be adjusted to your needs.

Door bins are ideal for storing jars, bottles, cans, and large drink containers. They also enable quick selection of frequently used items.

To change the position of an adjustable door bin:

1. Remove all food from door bin.
2. Grip the bin firmly with both hands and lift it upward.
3. Remove the bin.
4. Place the bin just above desired position.
5. Lower the bin onto supports until locked in place.

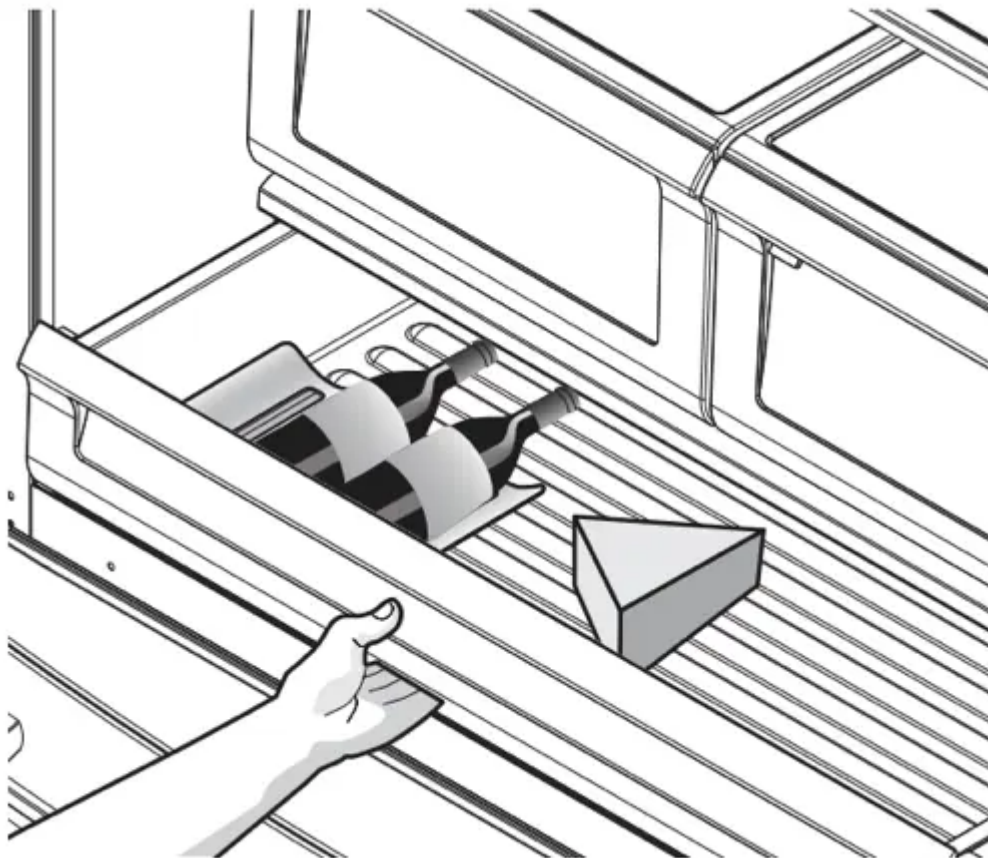

6. Place bin liner into bin.

Accessories (varies by model)

Removable Can Dispenser

The can dispenser holds six (12 ounce) cans.

Insert cans into top of bin and dispense from the bottom.

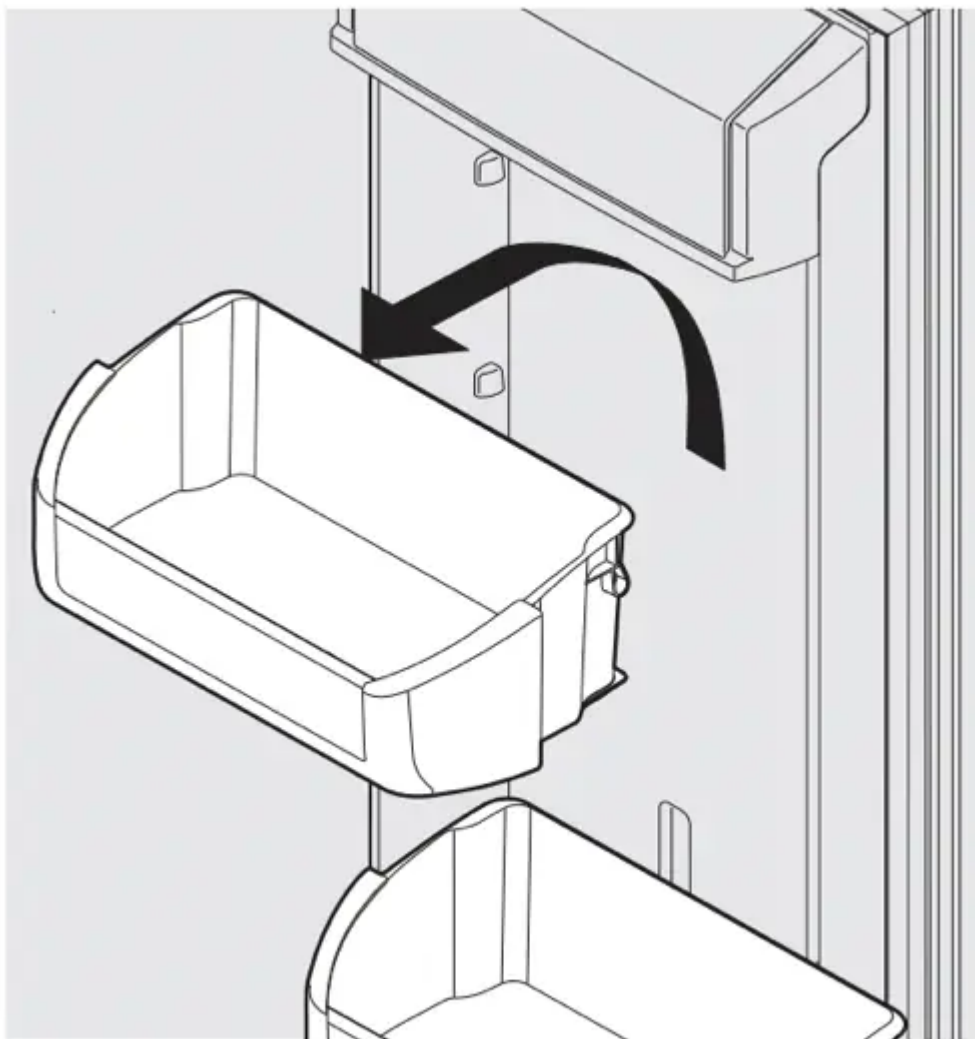

Adjustable Door Bin

Dairy compartment

Use the dairy compartment, at the top of the fresh food compartment door, for short-term storage of cheese, spreads, or butter. The dairy compartment is designed to be warmer than the open area and includes a lift-up cover and a dairy divider (select models).

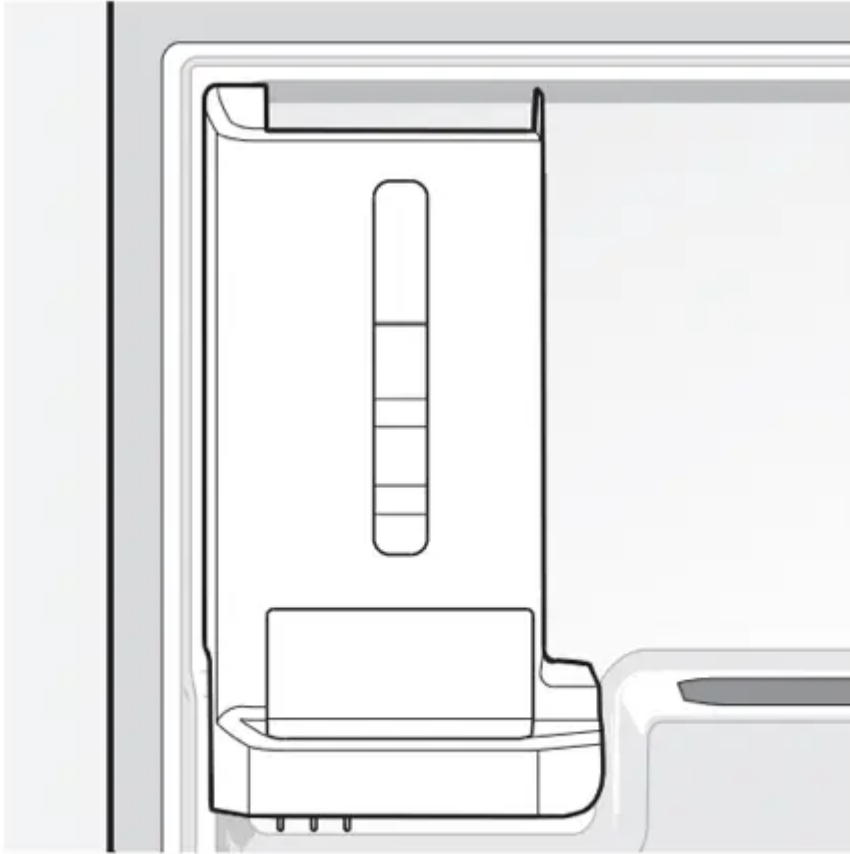

Can Dispenser

Freezer Features (varies by model)

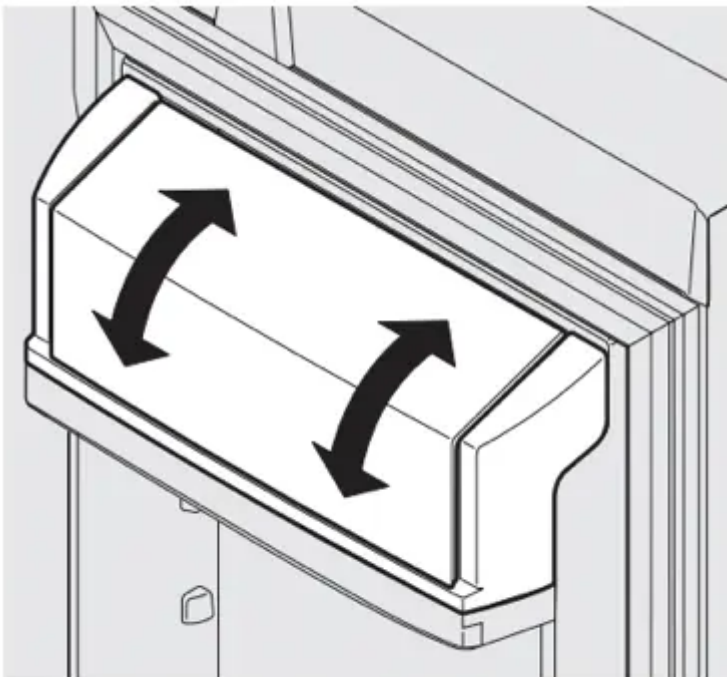

Dairy Compartment

To Remove Upper Freezer Basket

1. Find the side where the basket frame is aligned to the clip opening. The basket frame should be aligned to both front and rear clips on the same side (either left or right side).
2. If the basket frame is not aligned to the left or right side, push the basket sideways (to either side) until it is aligned.
3. By grabbing the basket wire frame close to the frontal clip, pull up to take the basket frame out.
4. Grab the basket frame close to the rear clip and pull up until it comes out of the clip.
5. Once one side of the basket is off the clips or retainers, slide the basket sideways until the other side of the frame is aligned with the clip openings on the opposite side of the freezer.
6. In the same way, pull up the basket frame from the frontal and rear clips until it is out of the clips.
7. Remove the basket.

Reverse the steps to reinstall the basket.

NOTE: If basket is not resting on stabilizer bar retainer clips, the drawer will not close properly.

Removing Freezer Basket Instructions

1. Locate the basket clips in the rear corners of the basket and pull them out to remove.
2. Open fresh food doors completely.
3. Lift the basket up and remove.

Replacing Freezer Basket Instructions

1. Place freezer basket back inside the freezer drawer.
2. Replace clips by sliding them back into the slots.

Dividers Removal

Lift up on the front of the upper divider and pull out.

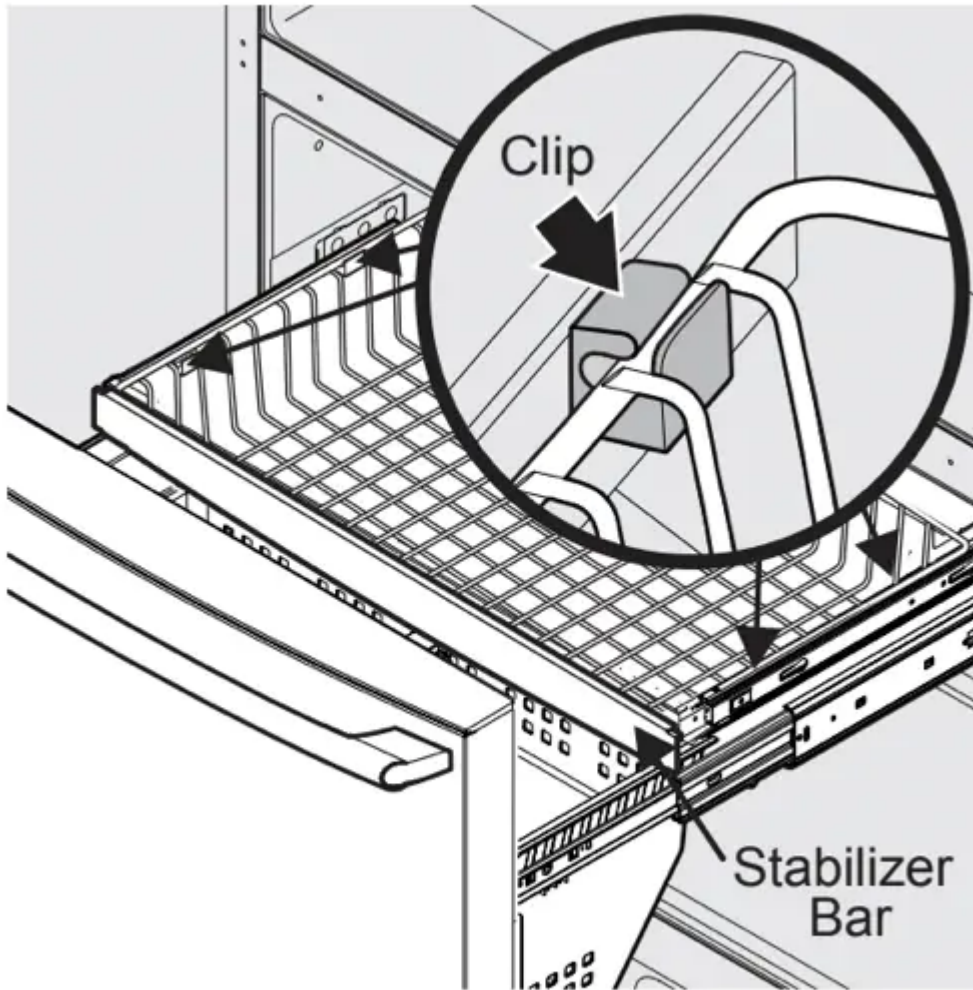

Freezer Baskets

Squeeze handle and lift up in the center of the divider to move it side-to-side. (The divider cannot be removed.)

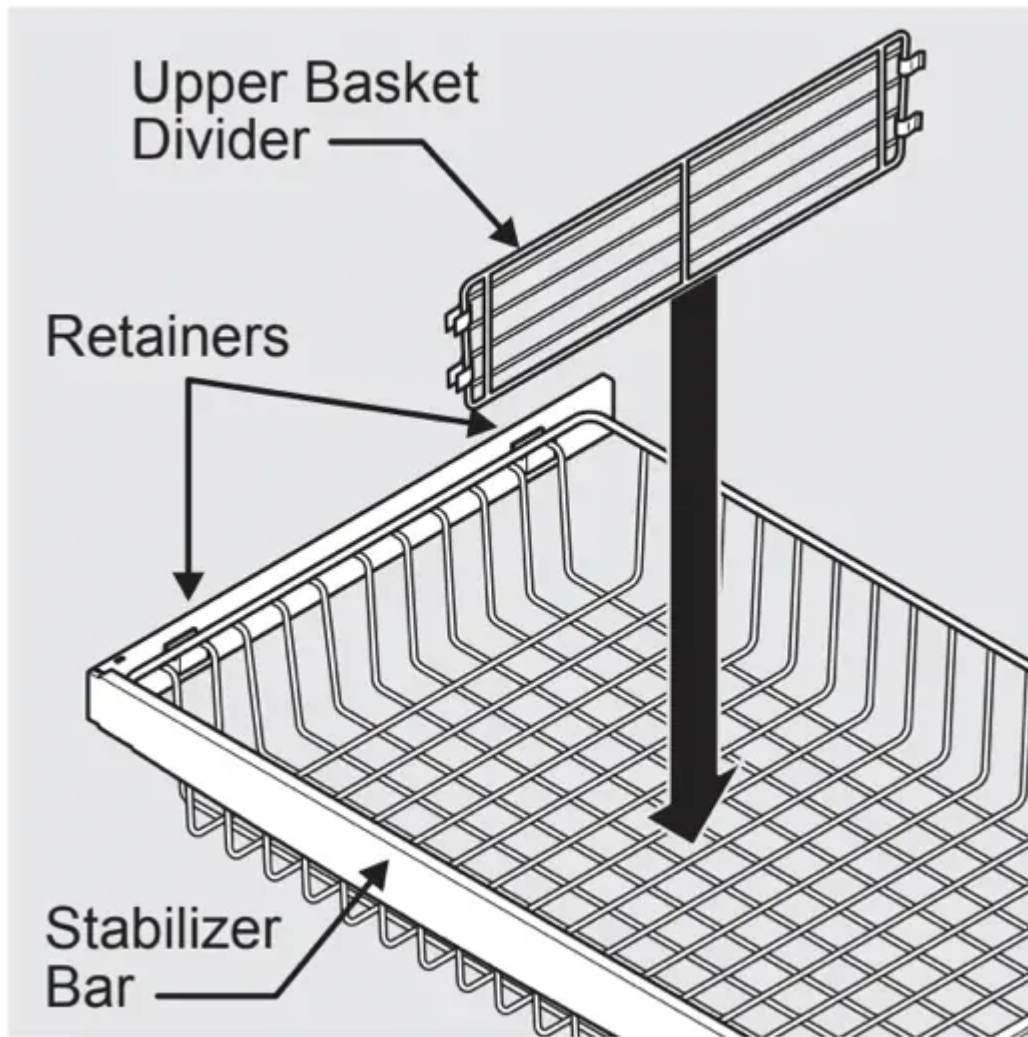

Upper Basket Divider

Tilt Wire Shelf

The freezer tilt wire shelf (located on the inside of the freezer drawer) is not designed to be removed.

STORING FOOD AND SAVING ENERGY

Ideas for storing foods

Fresh food storage

- Keep the fresh food compartment between 34°F and 40°F with an optimum temperature of 37°F.
- Avoid overcrowding the refrigerator shelves, which reduces air circulation and causes uneven cooling.
- Avoid placing food in front of air ports. (See Controls Section for illustration.)

Fruits and vegetables

- Store fruits and vegetables in crisper drawers, where trapped moisture helps preserve food quality for longer time periods.
- Wash items and remove excess water.
- Wrap any items that have strong odors or high moisture content.

Meat

- Wrap raw meat and poultry separately and securely to prevent leaks and contamination of other foods or surfaces.
- Use the deli drawer to store meat/poultry for short-term storage. Any meat to be kept longer than two days should be frozen.

Frozen food storage

- Keep the freezer compartment at 0°F or lower.
- A freezer operates most efficiently when it is at least 2/3 full.

Packaging foods for freezing

- To minimize food dehydration and quality deterioration, use aluminum foil, freezer wrap, freezer bags, or airtight containers. Force as much air out of the packages as possible and seal them tightly. Trapped air can cause food to dry out, change color, and develop an off-flavor (freezer burn).
- Wrap fresh meats and poultry with suitable freezer wrap prior to freezing.
- Do not refreeze meat that has completely thawed.

Loading the freezer

- Prior to grocery shopping, activate “quick freeze” so that on your return you can ensure your newly purchased food designated for the freezer will be preserved as quickly as possible.
- Activating “quick freeze” also will help your freezer more efficiently maintain the selected temperature after placing new purchases with pre-existing frozen foods.
- Avoid adding too much warm food to the freezer at one time. This overloads the freezer, slows the rate of freezing, and can raise the temperature of frozen foods.
- Leave a space between packages, so cold air can circulate freely, allowing food to freeze as quickly as possible.

Ideas for saving energy

Installation

- Locate the refrigerator in the coolest part of the room, out of direct sunlight, and away from heating ducts or registers.

- Do not place the refrigerator next to heat-producing appliances such as a range, oven, or dishwasher. If this is not possible, a section of cabinetry or an added layer of insulation between the two appliances will help the refrigerator operate more efficiently.
- Level the refrigerator so that the doors close tightly.

Temperature settings

- Refer to the “Controls” section for procedures on temperature settings.

Food storage

- Avoid overcrowding the refrigerator or blocking cold air vents. Doing so causes the refrigerator to run longer and use more energy.
- Cover foods and wipe containers dry before placing them in the refrigerator. This cuts down on moisture build-up inside the unit.
- Organize the refrigerator to reduce door openings. Remove as many items as needed at one time and close the door as soon as possible.
- Do not place a hot container directly on a cold shelf. Remember, such an extreme temperature change may damage the glass.

NORMAL OPERATING SOUNDS AND SIGHTS

Understanding the sounds you may hear

Your new, high-efficiency refrigerator may introduce unfamiliar sounds. These sounds normally indicate your refrigerator is operating correctly. Some surfaces on floors, walls, and kitchen cabinets may make these sounds more noticeable.

The following is a list of major components in your refrigerator and the sounds they can cause:

A. Evaporator Refrigerant through the evaporator may create a boiling or gurgling sound.

B. Evaporator fan You may hear air being forced through the refrigerator by the evaporator fan.

C. Defrost heater During defrost cycles, water dripping onto the defrost heater may cause a hissing or sizzling sound. After defrosting, a popping sound may occur.

D. Automatic ice maker When ice has been produced, you will hear ice cubes falling into the ice bin. Ice maker fan, water valve activation, and refrigerant gas fluid may create sounds from its operation.

E. Electronic control & automatic defrost control These parts can produce a snapping or clicking sound when turning the cooling system on and off.

F. Condenser fan You may hear air being forced through the condenser.

G. Compressor Modern, high-efficiency compressors run much faster than older models. The compressor may have a high-pitched hum or pulsating sound.

H. Water valve Makes a buzzing sound each time it opens to fill the ice maker.

I. Drain pan (not removable) You may hear water dripping into the drain pan during the defrost cycle.

J. Condenser May create minimal sounds from forced air.

K. Motorized damper May produce a light humming during operation.

L. Ice dispensing paddle When dispensing ice, you will hear a snapping, clicking, or popping sound.

NOTE: Energy efficient foam in your refrigerator is not a sound insulator.

NOTE: During automatic defrost cycle, a red glow in the back wall vents of your freezer compartment is normal.

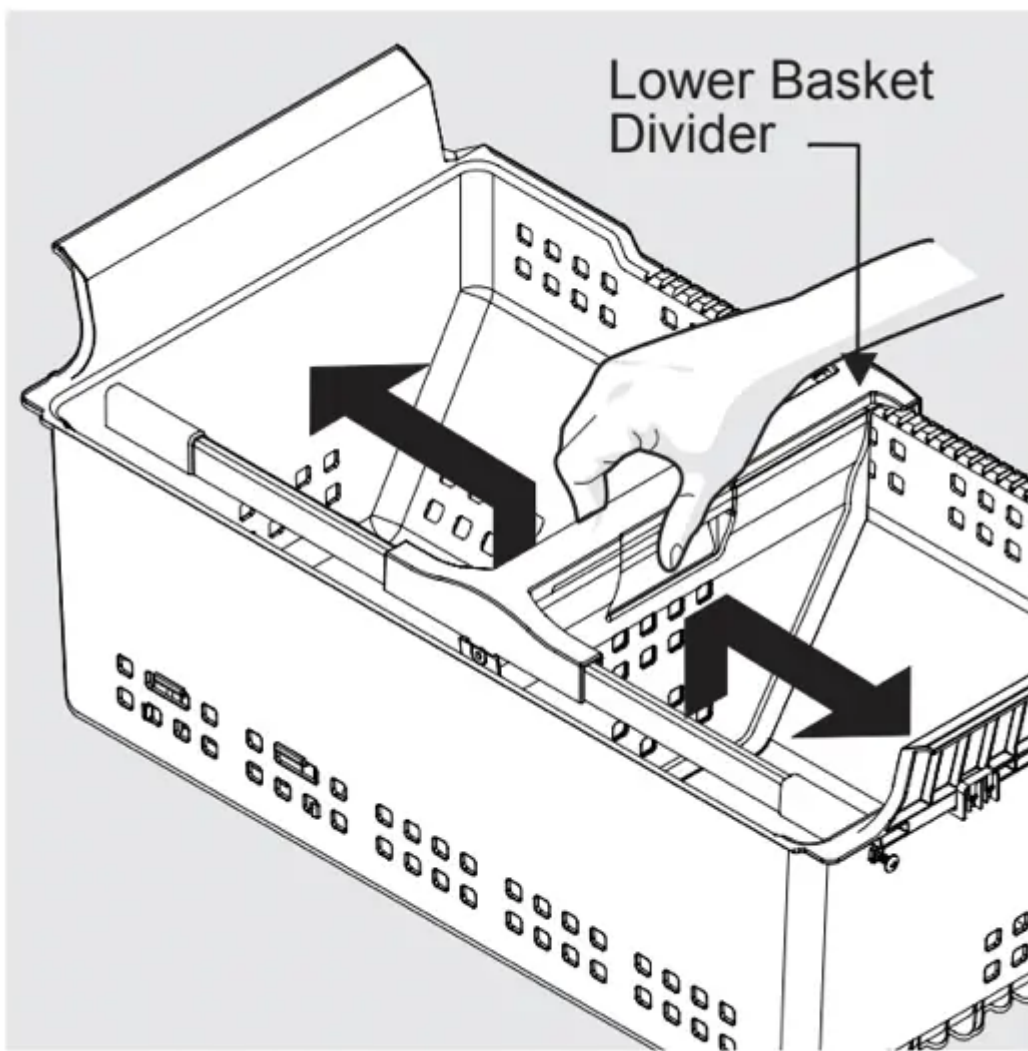

Plastic Lower Basket Divider

CHANGING THE FILTER

Air filter (Frigidaire Professional)

The air filter is located under the utility bin.

Replacing your PureAir Ultra IITM air filter

To ensure optimal filtering of refrigerator odors, you should change the air filter every six months (the filter status light on the Touch Panel prompts you to replace the filter after six months).

1. Insert fingers in circled area.
2. Push clips in to release front cover.
3. Remove front cover by pulling towards you and lifting up.
4. Replace air filter by sliding into slots.
5. Installation of front cover is reverse of removal.
6. To reset Air Filter status, refer to instructions under “Controls Section”.

Locating the Filters

Your refrigerator is equipped with water filtering system. The water filter system filters all dispensed drinking water, as well as the water used to produce ice.

Water Filter

The water filter is located at the top right side of the fresh food compartment.

Replacing the Water Filter

In general, you should change the water filter every six months to ensure the highest possible water quality. Water Filter Status on the user interface prompts you to replace the filter after a standard amount of water (125 gallons/473 liters for PureSource Ultra IITM) has flowed through the system. If your refrigerator has not been used for a period of time (during moving for example), change the filter before reinstalling the refrigerator.

NOTE: When ordering your replacement filter, please reorder the same filter type that is currently in your refrigerator.

More about your Advanced Water Filter

The **PureSource Ultra IITM** ice and water filter system is tested and certified to NSF/ANSI Standards 43, 53 and 401 for the reduction of claims specified on the performance data sheet.

Do not use with water that is microbiologically unsafe or of unknown quality without adequate disinfection before or after the system. Systems certified for cyst reduction may be used on disinfected waters that may contain filterable cysts.

Test & certification results:

- Rated Capacity - 125 gallons/473 liters for **PureSource Ultra IITM** ice and water filter
- Rated service flow - .65 gallons per minute
- Operating Temp: Min. 33°F, Max. 100°F
- Maximum Rated Pressure - 100 pounds per square inch
- Recommended Minimum Operating Pressure: 30 pounds per square inch

To replace your PureSource Ultra IITM water filter:

It is not necessary to turn the water supply off to change the filter. Be ready to wipe up any small amounts of water released during the filter replacement.

1. Turn Off the ice maker power switch.
2. Remove the old filter by rotating it counter-clockwise (to the left) 90 degrees to release it.
3. Slide the old filter cartridge straight out of the housing and discard it.
4. Unpackage the new filter cartridge. Slide it into the filter housing as far as it will go with the grip end horizontal.
5. Push lightly inward on the filter while rotating it clockwise (to the right). The filter will then pull itself inward as it is rotated. Rotate the filter 90 degrees until it stops and the grip end is vertical. You may be able to feel a very light click as the filter locks into place.
6. Press a drinking glass against the water dispenser while checking for any leaks at the filter housing. Any spurts and sputters that occur as the system purges air out of the dispenser system are normal.
7. Continue dispensing water for 3-4 minutes or until 1.5 gallons of water has flowed through the system. You will likely need to empty and refill your glass several times.
8. Turn On the ice maker.
9. Press and hold the Water Filter reset button on the control panel for three seconds. When the display changes from Red to Green, the status has been reset.

CARE & CLEANING

Protecting your investment

Keeping your refrigerator clean maintains its appearance and prevents odor build-up. Wipe up any spills immediately and clean the freezer and fresh food compartments at least twice a year.



NOTE: Do not use abrasive cleaners such as window sprays, scouring cleansers, flammable fluids, cleaning waxes, concentrated detergents, bleaches, or cleansers containing petroleum products on plastic parts, interior doors, gaskets, or cabinet liners. Do not use paper towels, scouring pads, or other abrasive cleaning materials.

- Never use metallic scouring pads, brushes, abrasive cleaners, or strong alkaline solutions on any surface.
- Never use CHLORIDE or cleaners with bleach to clean stainless steel.
- Do not wash any removable parts in a dishwasher.
- Always unplug the electrical power cord from the wall outlet before cleaning.

NOTE: If you set your temperature controls to turn off cooling, power to lights and other electrical components will continue until you unplug the power cord from the wall outlet.

- Remove adhesive labels by hand. Do not use razor blades or other sharp instruments which can scratch the appliance surface.
- Do not remove the serial plate. Removal of your serial plate voids your warranty.
- Before moving your refrigerator, raise the anti-tip brackets so the rollers will work correctly. This will prevent the floor from being damaged.

Refer to the guide on the next page for details on caring and cleaning specific areas of your refrigerator.

CAUTION!

- Pull the refrigerator straight out to move it. Shifting it from side to side may damage flooring. Be careful not to move the refrigerator beyond the plumbing connections.
- Damp objects stick to cold metal surfaces. Do not touch refrigerated surfaces with wet or damp hands.

IMPORTANT: If you store or move your refrigerator in freezing temperatures, be sure to completely drain the water supply system. Failure to do so could result in water leaks when the refrigerator is put back into service. Contact a service representative to perform this operation.

Vacation and moving tips

Short Vacations

- Leave refrigerator operating during vacations of three weeks or less.
- Use all perishable items from refrigerator compartment.
- Turn automatic ice maker off and empty ice bucket, even if you will only be gone a few days.

Long Vacations

- Remove all food and ice if you will be gone one month or more.

- Turn the cooling system off (see “Controls” section for location of On/Off button) and disconnect power cord.
- Turn water supply valve to closed position.
- Clean interior thoroughly.
- Leave both doors open to prevent odors and mold build-up. Block doors open if necessary.

Moving

- Remove all food and ice.
- If using a handcart, load from the side.
- Adjust rollers all the way up to protect them during sliding or moving.
- Pad cabinet to avoid scratching surface.

Care & Cleaning Tips

Interior & Door Liners

- Soap and water
- Baking soda and water
 - Use two tablespoons of baking soda in one quart of warm water. **Be sure to wring excess water out of sponge or cloth before cleaning around controls, light bulb or any electrical part.**

Door Gaskets

- Soap and water
 - Wipe gaskets with a clean soft cloth.

Drawers & Bins

- Soap and water
 - Use a soft cloth to clean drawer runners and tracks.

Glass Shelves

- Soap and water
- Glass cleaner
- Mild liquid sprays
 - Allow glass to warm to room temperature before immersing in warm water.

Toe Grille

- Soap and water
- Mild liquid sprays

- Vacuum attachment
 - Vacuum dust from front of toe grille. Remove toe grille (see Installation Instructions). Vacuum backside, wipe with sudsy cloth or sponge. Rinse and dry.

Exterior & Handles

- Soap and water
- Non Abrasive Glass Cleaner
 - Do not use commercial household cleaners containing ammonia, bleach or alcohol to clean handles. Use a soft cloth to clean smooth handles. **DO NOT use a dry cloth to clean smooth doors.**

Exterior & Handles (Stainless Steel Models Only)

- Soap and water
- Stainless Steel Cleaners
 - **Never use CHLORIDE or cleaners with bleach to clean stainless steel.** Clean stainless steel front and handles with non-abrasive soapy water and a dishcloth. Rinse with clean water and a soft cloth. Use a non-abrasive stainless steel cleaner. These cleaners can be purchased at most home improvement or major department stores. Always follow manufacturer's instructions. Do not use household cleaners containing ammonia or bleach.
 - NOTE:** Always clean, wipe and dry with the grain to prevent scratching. Wash the rest of the cabinet with warm water and mild liquid detergent. Rinse well, and wipe dry with a clean soft cloth.

BEFORE YOU CALL

Automatic Ice Maker

Ice maker is not making any ice.

- Ice maker is turned off.
 - Turn on ice maker. For the fresh food ice maker, press ice maker on-off button once. For the freezer ice maker, lower the arm to turn the ice maker on, or raise it and snap it in its upper position to turn the ice maker off.
- Refrigerator is not connected to water line or water valve is not open.
 - Connect the unit to the household water supply and ensure the water valve is open.

- The water supply line is kinked.
 - Ensure that the supply line does not kink when the refrigerator is pushed into place against the wall.
- The water filter is not seated properly.
 - Remove and re-install the water filter. Be sure to seat it fully into the locked position.
- The water filter may be clogged with foreign material.
 - If water dispenses slowly or not at all, or if the filter is six months old or older, it should be replaced.
- Freezer ice maker wire signal arm is being held up by an item not allowing it to go in the on or down position.
 - Move any item or frozen ice cubes that may block the signal arm from being in the on or down position. Additionally, the ice bin itself may be out of position so that it prevents the signal arm from dropping all the way down. Be sure the bin is pushed all the way to the rear of the shelf. See Automatic Ice Maker- Freezer section in manual.

Ice maker is not making enough ice.

- Ice maker is producing less ice than you expect.
 - The ice maker will produce approximately 2.0 to 2.5 pounds of ice every 24 hours depending on usage conditions.
- The water filter may be clogged with foreign material.
 - If water dispenses slower than normal, or if the filter is six months old or older, it should be replaced.
- The water supply line is kinked.
 - Ensure that the supply line does not kink when the refrigerator is pushed into place against the wall.
- Saddle valve on cold water pipe is clogged or restricted by foreign material.
 - Turn off household water line valve. Remove valve. Clean valve. Replace valve if necessary.
- Heavy traffic, opening or closing of the doors excessively.
 - Press Fast Freeze to temporarily increase ice production rate. (Freezer ice maker only.)



- Freezer control is set too warm (freezer ice maker).
 - Set freezer control to colder setting to improve performance of the ice maker (freezer ice maker). Allow 24 hours for temperature to stabilize.
- Water pressure is extremely low. Cut-off and cut-on pressures are too low (well systems only).
 - Have someone turn up the cut-off and cut-on pressure on the water pump system (well systems only).
- Reverse osmosis system is in regenerative phase.
 - It is normal for a reverse osmosis system to be below 20 psi during the regenerative phase.

Freezer ice maker will not stop making ice (select models).

- Ice maker wire signal arm is being held down by a package in the freezer that has fallen against ice maker.
 - Move any item or frozen ice cubes that may block the signal arm from being in the off or upward position. See Automatic Ice Maker-Freezer section in manual.

Ice cubes are freezing together.

- Ice cubes are not being used frequently enough or interruption of power for prolonged time.
 - Remove ice container and discard ice. The ice maker will produce fresh supply. Ice should be used at least twice to keep the cubes separated.
- Ice cubes are hollow (shells of ice with water inside). The hollow cubes break open in the bin and leak their water onto existing ice, which causes it to freeze together.
 - This generally occurs when the ice maker does not get enough water. This is usually the result of a clogged water filter or restricted water supply. Replace the water filter and if the condition still occurs check for a clogged Saddle Valve, water valve not turned on all the way or kinked water supply line.

Dispenser (Ice & Water)

Dispenser will not dispense ice.

- There is no ice in the bin to be dispensed.
 - See the “Ice maker is not making any ice” section above.
- The refrigerator doors are not completely closed.
 - Be sure the refrigerator doors are completely closed.



- Dispenser paddle has been pressed too long and the dispenser motor has overheated.
 - The motor overload protector will reset in about three minutes and then ice can be dispensed.

Ice dispenser is jammed.

- Ice has melted and frozen around auger due to infrequent use, temperature fluctuations, and/or power outages.
 - Remove ice container, thaw, and empty the contents. Clean container, wipe dry, and replace in proper position. When new ice is made, dispenser should operate.
- Ice cubes are jammed between ice maker and back of ice container.
 - Remove ice cubes that are jamming the dispenser.

Dispenser will not dispense water.

- Water filter not seated properly.
 - Remove and reinstall the water filter. For Puresource Ultra II, be sure to rotate it to the right until it stops and the grip end is vertical.
- Water filter is clogged.
 - Replace filter cartridge. Be sure to rotate it to the right until it stops and the grip end is vertical.
- Household water line valve is not open.
 - Open household water line valve. See CONCERN column AUTOMATIC ICE MAKER.

Water not cold enough.

- The water dispensing system is not designed to chill water.
 - Add ice to cup or container before dispensing water.

Water has an odd taste and/or odor.

- Water has not been dispensed for an extended period of time.
 - Draw and discard 10-12 glasses of water to freshen the supply.
- Unit not properly connected to cold water line.
 - Connect unit to cold water line that supplies water to the kitchen faucet.



Opening/Closing Of Doors/Drawers

Door(s) will not close.

- Door was closed too hard, causing other door to open slightly.
 - Close both doors gently.
- Refrigerator is not level. It rocks on the floor when moved slightly.
 - Ensure floor is level and solid, and can adequately support the refrigerator. Contact a carpenter to correct a sagging or sloping floor.
- Refrigerator is touching a wall or cabinet.
 - Ensure floor is level and solid, and can adequately support the refrigerator. Contact a carpenter to correct a sagging or sloping floor.

Drawers are difficult to move.

- Food is touching shelf on top of drawer.
 - Remove top layer of items in drawer.
- Track that drawers slide on is dirty.
 - Ensure drawer is properly installed on track.
 - Clean drawer, rollers, and track. See Care & Cleaning.

Running of Refrigerator

Compressor does not run.

- Freezer control is set to "OF".
 - Set freezer control.
- Refrigerator is in defrost cycle.
 - This is normal for a fully automatic defrost refrigerator. The defrost cycle occurs periodically, lasting about 30 minutes.
- Plug at electrical outlet is disconnected.
 - Ensure plug is tightly pushed into outlet.
- House fuse blown or tripped circuit breaker.
 - Check/replace fuse with a 15 amp time-delay fuse. Reset circuit breaker.
- Power outage.
 - Check house lights. Call local electric company.

Refrigerator seems to run too much or too long.

- Your variable speed compressor is designed to run 100% of the time except during the defrost cycle. At times it will run faster, such as after a defrost cycle.
 - It is normal for the compressor to run continuously except during defrost mode.

Digital Temperature Setting Display

Digital temperature displays an error.

- Electronic control system has detected a performance problem.
 - Call your Electrolux service representative, who can interpret any messages or number codes flashing on the digital displays.

Water/Moisture/Frost Inside Refrigerator

Moisture collects on inside of refrigerator walls.

- Weather is hot and humid.
 - The rate of frost buildup and internal sweating increases.
- Flipper mullion
 - Adjust flipper mullion. (See “To adjust the flipper mullion” in the Installation section.)

Water collects on bottom side of drawer cover.

- Vegetables contain and give off moisture.
 - It is not unusual to have moisture on the bottom side of the cover. Move humidity control (some models) to lower setting.

Water collects in bottom of drawer.

- Washed vegetables and fruit drain while in the drawer.
 - Water collecting in bottom of drawer is normal. Dry items before putting them in the drawer or store produce in tightly sealed bags to help reduce condensation inside of the drawer.

Water/Moisture/Frost Outside Refrigerator

Moisture collects on outside of refrigerator or between doors.

- Weather is humid.
 - This is normal in humid weather. When humidity is lower, the moisture should disappear.

Food in Fresh Food Compartment

Food is freezing.

- Temperature setting is too low.
 - Move the setting to a higher degree.
- Temperature sensor is covered by food (right side of fresh food area).
 - Allow space for air flow to the sensor.
- Food is covering the air ports.
 - Allow space between the air ports and the food.

Warning

This content is compiled from multiple sources and is provided for reference purposes only. It may not be complete or fully applicable to all situations. If you are unable to resolve your issue, please contact the product manufacturer or an authorized service provider for official support.