

About the operation of your freezer

Starting the Freezer - Electromechanical (on some models)

1. Clean the inside of the freezer with a mild solution of baking soda and water (see Care and Cleaning).
2. Connect cord to power outlet.
3. Make sure the temperature control is set at 4.
4. Allow freezer to operate for at least four hours before placing food inside.

Temperature Control

For safe food storage, allow 4 hours for the freezer to cool down completely. The freezer will run continuously for the first several hours. Foods that are already frozen may be placed in the freezer after the first few hours of operation. Unfrozen food should NOT be placed in the freezer until it has operated for 4 hours. Allow several hours after each one-step adjustment for the freezer temperature to stabilize.

When loading the freezer, freeze only 3 pounds of fresh food per cubic foot of space at a time. Distribute packages evenly throughout the freezer. It is not necessary to turn the control knob to a colder setting while freezing food.

Turning the control to OFF stops the cooling process but does not shut off power to the freezer.

Electromechanical Temperature Control

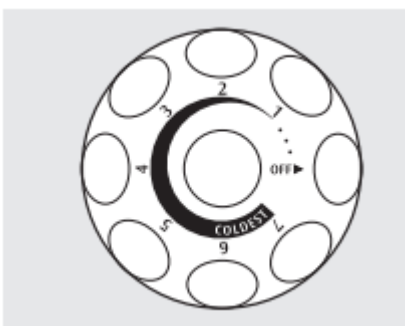

The electromechanical temperature control is preset to give satisfactory food storage temperatures. It is adjustable to provide a range of temperatures. Allow several hours for the temperature to stabilize between adjustments.

The electromechanical temperature control is inside the freezer.

Starting the Freezer - Electronic Temperature Control (on some models)

1. Clean the inside of the freezer with a mild solution of baking soda and water (see Care and Cleaning).
2. Connect cord to power outlet.
3. Press “-” or “+” to reach desired temperature
4. Press Set at when desired temperature is displayed.
5. Allow freezer to operate for at least four hours before placing food inside.

Temperature Control

For safe food storage, allow 4 hours for the freezer to cool down completely. The freezer will run continuously for the first several hours. Foods that are already frozen may be placed in the freezer after the first few hours of operation. Unfrozen food should NOT be placed in the freezer until it has operated for 4 hours. Allow several hours after each one-step adjustment for the freezer temperature to stabilize.

When loading the freezer, freeze only 3 pounds of fresh food per cubic foot of space at a time. Distribute packages evenly throughout the freezer. It is not necessary to turn the control knob to a colder setting while freezing food.

Turning the control to OFF stops the cooling process but does not shut off power to the freezer.

Sabbath Mode

The Sabbath mode is a feature that disables portions of the appliance and its controls in accordance with observance of the weekly Sabbath and religious holidays within the Orthodox Jewish community.

To turn Sabbath mode on, press and hold the “Options” button and “+” button for 5 seconds, after which “Sb” will be displayed on the control panel indicating that the unit is in Sabbath mode. To exit Sabbath mode, press and hold the “Options” button and “+” button for 5 seconds, after which the display will return to displaying the set point of the unit.

In the Sabbath mode, the High Temp alarm is active for health reasons. If a high temperature alarm is activated during this time, for example due to a door left ajar, the alarm will sound for about 10 minutes. The alarm will then silence on its own and a “high temp” icon will be displayed on the control panel. The high temp icon will continue to display even if the door is closed until Sabbath mode is exited and the icon reset.

For further assistance, guidelines of proper usage and a complete list of models with the Sabbath feature.

NOTE: While in Sabbath mode, neither the lights nor the control panel will work until Sabbath mode has been deactivated.

The unit stays in Sabbath mode after a power failure recovery. It must be deactivated with the buttons on the control panel.

About the operation of your freezer

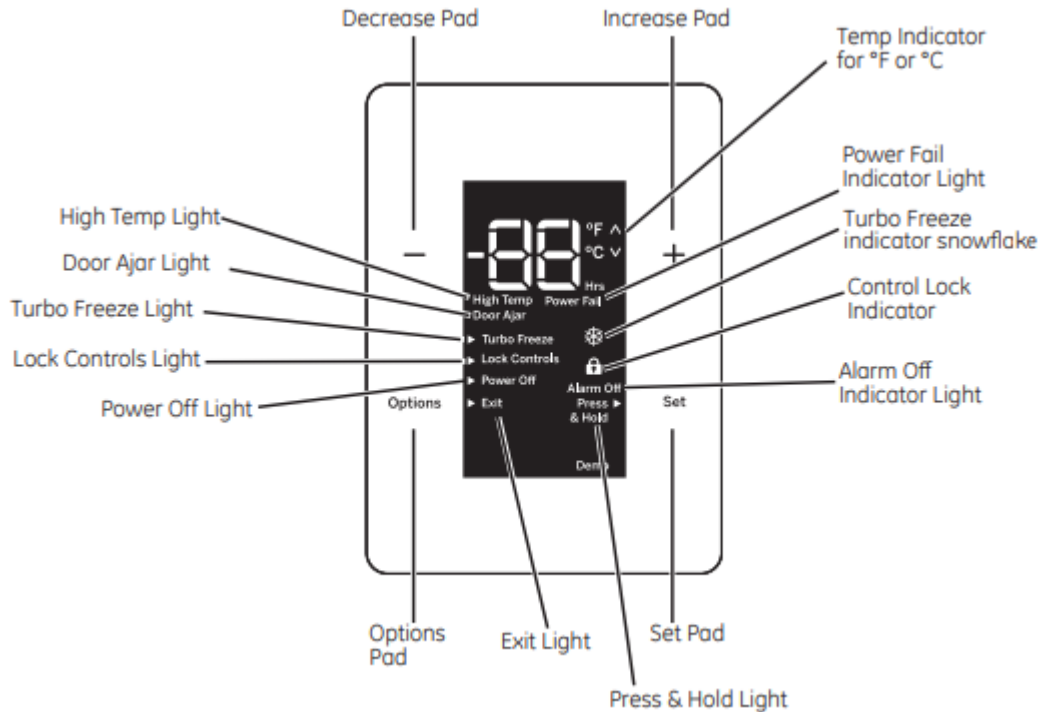

Electronic Temperature Control

This electronic temperature control is located on the front of the freezer door. The temperature is factory-preset to provide satisfactory food storage temperatures. To adjust the temperature setting, press - to decrease temperatures and + to increase temperatures. Allow several hours for the temperature to stabilize between adjustments.

Temp Alarm

This electronic control has a temperature alarm feature. An alarm will sound if the freezer temperature reaches unsafe levels. To silence the alarm, push Set or any key on the control panel.

Turbo Freeze

To enable Turbo Freeze, press Options until the indicator for "Turbo Freeze" is highlighted and then press Set. The unit will be in "Turbo Freeze" mode for 72 hours and the snowflake will be highlighted. After the 72 hours is completed, "Turbo Freeze" turns off automatically. The snowflake will turn off to show that "Turbo Freeze" is off. To exit "Turbo Freeze" before the 72 hour automatic shutoff, press Options until the indicator for "Turbo Freeze" is highlighted and press Set. The snowflake will go off showing that "Turbo Freeze" is not active.

Control Lock

To lock the controls, press Options until the display reads “Lock Controls” and then press Set. The locked indicator light will be displayed. To unlock, press and hold Set for 3 seconds. The indicator light will go off and the control panel will be unlocked.

Power Off

To turn the freezer off, press Options the display reads “Power Off”. Press and hold Set for 3 seconds. When the freezer is off, the only words illuminated will be “Power Off” and “Press & Hold” (referring to the Set pad). To power back on, press and hold Set for 3 seconds. The unit will then be in standby mode.

Power Fail

If your unit has lost power, the control panel will display “Power Fail” and the number of hours that your unit has been without power up to a maximum of 50 hrs once the power has been restored. The alarm will sound until the condition is acknowledged by pressing Set or any other button on the control panel.

Door Ajar

If your door has been left open for more than 5 minutes, the control panel will display “Door Ajar” and will sound an alarm until the door has been closed or any button is pressed on the control panel. If a button on the control panel has been pressed but the door has not been closed, “Door Ajar” will continue to be displayed on the control panel until the door has been closed.

High Temp Light

The high temperature light will illuminate until the freezer reaches 23° F (-5° C) (safe zone) and the cabinet reaches the set temperature.

C or F Setting

To change between C° or F°, press and hold the - and + pads at the same time for 5 seconds.

Power-On Light (on some models)

The Power-On Light indicates that the freezer is properly connected to the electrical power.

The light glows even when the temperature control is turned off.

Key-Ejecting Lock (on some models)

The key for the spring-loaded lock is automatically ejected—key will not remain in lock in either the open or closed position.

Keep the key out of reach of children and away from the freezer

Freezer Shelves (on some models)

The spacers (on some models) are used to secure the shelves during shipping. Remove and discard the spacers.

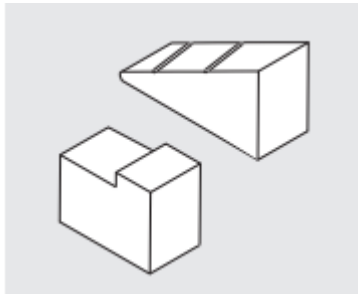

Slide-Out Basket (on some models)

A slide-out basket provides separate storage space for items that are difficult to store on shelves. It is located at the bottom of the freezer. To remove this basket, pull out and lift up.

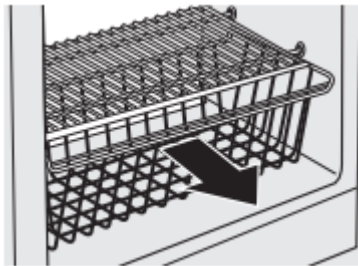

Interior Light

The interior light comes on when the freezer door is opened. To replace the bulb, set the temperature control to OFF and unplug the electrical cord. Replace the bulb by unscrewing it from the fixture. Replace with the same size and wattage.

To replace LED bulbs use a flat head screwdriver to remove the cover. Remove light from connector and replace it with a new one. Set light back in place and reinstall cover.

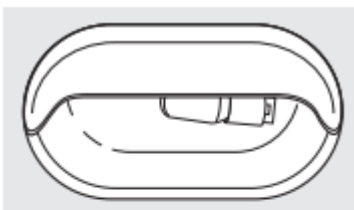

Or

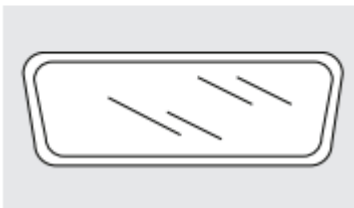

If new LED bulbs are needed, call GE Parts and Accessories at 1.800.626.2002. In Canada, call 1.800.661.1616.

CAUTION Light bulbs may be hot. Burned out bulbs may break when being replaced.

About the operation of your freezer

Adjustable Shelves

The adjustable shelves can be moved to different levels within the freezer. To move the shelf, grasp the shelf and push to either the right or the left to disengage the ends of the shelf from placement holes in the freezer. Tilt the shelf to release the other side. To install the shelf, reverse these directions.

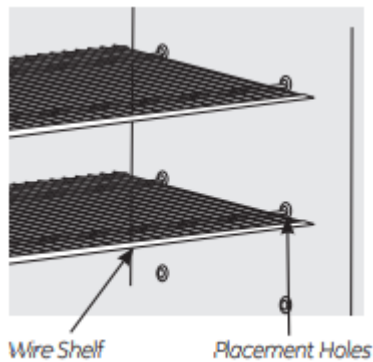

Adjustable Door Bins (on some models)

The adjustable door bins provide flexible storage space. The number of bins varies by model.

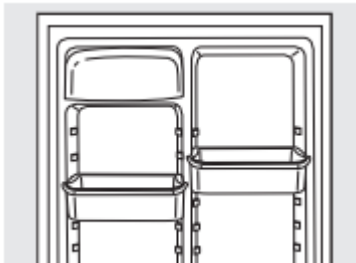

Soft Freeze Zone (on some models)

The Soft Freeze Zone is specifically for foods such as ice cream. It is designed to maintain a higher temperature than the rest of the freezer.

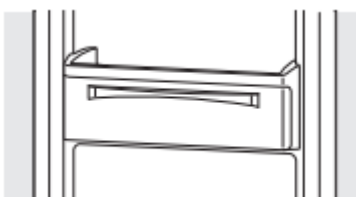

Wire Shelf Bookend (on some models)

Use these handy bookends to keep various boxed items stored neatly in your freezer. To adjust the location, simply unsnap the bookend from the wire shelf and snap into the next desired location.

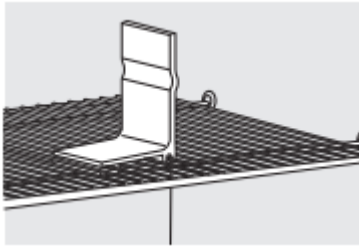

Defrosting instructions

(For Manual Defrost models)

In most climates, defrosting will be necessary only about twice a year.

To have your freezer operate most efficiently do not permit more than 1/2 " (13 mm) of frost to accumulate on the shelves.

To remove frost, scrape with a plastic or wood spatula or scraper.

Do not use an ice pick or sharp-edged instrument as it may damage or scratch the freezer.

Do not use any electrical device in defrosting your freezer.

For Complete Defrosting

1. Turn the temperature control to OFF and unplug the freezer.

2 Remove all food and place it in corrugated boxes, insulated bags, picnic coolers, etc. Use towels and newspapers for insulation as needed.

3 With the door open, use pans of hot water to speed loosening of frost. Remove large pieces before they melt.

On models without a defrost drain, place towels or newspapers on the freezer bottom to catch the frost. The frost will loosen and fall. Remove towels and/or newspapers.

4 Some Upright models have a hose adapter and a drain hose behind the base grille which carry the defrost water out from the freezer. Remove the base grille; then remove the drain plug and let the defrost water drain into a pan.

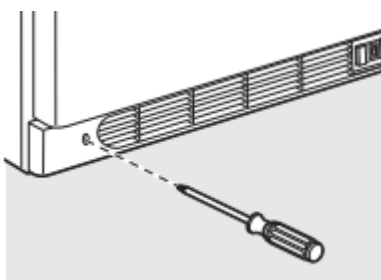

To remove the base grille (on some models), remove the two Phillips-head screws and pull the grille away from the freezer.

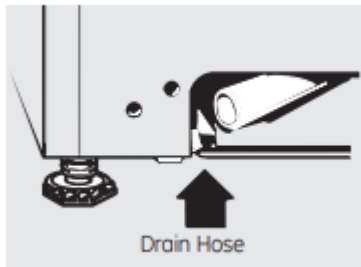

5 Sponge excess water from the bottom of the freezer as it collects to prevent overflowing.

6 After defrosting, clean the inside of the freezer (see Care and Cleaning).

7 Be sure to replace the drain plug and return the drain tube to its position. Replace the base grille.

8 Plug in the freezer. Return the temperature control to its previous position and return food to the freezer.

Care and cleaning of the freezer

Cleaning Your Freezer

Outside. Protect the paint finish. The finish on the outside of the freezer is a high quality, baked-on paint finish. With proper care, it will stay new-looking and rust-free for years. Apply a coat of appliance polish wax when the freezer is new and then at least twice a year. Appliance polish wax also works well to remove tape residue from freezer surfaces.

Keep the finish clean. Wipe with a clean cloth lightly dampened with appliance polish wax or mild liquid dishwashing detergent. Dry and polish with a clean, soft cloth. Do not wipe the freezer with a soiled dishwashing cloth or wet towel. Do not use scouring pads, powdered cleaners, bleach, or cleaners containing bleach.

NOTICE: Care should be taken in moving the freezer away from the wall. All types of floor coverings can be damaged, particularly cushioned coverings and those with embossed surfaces.

Inside. Clean the inside of your freezer at least once a year. We recommend that the freezer be unplugged before cleaning. If this is not practical, wring excess moisture out of sponge or cloth when cleaning in the vicinity of switches, lights or controls.

Use warm water and baking soda solution— about a tablespoon of baking soda to a quart of water. Rinse thoroughly with water and wipe dry. Do not use cleaning powders or other abrasive cleaners. DO NOT wash removable parts in a dishwasher.

An open box of baking soda in the freezer will absorb stale freezer odors. Change the box every three months.

Some upright freezers are frost-free and defrost automatically, but should be cleaned occasionally.

No Defrosting (on No-Frost models)

You never have to defrost your new No-Frost freezer. It has been pre-set at the factory to defrost itself automatically.

During defrosting, a slight noise may be noticed if the door is opened while the freezer is in the automatic defrosting cycle.

To Remove the Freezer Door (on Non-Electronic Control models)

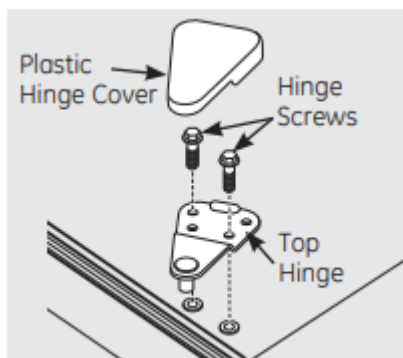

(on some models)

1. Remove the plastic hinge cover by either lifting it off or folding it back (depending on model).
2. Remove the screws holding the hinge to the top of the cabinet using a screwdriver, 5/16" socket driver or wrench (depending on model).
3. Remove the top hinge from the cabinet and lift the door up and off the lower hinge pin. Set the door aside.
4. Remove the two screws from the bottom hinge. To replace the doors, reverse the order of the above instructions.

NOTICE: It is very important that all hinge screws are securely tightened to ensure a secure assembly and prevent hinge slippage.

To Remove the Freezer Door (on Electronic Control models)

The hinge screws are tamperproof. Please have an authorized service technician remove the door.

In Case of Extended Power Failure

Keep freezer door closed. Your freezer will keep food frozen for 24 hours provided warm air is not admitted.

If freezer is out of operation for 24 hours or more, add dry ice. Leave ice in large pieces. Add more ice as required.

If dry ice is not available, move food to a frozen food locker temporarily - until power is restored.

Preparing to Move

Disconnect the power cord plug from the wall outlet. Remove foods, defrost (on Manual Defrost models) and clean the freezer.

Secure all loose items such as grille and shelves by taping them securely in place to prevent damage.

Be sure freezer stays in upright position during actual moving and during transportation. The freezer must be secured during transportation to prevent movement. Protect outside of freezer with blanket.

Preparing for Vacation

To maintain freezer in operation during vacations, be sure your house power is not turned off. For sure protection of freezer contents, you may want to ask a neighbor to check the power supply and freezer operation every 48 hours.

For extended vacations or absences, you may prefer to move your frozen foods to a storage locker temporarily. If your freezer is to be left empty, disconnect power cord plug from wall outlet. To prevent formation of odors, place open box of baking soda in freezer and leave freezer door open.

When the freezer is not operating, it can be left in an unheated house or room without damage to cabinet or mechanism.



The freezer should be located in the coolest area of the room, away from heatproducing appliances or heating ducts, and out of direct sunlight.

Let hot foods cool to room temperature before placing in the freezer. Overloading the freezer forces the compressor to run longer. Foods that freeze too slowly may lose quality or spoil.

Be sure to wrap foods properly, and wipe containers dry before placing them in the freezer. This cuts down on frost buildup inside the freezer.

Freezer shelves should not be lined with aluminum foil, wax paper or paper towels.

Liners interfere with cold air circulation, making the freezer less efficient.

Organize and label food to reduce door openings and extended searches. Remove as many items as needed at one time, and close the door as soon as possible.

Preparing to install the freezer

Read these instructions completely and carefully.

Freezer Location

Your freezer should be conveniently located for day-to-day use in a dry, well-ventilated room.

Do not install the freezer where the temperature will go below 0°F or above 110°F, because it will not maintain proper temperatures.

Be sure to install your freezer on a floor strong enough to support it when it is fully loaded.

Clearances

On all models, allow 3" (76 mm) on top, back and sides for proper air circulation.

Adjustable Legs

Legs at the front corners of the freezer should be set so the freezer is firmly positioned on the floor, and the front is raised just enough so the door closes easily when opened about halfway.

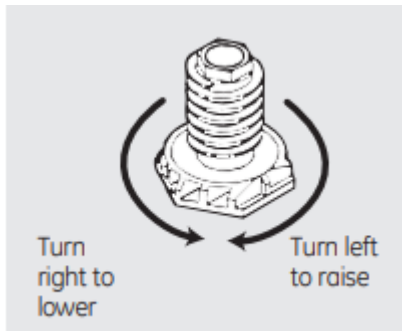

Level Freezer

Use a carpenter's level to level the freezer from back to front. Adjust the plastic leveling feet in front 1/2 bubble higher so the door closes easily when left open.

Unit Loading

NOTICE: To allow the door to close and seat properly, DO NOT let food packages extend past the front of the shelves.

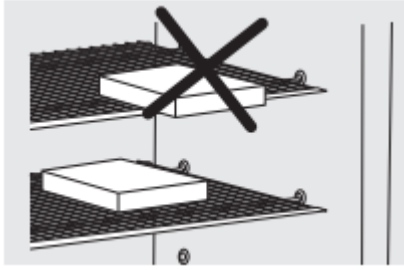

Before you call for service...



Problem	Possible Causes	What To Do
Freezer does not operate or Power-On Light is not on	Temperature control in OFF position.	Move the control to a temperature setting.
	Freezer is unplugged.	Push the plug completely into the outlet.
	The fuse is blown/circuit breaker is tripped.	Replace fuse or reset the breaker.
Freezer starts/stops too frequently	Door left open.	Check to see if package is holding door open.
	Too frequent or too long door openings.	Open the door less often.
	Temperature control set too cold.	See About the operation of your freezer.
Freezer operates too long	Door left open.	Check to see if package is holding door open.
	Too frequent or too long door openings.	Open the door less often.
	Temperature control set too cold.	See About the operation of your freezer.
	Inadequate air circulation space around cabinet.	See Preparing to install the freezer.
	Room or outside weather is hot.	It's normal for the freezer to work harder under these conditions.
	Freezer has been disconnected recently for a period of time.	It takes 4 hours for the freezer to cool down completely.
	Large amounts of warm or hot food have been stored recently.	Warm food will cause the freezer to run more until the desired temperature is reached.

Noisy operation or cabinet vibrates	Floor may be weak, causing freezer to vibrate when compressor is on.	Check to make sure freezer is located on solid floor and adjust leveling legs as needed.
	Cabinet is not positioned solidly on floor.	Adjust legs. See Preparing to install the freezer. Or use shims for uneven floor.
	Freezer is touching the wall.	Level freezer or move slightly. See Level Freezers.
Freezer temperature too warm	Door left open.	Check to see if package is holding door open.
	Too frequent or too long door openings	Open the door less often.
	Temperature control is set too warm.	Turn control to a colder setting. Allow several hours for the temperature to stabilize.
	Large amounts of water or hot food may have been stored recently.	Wait until the freezer has had a chance to reach its selected temperature.
	Freezer has been disconnected recently.	Freezer requires 4 hours to cool down completely.
Foods defrosting	Temperature control in OFF position.	Move the control to a temperature setting.
	Freezer is unplugged.	Push the plug completely into the outlet.
	The fuse is blown/circuit breaker is tripped.	Replace fuse or reset the breaker.
	Door left open.	Check to see if package is holding door open.
	Too frequent or too long door openings.	Open the door less often.



Freezer temperature too cold	Temperature control set too cold.	See About the operation of your freezer.
Moisture forms on outside of cabinet	Not unusual during periods of high humidity.	Wipe surface dry.
	Door may not be seating properly, causing cold air from inside the freezer to meet warm moist air from the outside.	See Preparing to install the freezer.
Interior light does not work (on some models)	No power at outlet.	Replace fuse or reset the breaker.
	Freezer is unplugged.	Push the plug completely into the outlet.
	Light bulb burned out.	Replace bulb.
Door won't fully close by itself	Legs need adjusting.	See Preparing to install the freezer.
	Package holding door open.	Move package to a different location.
Slow starting time after being off	Built-in overload protection.	This is normal after being off.
Excessive frost buildup	Door left open.	Check to see if package is holding door open.
	Too frequent or too long door openings.	Open the door less often.
	Not unusual during periods of high humidity.	Wipe surface dry.
Freezer external surface temperature is warm	The external freezer walls can be as much as 30°F warmer than room temperature.	This is normal while the compressor works to transfer heat from inside the freezer cabinet.

Louder sound levels whenever freezer is on	Modern freezers have increased storage capacity and more stable temperatures. They require a high-efficiency compressor.	This is normal. When the surrounding noise level is low, you might hear the compressor running while it cools the interior.
Higher sound levels when compressor comes on	Freezer operates at higher pressures during the start of the ON cycle.	This is normal. Sound will level off or disappear as freezer continues to run.
Popping or cracking sound when compressor comes on	Metal parts undergo expansion and contraction, as in hot water pipes.	This is normal. Sound will level off or disappear as freezer continues to run.
Bubbling or gurgling sound, like boiling water	Refrigerant (used to cool freezer) is circulating throughout the system.	This is normal.
Moisture forms on inside freezer walls	Weather is hot and humid, which increases internal rate of frost buildup.	This is normal.
	Door may not be seating properly.	See Preparing to install the freezer.
	Door is kept open too long, or is opened too frequently.	Open the door less often.
Odors in freezer	Interior needs to be cleaned.	Clean interior with sponge, warm water and baking soda.
	Foods with strong odors are in the freezer.	Cover the food tightly.

Warning

This content is compiled from multiple sources and is provided for reference purposes only. It may not be complete or fully applicable to all situations. If you are unable to resolve your issue, please contact the product manufacturer or an authorized service provider for official support.



