

USING YOUR OVEN

Features

1150 Watts

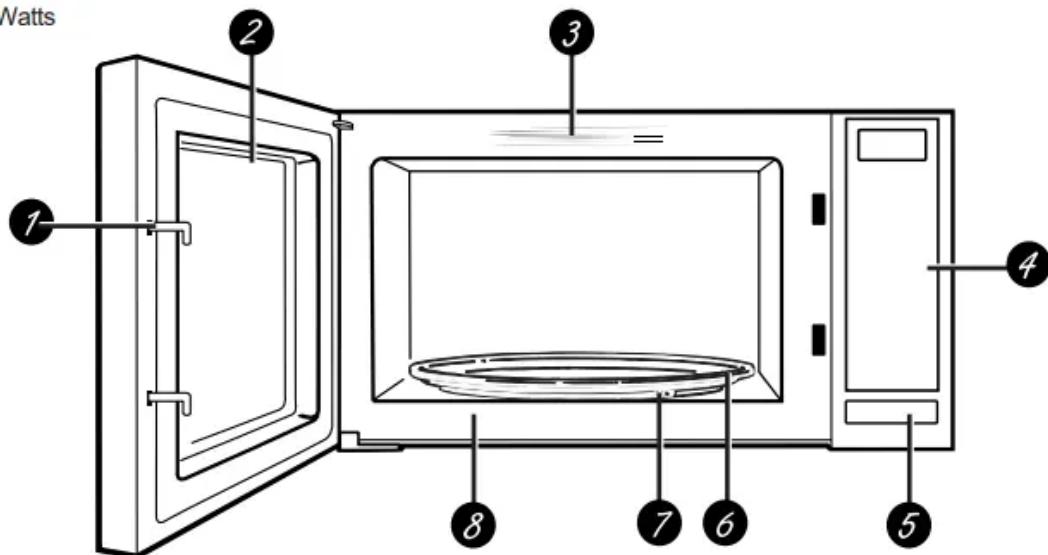

1 Door Latches

2 Window with Metal Shield. Screen allows cooking to be viewed while keeping microwaves confined in the oven.

3 Convenience Guide

4 Touch Control Panel Display

5 Door Latch Release. Press latch release to open door

6 Removable Turntable. Turntable and support must be in place when using the oven. The turntable may be removed for cleaning.

7 Removable Turntable Support. The turntable support must be in place when using the oven.

8 Rating Plate.

Changing the power level

Changing the Power Level: the power level can be changed only when using Cook Time or Time Defrost buttons and is explained in the sections for the functions of these buttons. Variable power levels add flexibility to microwave cooking. The power levels on the microwave oven can be compared to the surface units on a range. Each power level gives you microwave energy a certain percent of the time. Power level 7 is microwave energy 70% of the time. Power level 3 is energy 30% of the time. Most cooking will be done on power level 10 which gives you 100% power. Power level 10

will cook faster but food may need more frequent stirring, rotating or turning over. A lower setting will cook more evenly and need less stirring or rotating of the food. Some foods may have better flavor, texture or appearance if one of the lower settings is used. Use a lower power level when cooking foods that have a tendency to boil over, such as scalloped potatoes.

Rest periods (when the microwave energy cycles off) give time for the food to “equalize” or transfer heat to the inside of the food. An example of this is shown with power level 3—the defrost cycle. If microwave energy did not cycle off, the outside of the food would cook before the inside was defrosted. Here are some examples of uses for various power levels:

10: Fish, bacon, vegetables, boiling liquids.

Med-High 7: Gentle cooking of meat and poultry; baking casseroles and reheating.

Medium 5: Slow cooking and tenderizing for stews and less tender cuts of meat.

Low 2 or 3: Defrosting; simmering; delicate sauces.

Warm 1: Keeping food warm; softening butter.

About the features

Humidity Sensor

The Sensor Features detect the increasing humidity released during cooking. The oven automatically adjusts the cooking time to various types and amounts of food. Do not use the Sensor Features twice in succession on the same food portion—it may result in severely overcooked or burnt food. Be sure to let the oven cool down for 5-10 minutes before starting the next sensor cook. If food is undercooked after the countdown, use Cook Time for additional cooking time.

- The proper containers and covers are essential for best sensor cooking.
- Always use microwavesafe containers and cover them with lids or vented plastic wrap. Never use tight sealing plastic containers - they can prevent steam from escaping and cause food to overcook.
- Be sure the outside of the cooking containers and the inside of the microwave oven are dry before placing food in the oven. Beads of moisture turning into steam can mislead the sensor.



Covered



Vented



Dry off dishes so they don't mislead the sensor.

About the features



Cook Time

Allows you to microwave from 1 second to 99 minutes and 99 seconds.

1. Press Cook Time.
2. Enter cooking time.
3. Power level is automatically set to 10, but if you want to reduce it, press Power, then select a level from 0 to 9.
4. Press Start.

You may open the door during Cook Time to check the food. Close the door and press START to resume cooking.

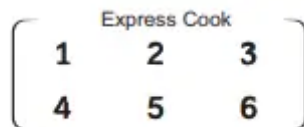

Express Cook

This is a quick way to set cooking time from 1-6 minutes.

1. Press one of the Express Cook pads (from 1-6) for 1-6 minutes of cooking at power level 10. For example, press the 2 pad for 2 minutes of cooking time.

The power level can be changed as time is counting down. Press POWER LEVEL and enter 1-10.

NOTE: Express Cook function pertains to pads 1-6 only.

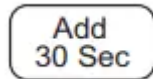

Add 30

Sec It will add 30 seconds to the time counting down each time the pad is pressed. Each touch will add 30 seconds, up to 99 minutes and 99 seconds. The oven will start immediately when pressed.



Use only with prepackaged
microwave popcorn weighing
2.5 to 3.0 ounces.

Popcorn

To use the Popcorn feature:

1. Follow package instructions, using Cook Time if the package is less than 2.5 ounces or larger than 3.0 ounces. Place the package of popcorn in the center of the microwave.
2. Press Popcorn.
3. The microwave will start immediately.

IMPORTANT: Do not use the sensor features twice in succession on the same food portion. If food is undercooked after the first countdown, use Cook Time for additional time.

Reheat

Cover with lid or vented plastic wrap.

1. Press Reheat pad.
2. Enter 1, 2, or 3 for the food code – refer to the Cooking Guide for REHEAT. The oven starts immediately.

Do not open the door while the oven is operating.

IMPORTANT: Do not use the sensor features twice in succession on the same food portion. If food is undercooked after the first countdown, use Cook Time for additional time.

Reheat

Cooking Guide for REHEAT feature		
Enter Code	Food Choice	Weight Range
1	Pasta	4-16 oz.
2	Fruits and Vegetables	4-16 oz.
3	Dinner plate	8-24 oz.

Beverage

Beverage

To use the Beverage feature: Press BEVERAGE pad. The microwave will automatically be set to heat an 8 ounce beverage. The microwave will start immediately. Drinks heated with the Beverage feature may be very hot. Remove the container with care. IMPORTANT: Do not use the sensor features twice in succession on the same food portion. If food is undercooked after the first countdown, use Cook Time for additional time

Potato

To use the Potato feature:

1. Press the POTATO pad.
2. Enter quantity (1-4 pcs at 6-8 oz. each:
3. The microwave will start immediately.

IMPORTANT: Do not use the sensor features twice in succession on the same food portion. If food is undercooked after the first countdown, use Cook Time for additional time

Vegetable

Vegetable

To use the Vegetable feature:.

1. Press VEGETABLE pad.
2. Enter the Vegetable code. See Cooking Guide for Vegetables below for codes.
3. The microwave will start immediately.

IMPORTANT: Do not use the sensor features twice in succession on the same food portion. If food is undercooked after the first countdown, use Cook Time for additional time.

Cooking Guide for VEGETABLE Feature

Vegetable Code	Type of Vegetables	Available Servings	Ounces per Serving
1	Fresh	4-16 oz.	4 ounces per serving
2	Frozen	4-16 oz.	4 ounces per serving
3	Canned	1-4 servings	4 ounces per serving



Dinner Plate

To use the Dinner Plate feature:

1. Press the Dinner Plate.
2. Press 1, 2 or 3 (1 is for 8 oz. of food, 2 is for 12 oz. of food, and 3 is for 16 oz. of food).
3. The microwave will start immediately.

IMPORTANT: Do not use the sensor features twice in succession on the same food portion. If food is undercooked after the first countdown, use Cook Time for additional time.

Defrosting

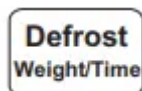

Defrost

Allows you to defrost either by weight or by time. The Defrosting Guide below provides time recommendations.

1. For Weight Defrost, press the Defrost Weight/Time button until it shows "LBS" in the display.
2. Enter weight (from .1 to 6 lbs) then press Start.
3. For Time Defrost, press the Defrost Weight/Time button until it shows "TIME" in the display.
4. Enter the time (from 1 second to 99 minutes and 99 seconds), then press Start.
5. Press Start/Pause. At one half of selected defrosting time, turn food over and break apart or rearrange pieces for more even defrosting. Shield any warm

areas with small pieces of foil. The oven will continue to defrost if you don't open the door and turn the food.

A dull thumping noise may be heard during defrosting. This is normal when oven is not operating at power level 10.

Defrosting Tips

- Foods frozen in paper or plastic can be defrosted in the package. Closed packages should be slit, pierced or vented AFTER food has partially defrosted. Plastic storage containers should be partially uncovered.
- Family-size, prepackaged frozen dinners can be defrosted and microwaved. If the food is in a foil container, transfer it to a microwave-safe dish.
- Foods that spoil easily should not be allowed to sit out for more than one hour after defrosting. Room temperature promotes the growth of harmful bacteria.
- For more even defrosting of larger foods, such as roasts, use Weight Defrost. Be sure large meats are completely defrosted before cooking.
- When defrosted, food should be cool but softened in all areas. If still slightly icy, return to the microwave very briefly, or let it stand a few minutes.

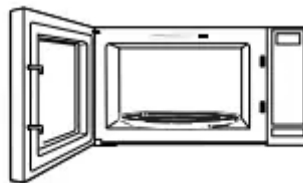

There is a handy guide located on the inside front of the oven.

- Remove meat from package and place on microwavesafe dish.
- When the oven signals, turn the food over. Remove defrosted meat or shield warm areas with small pieces of foil.
- After defrosting, most meats need to stand 5 minutes to complete defrosting. Large roasts should stand for about 30 minutes.

Defrosting Guide		
Food	Time	Comments
Breads, Cakes <i>Bread, buns, or rolls</i> (1 piece) <i>Sweet rolls</i> (approx. 12 oz.)	1/4 min. 2 to 4 min.	Rearrange after half the time.
Fish and Seafood <i>Fillet, frozen</i> (1 lb.) <i>Shellfish, small pieces</i> (1 lb.)	6 to 9 min. 3 to 7 min.	Place block in casserole. Turn over and break up after half the time.
Fruit <i>Plastic pouch—1 or 2</i> (10-oz. package)	1 to 5 min.	
Meat <i>Bacon</i> (1 lb.) <i>Franks</i> (1 lb.) <i>Ground meat</i> (1 lb.) <i>Roast: beef, lamb, veal, pork</i> <i>Steaks, chops and cutlets</i>	2 to 5 min. 2 to 5 min. 4 to 6 min. 9 to 13 min. per lb. 4 to 8 min. per lb.	Place unopened package in oven. Let stand 5 minutes after defrosting. Place unopened package in oven. Microwave just until franks can be separated. Let stand 5 minutes, if necessary, to complete defrosting. Turn meat over after first half of time. Use power level 10. Place unwrapped meat in cooking dish. Turn over after first half of time and shield warm areas with foil. After second half of time, separate pieces with table knife. Let stand to complete defrosting.
Poultry <i>Chicken, broiler-fryer, cut up</i> (2½ to 3 lbs.) <i>Chicken, whole</i> (2½ to 3 lbs.) <i>Cornish hen</i> <i>Turkey breast</i> (4 to 6 lbs.)	14 to 20 min. 20 to 25 min. 7 to 13 min. per lb. 3 to 8 min. per lb.	Place wrapped chicken in dish. Unwrap and turn over after first half of time. After second half of time, separate pieces and place in cooking dish. Microwave 2 to 4 minutes more, if necessary. Let stand a few minutes to finish defrosting. Place wrapped chicken in dish. After half the time, unwrap and turn chicken over. Shield warm areas with foil. To complete defrosting, run cold water in the cavity until giblets can be removed. Place unwrapped hen in the oven breast-side-up. Turn over after first half of time. Run cool water in the cavity until giblets can be removed. Place unwrapped breast in microwave-safe dish breast-side-down. After first half of time, turn breast-side-up and shield warm areas with foil. Defrost for second half of time. Let stand 1 to 2 hours in refrigerator to complete defrosting.

About the other features



Clock

Press to enter the time of day.

1. Press Clock.
2. Enter time of day.
3. Press Clock

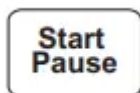

Pause

Start/Pause allows you to stop cooking without opening the door or clearing the display. Press Start/Pause again to restart the oven.



Child Lock-Out

You may lock the control panel to prevent the microwave from being accidentally started or used by children. To lock or unlock the controls, press and hold Cancel/Off for about three seconds. When the control panel is locked, the display shows “LOC”.

Pizza

Pizza

To use the Pizza feature:

1. Press the Pizza.
2. Enter number of slices of pizza (1, 2, 3, or 4).
3. Press Start/Pause.

**Timer
On/Off**

Timer

The Timer operates without microwave energy.

1. Press Timer On/Off.
2. Enter the amount of time you want to count down.
3. Press Timer On/Off. When the time is up, the timer will beep.
4. To stop or clear the timer, press Timer On/Off.

CARE AND CLEANING

Helpful

Hints An occasional thorough wiping with a solution of baking soda and water keeps the inside fresh. Unplug the cord before cleaning any part of this oven.



How to Clean the Inside

Walls, Floor, Inside Window, Metal and Plastic Parts on the Door

Some spatters can be removed with a paper towel; others may require a damp cloth. Remove greasy spatters with a sudsy cloth, then rinse with a damp cloth. Do not use abrasive cleaners or sharp utensils on oven walls.

To clean the surface of the door and the surface of the oven that come together upon closing, use only mild, nonabrasive soaps or detergents using a sponge or soft cloth. Rinse with a damp cloth and dry.

Never use a commercial oven cleaner on any part of your microwave.

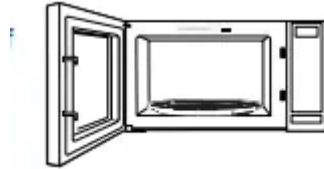

Removable Turntable and Turntable Support

To prevent breakage, do not place the turntable into water just after cooking. Wash it carefully in warm, sudsy water or in the dishwasher. The turntable and support can be broken if dropped. Remember, do not operate the oven in the microwave mode without the turntable and support seated and in place.

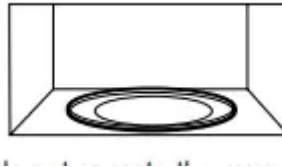

How to Clean the Outside

Do not use cleaners containing ammonia or alcohol on the microwave oven. Ammonia or alcohol can damage the appearance of the microwave.

Case

Clean the outside of the microwave with a sudsy cloth. Rinse with a damp cloth and then dry. Wipe the window clean with a damp cloth.

Control Panel and Door

Wipe with a damp cloth. Dry thoroughly. Do not use cleaning sprays, large amounts of soap and water, abrasives or sharp objects on the panel—they can damage it. Some paper towels can also scratch the control panel.

Door Surface

It is important to keep the area clean where the door seals against the microwave. Use only mild, nonabrasive detergents applied with a clean sponge or soft cloth. Rinse well.

Power Cord

If the cord becomes soiled, unplug and wash with a damp cloth. For stubborn spots, sudsy water may be used, but be certain to rinse with a damp cloth and dry thoroughly before plugging cord into outlet.

Stainless Steel (on some models)

Do not use a steel-wood pad; it will scratch the surface. To clean the stainless steel surface, use a hot, damp cloth with a mild detergent suitable for stainless steel surfaces. Use a clean, hot, damp cloth to remove soap. Dry with a dry, clean cloth. Always scrub lightly in the direction of the grain.

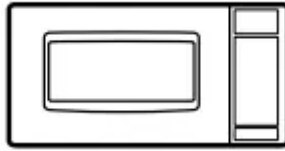

TROUBLESHOOTING

Problem	Possible Cause
Oven will not come on	A fuse in your home may be blown or the circuit breaker tripped. Replace fuse or reset circuit breaker
	Unplug your microwave oven, then plug it back in
	Make sure 3-prong plug on oven is fully inserted into wall receptacle.
Control panel lighted, yet oven will not start	Door not securely closed
	Start must be pressed after entering cooking selection.
	Another selection entered already in oven and Cancel/Off not pressed to cancel it
	Make sure you have entered cooking time after pressing Cook Time.
	Cancel/Off was pressed accidentally. Reset cooking program and press Start
	Make sure you entered food weight after pressing Defrost Weight. Oven was paused accidentally. Press Start to restart the cooking program.
"FOOD" appears on display	The control detected that the door has not been opened (food/beverage has not been placed inside).
"LOC" appears on display	The control panel has been locked. (When the control panel is locked, "LOC" will be displayed.) Press and hold Cancel/Off for about 3 seconds to unlock the control panel.
"PF" appears on display	A Power Failure has occurred. Press Cancel/Off to clear the display.
"ERR" appears on display	Occurs when the door is opened during a sensor function. Press Cancel/Off to clear the display

SAFETY INFORMATION

IMPORTANT SAFETY INSTRUCTIONS

When using electrical appliances, basic safety precautions should be followed, including the following:

- Read all instructions before using this appliance.
- Read and follow the specific precautions in the PRECAUTIONS TO AVOID POSSIBLE EXPOSURE TO EXCESSIVE MICROWAVE ENERGY section on page 5.
- Use this appliance only for its intended use as described in this manual. Do not use corrosive chemicals or vapors in this appliance. This microwave oven is specifically designed to heat, dry or cook food, and is not intended for laboratory or industrial use.
- This appliance should be serviced only by qualified service personnel. Contact nearest authorized service facility for examination, repair, or adjustment.

INSTALLATION

- Install or locate this appliance only in accordance with the provided installation instructions.
- This appliance must be grounded. Connect only to a properly grounded outlet. See the GROUNDING INSTRUCTIONS section on page 5.
- Be certain to place the front surface of the door 3 inches or more back from the counter top edge to avoid accidental tipping of the appliance in normal usage.
- Recommended clearances: 3 inches on each side, 3 inches on the top, and 1 inch in the rear.
- Do not operate this appliance if it has a damaged power cord or plug, if it is not working properly, or if it has been damaged or dropped.
- Keep power cord away from heated surfaces.
- Do not let cord hang over edge of table or counter.
- Do not immerse power cord or plug in water.
- Do not cover or block any opening on the appliance.
- Do not store this appliance outdoors. Do not use this product near water - for example, in a wet basement, near a swimming pool, or in a similar location.
- Do not mount over a sink.

TO REDUCE THE RISK OF FIRE IN THE CAVITY:

—Do not overcook food. Carefully attend appliance when paper, plastic or other combustible materials are placed inside the oven while cooking.

—Remove wire twist-ties and metal handles from paper or plastic containers before placing them in the oven.

—If materials inside the oven ignite, keep the oven door closed, turn the oven off and disconnect the power cord, or shut off power at the fuse or circuit breaker panel.

—Do not store any materials in the oven when not in use. Do not leave paper products, cooking utensils, or food in the cavity when not in use. All racks should be removed from oven when not in use.

—Do not operate the microwave feature without food in the oven.

TO REDUCE THE RISK OF BURNS

- Be careful when opening containers of hot food. Use pot holders and direct steam away from face and hands.
- Vent, pierce, or slit containers, pouches or plastic bags to prevent build-up of pressure.
- Be careful when touching the turntable, door, rack or walls of the oven which may become hot during use.
- Liquids and certain foods heated in the microwave oven can present a risk of burn when removing them from the microwave. The potential for a burn is greater in young children, who should not be allowed to remove hot items from the microwave.

OPERATING

- As with any appliance, close supervision is necessary when used by children.
- Do not operator the oven without the turntable in place. The turntable must be unrestricted so it can turn.
- Make sure all cookware used in your microwave oven is suitable for microwaving. Most glass casseroles, cooking dishes, measuring cups, custard cups, pottery or china dinnerware which does not have metallic trim or glaze with a metallic sheen can be used in compliance with cookware manufacturers' recommendations.
- Do not store anything directly on top of the microwave surface when the microwave is in operation.
- Some products such as whole eggs and sealed containers - for example, closed jars - are able to explode and should not be heated in the microwave oven.
- Do not overcook potatoes. The could dehydrate and catch fire.
- Do not cover any other part of the oven with metal foil. This will cause overheating of the oven.

- Cook meat and poultry thoroughly—meat to at least an INTERNAL temperature of 160°F and poultry to at least an INTERNAL temperature of 180°F. Cooking to these temperatures usually protects against foodborne illness.
- This oven is not approved or tested for marine use.

CLEANING

- Keep the oven free from grease buildup.
- Do not clean with metal scouring pads. Pieces can burn off the pad and touch electrical parts involving risk of electric shock.
- When cleaning surfaces of door and oven that comes together on closing the door, use only mild, nonabrasive soaps, or detergents applied with a clean sponge or soft cloth. Rinse well.

SUPER HEATED WATER

- Liquids, such as water, coffee, or tea, are able to be overheated beyond the boiling point without appearing to be boiling. Visible bubbling or boiling when the container is removed from the microwave oven is not always present. THIS COULD RESULT IN VERY HOT LIQUIDS SUDDENLY BOILING OVER WHEN THE CONTAINER IS DISTURBED OR A SPOON OR OTHER UTENSIL IS INSERTED INTO THE LIQUID.
- To reduce the risk of injury to persons:
 - Do not overheat the liquid.
 - Stir the liquid both before and halfway through heating it.
 - Do not use straight-sided containers with narrow necks.
 - After heating, allow the container to stand in the microwave oven for a short time before removing the container.
 - Use extreme care when inserting a spoon or other utensil into the container.

Warning

This content is compiled from multiple sources and is provided for reference purposes only. It may not be complete or fully applicable to all situations. If you are unable to resolve your issue, please contact the product manufacturer or an authorized service provider for official support.