

Getting to Know Your TV

FRONT PANEL





Remote Sensor and Power Indicator

When using the remote, aim it directly at this sensor.

The power indicator flashes on when the TV turns on, then goes out after several seconds.

To keep the power indicator on, see **Turning the Power Indicator On or Off on page 23.**

REAR PANEL



Note: The image shown here is for illustrative purposes only and may be subject to change. The actual number of ports and their locations may vary, depending on the model.





Power

Press to turn on the TV. Press and hold to turn the TV off.



Volume

Press to increase or decrease the TV volume level.



Input

Press to access the input menu.



HDMI

Connect an HDMI device



Composite

Connect a composite



Audio Out

Connect to an RCA device, such as sound bar





Coaxial

Connect to a coaxial cable from cable, satellite, or antenna



USB

Connect a USB thumb drive to play photo, music, or video



Optical Audio Out

Connect to an optical/SPDIF audio device, such as home audio receiver



Ethernet

Connect an Ethernet cable to modem/router

Connecting a device — AUDIO & VIDEO CABLE TYPES

Your TV can be used to display output from most devices.

1. Verify that your device has a video port that matches an available port on the TV (HDMI, Composite, etc.).
2. Connect the appropriate cable (not included) to the TV and the device.
3. Turn the TV and your device on.
4. Set the TV's input to match the connection you used (HDMI-1, HDMI-2, etc.).

HDMI CABLE

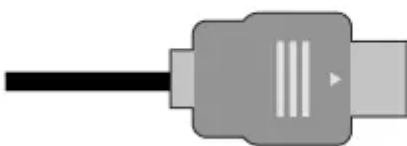

HDMI

COMPOSITE (AV) CABLE

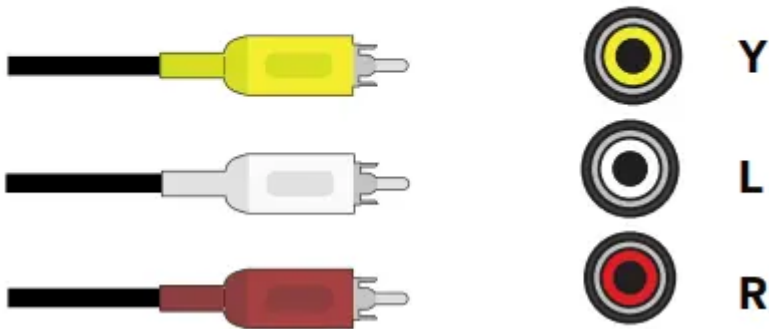

COAXIAL CABLE



Connecting a device — AUDIO CABLE TYPES

Your TV can be output sound to an audio device, such as a receiver or sound bar.

1. Verify that your device has an audio port that matches an available port on the TV (optical, RCA, etc).
2. Connect the appropriate cable (not included) to the TV and the device.
3. Turn the TV and your device on.

HDMI CABLE

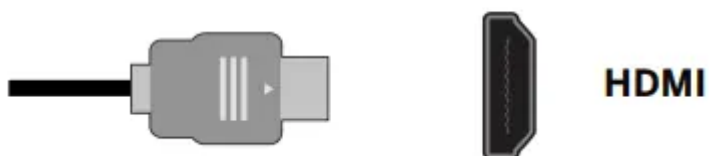

COMPONENT AND/OR COMPOSITE CABLE

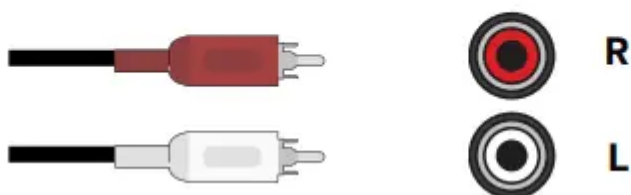

OPTICAL/SPDIF CABLE



Optical

USING THE REMOTE

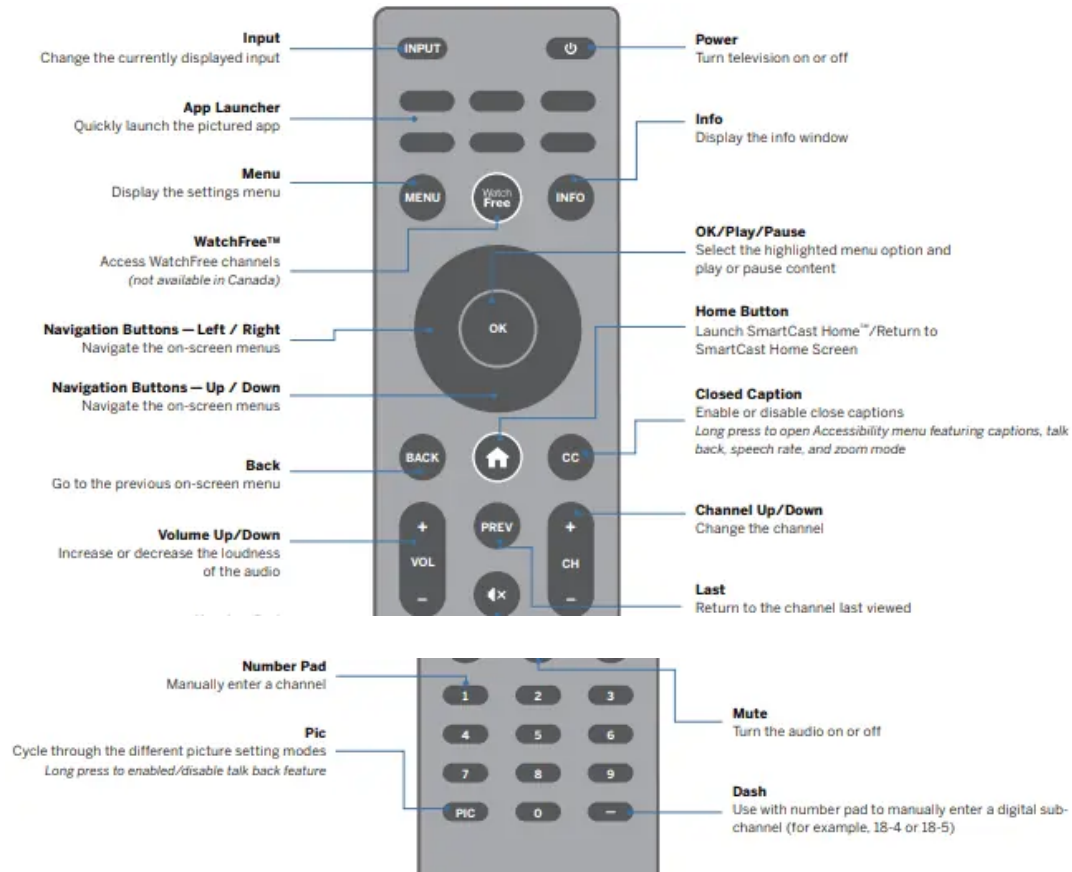

Replacing the Batteries

1. Push the bottom of the battery compartment and lift battery cover to open.
2. Insert two batteries into the remote control. Make sure that the (+) and (-) symbols on the batteries match the (+) and (-) symbols inside the battery compartment.
3. Replace the battery cover and click to close.

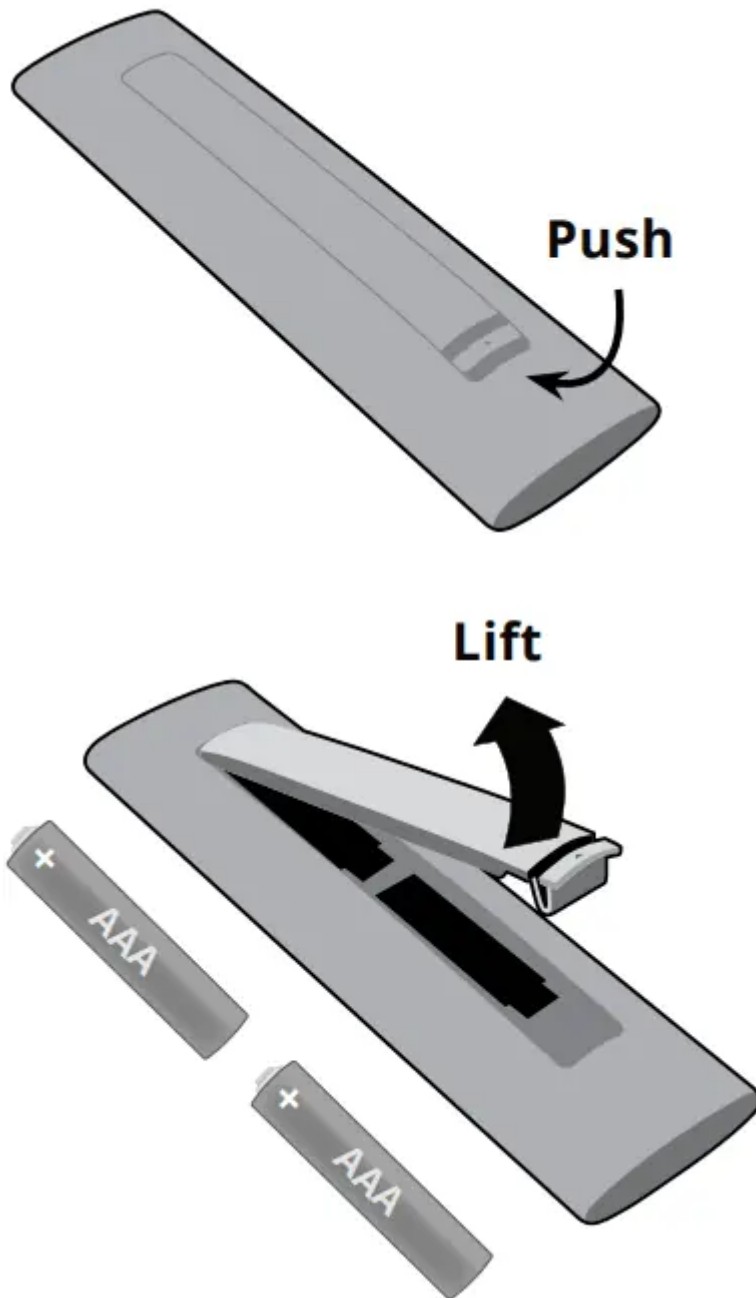

Completing the First-Time Setup

Before you begin the first-time setup:

- Your TV should be installed and the power cord should be connected to an electrical outlet.
- If you have a wireless network, have the network password ready.
- If you are connecting to your network with an Ethernet cable, connect it to the Ethernet port on the TV.

The first time you turn on the TV, the on-screen instructions will guide you through each of the steps necessary to get your TV ready for use:

1. Choose your language. Pressing the CC button will enable TTS (text-to-speech) functionality

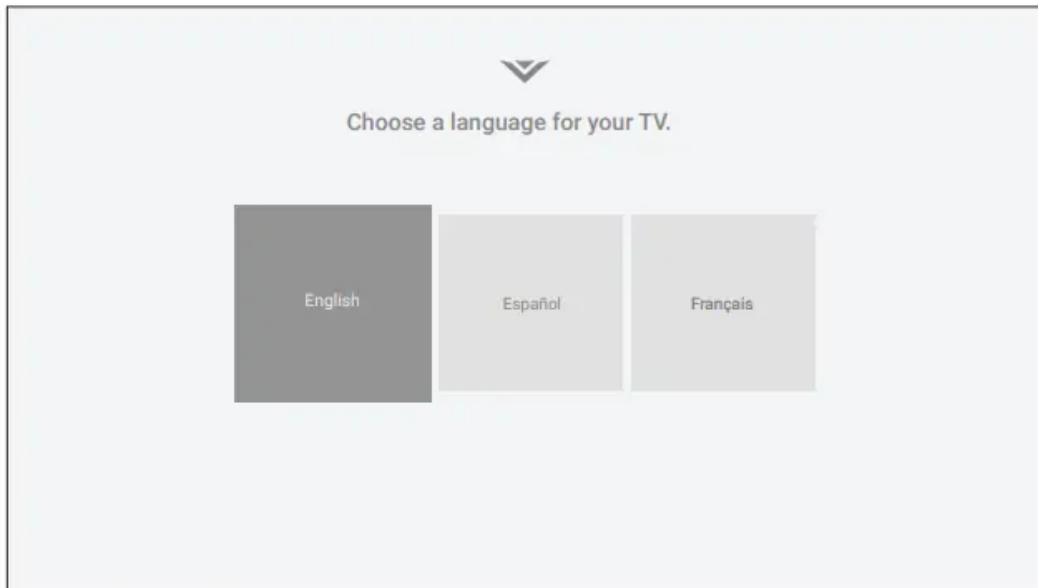

2. Choose home use.

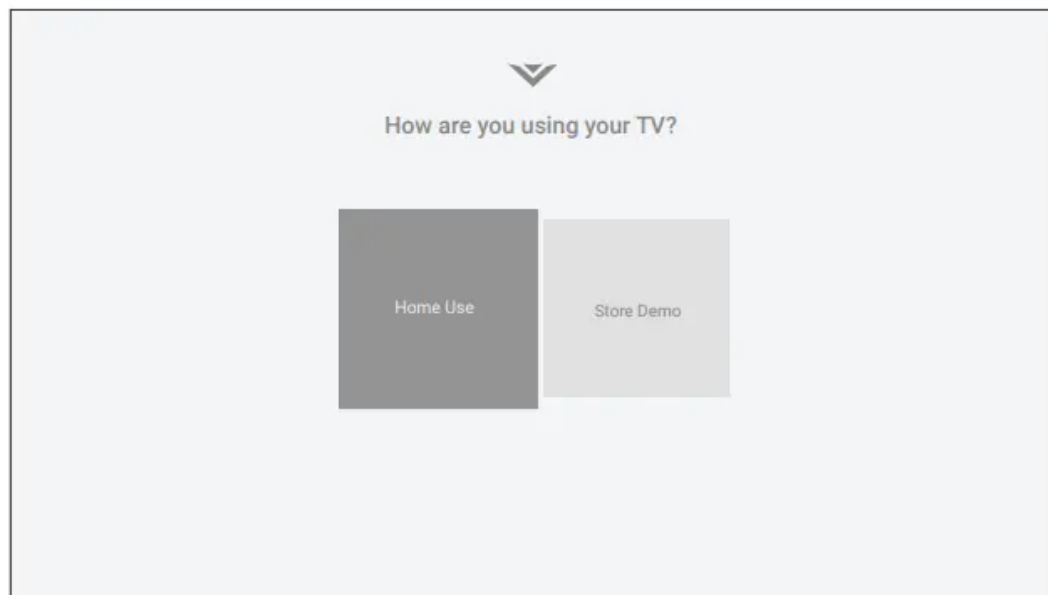

3. Choose your country

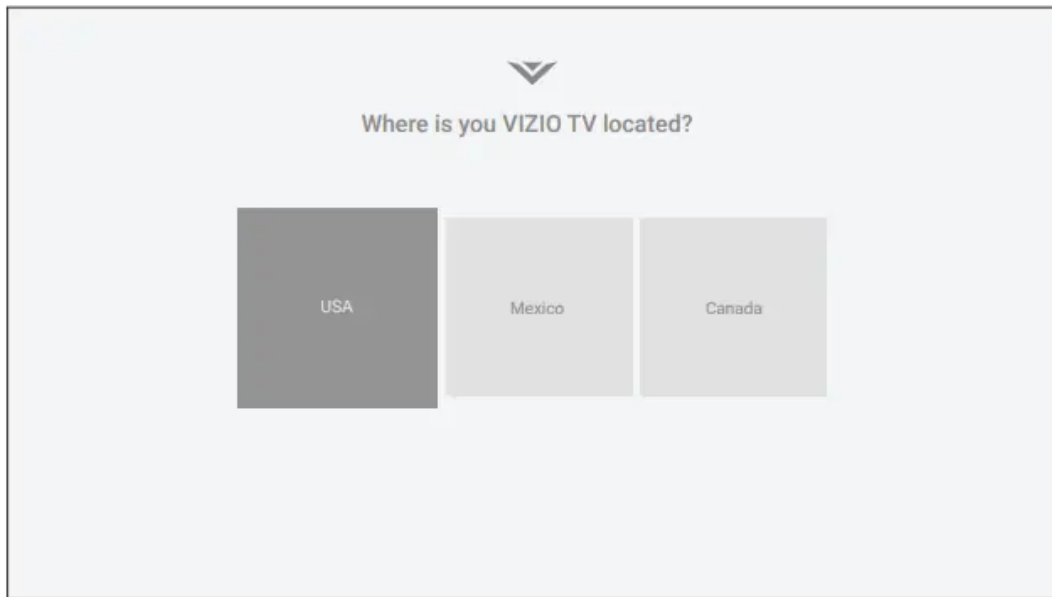

4. Choose your Wi-Fi network and enter the password.

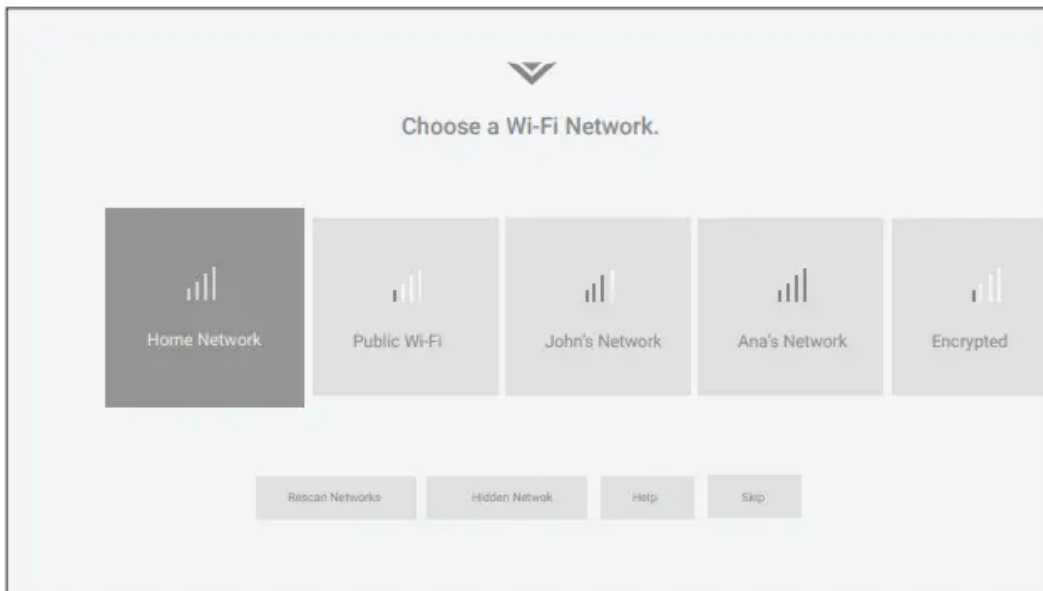

5. Name your TV.



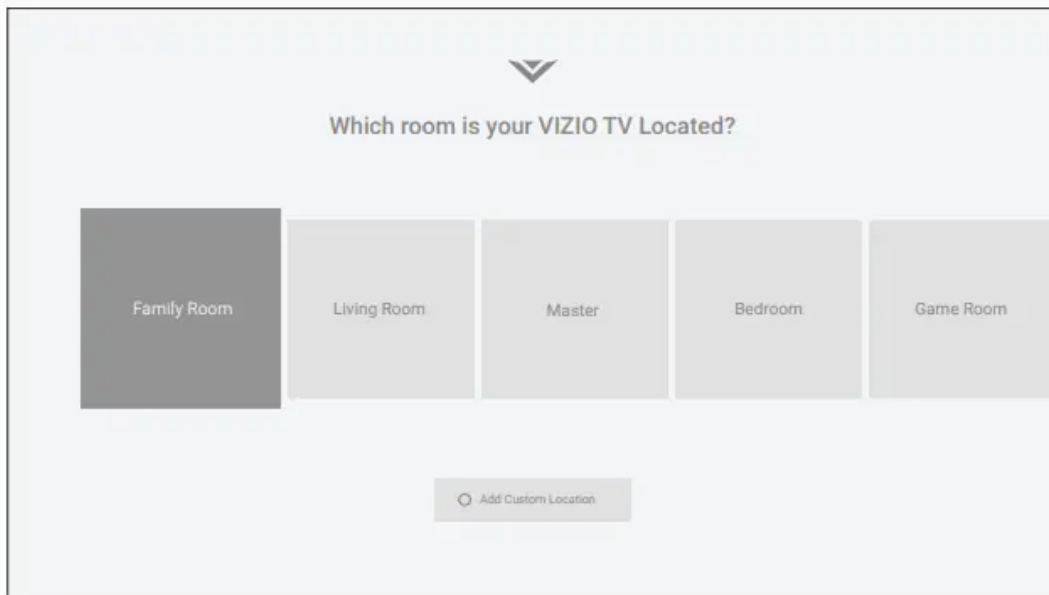

6. Scan for channels.

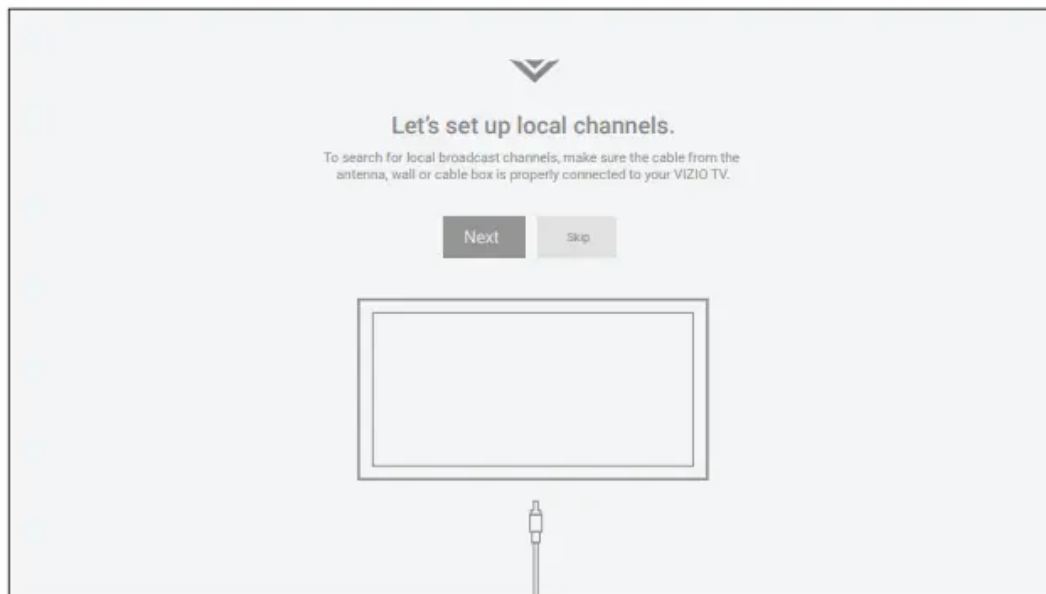

7. Accept the Terms & Conditions

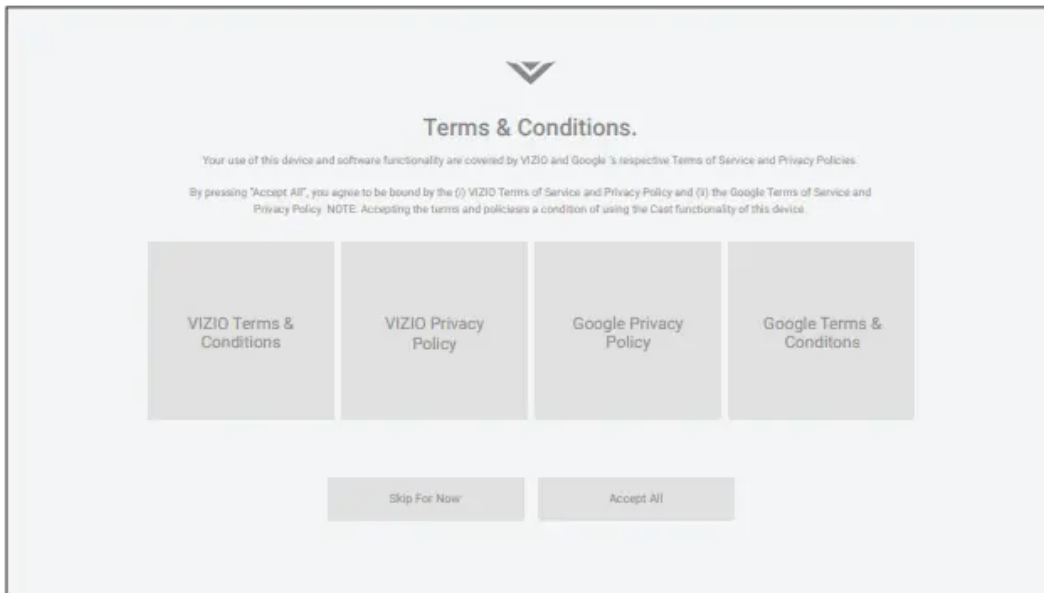

8. View and accept VIZIO Viewing Data Policy.

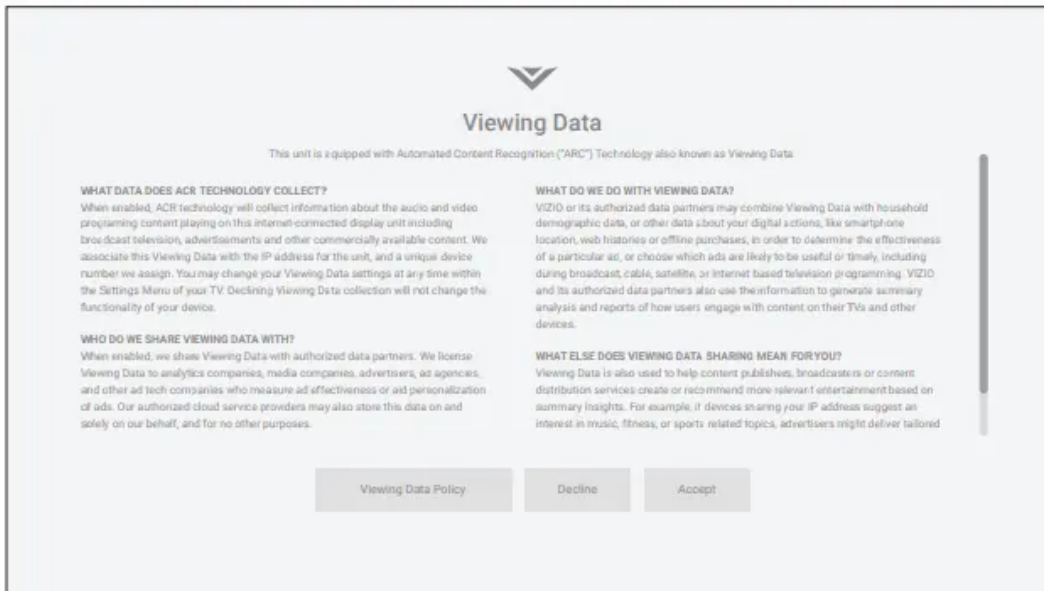

Using the On-Screen Menu

Your TV features an easy-to-use on-screen menu . To open the on-screen menu, press the MENU button on the remote.

From this menu, you can:

- Adjust the picture settings
- Adjust the audio settings
- Adjust the network settings
- Adjust the TV channel settings

- Adjust accessibility settings
- Adjust TV system settings
- Access admin and privacy settings
- View the user manual

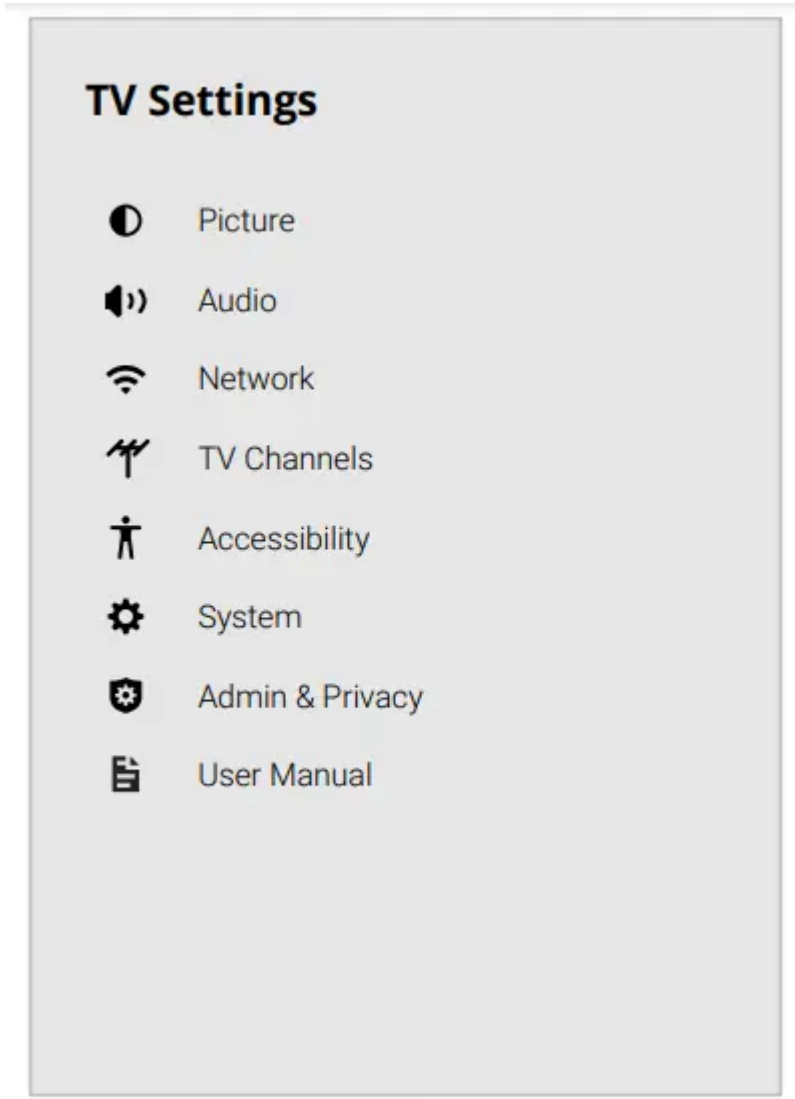

NAVIGATING THE ON-SCREEN MENU

To open the on-screen menu:

1. Press the MENU button on the remote.
2. Use the Navigation buttons to highlight a menu option, and press the OK button to select that option.

CHANGING THE INPUT SOURCE

External devices, such as DVD players, Blu-ray players, and video game consoles, can be connected to your TV. To use one of these devices with your TV, you must first change the input source using the input menu.

To change the input sources:

1. Press the INPUT button on the remote. The input menu is displayed.
2. Use the Navigation buttons or the INPUT button on the remote to highlight the input you wish to view. The corresponding inputs are named on the back of your TV.
3. Press OK or release the INPUT button. The selected input is displayed.



Input Name

The underlined input on the left is the current input selected. Inputs may vary by TV.

ADJUSTING THE PICTURE SETTINGS

Your TV can be adjusted to suit your preferences and viewing conditions.

To adjust the picture mode settings:

Menu > Picture > Picture Mode

1. Use the Navigation buttons on the remote to highlight Picture Mode, then use the Left/Right Navigation buttons to change the picture mode:
 - Vivid — Sets the picture settings to values that produce a brighter, more vivid picture.
 - Bright — Sets the picture settings to values ideal for watching TV in a brightly-lit room.
 - Calibrated — Sets the picture settings to the default settings.
 - Calibrated Dark — Sets the picture settings to values ideal for watching TV in a dark room.

- **Game** — Reduces throughput delays and optimizes the picture settings for displaying game console output. Also the preferred picture mode for computer mode.
- **Sports** — Sets the picture settings to values ideal for watching sport events with motion control setting.

2. To manually change each of the picture settings, use the Up/Down Navigation buttons on the remote to highlight that picture setting, then use the Left/Right Navigation buttons to adjust the setting:

- **Backlight (SDR content) or Tone Mapping (HDR content)** — Adjusts the LED brightness to affect the overall brilliance of the picture.
- **Brightness** — Adjusts the black level of the picture. When this setting is too low, the picture may be too dark to distinguish details. When this setting is too high, the picture may appear faded or washed out.
- **Contrast** — Adjusts the white level of the picture. When this setting is too low, the picture may appear dark. When this setting is too high, the picture may appear faded or washed out. If the setting is too high or too low, detail may be difficult to distinguish in dark or bright areas of the picture.
- **Color** — Adjusts the intensity of the picture colors.
- **Tint** — Adjusts the hue of the picture. This setting is useful in adjusting the flesh tones in the picture. If flesh appears too orange, reduce the level of color before adjusting tint.
- **Sharpness** — Adjusts the edge sharpness of picture elements. It can be used to sharpen non-HD (high definition) content; however, it will not produce detail that does not otherwise exist.

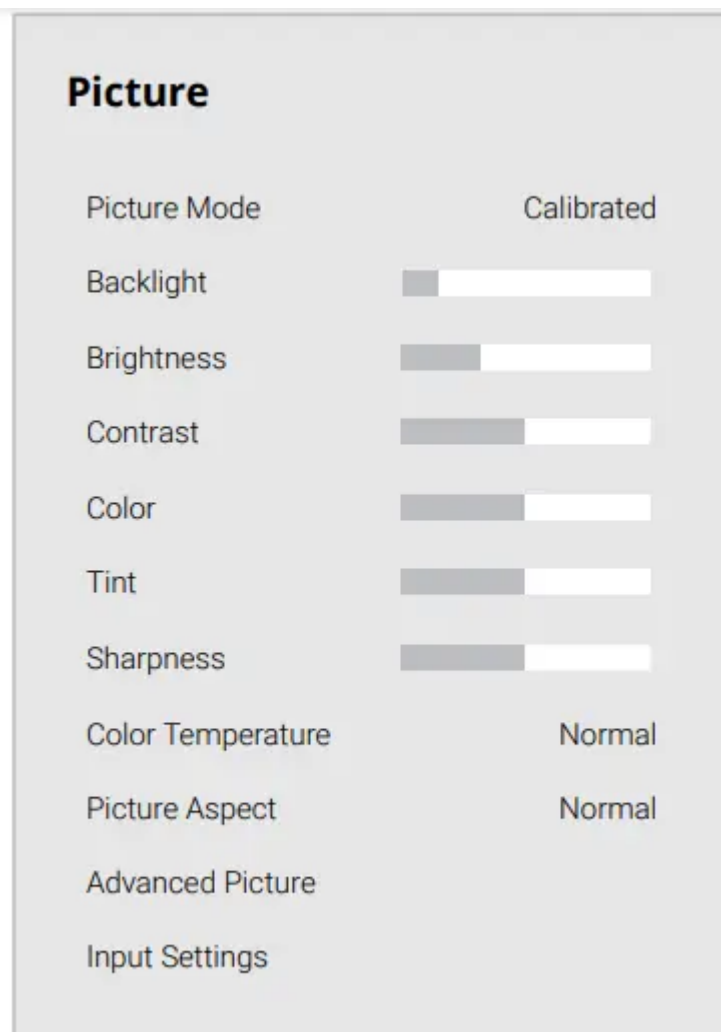

Adjusting the Color Temperature

Adjusting the color temperature changes the white balance of the picture.

To adjust the color temperature:

Menu > Picture > Color Temperature

Use the Navigation buttons on the remote to highlight a color temperature preset and then press OK.

- Warm — Produces an orange-hued picture.
- Cool — Produces a blue-hued picture.
- Normal — Optimized for television viewing.

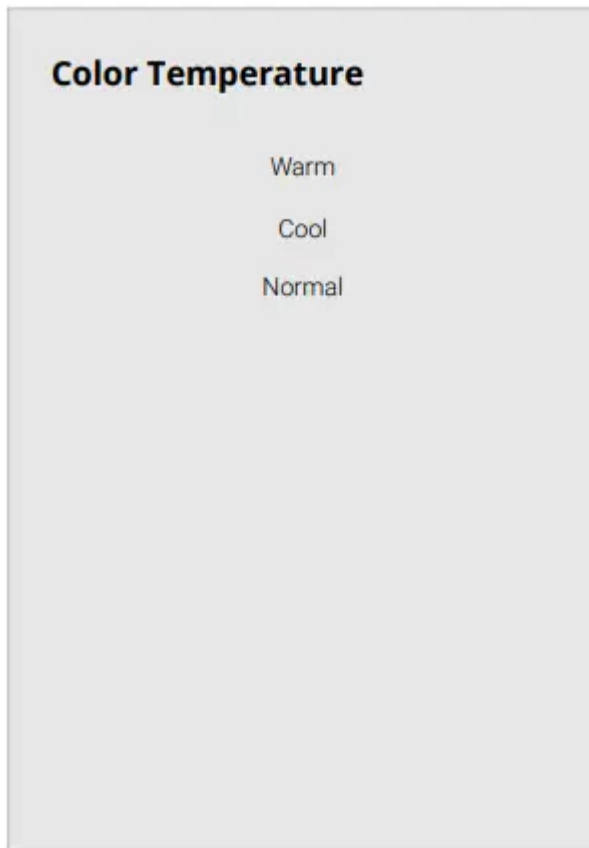

Changing the Picture Aspect Ratio

To change the screen aspect ratio:

Menu > Picture > Picture Aspect

Use the Navigation buttons to highlight the aspect ratio you wish to view.

Your TV can display images in different modes: Normal, Panoramic, Wide, Zoom, and Stretch.

- Normal (default) — No change to aspect ratio.
- Panoramic* — Stretches a 4:3 image to fill 16:9 screen with an algorithm so the center doesn't look stretched.
- Wide — Stretches a 4:3 aspect ratio to fill 16:9 screen. If a 16:9 image, adds black bars to top and bottom.
- Zoom — Expands image both horizontally and vertically by 14%.
- Stretch* — When the 16:9 signal is a 4:3 image with black bars left and right, stretches to fill the screen.

Some programs have black bars on the top or sides of the screen so that the picture keeps its original shape. Examples include widescreen movies and older TV programs

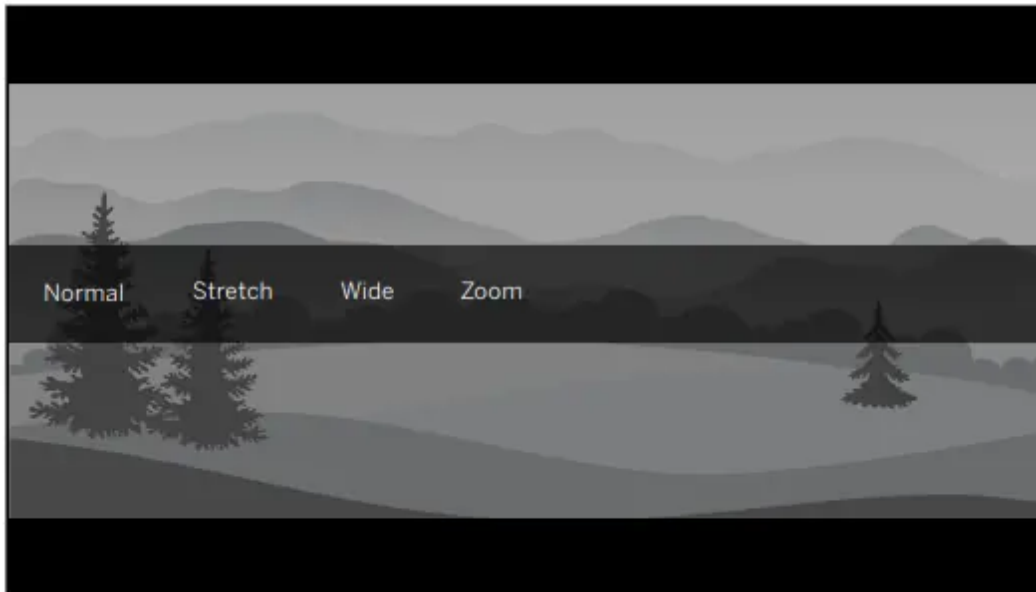

Adjusting Advanced Picture Settings

To adjust advanced picture settings:

Menu > Picture > Advanced Picture

Use the Navigation buttons to highlight the setting you wish to adjust, then press the Left/Right Navigation buttons to change the setting:

- **Black Detail** — Adjusts the average brightness of the picture to compensate for large areas of brightness.
- **Super Resolution** — Configures the resolution to enhance dim and blurred pictures resulting in a sharper image.
- **Edge Enhancement** — Increases the smoothness of edges.
- **Local Contrast** — Adjust the contrast of the picture locally.
- **Backlight Control** — Dynamically improves the contrast ratio of the picture by adjusting the backlight.
- **Reduce Noise:**
 - **Signal Noise:** Reduces background picture noise when viewing analog sources. This function helps to correct "speckle" noise with a slight reduction in sharpness.
 - **Block Noise:** Reduces the side effects of digital compression such as "blocking" and noise on sharp edges. The High setting will cause a slight reduction in sharpness.
 - **Contour Smoothing:** Removes visible contour noise without loss of the complex detail.

- Game Low Latency — Reduces video delay (lag) when gaming. When set to Auto and Automatic Low Latency Mode (ALLM) is detected, ALLM will apply for the duration of the game.
- Film Mode — Optimizes the picture for watching films. Select On or Off.
- Gamma — Set the shape of the Gamma curve. Use lower Gamma values for bright room conditions, and higher values when it's dark.
- Color Calibration — Calibrate colors using HSB, gain, offset and 20 point white balance and test or reset colors to defaults.

Advanced Picture	
Black Detail	Off
Super Resolution	Medium
Edge Enhancement	Low
Local Contrast	Low
Backlight Control	On
Reduce Noise	
Game Low Latency	Auto
Film Mode	On
Gamma	2.1 - Normal
Color Calibration	

Adjusting the Color Tuner Settings

The Color Tuner settings allow you to adjust the color management system, 20 point white balance, turn color channels off for testing, and display SMPTE, flat, ramp, and uniformity analyzer test patterns.

To access the color tuner table:

Menu > Picture > Advanced Picture > Color Calibration > Color Tuner

To turn color channels off and on:

1. Use the Navigation buttons on the remote to highlight Red, Green, or Blue.
2. Press the OK button to turn the color channel off or on. An X appears over a color channel that has been turned off.
3. Only two color channels can be turned off at the same time.

To adjust the color management system/20 point white balance settings:

1. Use the Navigation buttons on the remote to highlight the Hue, Saturation, Brightness, Offset, or Gain of the color you wish to adjust. Press the OK button.
2. Use the Left/Right Navigation buttons to adjust the value. When you are finished press the OK button to save the setting.

Color Tuner						
	Red	Green	Blue	Cyan	Magenta	Yellow
Hue	0	0	0	0	25	-14
Saturation	-1	5	-4	0	-2	0
Brightness	-24	0	-22	0	0	0
Offset	0	0	0			
Gain	0	0	0			

To adjust the 20 Point White Balance settings:

3. From the Color Tuner table, use the Navigation buttons to highlight the top bar and then press the Left/Right Navigation buttons until the 20 POINT WHITE BALANCE menu is displayed.

20 Point White Balance				
	Gain	Red	Green	Blue
	5%	0	0	0

4. Use the Navigation buttons on the remote to highlight the Gain and Color values you wish to adjust. Press the OK button and use the Left/Right Navigation buttons to adjust the value. When you are finished, press the OK button to save the setting.

To show or hide the SMPTE Test Pattern:

Menu > Picture > Advanced Picture > Color Calibration > Color Tuner > SMPTE Test Pattern

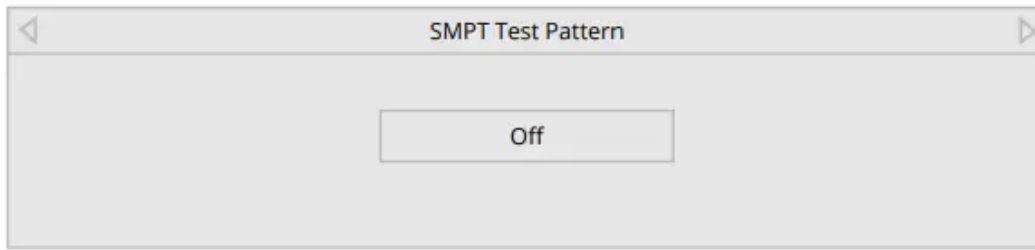

1. Use the Navigation buttons on the remote to highlight Off. Use the Left/Right Navigation buttons to select On to show the SMPTE Pattern.

—or—

2. To hide the SMPTE Test Pattern, use the Left/Right Navigation buttons to select Off.

To show or hide the Flat Test Pattern:

Menu > Picture > Advanced Picture > Color Calibration > Color Tuner > Flat Test Pattern

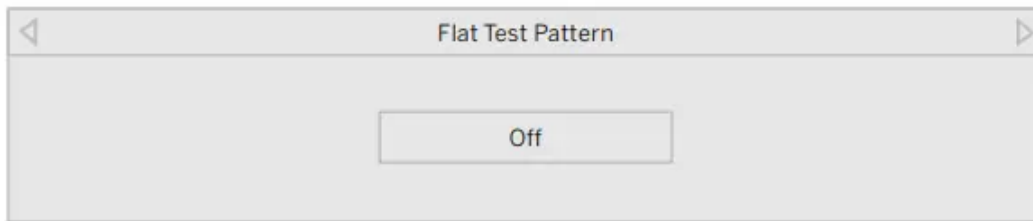

1. Use the Navigation buttons on the remote to highlight Off. Use the Left/Right Navigation buttons to select the percentage brightness for the flat test pattern. Selecting a percentage immediately shows the flat pattern at that brightness.

or

2. To disable the Flat Test Pattern, use the Left/Right Navigation buttons to select Off

To show or hide the Ramp Test Pattern:

Menu > Picture > Advanced Picture > Color Calibration > Color Tuner > Ramp Test Pattern

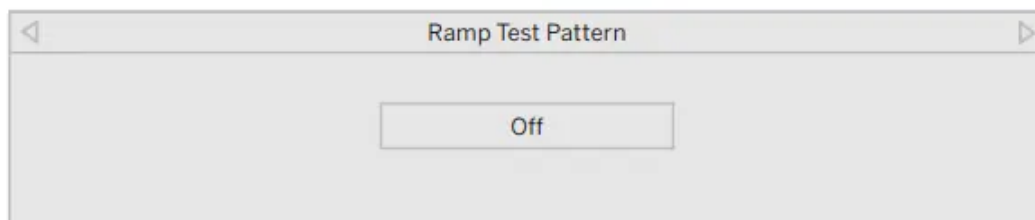

1. Use the Navigation buttons on the remote to highlight Off. Use the Left/Right Navigation buttons to select the color for the ramp test pattern. Selecting a color immediately shows that color ramp.

—or—

2. To hide the Ramp Test Pattern, use the Left/Right Navigation buttons to select Off.

To show or hide the Uniformity Analyzer Test Pattern:

Menu > Picture > Advanced Picture > Color Calibration > Color Tuner > Uniformity Analyzer Test Pattern

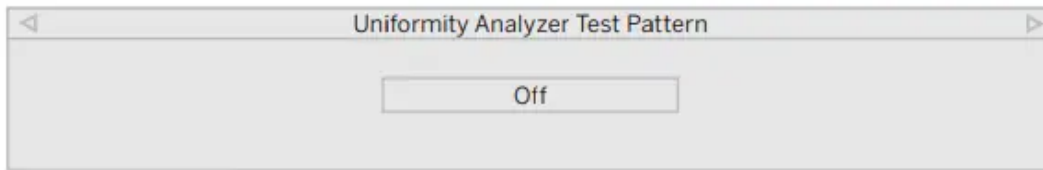

1. Use the Navigation buttons on the remote to highlight Off. Use the Left/Right Navigation buttons to select On to show the Uniformity Analyzer Test Pattern.

—or—

2. To hide the Uniformity Analyzer Test Pattern, use the Left/Right Navigation buttons to select Off.

ADJUSTING THE NETWORK SETTINGS

Your TV is Internet-ready, featuring both an Ethernet port and built-in high-speed wireless internet.

Connecting to a Wireless Network

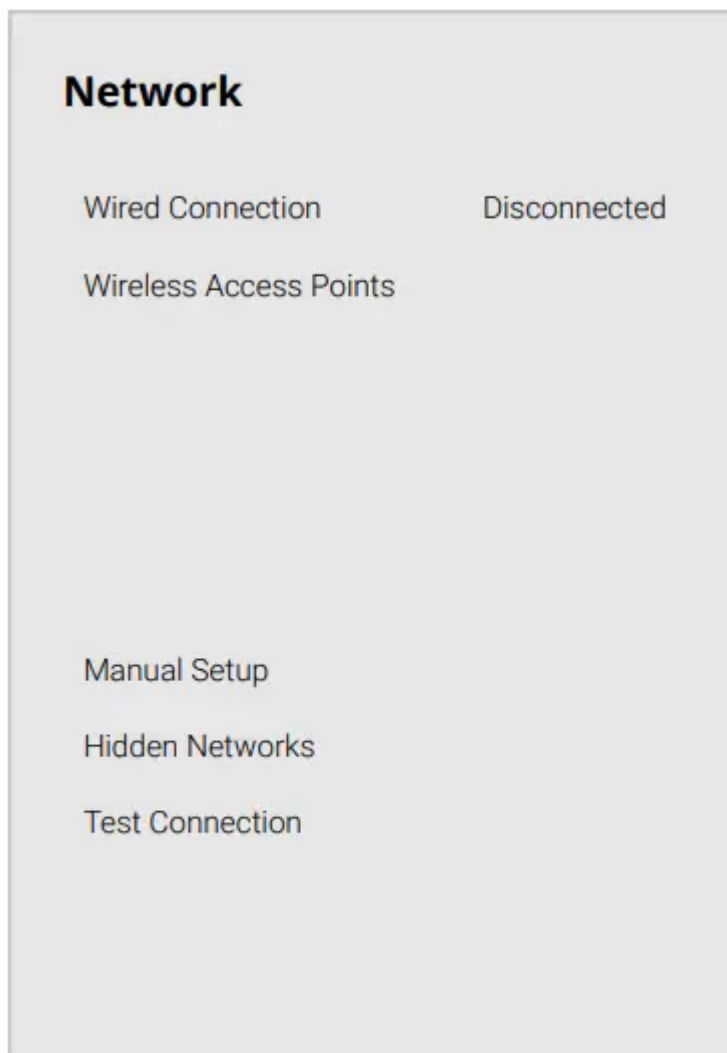

To connect to a wireless network whose network name (SSID) is being broadcast:

Menu > Network > Choose your network > Enter in the password > Connect

To forget a saved network:

Highlight a saved wireless access point > OK > Forget

If you do not see your wireless network displayed, click on:

More Access Points > Highlight your wireless network > Enter in the password > Connect

Changing the Manual Setup Settings

Advanced users can fine-tune the network settings using the Manual Setup feature. The security settings on your router may require you to enter the TV's MAC address.

To change advanced network settings:

Manual Setup

DHCP	Off
IP Address	— — — — —
Subnet Mask	— — — — —
Default Gateway	— — — — —
Pref. DNS Server	— — — — —
Alt DNS Server	— — — — —
RJ45 Mac	0:0:0:0:0:0
Wireless Mac	0:0:0:0:0:0

Menu > Network > Manual Setup > DHCP > Off

- Use the Navigation and OK buttons to adjust each setting:
 - IP Address — The IP address assigned to the TV.
 - Subnet Mask — The subnet Exit 2D.
 - Default Gateway — Your network’s default gateway address.
 - Pref . DNS Server — Your preferred domain name server address.
 - Alt . DNS Server — Your alternate domain name server address.
- Use the Navigation buttons on the remote to highlight Save and press OK.

To find the TV’s MAC address:

Menu > Network > Manual Setup

can find your TV's MAC address at the bottom of the list. The MAC addresses for the connections in use are displayed:



- RJ45 MAC — The Ethernet or RJ45 MAC address may be needed to set up your network when you have connected the TV to your network with an Ethernet (Cat 5) cable.
- Wireless MAC — The Wireless (Wi-Fi) MAC address may be needed to connect your TV to your network with Wi-Fi.

Connecting to a Hidden Network

To connect to a wireless network whose network name (SSID) is not being broadcast:

Menu > Network > Hidden Network > Enter the Access Point Name > Connect > Enter in the password

Testing Your Network Connection

To test your network connection:

Menu > Network > Test Connection

Enter Access Point Name

Enter your access point name. This is used to connect to an access point with a hidden SSID.

— [X]

a	b	c	d	e	f	g	h	i
j	k	l	m	n	o	p	q	r
s	t	u	v	w	x	y	z	0
1	2	3	4	5	6	7	8	9
.@#	↑	äêí	Space	[X]				

SETTING UP TV CHANNELS

You can use the TV's Channels menu to:

- Find channels
- Find new channels
- Select channels to skip

- Select analog audio mode
- Select the language for digital audio
- Set parental controls

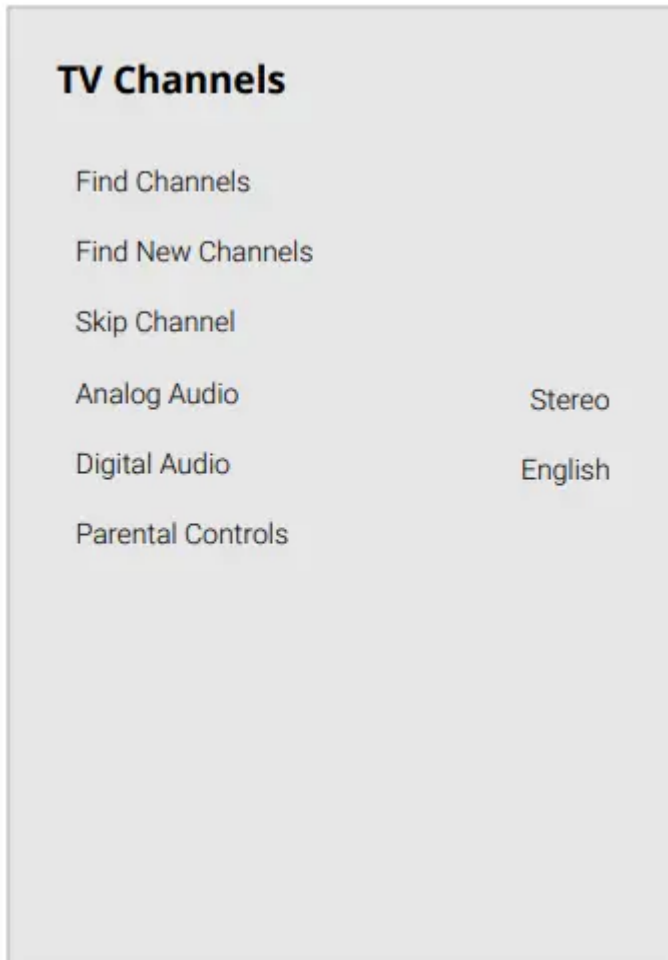

Scanning for TV Channels

The TV may need to scan for channels before it can display programs and their associated information. A channel scan is required for free over-the-air channels (using an antenna) and cable channels from an out-of-the-wall connection (without a cable box). Moving the TV to an area with different channels requires the TV to scan for channels again.

To perform an Auto Channel Scan:

Menu > TV Channels > Find Channels

Wait until the channel scan is 100% complete. Highlight Done and press OK.

- If the channel scan is canceled, the channels that were already discovered are retained.

To perform a New Channel Scan:

Menu > TV Channels > Find New Channels

A New Channel Scan saves the current channel map and scans for additional channels.

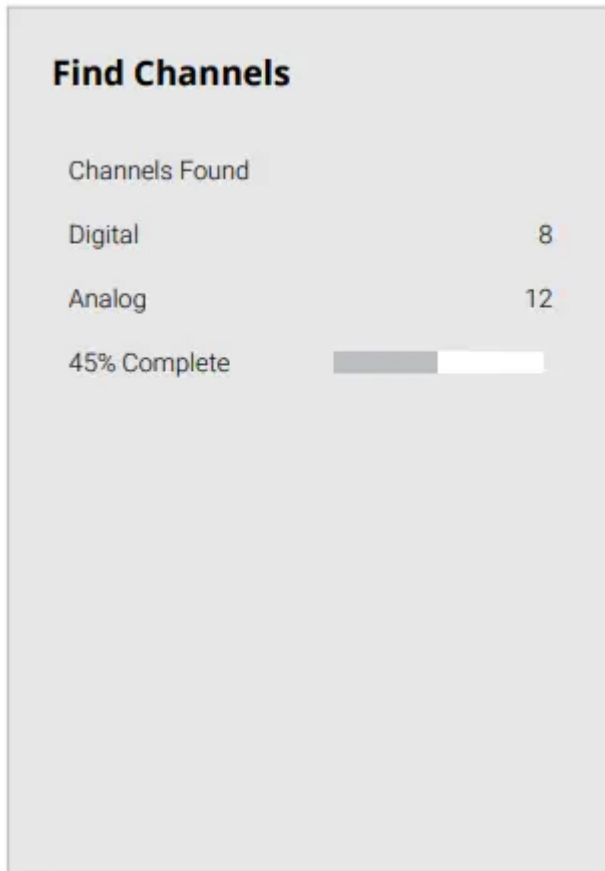

Skipping Channels

After a channel scan is completed, you may find that some channels are too weak to watch comfortably. There may also be some channels you do not want to view. You can remove these channels from the TV's memory with the Skip Channel feature.

To remove a channel:

1. From the TV CHANNELS menu, highlight Skip Channel, and press OK. The SKIP CHANNEL menu is displayed.
2. For each channel you wish to remove, use the Up/Down Navigation buttons on the remote to highlight the channel and press OK. A ✓ appears to the right of each channel you select.

Skip Channel

0	Test 0	<input type="checkbox"/>
1	Test 1	<input type="checkbox"/>
2	Test 2	<input type="checkbox"/>
3	Test 3	<input type="checkbox"/>
4	Test 4	<input type="checkbox"/>

Changing the Analog Audio Language

Some analog over-the-air (free) and cable channels broadcast programs in more than one language. The TV's Analog Audio feature allows you to listen to audio in an alternate language using Secondary Audio Programming (SAP).

To use the Analog Audio feature:

Menu > TV Channels > Analog Audio

- Stereo — More than one speaker channel is being used. Sounds may be dispersed through different speakers depending on how the audio is programmed.
- SAP (Secondary Audio Program) — Typically used for audio in a different language other than the native one used in the program.
- Mono — All speakers are producing the same sound; there is no distinction between left or right sounds.

Analog Audio

Stereo

SAP

Mono

To use the Digital Language feature:

Menu > TV Channels > Digital Audio

Select the preferred audio language. Available languages or video descriptions depend on the broadcast content.

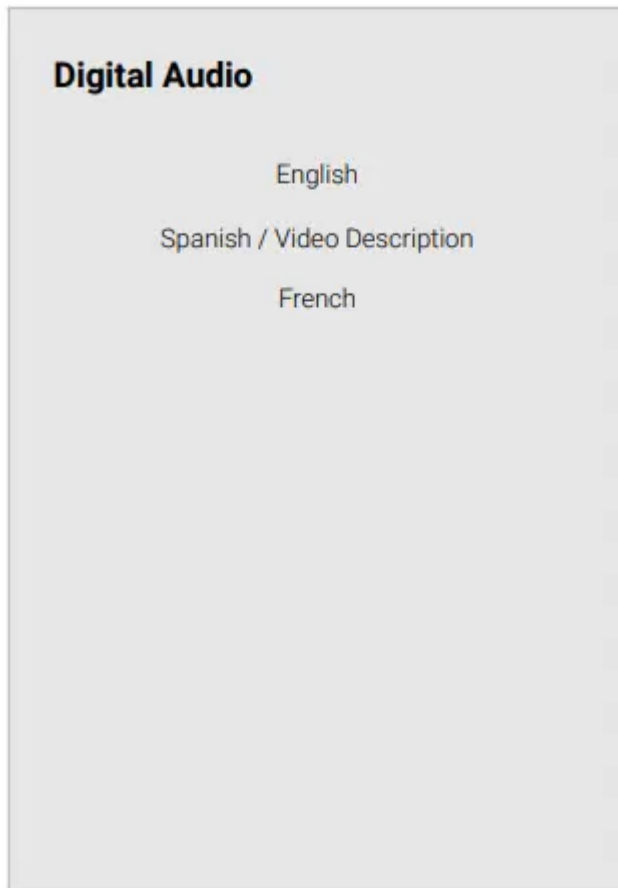

Using Parental Controls

The TV's parental controls allow you to prevent the TV from displaying certain channels or programs unless a PIN is used.

Accessing the Parental Controls Menu

To access the Parental Controls menu you must first set up a system PIN:

Menu > TV Channels > Parental Controls > Enter in PIN

The Parental Controls menu only appears when:

- You are using the tuner to receive your TV signals, such as when you are using an antenna for Over-the-Air signals or when connected to cable TV directly from the wall (no cable box).
- You have a device connected using a composite video cable or a coaxial cable, such as a VCR, satellite or cable box, or DVR

Enabling or Disabling Program Ratings

To manage program content according to its rating, you must first enable the Program Rating feature.

To enable or disable the Program Rating feature:

Menu > TV Channels > Parental Controls > Locks > Off/On

Locking and Unlocking Channels

When a channel is locked, it cannot be accessed. Locking a channel is a good way to prevent children from viewing inappropriate material.

To lock or unlock a channel:

Menu > TV Channels > Parental Controls > Channel Locks

Highlight the channel you want to lock or unlock and press OK.

- When a channel is locked, the Lock icon appears  locked. The channel is not accessible unless the system PIN is entered.

- When a channel is unlocked, the Lock icon appears  unlocked.

Blocking and Unblocking Content by Rating

A channel may sometimes broadcast programs that are meant for a variety of audiences (some for children and some for adults). You might not want to block the channel completely using a channel lock, but you can block certain programs from being viewed.

You can use the TV's Rating Block feature to block content based on its rating.

To block or unblock content by its rating:

1. From the Parental Controls menu, highlight the content type you want to adjust and press OK:

- USA TV — USA television program broadcasts.
- USA Movie — USA movie broadcasts.
- Canadian English — Canadian English television program broadcasts.
- Canadian French — Canadian French television program broadcasts.

2. For each rating type you want to block or unblock, use the Navigation buttons to highlight the rating type and press OK.

- When the rating type is blocked, the Lock icon appears  locked. Content with this rating and all higher ratings cannot be viewed.

- When the rating type is unblocked, the Lock icon appears  unlocked. Content with this rating and all lower ratings can be viewed.

- If you want to block all unrated content, highlight Block Unrated Shows and use the Navigation buttons on the remote to select On.

ACCESSIBILITY SETTING

VIZIO is committed to providing intuitive, user-friendly products. Your new VIZIO TV offers several accessibility features that can help you with easy navigation.

To access the Accessibility menu:

Menu > Accessibility

1. Captions — Activate and customize analog and digital closed captions.
2. Video Description — If included by the broadcaster, provides a narrated description of the action for the content.
3. Talk Back* — Enables your TV to speak all settings changes and adjustments using the remote in English.
4. Speech Rate — Adjusts the rate in which Text-to-Speech is spoken. Select Slow, Normal (default), or Fast.
5. Zoom Mode — Enlarges a section of the screen by approximately 200%.

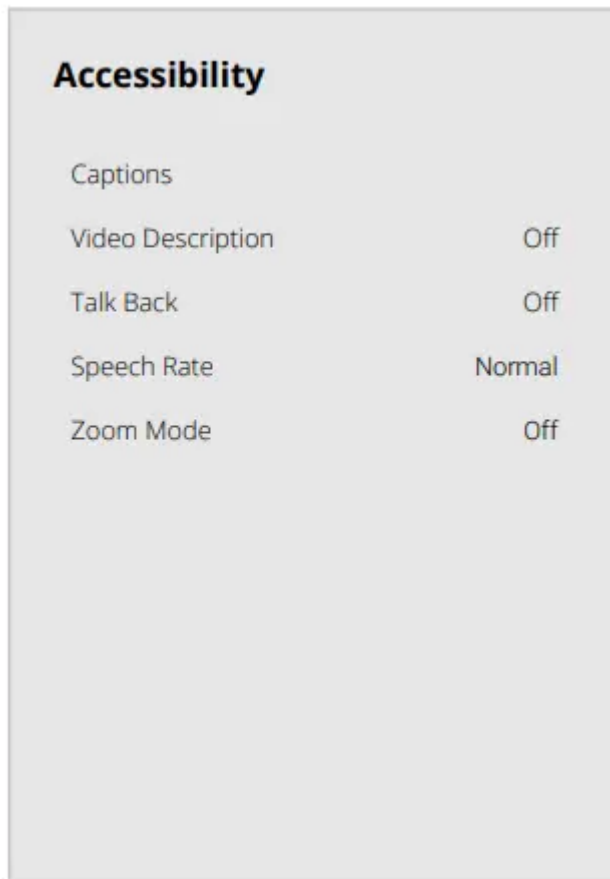

Setting Up Closed Captioning

Your TV can display closed captions for programs that include them. Closed captions display a transcription of a program's dialogue.

To activate or deactivate Close Captions for current content:

Menu > Accessibility > Captions > Closed Captions > Off/On

— or —

Push the **CC** button on the remote .

1. Use the Navigation buttons on the remote to highlight either Analog or Digital Closed Captions.
2. Use the Left/Right Navigation buttons on the remote to select the caption channel you wish to display

Closed Captions

Closed Captions	Off
Analog Closed Captions	CC1
Digital Closed Captions	CS1
Digital Style	

Changing the Appearance of Digital Closed Captions

Digital closed captions can be displayed according to your preference. See the diagram on the next page for an explanation of the parts of the closed caption area.

To change the appearance of digital closed captions:

Menu > Accessibility > Captions > Digital Style

1. Use the Left/Right Navigation buttons on the remote to select Custom. The Digital Style menu appears as shown
2. Use the Up/Down Navigation buttons on the remote to highlight the setting you wish to change, then use the Left/Right Navigation buttons to change the settings (choose "As Broadcast" to keep default setting):
 - Text Style — Change the font used for the closed captioning text.
 - Text Size — Make the text larger or smaller.
 - Text Color — Change the color of the text.

- Text Opacity — Change the transparency of the text.
- Text Edges — Change the effects at the edges of the text, such as raising the edges or adding drop shadows.
- Text Edges Color — Change the color of the text edge effects.
- Background Color — Change the color of the background directly behind the text.
- Background Opacity — Change the transparency of the background directly behind the text.
- Window Color — Change the color of the closed captioning box.
- Window Opacity — Change the opacity of the closed captioning box.

Digital Style	
Text Style	As Broadcast
Text Size	Large
Text Color	Blue
Text Opacity	As Broadcast
Text Edges	As Broadcast
Text Edges Color	As Broadcast
Background Color	As Broadcast
Background Opacity	As Broadcast
Window Color	As Broadcast
Window Opacity	As Broadcast

Typical choices include:

- Opaque background, transparent window — Only a strip of background appears behind the text, expanding as the text appears. This is the typical "As Broadcast" mode.
- Opaque background and window in the same color — When text appears, the entire line fills with color at once.

In the example, the closed caption text is green, the background is black, and the window is red.

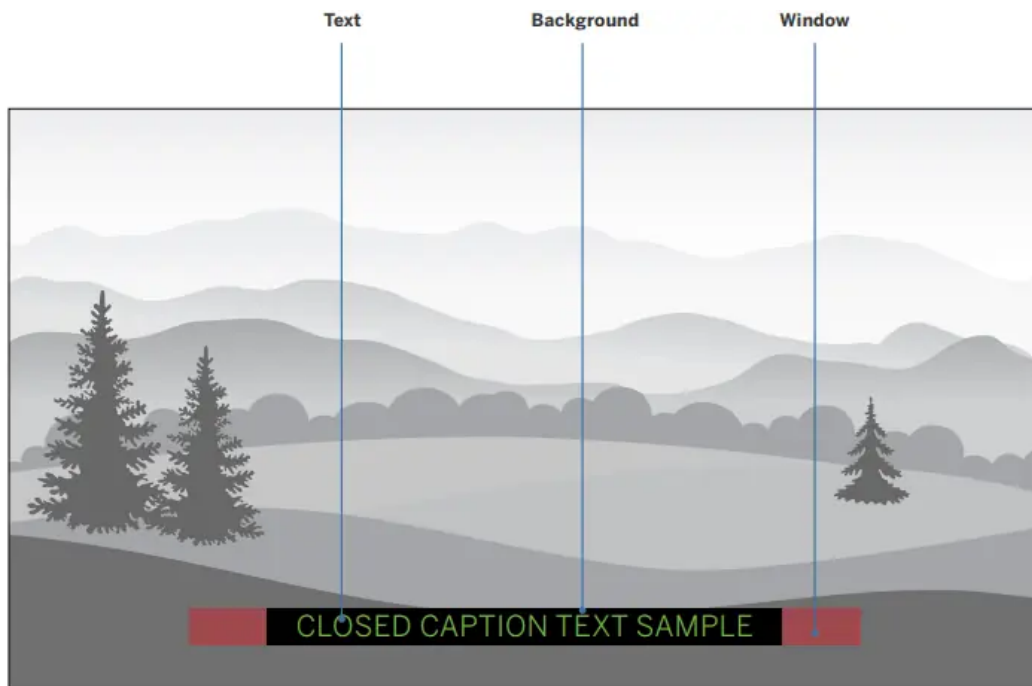

CHANGING THE SYSTEM SETTINGS

Using the System menu, you can:

- Change the on-screen menu language
- Set the time zone and local settings
- Name the TV
- Name an input
- Hide inputs not in use
- Adjust the power mode settings
- Set the USB power mode
- Turn the power indicator on or off
- Set up timers
- Set a system PIN code
- Adjust CEC settings
- Manage paired devices
- Manage a voice remote control

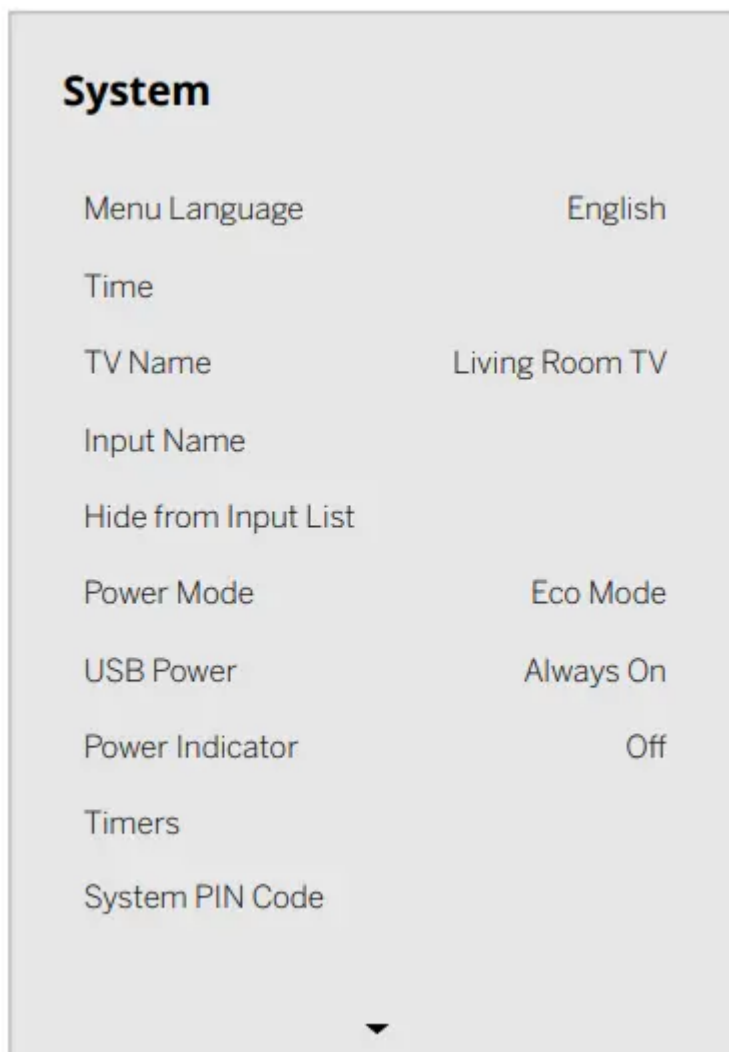

Changing the On-Screen Menu Language

Your TV can display the on-screen menu in different languages.

To change the on-screen menu language:

Menu > System > Menu Language

Highlight your preferred language (English, Español, or Français) and press OK.

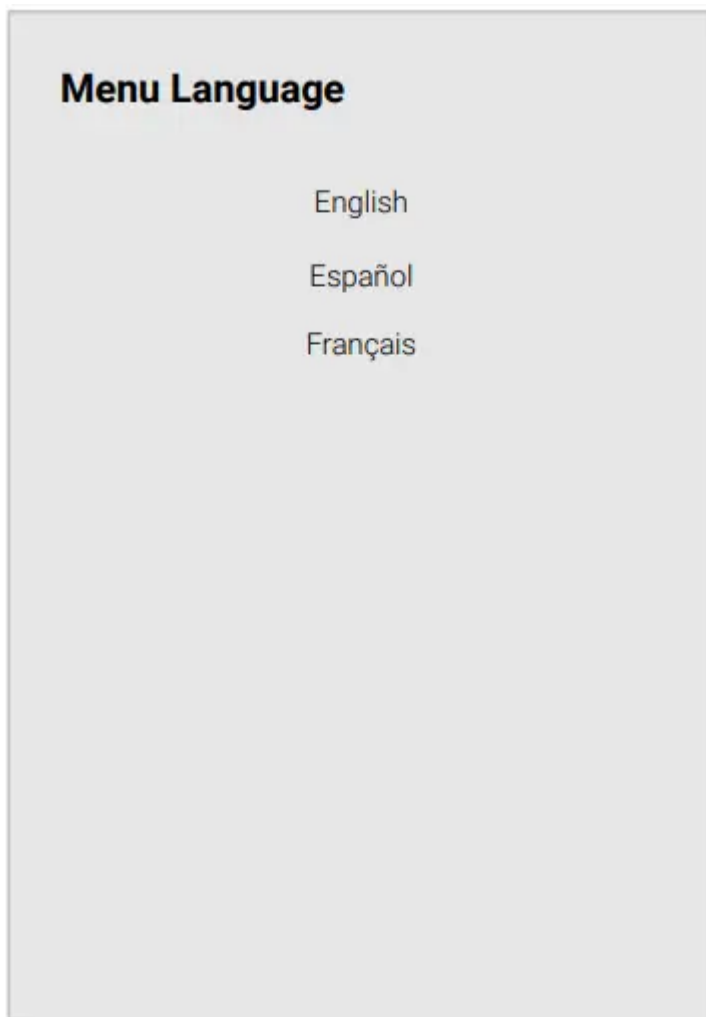

Setting the Time

To ensure the correct time is displayed when you press the INFO button, set the TV's time zone:

Menu > System > Time > Time Zone

To turn Daylight Saving Time on or off:

1. Highlight Daylight Saving Time and press OK. The Daylight Saving Time menu is displayed.
2. Choose On if it is currently Daylight Savings Time, Off if it is Standard Time, or Auto to have the system automatically detect Daylight Savings Settings.

To change Time Format:

1. Highlight Time Format and use the Left/Right Navigation buttons to change between a 12-hour format or 24-hour format.

Changing the TV Name

Naming your TV helps differentiate it from other cast devices you may have in your home.

To edit your TV name:

Menu > System > TV Name > Enter a Name

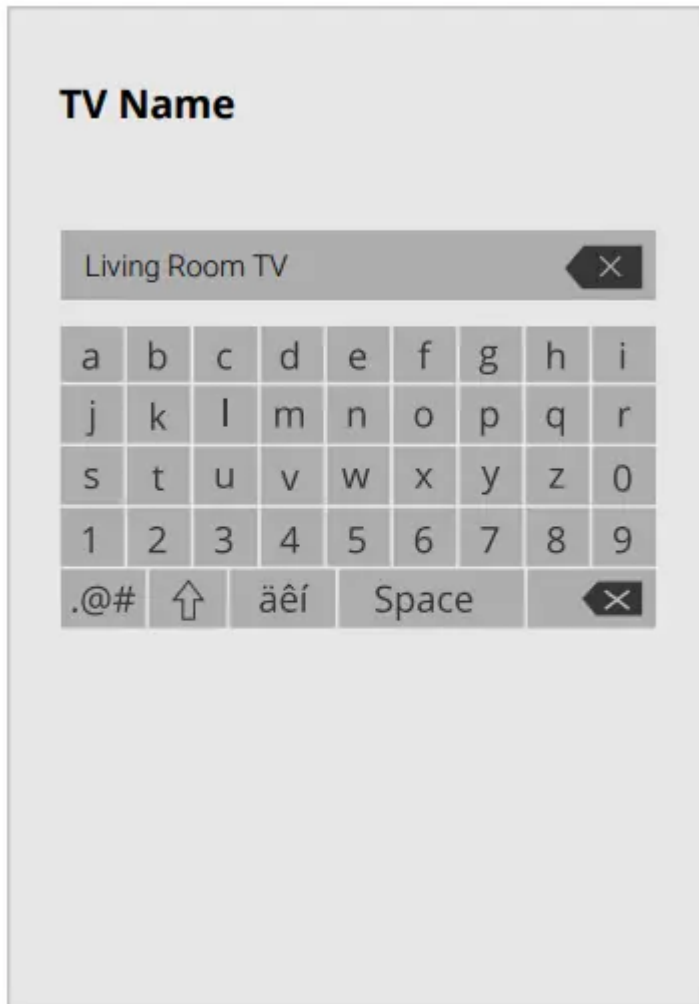

Renaming Devices on the Input Menu

You can rename the inputs to make them easier to recognize on the Input menu. For example, if you have a DVD player connected to the HDMI-1 input, you can rename that input to display “DVD Player.”

See Changing the Input Source on page 7.

To change the name of an input:

Menu > System > Input Name

To enter a custom name:

- Highlight the Name Input row and press OK.
- Enter your custom label using the on-screen keyboard and press OK.

To Hide an Input from the List:

Menu > System > Hide from Input List

- Highlight the input name you would like to hide. Hidden inputs will not be displayed in the input list.
- Use the Left/Right Navigation buttons to toggle from visible and hidden.

Adjusting the Power Mode

Your TV is set to Eco Mode by default. When the TV is powered off, the Eco Mode setting uses less than 0.5W of power. Quick Start Mode enables your display to power on faster and also to turn on when powered from another device (such as when you are casting onto the TV)

To switch between Eco Mode and Quick Start Mode:

Menu > System > Power Mode

Highlight either Eco Mode or Quick Start Mode and press OK.

Using the USB Power Feature

The USB port can be used to charge devices.

The two options for this feature are:

- Always On — Power is always available.
- Off When TV Off — Power is only available with the TV is on.

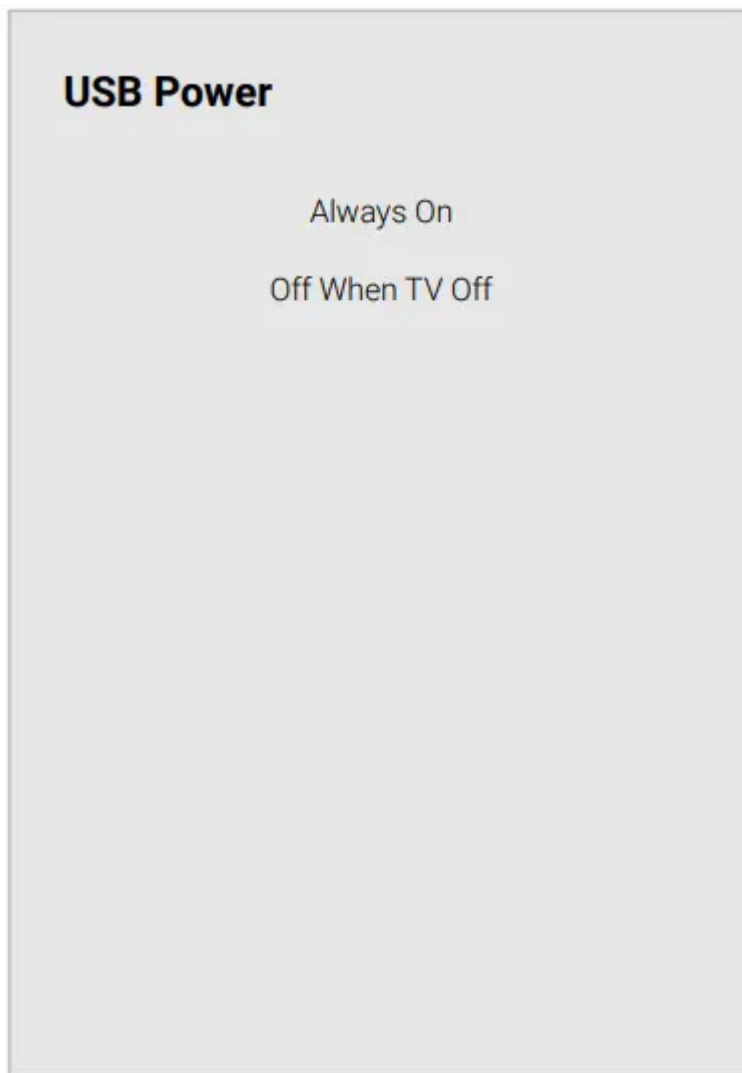

Turning the Power Indicator On or Off

The power indicator on the front of your TV normally does not glow when the TV is on. You can change this setting if you prefer the light to be on.

To turn the Power Indicator Light On or Off:

Menu > System > Power Indicator > Off/On

Setting Timers

When activated, the TV's timer will turn the TV off after a set period of time.

To setup a sleep timer:

Menu > System > Timers > Sleep Timer

Use the Left/Right Navigation buttons on the remote to highlight the period of time after which you want the TV to go to sleep: 30, 60, 90, 120, or 180 minutes. If you don't want the sleep timer to activate, change the setting to Off.

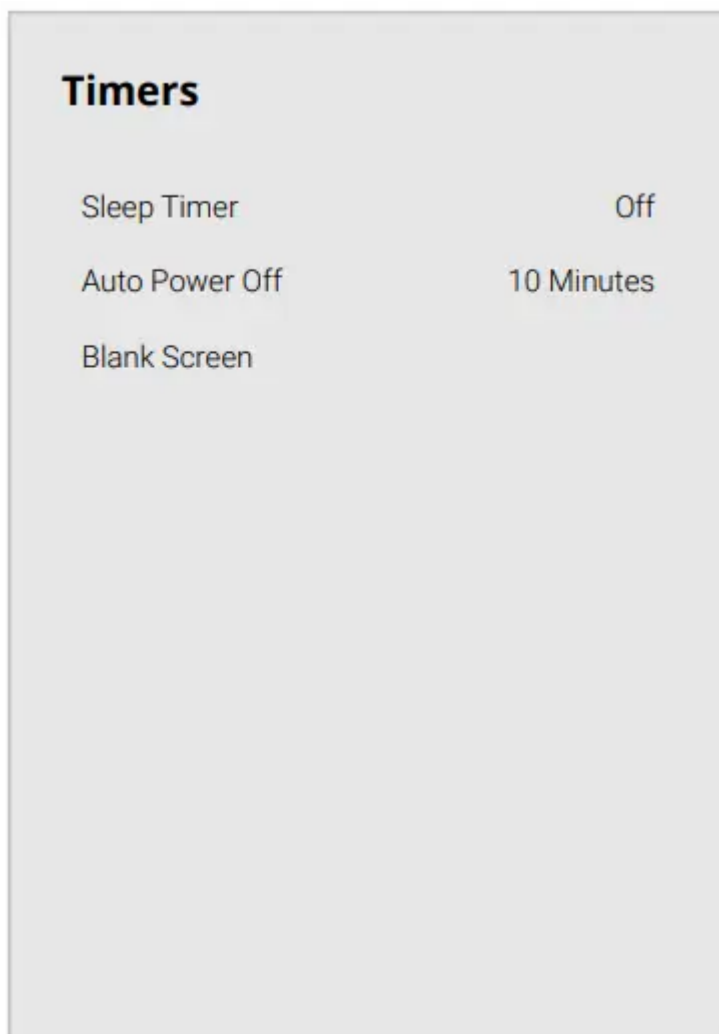

Setting the Auto Power Off Feature

To help save energy, your TV is set by default to turn off after 10 minutes without a video or audio signal. This feature can be deactivated.

To set the Auto Power Off feature:

Menu > System > Timers > Auto Power Off > Off

Using the Blank Screen Feature

To help save LED life, your TV screen can turn on or off while audio is streaming.

To use the Blank Screen feature:

Menu > System > Timers > Blank Screen

To exit Blank Screen, press any key (except the volume and mute keys)

Setting a System PIN Code

You can set a system pin to lock content and picture modes, as well as prevent accidental system resets. The first time you select System PIN code, you will need to create a PIN.

To create a PIN:

Menu > System > System PIN Code > Enter Your PIN > Save

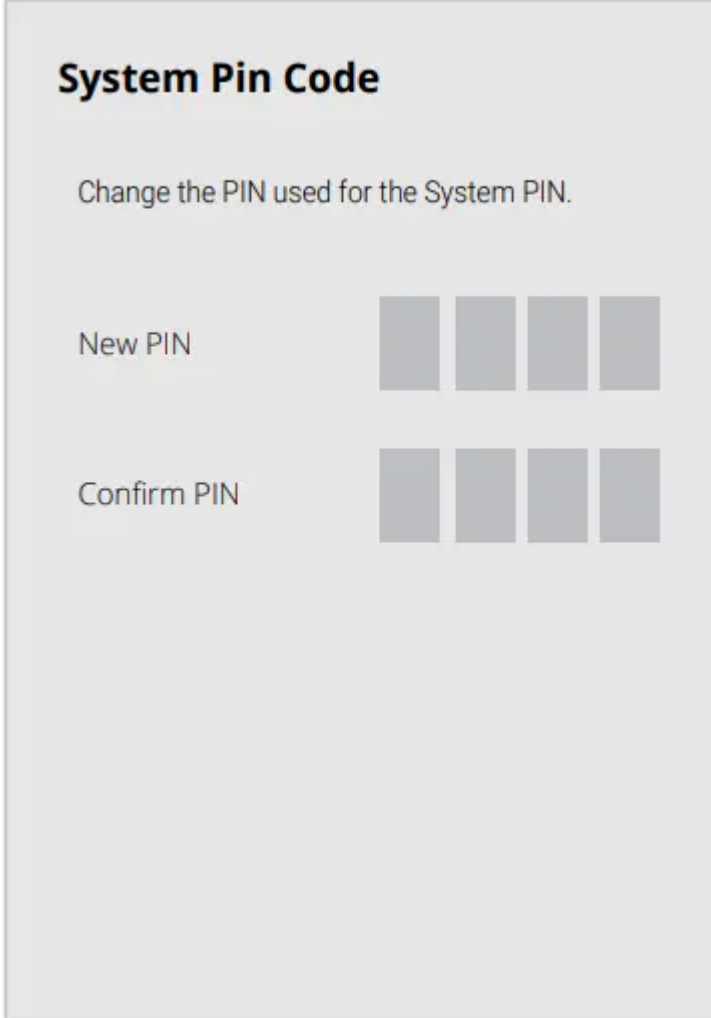

System Pin Code

Change the PIN used for the System PIN.

New PIN [] [] [] []

Confirm PIN [] [] [] []

Adjusting the CEC Settings

The CEC function on your TV enables you to control devices connected to an HDMI input with the VIZIO TV remote, without any programming

Menu > System > CEC

Select a setting and then press OK.

- CEC — To use CEC, you must select Enable.
- Device Discovery — To determine if your device is connected and supports CEC, select Device Discovery and then press OK .

CEC Audio Setup

Connect your audio device to the HDMI-1 (HDMI ARC) input on the TV. On your audio device, select the HDMI ARC input.

Using CEC, your VIZIO TV remote can control such features including (depending on specific device):

- Power On/Off
- Volume and mute
- Play and pause

Managing Mobile Devices

Your TV can be paired with a mobile device so you can easily control your TV across multiple devices.

To see a list of paired devices or unpair a device:

Menu > System > Mobile Devices

Highlight a device name to delete it and press OK.

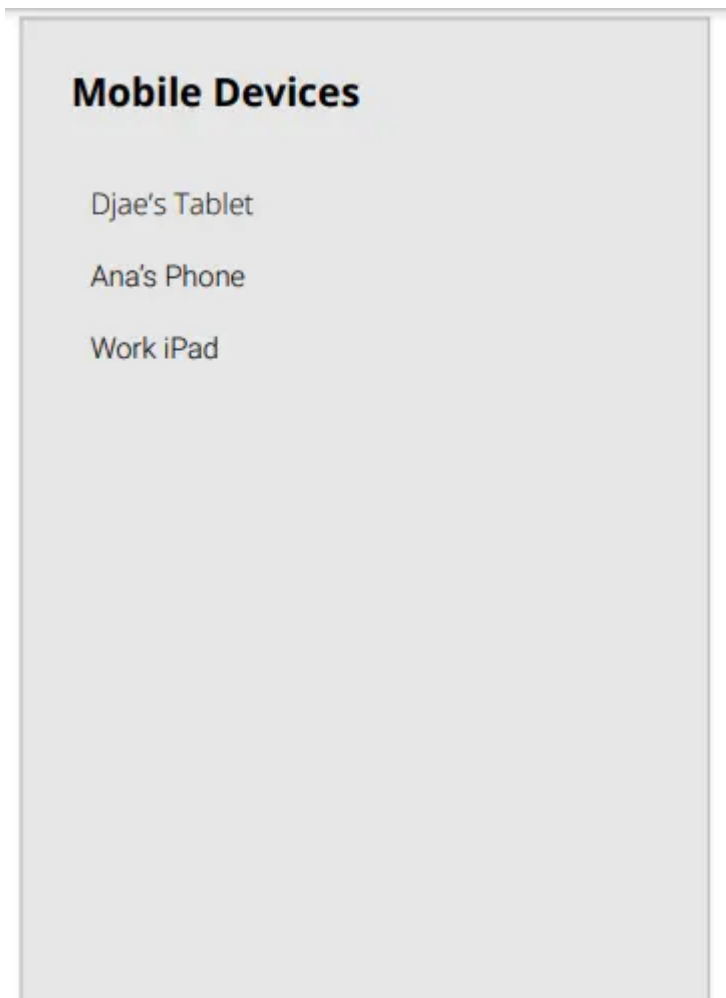

USING THE ADMIN & PRIVACY MENU

You can use the TV's Admin & Privacy menu to restore the TV to its factory default settings as well as access other administrative settings.

Using the ADMIN & PRIVACY menu, you can:

- View system information
- Check for system updates
- Force the system to power off and on
- Reset the TV to factory settings
- Enable or disable store demo
- Enable or disable viewing data
- Personalize advertising choices
- View the VIZIO Privacy Policy
- Start or stop the store demo mode

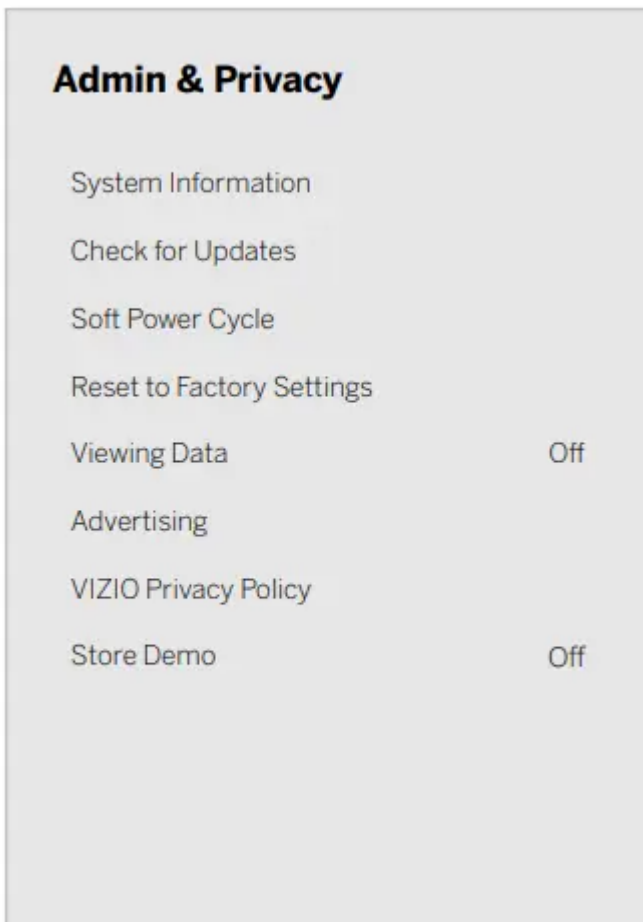

Viewing System Information

To view technical data and status information about your TV and network connection:



Menu > Admin & Privacy > System Information

Checking for System Updates

To check for a system update:

Menu > Admin & Privacy > Check for Updates

If an update is found, the TV will ask to confirm the update. If no update is found, the screen will note The TV is up-to-date.

Performing a Soft Power Cycle

A soft power cycle forces the TV to turn off then on again.

Menu > Admin & Privacy > Soft Power Cycle > OK

Restoring the TV to Factory Default Settings

All of the on-screen menu settings can be reset to the factory defaults.

To restore the TV to its factory default settings:

Menu > Admin & Privacy > Reset to Factory Settings

1. If you set a system PIN code, enter it now.
2. The TV displays, "Select Reset to restore all TV settings to factory defaults."
3. Highlight Reset and press OK.
4. Wait for the TV to turn off. The TV will turn back on shortly afterward and the setup process will begin.

Store Demo

To set to Off, Demo 1, or Demo 2:

Menu > Admin & Privacy > Store Demo

USING THE INFO WINDOW

Press the INFO button to display:

- TV name
- Current input or for tuner: current channel
- Picture aspect
- Audio type
- Network name
- Time

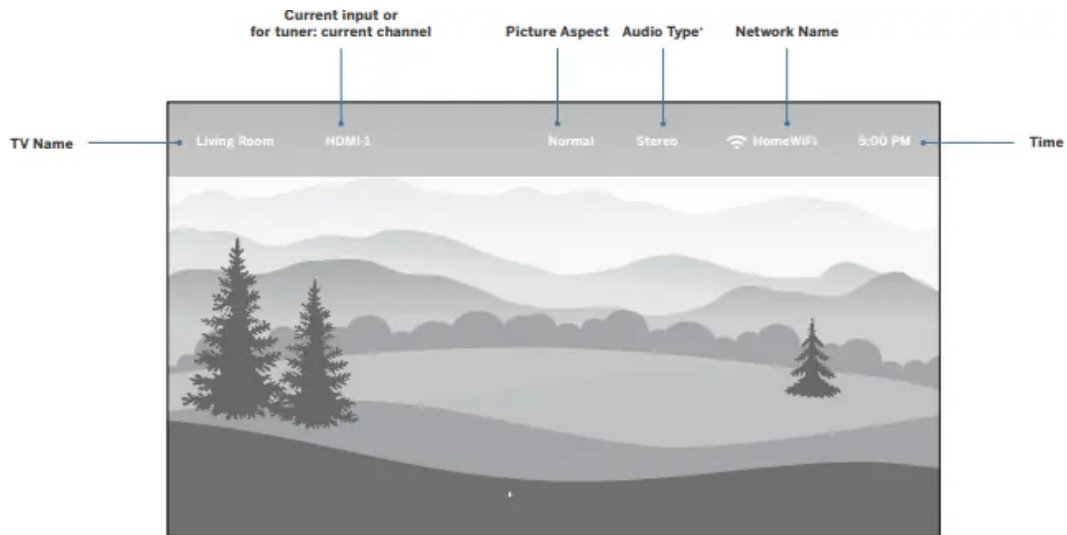

SmartCast Home™

What is SmartCast Home?

SmartCast Home lets you discover, stream, and control your content like never before! Access top apps, like Netflix, Hulu, and Amazon Prime Video, by using the remote to easily browse and launch content directly from the home screen. SmartCast Home makes finding something to watch easy and fun

How to Launch SmartCast Home

Begin streaming with SmartCast Home by:

-

Press the SmartCast Home button



on your remote.

—or—

- Select SmartCast from the list of inputs.

What you can do with SmartCast Home

- Stream high-quality entertainment.
- Launch top-tier apps directly from the home screen.
- Unlock your photos and videos by mirroring your laptop or mobile device onto your TV.
- Rearrange apps on your home screen just the way you like it.
- Works with Google Assistant and other popular voice assistants.

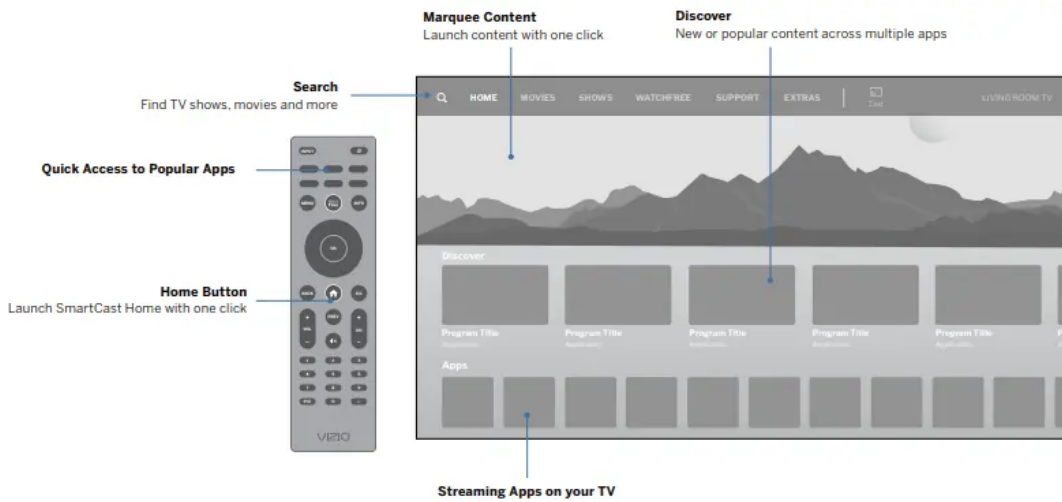

WatchFree™

What is WatchFree?

VIZIO WatchFree takes your cord-cutting entertainment experience one step further! With the simple press of a button, enjoy free streaming TV with over 100 live TV channels to choose from – news, movies, sports, comedy, music and more. A built-in on-screen guide makes finding something to watch easier than ever.

And it's all FREE —no fees, no subscriptions, or logins

What you can do with WatchFree

- Stream over 100 live TV channels absolutely free – news, movies, sports, comedy, music and more.
- Navigate through channels, organized by genre, with an intuitive on-screen guide.
- Watch 1000's of free movies from major studios.
- Watch the best of internet TV.
- No logins, subscriptions or transactions fees

How to Launch WatchFree

To launch and begin watching entertainment offered on WatchFree:

-

Press the WatchFree button  on your remote.

—or—

- Select WatchFree from the list of inputs.

Show Details
Find out show information

On-Screen Guide
Over 100 live TV and audio channels organized by genre

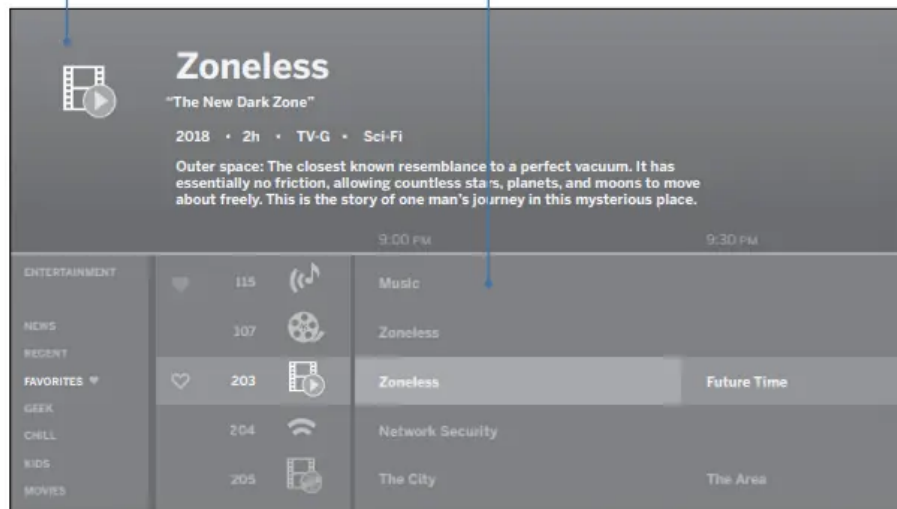

WatchFree Button

OK Button

Press the OK button to return to the WatchFree on-screen guide. Use the up/down Navigation buttons to scroll through the guide.

Playing USB Media

The USB Media Player allows you to connect a USB flash drive to your TV and play music, video, or photos.

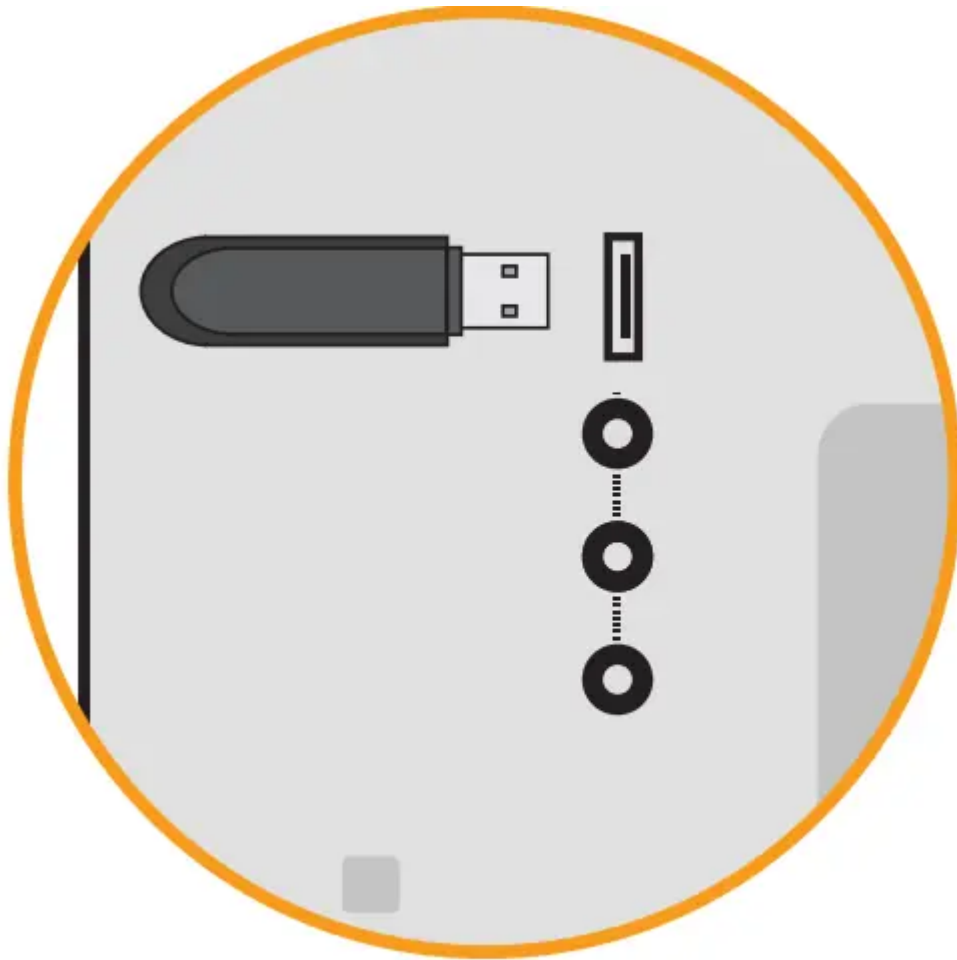

Preparing Your USB Drive to Play USB Media

To display USB media, you must first save your videos onto a USB flash drive:

- The USB flash drive must be formatted as FAT32.
- Files on the USB flash drive must end in a supported file extension (.mp3, .jpg, etc).
- The player is not designed to play media from external hard drives, MP3 players, cameras, or smartphones.

Displaying USB Media

To display your USB media:

1. Connect your USB flash drive to the USB port on the side of the TV.
2. The TV will recognize the USB. Use the Navigation Keys on the remote to select the content you want to play.

—or —

3. Select USB from the bottom streaming icons on the SmartCast Home™ page.

Removing the USB Drive from the TV

To safely remove your USB flash drive from the TV:

1. Turn the TV off.
2. Disconnect your USB flash drive from the USB port on the side of the TV

Playing USB Media: Music

Back Button
Highlight this button and press **OK** to return to the previous screen.

Now Playing Information
Displays song title, album title, and other information.

Progress Bar
Displays the duration of the currently-playing song. The bar will lengthen as the song progresses.

Album Art
If included on the USB thumb drive and associated with your music, the album art will display here.

Connected Sources
Displays connected USB devices.

Current Folder
My Music

Playback Control

Toggle Music/Photos
Browse Photos

Sort by Album/Artist/Track
Sort: Artist - A - Z
View: Folders

View All or View Folders
Toggle between viewing all content and only viewing folders.

Page Information
If your USB thumb drive has more files than can be displayed on a single screen, the page number is displayed here.

Folder Contents/Playlist
This area displays the contents of the currently selected folder. You can browse among files using the **Arrow** and **OK** buttons on the remote.

#	Track	Album	Artist	Duration
1	Starry Summer	Summer	JCheesy	2:42
2	Summer Nights	Summer	DJ Sunset	3:11
3	Mango Dreams	Beach Mix	Ana Banana	8:46
4	Crystal Waters	Beach Mix	The Dash	4:21
5	Smooth Waves	Breezy Mix	Rio Steve	7:58

Playing USB Media: Photo

Back Button
Highlight this button and press **OK** to return to the previous screen.

Connected Sources
Displays connected USB devices.

Current Folder
My Videos

Sort by Date or File Name
Sort: Date New-Old

View All or View Folders
Toggle between viewing all content and only viewing folders.

Play once or continuously
Play

Page Information
If your USB thumb drive has more files than can be displayed on a single screen, the page number is displayed here.

Folder Contents/Playlist
This area displays the contents of the currently selected folder. You can browse among files using the **Arrow** and **OK** buttons on the remote.

#	File	Date	Duration
1	Family Vacation - California	-	00:23:43
2	28th Birthday Party	-	00:38:28
3	Korea 2019	-	00:41:08
4	Sunny's Graduation	-	00:29:32

Help Topics

The remote is not responding .

- Make sure the batteries are properly inserted matching the - and + symbols.
- Replace the batteries with fresh ones.

The TV displays “No Signal .”

- Press INPUT button on the remote control to select a different input source.
- If you are using cable TV or antenna connected directly to the TV, scan for channels. See Scanning for TV Channels on page 16.

There is no power .

- Ensure the TV is plugged into a working electrical outlet.
- Ensure the power cable is securely attached to the TV.
- Press the Power/Standby button on the remote or on the back of the TV to turn the TV on.

The power is on, but there is no image on the screen .

- Ensure all cables are securely attached to the TV.
- Ensure all devices are connected correctly. Devices differ; see your device’s user manual for details.
- Adjust Brightness, Contrast, or Backlight. See Adjusting the Picture Settings on page 8.
- Press the INPUT button on the remote to select a different input source.

The sound is flat or dialog is not audible .

- Turn off Volume Leveling. See Adjusting the Audio Settings on page 14.

Where do I find information on the accessibility features of this product and other VIZIO products?

- Please visit vizio.com/accessibility,
- Email us at: Accessibility@vizio.com, or
- Give us a call at 1-877-698-4746.

How do I stream apps like Netflix to my VIZIO SmartCast® TV?

- Popular apps are located on the SmartCast Home™ screen, so you can simply navigate to the app row on your SmartCast TV to start streaming.
- You can also use Apple AirPlay 2 or Chromecast built-in™ to stream content from your device directly to your SmartCast TV. For more information, please visit:
 - VIZIO.com/Apple
 - VIZIO.com/Google

The colors on the TV don’t look right .

- Adjust the Color and Tint settings in the Picture menu. See Adjusting the Picture Settings on page 8.
- Select a pre-set picture mode. VIZIO recommends selecting Calibrated.
- Check all cables to ensure they are securely attached.

The image quality is not good .

- For the best image quality, view high-definition programs using digital sources. Connect your devices with HDMI cables.
- If you are using an antenna, the signal strength of the channel may be low. Ensure your antenna is connected securely to the TV and move the antenna around the room or close to a window for the best signal.

The picture is distorted .

- Move the TV away from electrical appliances, cars, and fluorescent lights.
- Ensure all cables are securely attached.

The TV image does not cover the entire screen .

- If you are using TV, AV, or Component with 480i input, go to Menu > Picture > Picture Aspect.

The TV has pixels (dots) that are always dark .

- Your HD TV is precision-manufactured using an extremely high level of technology. However, sometimes pixels may not display correctly. These types of occurrences are inherent to this type of product and do not constitute a defective product.

The buttons on the remote aren't working .

- Ensure you are only pressing one button at a time.
- Point the remote directly at the TV when pressing a button.
- Replace the remote batteries with new ones. See Replacing the Batteries on page 5.

There is no sound .

- Press Volume Up on the remote control.
- Press the MUTE button on the remote to ensure mute is off.
- Check the audio settings. See Adjusting the Audio Settings on page 14.
- Check the audio connections of external devices (Blu-ray player, game console, cable/satellite box) that are connected to the TV.
- If you are using an antenna, the signal strength of the channel may be low. Ensure your antenna is connected securely to the TV and move the antenna around the room or close to a window for the best signal.

- Set eARC to Off and use ARC mode.

I see “noise” or static on the screen .

- When your TV’s digital capabilities exceed a digital broadcast signal, the signal is up-converted (improved) to match your TV’s display capabilities. This upconverting can sometimes cause irregularities in the image.
- If you are using an antenna, the signal strength of the channel may be low. Ensure your antenna is connected securely to the TV and move the antenna around the room or close to a window for the best signal.

When I change input source, the TV image changes size .

- The TV remembers the viewing mode on each input source. If the viewing mode on the new input source differs from the one on the input source you switch from, the difference may be noticeable.
- See Changing the Picture Aspect Ratio on page 9.

How do I download the VIZIO SmartCast Mobile™ App?

- Make sure your phone or tablet is connected to a Wi-Fi network. Open a browser on your phone or tablet.
- Navigate to vizio.com/smartcastapp and follow the on-screen instructions to download the VIZIO SmartCast Mobile™ App.

How do I change the Inputs?

- Press the INPUT button on the back of the TV to cycle through the Inputs.
- Press the INPUT button on the basic remote to cycle through the Inputs.
- Make sure the VIZIO SmartCast Mobile™ app is installed on your phone or tablet. Open the VIZIO SmartCast Mobile app. Tap on the Device list and select your TV. Tap on the Input key and select the Input of your choice

How do I connect to my Wi-Fi network?

- On your TV remote, press the MENU button then go to Network > Select your Wi-Fi name > Enter password.
- Open the VIZIO SmartCast Mobile™ app on your phone or tablet. Tap on the Menu Tab > SmartCast Devices > Your TV/Device Name > Network
- Tap on the Settings icon > Network > Wireless Access Points. Select your Wi-Fi network from the list, enter the Wi-Fi password, and tap Connect.

How do I exit Demo Mode?

- Press and hold the INPUT button on the back of the TV to exit the demo mode.

How do I watch Cable/Antenna TV channels?

- If you subscribe to cable or satellite, simply connect an HDMI cable (not included) to the receiver.
- If you use external antennas to watch local broadcast channels, use a coaxial cable to connect.

Some of my Channels are missing .

- Press the MENU button on your TV remote and select the channels option. Then select Find Channels.
- Open the VIZIO SmartCast Mobile app on your phone or tablet.
- Click on: Menu Tab > SmartCast Devices > Your TV/Device Name > Channels > Find Channels.

How do I disable/enable Viewing Data?

- Press the MENU button on your remote and select ADMIN & PRIVACY. Then select Viewing Data to turn the feature on or off.

The television will not turn on using Alexa or Google Assistant .

- Ensure the television is in Quick Start Mode.
- Tap on Menu > System > Power Mode > Quick Start.

How do I know I am getting 4K resolution or HDR content such as Dolby Vision?

- As you are watching content on the television, press the INFO button on the remote or VIZIO SmartCast Mobile app. You will see the current resolution being displayed along with the version of video.
- HDR will show as a Dolby Vision icon, HDR10 or HLG.

Specifications

	V435-H1	V435-H11	V555-H1	V555-H11
Size	43"	43"	55"	55"
Viewable Area	42.5"	42.5"	54.5"	54.5"
PRODUCT DIMENSIONS				
Dimensions w/ Stand	38.31" x 24.52" x 8.35" (973.2 x 622.8 x 212 mm)	38.31" x 24.52" x 8.35" (973.2 x 622.8 x 212 mm)	49.06" x 30.87" x 10.24" (1246.20 x 784.10 x 260.10 mm)	49.06" x 30.87" x 10.24" (1246.20 x 784.10 x 260.10 mm)
Dimensions w/o Stand	38.31" x 22.35" x 3.31" (973.2 x 567.8 x 84 mm)	38.31" x 22.35" x 3.31" (973.2 x 567.8 x 84 mm)	49.06" x 28.47" x 3.39" (1246.20 x 723.10 x 86.30 mm)	49.06" x 28.47" x 3.39" (1246.20 x 723.10 x 86.30 mm)
Weight w/ Stand	15.87 lb (7.2 kg)	15.87 lb (7.2 kg)	30.29 lb (13.74 kg)	30.29 lb (13.74 kg)
Weight w/o Stand	15.65 lb (7.1 kg)	15.65 lb (7.1 kg)	29.83 lb (13.53 kg)	29.83 lb (13.53 kg)
Mounting Screw Size	M6	M6	M6	M6
Hole Pattern	200 mm x 200 mm	200 mm x 200 mm	300 mm x 200 mm	300 mm x 200 mm
PICTURE QUALITY				
Maximum Resolution	3840 x 2160 (UHD)	3840 x 2160 (UHD)	3840 x 2160 (UHD)	3840 x 2160 (UHD)
LCD Backlight	Full Array LED	Full Array LED	Full Array LED	Full Array LED
Dynamic Motion Rate	120	120	120	120
INPUTS / OUTPUTS				
HDMI Inputs	3	3	3	3
Composite Video Input	1	1	1	1
Ethernet Input	1	1	1	1
RF Antenna Input	1	1	1	1
USB	1	1	1	1
Audio Output	HDMI ARC, Analog Stereo Out, Digital Optical	HDMI ARC, Analog Stereo Out, Digital Optical	HDMI ARC, Analog Stereo Out, Digital Optical	HDMI ARC, Analog Stereo Out, Digital Optical
OTHER				
Remote Control Type	IR Remote	IR Remote	IR Remote	IR Remote
Power Consumption	80.42 W	80.42 W	99.35 W	99.35 W
Standby Power	<0.5W	<0.5W	<0.5W	<0.5W
Voltage	120V	120V	120V	120V
OSD Language	English, French, Spanish	English, French, Spanish	English, French, Spanish	English, French, Spanish
Certification	UL, cUL, FCC Class B, BETS-7/ICES-003 Class B, IC, HDMI (CEC, ARC) Dolby Audio, Dolby Vision	UL, cUL, FCC Class B, BETS-7/ICES-003 Class B, IC, HDMI (CEC, ARC) Dolby Audio, Dolby Vision	UL, cUL, FCC Class B, BETS-7/ICES-003 Class B, IC, HDMI (CEC, ARC) Dolby Audio, Dolby Vision	UL, cUL, FCC Class B, BETS-7/ICES-003 Class B, IC, HDMI (CEC, ARC) Dolby Audio, Dolby Vision

	V585-H1	V585-H11	V705-H1
Size	58"	58"	70"
Viewable Area	57.5"	57.5"	69.5"
PRODUCT DIMENSIONS			
Dimensions w/ Stand	51.38" x 32.43" x 10.24" (1305.08 x 823.6 x 260.1 mm)	51.38" x 32.43" x 10.24" (1305.08 x 823.6 x 260.1 mm)	62.54" x 37.76" x 13.04" (1588.6 x 959 x 331.2mm)
Dimensions w/o Stand	51.38" x 30.02" x 3.39" (1305.08 x 762.6 x 86.2 mm)	51.38" x 30.02" x 3.39" (1305.08 x 762.6 x 86.2 mm)	62.54" x 35.04" x 3.46" (1588.6 x 890 x 87.9mm)
Weight w/ Stand	32.19 lb (14.6 kg)	32.19 lb (14.6 kg)	52.48 lb (23.8 kg)
Weight w/o Stand	31.75 lb (14.4 kg)	31.75 lb (14.4 kg)	51.37 lb (23.3 kg)
Mounting Screw Size	M6	M6	M8
Hole Pattern	300 mm x 200 mm	300 mm x 200 mm	400 mm x 200 mm
PICTURE QUALITY			
Maximum Resolution	3840 x 2160 (UHD)	3840 x 2160 (UHD)	3840 x 2160 (UHD)
LCD Backlight	Full Array LED	Full Array LED	Full Array LED
Dynamic Motion Rate	120	120	120
INPUTS / OUTPUTS			
HDMI Inputs	3	3	3
Composite Video Input	1	1	1
Ethernet Input	1	1	1
RF Antenna Input	1	1	1
USB	1	1	1
Audio Output	HDMI ARC, Analog Stereo Out, Digital Optical	HDMI ARC, Analog Stereo Out, Digital Optical	HDMI ARC, Analog Stereo Out, Digital Optical
OTHER			
Remote Control Type	IR Remote	IR Remote	IR Remote
Power Consumption	93.3 W	93.3 W	118.64 W
Standby Power	<0.5W	<0.5W	<0.5W
Voltage	120V	120V	120V
OSD Language	English, French, Spanish	English, French, Spanish	English, French, Spanish
Certification	UL, cUL, FCC Class B, BETS-7/ICES-003 Class B, IC, HDMI (CEC, ARC) Dolby Audio, Dolby Vision	UL, cUL, FCC Class B, BETS-7/ICES-003 Class B, IC, HDMI (CEC, ARC) Dolby Audio, Dolby Vision	UL, cUL, FCC Class B, BETS-7/ICES-003 Class B, IC, HDMI (CEC, ARC) Dolby Audio, Dolby Vision

Warning

This content is compiled from multiple sources and is provided for reference purposes only. It may not be complete or fully applicable to all situations. If you are unable to resolve your issue, please contact the product manufacturer or an authorized service provider for official support.

