

## Introducing your new oven

### Overview

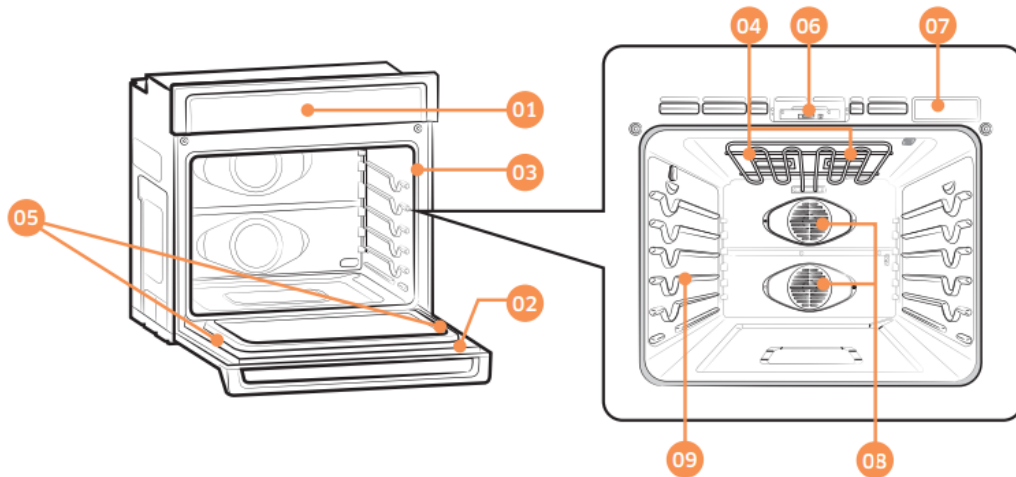

- |                       |                   |                   |
|-----------------------|-------------------|-------------------|
| 01 Oven control panel | 02 Oven door      | 03 Oven gasket    |
| 04 Halogen lamp *     | 05 Door LED light | 06 Door latch     |
| 07 Water Reservoir    | 08 Convection fan | 09 Shelf position |

### What's included with your oven

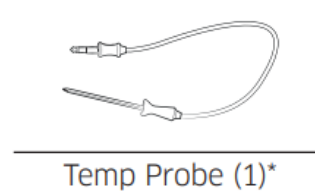
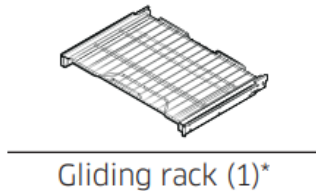
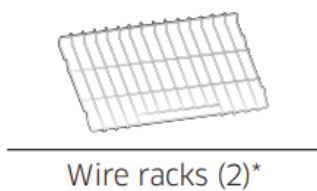

**NOTE** If you need an accessory marked with a \*, you can buy it from the Samsung Contact Center (1-800-726-7864).

### Before you begin

Clean the oven thoroughly before using it for the first time. Then, remove the accessories, set the oven to Bake, and then run the oven at 400 °F for 1 hour. There will be a distinctive odor. This is normal.

Ensure your kitchen is well ventilated during this conditioning period.

## Energy saving tips

- During cooking, the oven door should remain closed except when you turn food over. Do not open the door frequently during cooking to maintain the oven temperature and to save energy.
- If cooking time is more than 30 minutes, you can switch the oven off 5-10 minutes before the end of the cooking time to save energy. The residual heat will complete the cooking process.
- To save energy and reduce the time needed for re-heating the oven, plan oven use to avoid turning the oven off between cooking one item and the next.
- Whenever possible, cook more than one item at a time.

## Water reservoir

The water reservoir is used for the Steam Bake, Steam Roast, and Hybrid Clean functions and also to remove water scale that may form on the oven walls, especially after Steam Baking, Steam Roasting, and Hybrid cleaning. Fill it with water in advance of Steam cooking or descaling.

1. Locate the water reservoir. The water reservoir is on the right side of the oven, just above the oven opening. Touch Reservoir  on the control panel. The oven ejects the water reservoir. Grasp the front of the reservoir, and then slide it out to remove it.

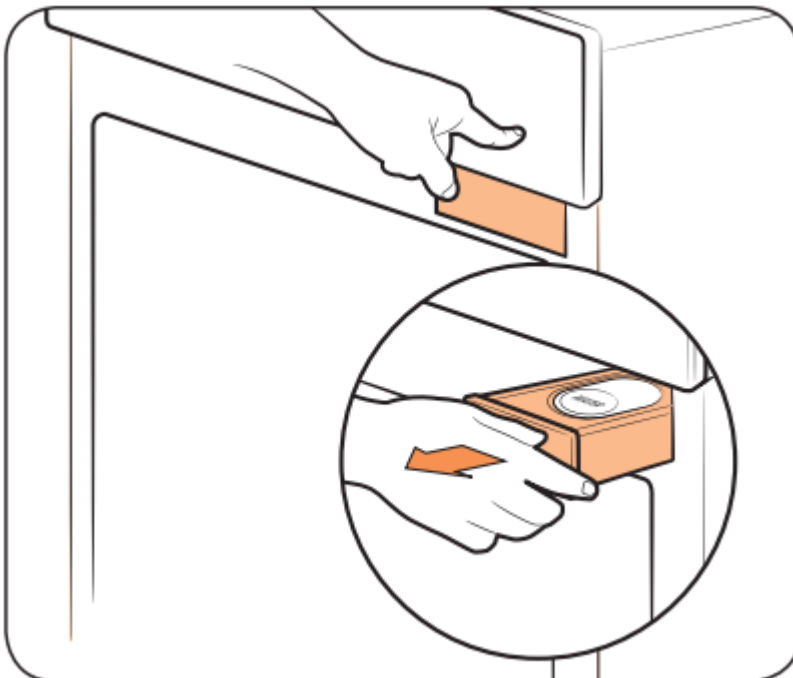

2. Open the reservoir cap, and then fill the reservoir with 22 oz (650ml) of drinkable water.

**NOTE** You can open the reservoir by removing the rubber cap or by removing the clear plastic top.

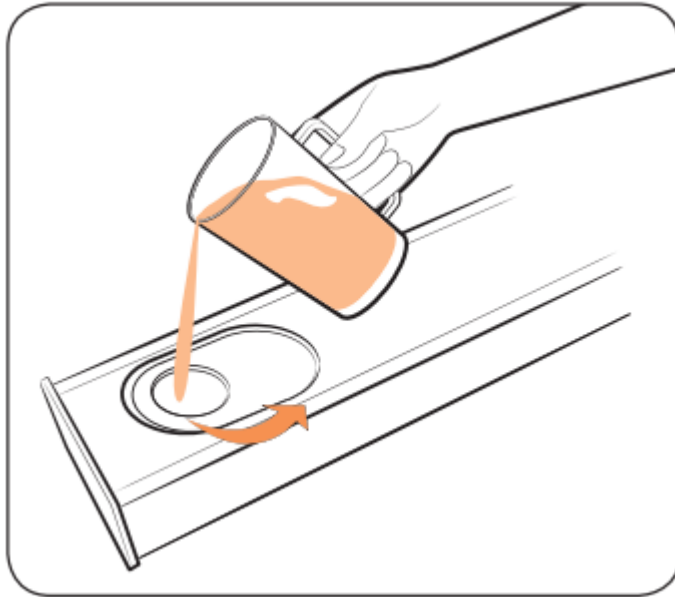

3. Replace the cap or the clear plastic top, and then slide the water reservoir back into the reservoir slot.

4. Push the reservoir in. There will be soft click when it is in place correctly. Touch Reservoir  . The oven retracts the water reservoir.

5. Close the oven door.

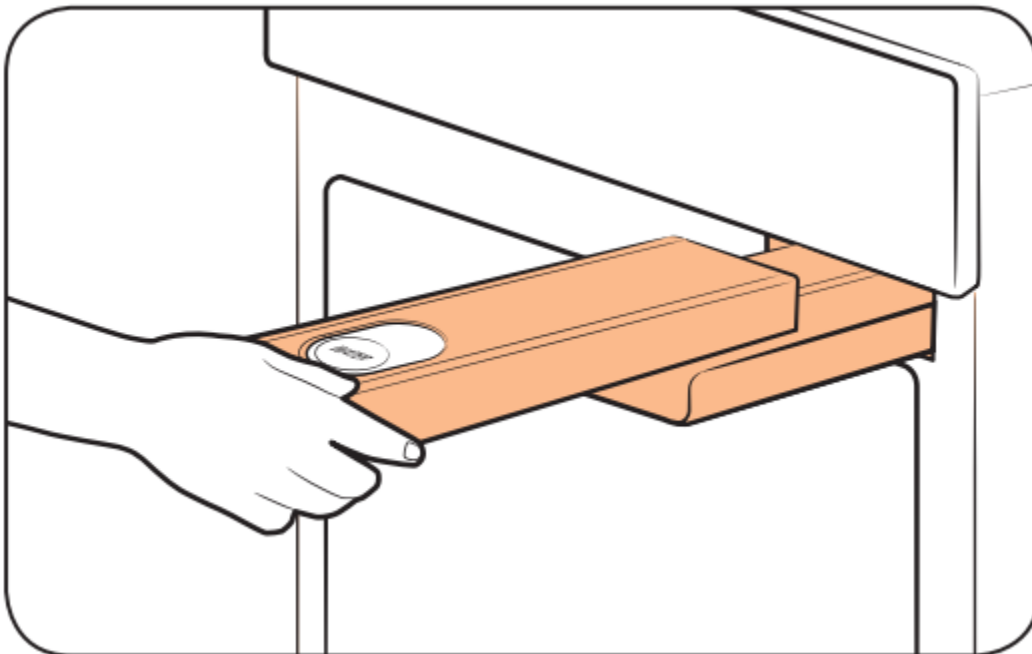

**NOTE** Do not exceed the max line.

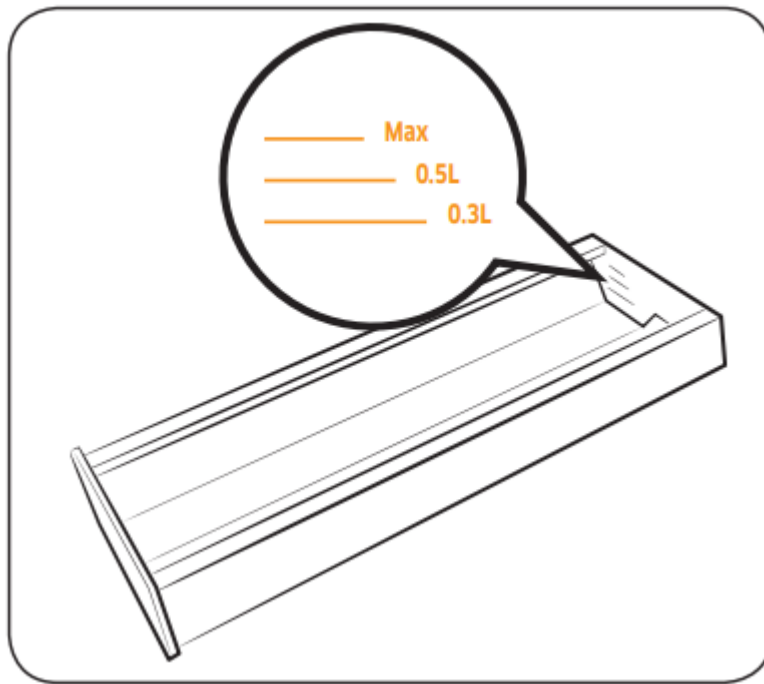

**NOTE** Make sure the cap and the upper portion of the water reservoir (labeled A) are closed before using the oven.

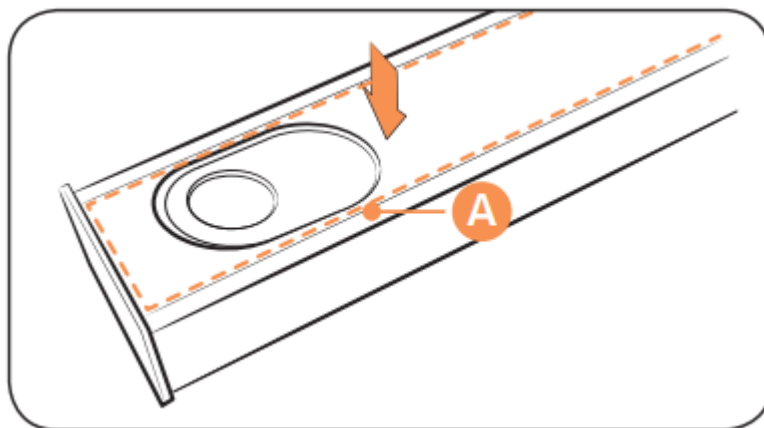

**CAUTION** The water reservoir becomes hot during the cooking. Make sure you wear oven gloves to remove or refill the water reservoir.

**NOTE**

- If Reservoir  on the control panel is blinking, the water reservoir is not closed properly. Close the reservoir completely.
- If 'Hot' appears on the display, be careful. The oven and the water reservoir are hot.

# Operating the oven

## The oven control panel

READ THE INSTRUCTIONS CAREFULLY BEFORE USING THE OVEN. For satisfactory use of your oven, become familiar with the various features and functions of the oven as described below. Detailed instructions for each feature and function follow later in this user manual.

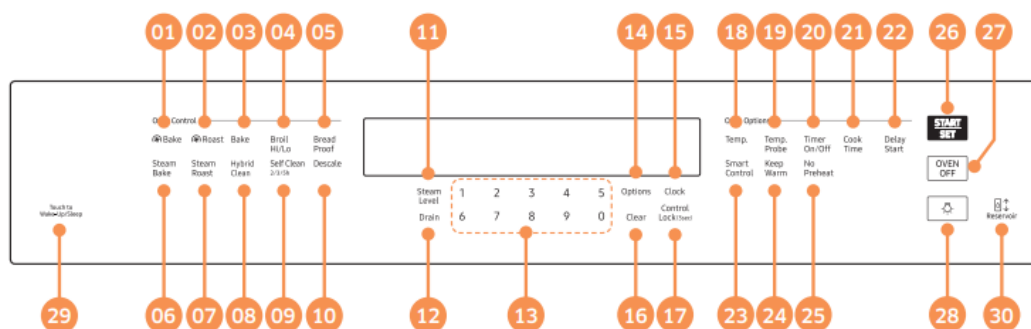

01  **Bake (Convection Bake):** Use to select the Convection Bake function. (Additionally, use to activate the No Preheat function in this mode.)

02  **Roast (Convection Roast):** Use to select the Convection Roast function. (Additionally, use to activate the No Preheat function in this mode.)

03 **Bake:** Use to select the Bake function.

04 **Broil Hi/Lo:** Use to select the Broil function.

05 **Bread Proof:** Use to select the Bread Proof function.

06 **Steam Bake:** Use to select the Steam Bake function.

07 **Steam Roast:** Use to select the Steam Roast function.

08 **Hybrid Clean:** Use to select the Hybrid Clean function.

09 **Self Clean 2/3/5h:** Use to select the Self-cleaning function. While Self-cleaning is running in one oven, you cannot use the other oven for any function.

10 **Descale:** Use to select the Descale function.

11 **Steam Level:** Use to select a steam level (Lo, Mid, Hi).

12 **Drain:** Use to select the drain function.

13 **Number pad:** Use to set any function requiring numbers such as the time of day on the clock, the timer, the oven temperature, the start time, and the length of operation for timed baking, etc.

14 **Options:** Use to bring up the User Preference menu in the display.

15 **Clock:** Use to set the time of day.

16 **Clear:** Use to cancel a previously entered temperature or time.

17 **Control Lock(3sec):** Use to disable all oven functions.

18 **Temp.:** Use to change the temperature when the oven is operating.

19 **Temp. Probe:** Use to activate the Temp Probe mode.

20 **Timer On/Off:** Use to set or cancel the kitchen timer. The kitchen timer does not start or stop cooking.

21 **Cook Time:** Touch and then use the number pad to set the amount of time you want your food to cook. The oven will shut off when the cooking time has run out.

22 **Delay Start:** Use to set the oven to start and stop automatically at a time you set.

23 **Smart Control:** Use to select the Smart Control feature.

24 **Keep Warm:** Use to select the Keep Warm function to keep cooked foods warm.

25 **No Preheat:** Use to activate the No Preheat function in the Convection Bake and Convection Roast modes.

26 **START/SET:** Use to start any cooking or cleaning function in the oven.

27 **OVEN OFF:** Use to cancel all oven operations except the clock and timer.

28 **Lamp**  : Use to turn the light (Oven and Door) on or off.

29 **Touch to Wake-Up/Sleep:** Use to activate or deactivate buttons and functions on the display.

30 **Reservoir**  : Use to open the water reservoir for Steam Bake, Steam Roast and Hybrid Clean cleaning.

## Control panel display modes

### Sleep Mode

Your control panel will remain in a sleep mode when not in use. Only the clock will display. You will need to wake the control panel to begin any function.

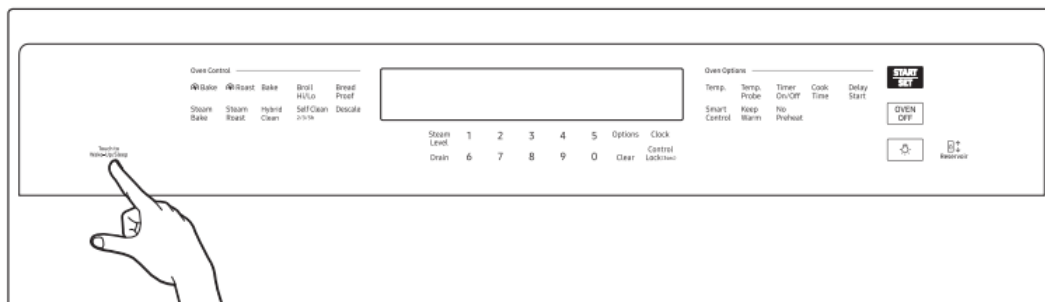

### Wake Mode

To wake the control panel, touch **Touch to Wake-Up/Sleep**. After 2 minutes without activity (or one minute when the oven is operating in standby mode), the control panel will return to Sleep mode.

### Setting the clock

The clock must be set to the correct time of day for the automatic oven timing functions to work properly.

- The time of day cannot be changed during timed cooking, delay-timed cooking, or a self-cleaning cycle.
- You can choose between a 12-hour or 24-hour display. The default is 12-hour.

### How to set the clock

1. Touch **Clock**.
2. Touch **Clock** to select AM or PM. (Skip this step if you are setting the clock to 24 hour display mode.)
3. Touch keys in the **number pad** to set the current time of day.
4. Touch **Clock** or **START/SET** to save the changes.

### Setting the kitchen timer

The kitchen timer serves as an extra timer that will beep when the set time has elapsed. It does not start or stop cooking functions. You can use the kitchen timer with any of the other oven functions.

### How to set the timer

1. Touch **Timer On/Off**.
2. Touch number keys in the **number pad** to set the hours and minutes. The timer can be set for any amount of time from 1 minute to 9 hours and 59 minutes. If you make a mistake, touch **Clear**, and then enter the amount of time again.
3. Touch **Timer On/Off** or **START/SET**.
4. When the set time has elapsed, the oven will beep and the display will show End until you touch **Timer On/Off**. You can cancel the timer at any time by touching **Timer On/Off**.

### Control Lockout

Control Lockout lets you lock the buttons on the touch pad so they cannot be activated accidentally. Control Lock also locks the oven door so it cannot be opened. You can only activate Control Lockout when the oven is in standby mode.

### How to activate the Control Lockout

1. Cancel or turn off all other functions.

2. Touch **Control Lock(3sec)** for 3 seconds.

The oven will display "**Loc**" and the lock icon along with the current time.

#### NOTE

- Control Lockout is available only when the oven temperature is under 400 °F.
- All other functions must be cancelled before you activate Control Lockout.

#### How to unlock the controls

Touch **Control Lock(3sec)** for 3 seconds.

"**Loc**" and the lock icon will disappear from the display.

#### NOTE

It may take up to 10 seconds for the door to unlock.

#### Timed Cooking

In Timed Cooking mode, the oven turns on immediately and cooks for the length of time you select. At the end of the cooking time, the oven turns off automatically.

- You can use the Timed Cooking only with another cooking operation (Convection Bake, Convection Roast, Bake, Steam Bake, Steam Roast).

#### How to set the oven for Timed Cooking

1. Touch the pad for the cooking operation you want, eg. **Bake**.

Enter the temperature you want, for example, 400 °F, using the number pad. (The default temperature is 350 °F).

2. Touch **Cook Time**. Enter the number of hours/minutes you want the oven to stay on using the **number pad**. You can set the cooking time for any amount of time from 1 minute to 9 hours and 59 minutes.

3. Touch **START/SET** to begin cooking. The temperature display will start to change once the oven temperature reaches 175 °F.

The oven will continue to cook until the set amount of time has elapsed, then turn off automatically unless you set the Keep Warm feature. (Refer to the **Using Keep Warm** section on page 30.)

4. You can cancel a cook time at any time by setting the cook time to 0 minutes. (Touch **Cook Time** -> set cook time to 0 min -> touch **START/SET**)

- When Timed Cooking is done, the oven will beep 10 times.

#### CAUTION

Use caution with the **Timed Cooking** or **Delay Start** features. You can use these features to cook cured or frozen meats and most fruits and vegetables. For food that can easily spoil, such as milk,

eggs, and unfrozen or fresh fish, meat, or poultry, chill them in the refrigerator first. Even when chilled, they should not stand in the oven for more than 1 hour before cooking begins, and should be removed promptly when cooking is completed. Eating spoiled food can result in sickness from food poisoning.

## Delay Start

With Delay Start, the oven's timer turns the oven on and off at times you select in advance.

- You can use the Delay Start only with another cooking operation (Convection Bake, Convection Roast, Bake, Steam Bake, Steam Roast, Self Clean).
- You can set the oven for a delay start before setting other cooking operations.
- The clock must be set to the current time.

### How to set the oven for delay start









1. Position the oven rack(s) and place the food in the oven.
2. Touch the pad for the cooking operation you want, eg. **Bake**.  
The default temperature is 350 °F.
3. Enter the temperature you want, eg. 375 °F, using the **number pad**.
4. Set the cooking time if you want. (Refer to the section on the timed cooking feature on page 21).
5. Touch **Delay Start**. Use the **number pad** to set the time.
6. Touch **START/SET**. At the set time, a short beep will sound. The oven will begin to cook.

## Turning the light on and off

- The oven light turns on and door light turns off automatically when the door is opened.
- The oven light turns off automatically when the door is closed.
- You can turn the oven and door light on and off manually by touching the **Lamp** 

## Minimum and maximum settings

All the features listed in the table below have minimum and maximum time or temperature settings. A beep will sound each time a pad on the control panel is pressed and the entry is accepted. An error tone will sound in the form of a long beep if the entered temperature or time is below the minimum or above the maximum setting for the feature.

FEATURE		MINIMUM	MAXIMUM
	Bake	175 °F (80 °C)	550 °F (285 °C)
	Broil	LO	HI
	Convection Bake	175 °F (80 °C)	550 °F (285 °C)
	Convection Roast	175 °F (80 °C)	550 °F (285 °C)
	Steam Bake	230 °F (110 °C)	550 °F (285 °C)
	Steam Roast	230 °F (110 °C)	550 °F (285 °C)
	Self Clean	2 Hr.	5 Hr.
	Hybrid Clean	-	2 Hr.
	Keep Warm	-	3 Hr.

### Oven rack positions

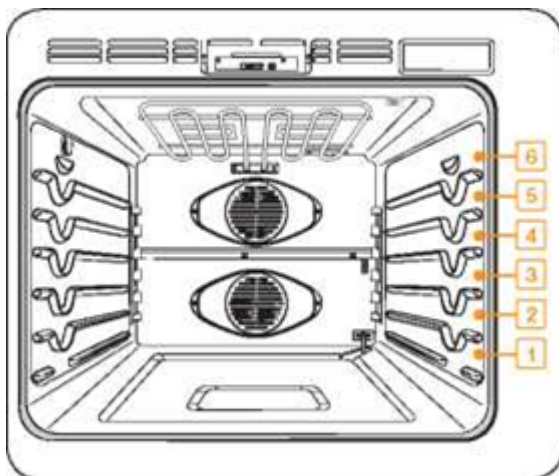

Recommended rack position for cooking

TYPE OF FOOD	RACK POSITION
Broiling hamburgers	6
Broiling meats or small cuts of poultry, fish	3-5
Bundt cakes, pound cakes, frozen pies, casseroles	4 or 3
Angel food cakes, small roasts	2
Turkey, large roast, hams, fresh pizza	1

- This table is for reference only.

### Rack and Pan placement

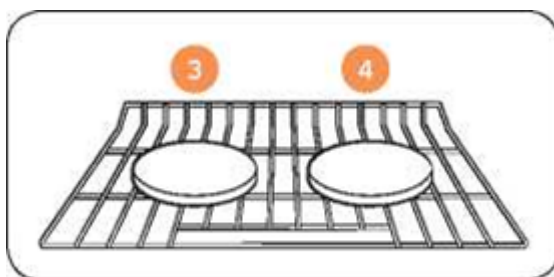

Single Oven Rack

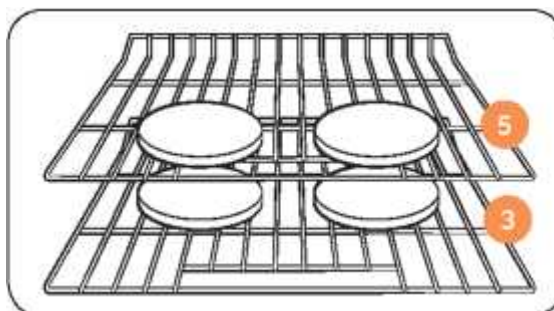

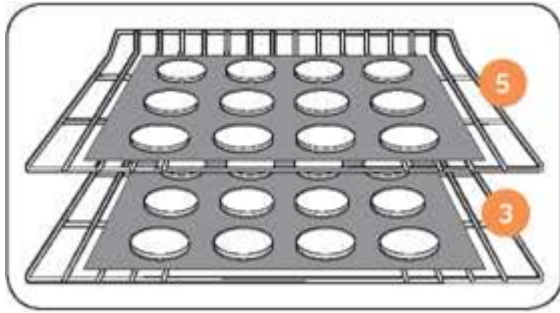

Centering baking pans in the oven as much as possible will produce better results. If baking with more than one pan, place the pans so each has at least 1" to 1½" of air space around it.

When baking on a single oven rack, place the oven rack in position 3 or 4. See the figure on the left. When baking cakes and cookies on multiple racks, place the oven racks in position 3 and 5.

### Using Multiple Oven Racks

Type of Baking	Rack Positions
Cakes and cookies	3 and 5

### Before using the racks

Each rack has stops that need to be placed correctly on the supports. These stops will keep the rack from coming completely out.

### REMOVING THE RACKS

1. Pull the rack straight out until it stops.
2. Lift up the front of the rack, and then pull it out.

### REPLACING THE RACKS

1. Place the end of the rack on the support.
2. Tilt the front end up and push the rack in.

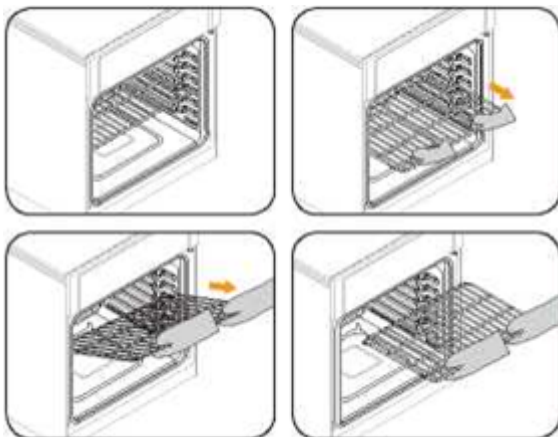

## CAUTION

- Do not cover a rack with aluminum foil or place aluminum foil on the oven bottom. This will hamper heat circulation, resulting in poor baking, and may damage the oven bottom.
- Arrange the oven racks only when the oven is cool.

## Using the Gliding Rack

The fully extendable Gliding Rack makes food preparation easier, especially when you are preparing heavier dishes. The Gliding Rack has 2 glide tracks that allow you to extend the rack well out of the oven without touching the sides of the oven walls.

### Installing the Gliding rack

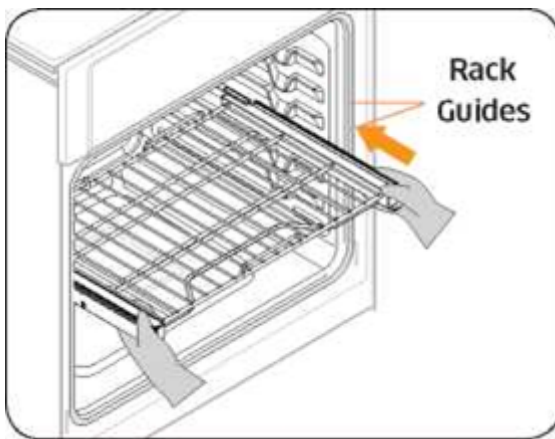

With the Gliding Rack in the "Closed" position and the oven off, carefully insert the Gliding Rack between the guides until the rack reaches the back.

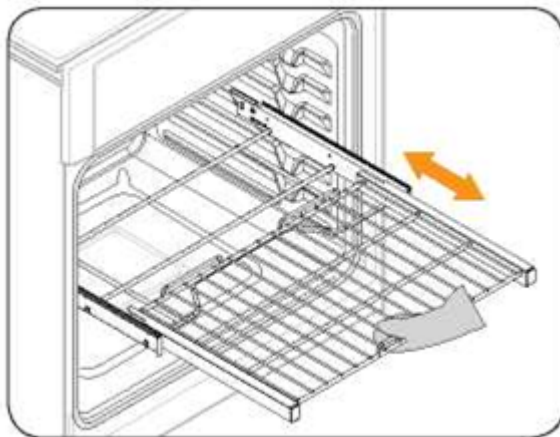

When using the Gliding Rack in the oven, be sure to pull on the handle of the rack only to slide it in and out. If you grasp the frame while using the rack, the entire Gliding Rack will be removed. Make sure you use oven mitts when handling the Gliding Rack during cooking.

### Removing the Gliding Rack

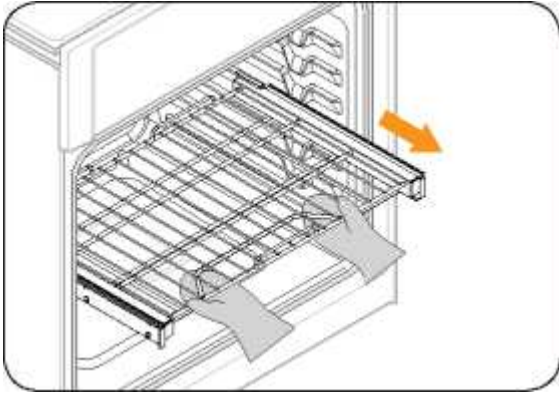

With the Gliding Rack in the "Closed" position and the oven off and cool, grasp the rack and frame and pull both forward to remove.

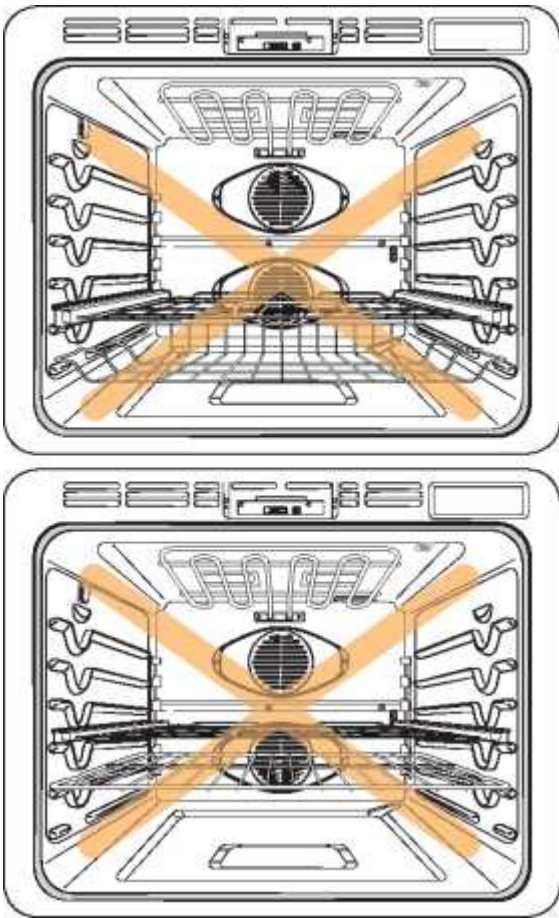

**CAUTION**

Do not install the Gliding Rack directly above the Flat Rack and Recessed rack. You will not be able to install it properly and the oven could fall.

**NOTE**

You can install the Gliding rack in any rack positions except the lowest (level 1) rack position in the oven.



## Baking

The oven can be programmed to bake at any temperature from 175 °F to 550 °F. Baking temperature and time will vary depending on the ingredients and the size and shape of the baking pan used. Dark or nonstick coatings may cook faster with more browning.

### How to set the oven for baking

1. Touch **Bake**.
2. Enter the temperature you want using the **number pad**, eg. 3, 7, 5.
3. Touch **START/SET**. The temperature display will start to change once the oven temperature reaches 175 °F.
4. If you want to cancel baking or if you have finished, touch **OVEN OFF**.
  - Place food in the oven after preheating if the recipe calls for it. Preheating is very important for good results when baking cakes, cookies, pastry, and breads. After the oven has reached the desired temperature, the oven will beep 5 times.

### NOTE

For performance reasons, the convection fan may turn on or off during baking.

If you are using an oven thermometer in the oven cavity, the temperature registered by the thermometer may differ from the actual set oven temperature.

### How to adjust the temperature while cooking

1. Touch **Temp..** The display will show the present temperature, eg. 375 °F
2. Enter the temperature you want, eg. 425°F, using the **number pad**.
3. Complete the entry by touching **START/SET**.

## Convection baking

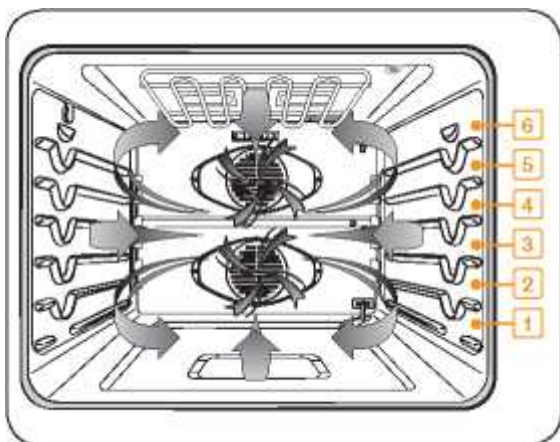

By using the Convection Bake, you will be able to cook faster. Convection baking uses a fan to circulate the oven's heat evenly and continuously within the oven. This improved heat

distribution allows for even cooking and excellent results while using multiple racks at the same time. Foods cooked on a single oven rack will generally cook faster and more evenly with convection baking. Multiple oven rack cooking may have slightly increased cooking times for some foods, but the overall result is time saved. Breads and pastries brown more evenly.

You can program the oven for convection baking at any temperature between 175 °F and 550 °F.

### Tips for convection baking

The amount of time you save will vary depending on the amount and type of food you are cooking. When baking cookies or biscuits, you should use pans with no sides or very low sides to allow the heated air to circulate around the food. Using a pan with a dark finish will produce faster cooking times.

When using convection baking with a single rack, place the oven rack in **position 3** or **4**. If cooking on multiple racks, place the oven racks in **position 3** and **5**.

When baking a cake, using the bake mode (not the convection bake mode) will produce better results.

### How to set the oven for convection baking

1. Touch  **Bake**. The No Preheat key is activated on the control panel. Touch **No Preheat** if you want to use the No Preheat feature. (Refer to the **No Preheat** section on page 27.)
2. Enter the temperature you want, eg. 400 °F, using the **number pad**.
3. Touch **START/SET**.

The temperature display will start to change once the oven temperature reaches 175 °F.

The oven will beep 6 times when the oven reaches the adjusted oven temperature.

4. If you want to cancel convection baking or if you have finished, touch **OVEN OFF**.

- The convection oven fan shuts off when the oven door is opened.
- DO NOT leave the door open for long periods of time while using convection cooking or you may shorten the life of the convection heating element.

### NOTE

- If you leave the oven door open for more than 2 minutes when the oven is on, all heating elements will shut off automatically.
- When you have finished cooking, the cooling fan will continue to run until the oven has cooled down.

### NOTE

- For performance reasons, the convection fan may turn on or off during baking.

- If you are using an oven thermometer in the oven cavity, the temperature registered by the thermometer may differ from the actual set oven temperature.

## Convection roasting

Convection roasting is good for cooking large tender cuts of meat uncovered.

Heat comes from the top heating element. The convection fan circulates the heated air evenly over and around the food. Meat and poultry are browned on all sides as if they were cooked on a rotisserie. The heated air seals in juices quickly for moist and tender results while, at the same time, creating a rich golden brown exterior.

### How to set the oven for convection roasting

1. Touch  **Roast. No Preheat** is activated on the control panel. Touch **No Preheat** if you want to use the No Preheat feature. (Refer to the **No Preheat** section on this page.)
2. Enter the temperature you want, eg. 400 °F, using the **number pad**.
3. Touch **START/SET**.

The temperature display will start to change once the oven temperature reaches 175 °F. The oven will beep 6 times when the oven reaches the adjusted oven temperature.

4. If you want to cancel convection roasting or if you have finished, touch **OVEN OFF**.

- The convection oven fan shuts off when the oven door is opened.
- DO NOT leave the door open for long periods of time while using convection cooking or you may shorten the life of the convection heating element.

### NOTE

- If you leave the oven door open for more than 2 minutes when the oven is on, all heating elements will shut off automatically.
- When you have finished cooking, the cooling fan will continue to run until the oven has cooled down.

### NOTE



- For performance reasons, the convection fan may turn on or off during roasting.
- If you are using an oven thermometer in the oven cavity, the temperature registered by the thermometer may differ from the actual set oven temperature.

## No Preheat

Use No Preheat to cook without the pre-heating cycle.

This function is only available for Convection Bake and Convection Roast.

### How to set the oven for No Preheat

1. Touch  **Bake** or  **Roast**. **No Preheat** is activated on the control panel.
2. Touch **No Preheat**.
3. Enter the temperature you want, eg. 400 °F, using the **number pad**.
4. Touch **START/SET**.
5. The temperature display will show the set temperature.

**NOTE**

- For best performance, we recommend cooking on a single rack.

Type of Baking	Rack Positions
Baking	3 or 4
Roasting	1 or 2

- Place food in the oven before you start cooking when using the No Preheat feature.
- For best performance, preheat the oven when baking rising bakery products such as angel food cakes, bundt cakes, or puff pastries.

**Broiling**

Broiling is a method of cooking tender cuts of meat by direct heat under the broil element of the oven.

The high heat cooks quickly and gives a rich, brown outer appearance. Broil mode is best for meats, fish, and poultry up to 1" thick.

**How to set the oven for broiling**

1. Touch **Broil** once for Hi or twice for Lo.

Use Lo to cook foods such as poultry or thick cuts of meat thoroughly without over-browning them.

2. To start broiling, touch **START/SET**.

Broil one side until the food is browned. Turn over and broil the other side.

3. Touch **OVEN OFF** once you have finished cooking or if you want to cancel broiling.

**NOTE**

- This oven is designed for CLOSED DOOR broiling. The oven door must be closed during broiling.
- If you leave the oven door open for more than 2 minutes when the oven is on, all heating elements will shut off automatically.
- When you have finished cooking, the cooling fan will continue to run until the oven has cooled down.



- If you are using an oven thermometer in the oven cavity, the temperature registered by the thermometer may differ from the actual set oven temperature.

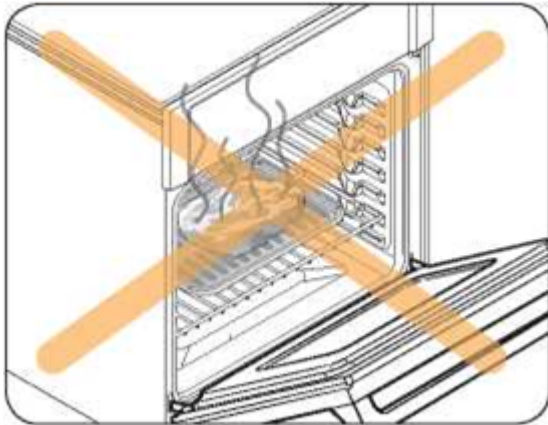

**CAUTION**

Always broil with the oven door closed. Use care when opening the door. Let hot air or steam escape before you remove food from or put food into the oven.

**Using Smart Control**

To use the oven's Smart Control, you must download Samsung's Smart Home app to a mobile device. Functions that can be operated using Samsung's Smart Home app may not work smoothly if communication conditions are poor or the oven is installed in a place with a weak Wi-Fi signal.

Please refer to the following table for the main functions that can be operated from the app.

When Smart Control on the oven is off	Monitoring (Oven, Probe), Oven off
When Smart Control on the oven is on.	Monitoring (Oven, Probe), Oven start, Oven off, Error check

**How to connect the oven**

1. Download and open the Samsung Smart Home app on your smart device.
2. Follow the app's on-screen instructions to connect your oven.
3. Once the process is complete, the connected  icon located on your oven displays and the app will confirm you are connected.
4. If the connection icon does not turn on, follow the instruction in the app to reconnect.

**To start the oven remotely**



1. Touch Smart Control.  appears in the display. The oven can now be started and controlled remotely by a connected mobile device.



When Smart Control is on you can:

- Remotely change oven settings (mode, time, temperature) using your mobile device.
- Remotely start the oven.
- Remotely turn off the oven.
- Once cooking starts, you can change the cooking time and temperature remotely.

NOTE

**Important:** Self clean mode cannot be started remotely.

NOTE

- Opening the oven door or touching Smart Control will delete  from the display and prevent you from turning the oven on or controlling the oven remotely.
- If  is not shown in the display, you can still monitor the oven's status and turn the oven off.
- When oven cooking is finished or cancelled,  will turn off.

## Using Options

This function lets you control various electronic control options. These options include Temp Adjust, Temp Unit, Auto Conversion, Time of Day, 12 hour energy saving, Sound On/Off, and Demo mode.

The option menu is only available when the oven is not being used (not cooking).

Options	Feature
1. Temp Adjust	Lets you correct the temperature in the oven.
2. Temp Unit	Lets you program the oven control to display temperatures in Fahrenheit or Centigrade.
3. Auto Conversion	Lets you set the Auto Conversion feature so that the oven automatically converts entered regular baking temperatures to convection baking temperatures, and then displays the convection temperatures.
4. Time of Day	Lets you set the clock to display the time of day in the 12 hour or 24 hour mode.
5. 12 hour energy saving	This feature automatically turns off the oven after 12 hours during baking functions or after 3 hours during a broil function.
6. Sound On/Off	Lets you set the oven controls to operate silently.
7. Wi-Fi On/Off	Lets you activate and de-activate the oven's wi-fi connection.
0. Demo mode	This option is for use by retail establishments for display purposes only.

## Temp Adjust

The temperature in the oven has been calibrated at the factory. When first using the oven, be sure to follow recipe times and temperatures. If you think the oven is too hot or too cool, you can correct the temperature in the oven. Before correcting, test a recipe by using a temperature setting that is higher or lower than the recommended temperature. The baking results should help you to decide how much of an adjustment is needed.

The oven temperature can be adjusted  $\pm 35$  °F ( $\pm 19$  °C).

How to correct the oven temperature

1. Touch **Options**, and then **1** on the **number pad**.
2. Touch **Options** to select higher or lower than the current temperature.
3. Enter the adjustment you want to make using the **number pad**. (0-35)
4. Touch **START/SET** to save the changes.

#### **NOTE**

This adjustment will not affect the broiling or the self-cleaning temperatures. The adjustment will be retained in memory after a power failure.

#### **Temp Unit (Fahrenheit or Celsius temperature selection)**

You can program the oven control to display the temperature in Fahrenheit or Celsius. The oven has been preset at the factory to display in Fahrenheit.

How to change the display from Fahrenheit to Celsius or Celsius to Fahrenheit

1. Touch **Options**, and then **2** on the **number pad**.
2. Touch **1** (Fahrenheit) or **2** (Celsius) on the **number pad**.
3. Touch **START/SET** to save the changes.

#### **Auto Conversion**

When you use the auto conversion feature, the convection auto conversion feature will automatically convert entered regular baking temperatures to convection baking temperatures.

If this feature is activated, the display will show the actual converted (reduced) temperature. For example, if you enter a regular recipe temperature of 350 °F and touch Oven Start/Set, the display will show the converted temperature of 325 °F. (Default setting : off)

How to enable or disable the auto conversion feature

1. Touch **Options**, and then **3** on the **number pad**.
2. Touch **1** (On) or **2** (Off) on the **number pad**.
3. Touch **START/SET** to save the changes.

#### **Time of Day (12hr/24hr)**

The oven control can be programmed to display time of day in the 12 hour or 24 hour mode.

The oven has been preset at the factory to display in the 12 hour mode.

How to change between the 12 and 24 hour time of day display

1. Touch **Options**, and then **4** on the **number pad**.
2. Touch **1** (12hr) or **2** (24hr) on the **number pad**.
3. Touch **START/SET** to save the changes.

#### **12 hour energy saving**

If you accidentally leave the oven on, this feature will automatically turn off the oven after 12 hours during baking functions or after 3 hours during a broil function.

How to turn the 12 hour energy saving feature on or off

1. Touch **Options**, and then **5** on the **number pad**.
2. Touch **1** (On) or **2** (Off) on the **number pad**.
3. Touch **START/SET** to save the changes.

### **Sound On/Off**

Using Sound On/OFF, you can set the oven controls to operate silently.

How to turn the sound on or off

1. Touch **Options**, and then **6** on the number pad.
2. Touch **1** (On) or **2** (Off) on the number pad.
3. Touch **START/SET** to save the changes.

### **Wi-Fi On/Off**

You can turn the oven's Wi-Fi connection on or off.

How to turn the Wi-Fi on or off

1. Touch **Options**, and then **7** on the number pad.
2. Touch **1** (On) or **2** (Off) on the number pad.
3. Touch **START/SET** to save the changes.

### **NOTE**

When you turn the oven's Wi-Fi connection off, Users can't set to easy setup. Demo mode

This option is for use by retail establishments for display purposes only.

(When Demo mode is on, the heating element is disabled and does not operate.) How to enable or disable the demo mode

1. Touch **Options**, and then **0** on the number pad.
2. Touch **1** (On) or **2** (Off) on the number pad.
3. Touch **START/SET** to save the changes.

# Maintaining your appliance

## Self-cleaning

This self-cleaning oven uses high temperatures (well above cooking temperatures) to burn off leftover grease and residue completely or reduce them to a finely powdered ash that you can wipe away with a damp cloth.

### CAUTION

- During the self-cleaning cycle, the outside of the oven will become very hot to the touch. Do not leave small children unattended near the appliance.
- Some birds are extremely sensitive to the fumes given off during the selfcleaning cycle of any oven. Move birds to another well-ventilated room.
- Do not line the oven walls, racks, bottom, or any other part of the oven with aluminum foil. Doing so will result in poor heat distribution, poor baking results, and cause permanent damage to the oven interior. Aluminum foil will melt and adhere to the interior surface of the oven.
- The oven door locks during self-cleaning. Do not force the oven door open. This can damage the automatic door locking system. Use care when opening the oven door after the self-cleaning cycle is complete. Stand to the side of the oven when opening the door to allow hot air or steam to escape. The oven may still be VERY HOT.

### Before a self-cleaning cycle



Fig. 1

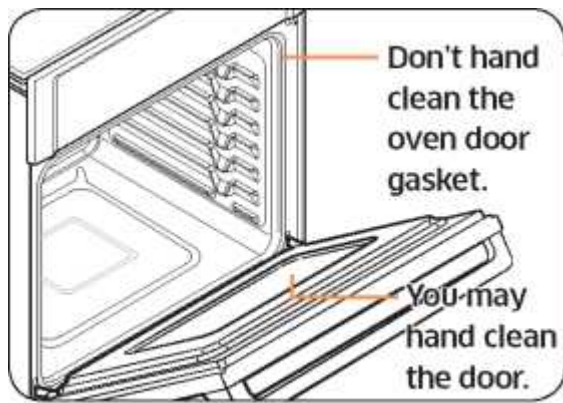

Fig. 2

We recommend venting your kitchen with an open window or using a ventilation fan or hood during the selfcleaning cycle.

Remove the wire rack, broil pan, broil pan insert, all cookware, and any aluminum foil from the oven.

Wipe up debris from the oven bottom. (Fig. 1)

The silver-colored oven racks can be self-cleaned, but they will darken, lose their luster, and become hard to slide. Residue on the front frame of the oven and outside the gasket on the door will need to be cleaned by hand. Clean these areas with hot water, soap-filled steel-wool pads, or cleansers such as Soft Scrub. Rinse well with clean water and dry.

Do not clean the gasket. The fiberglass material of the oven door gasket cannot withstand abrasion. It is essential for the gasket to remain intact. If you notice it becoming worn or frayed, have it replaced. (Fig. 2)

Make sure the oven light cover is in place and the oven light is off.

#### **NOTE**

Remove oven racks and accessories before starting the self-clean mode.

#### **How to run a self-cleaning cycle**

1. Select the length of time for the self-cleaning operation, eg. 3 hours.

Touch **Self Clean 2/3/5h** once for a 3 hour clean time, twice for a 5 hour clean time, or 3 times for a 2 hour clean time The default setting is 3 hours.

2. Touch **START/SET** to start the self-cleaning cycle.

The motor-driven door lock will engage automatically.

#### **NOTE**

You will not be able to start a self-cleaning cycle if the Control Lockout feature is activated or if the oven's temperature is too hot.

The oven door locks automatically. The display will show the cleaning time remaining. You cannot open the oven door until the temperature drops to a safe/cool temperature.

3. When the self-cleaning cycle is done, End will appear in the display and the oven will beep 6 times.

### How to delay the start of self-cleaning

Touch **Self Clean 2/3/5h**.

1. Select the desired self-clean time by touching **Self Clean 2/3/5h**.
2. Touch **Delay Start**.
3. Enter the time you want the self-clean cycle to start.
4. Touch **START/SET**.

The display will show Delay, Self clean, and the Lock icon. The motor-driven door lock will engage automatically.

5. The Self-Cleaning cycle will turn on automatically at the set time.

### How to turn off the self-cleaning feature

If you need to stop or interrupt a self-cleaning cycle:

1. Touch **OVEN OFF**.
2. You will be able to open the oven door once the oven has cooled down for approximately 1 hour.

### After a self-cleaning cycle

- You may notice some white ash in the oven. Wipe it up with a damp cloth after the oven cools. (If white spots remain, remove them with a soap-filled steel wool pad and rinse thoroughly with a vinegar and water mixture.)
- If the oven is not clean after one cycle, repeat the cycle.
- You cannot set the oven for cooking until the oven is cool enough for the door to unlock.

### Hybrid Cleaning

The Hybrid cleaning function saves time and energy by removing leftover grease and residue that you can then wipe away with a damp cloth.

#### CAUTION

- Do not line the oven walls, racks, bottom, or any other part of the oven with aluminum foil. Doing so will result in poor heat distribution, poor baking results, and cause permanent damage to the oven interior. Aluminum foil will melt and adhere to the interior surface of the oven.

- The oven door locks during Hybrid cleaning. Do not force the oven door open. This can damage the automatic door locking system. Use care when opening the oven door after a Hybrid Cleaning cycle is complete. Stand to the side of the oven when opening the door to allow hot air or steam to escape.

### Before a Hybrid cleaning cycle

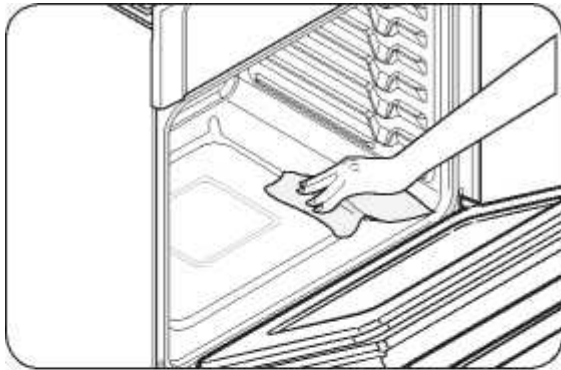

Fig. 1

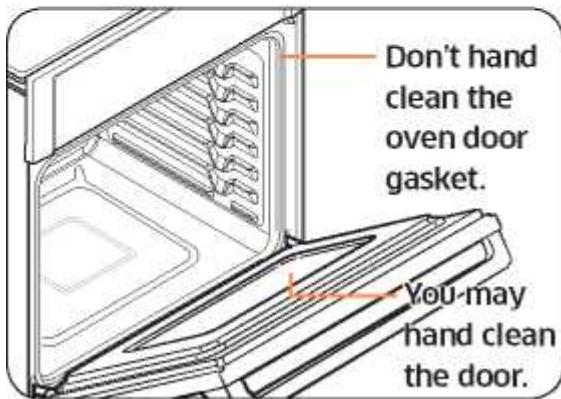

Fig. 2

Remove the wire rack, broil pan, broil pan insert, all cookware, and any aluminum foil from the oven.

Wipe up debris from the oven bottom. (Fig. 1)

The silver-colored oven racks can be Hybrid Cleaned, but they will darken, lose their luster, and become harder to slide.

Residue on the front frame of the oven and outside the gasket on the door will need to be cleaned by hand. Clean these areas with hot water, soap-filled steel-wool pads, or cleansers such as Soft Scrub. Rinse well with clean water and dry.

Do not clean the gasket. The fiberglass material of the oven door gasket cannot withstand abrasion. It is essential for the gasket to remain intact. If you notice it becoming worn or frayed, have it replaced. (Fig. 2)

Make sure the oven light cover is in place and the oven light is off.

### NOTE

Remove oven racks and accessories before starting the Hybrid clean mode.

### How to run a Hybrid cleaning cycle

1. Remove all accessories from the oven.
2. Open the oven door, and then touch Reservoir . The oven ejects the water reservoir. Grasp the front of the reservoir and pull it all the way out of the slot.
3. Pour approximately 20 oz (600ml) of water into the water reservoir. Use normal water only, not distilled water.

#### NOTE

You can open the reservoir by removing the rubber cap or by removing the clear plastic top.

4. Replace the rubber cap or clear plastic top.
5. Return the reservoir to the slot, and then push it in. There will be slight click when it is in place correctly. Touch Reservoir 0 X. The oven retracts the water reservoir.
6. Close the oven door.
7. Touch Hybrid Clean.
8. Touch START/SET. The motor-driven door lock will engage automatically. When the operation is complete, the display will blink and a beep will sound.
9. Touch OVEN OFF.
10. Clean the oven's interior. There will be a significant amount of water remaining on the bottom of the oven after a Hybrid cleaning cycle. Remove the residual water with a sponge or soft dry cloth.

#### NOTE

For Hybrid Cleaning, use exactly 20 oz (600ml) of water since this produces the best results.

### After a Hybrid cleaning cycle

- Take care when opening the door after a Hybrid cleaning procedure has ended. The water on the bottom is hot.
- Open the oven door and remove the remaining water with a sponge. Do not leave the residual water in the oven for any length of time. Wipe the oven clean and dry with a soft cloth. Do not forget to wipe under the oven door seal.
- Use a detergent-soaked sponge, a soft brush, or a nylon scrubber to wipe the oven interior. Remove stubborn residue with a nylon scourer. You can remove lime deposits with a cloth soaked in vinegar.
- If the oven remains dirty, you can repeat the procedure once the oven has cooled.

- For heavy residue, such as grease left over from roasting, we recommend that you rub detergent into the residue before activating the Hybrid cleaning function.
- After cleaning, leave the oven door ajar at a 15° angle to allow the interior enamel surface to dry thoroughly.

#### NOTE

- You will not be able to start a Hybrid cleaning cycle if the control lockout feature is activated or if the oven's temperature is too hot.
- The oven door locks automatically. The display will show the cleaning time remaining. You cannot to open the oven door until the temperature drops to a safe/cool temperature.
- If the oven is not clean after one cycle, repeat the cycle.
- You cannot set the oven for cooking until the oven is cool enough for the door to unlock.

#### Descale

If you use Steam Bake or Steam Roast frequently, we recommend descaling regularly to remove minerals from the oven that may affect the taste or quality of food cooked. When running a descaling cycle, use only descaling agents that are specific to steam ovens or coffee machines.

#### NOTE

If you use Steam Bake or Steam Roast functions for more than a total of 12 hours, the Descal indicator turns on. You can still enable the Steam Bake or Steam Roast functions for the next two hours without descaling. However, after those two hours are up, the Steam Bake or Steam Roast functions will be disabled until you run a descaling cycle.

1. Open the oven door, and then touch Reservoir . The oven ejects the reservoir. Grasp the front of the reservoir and pull it all the way out of the slot.
2. Empty and clean the water reservoir, and then fill it with 1.7 oz (50 ml) of descaling agent and 13.5 oz (400 ml) of water.

#### NOTE

You can open the reservoir by removing the rubber cap or by removing the clear plastic top.

3. Replace the rubber cap or clear plastic top.
4. Return the reservoir to the slot, and then push it in. There will be slight click when it is in place correctly. Touch Reservoir .
5. Close the oven door.
6. Touch Descal.
7. Touch START/SET. The oven starts descaling.

The Descaling cycle has 5 steps. The display will notify you as each step occurs.

Below are step 1 through 3.

Step 1	Apply descaling agents	Approx. 2 min.
Step 2	Descaling	Approx. 3 hrs.
Step 3	Draining	Approx. 4 min.

8. When the oven reaches step 4, you will see “Out” on the display.

Remove and empty the water reservoir, and then refill it with 22 oz (650ml) of drinkable water. The “In” message that appears momentarily will disappear. Close the oven door.

9. Touch START/SET. The oven continues to rinse and drain for 5 minutes, and then moves to step 5.

10. When Step 5 is complete, you will see “Out” on the display. Remove and clean the water reservoir, and then reinsert. Close the oven door.

11. Touch START/SET. The oven beeps, indicating descaling is complete.

## **WARNING**

Use only descaling agents that are specific to steam ovens or coffee machines.

## **CAUTION**

- The Water Supply LED blinks and the oven stops operating if the water reservoir runs out of water during the descaling cycle.

If this happens, refill the reservoir so that the reservoir contains 22 oz (650ml) of drinkable water.

Do not overfill the reservoir. Otherwise, water may leak from the water reservoir.

- Do not cancel descaling while it is in process. If you stop it, you must restart the descaling cycle and complete it within the next three hours to enable the Steam Bake or Steam Roast functions.
- To avoid accidents, keep children away from the oven.
- For the correct ratio of water and the descaling agent, follow the agent manufacturer's instructions. If the ratio of water to descaling agent differs from the instructions here (8 to 1), use the ratio indicated in the instructions for the descaling agent.

## **NOTE**

Although the oven automatically starts descaling in 5 seconds without your confirmation, we recommend that you confirm your selection. This is to prevent descaling from starting by mistake.

## **Draining**

When a steam function is complete, you must drain the remaining water to prevent the water from affecting other cooking modes.

To drain the water, follow these steps:

### 1. Touch Drain.

The oven drains water from the steam generator to the water reservoir.

2. When draining is complete open the oven door, and then touch Reservoir 01 The oven ejects the water reservoir. Use oven gloves to remove and empty the water reservoir.

3. When done, re-insert the reservoir, push it in until there is a soft click, and then touch Reservoir 0 J. The oven retracts the reservoir.

4. Close the oven door.

## **Care and cleaning of the oven**

### **Cleaning painted parts and decorative trim**

- For general cleaning, use a cloth with hot, soapy water.
- For more difficult residue and built-up grease, apply a liquid detergent directly onto the area and leave for 30 to 60 minutes. Wipe with a damp cloth and dry. Do not use abrasive cleaners on any oven surface. They can be scratched.

### **Cleaning stainless steel surfaces**

1. Shake a bottle of Stainless Steel Appliance Cleaner or Polish well.
2. Place a small amount of stainless steel appliance cleaner or polish on a damp cloth or damp paper towel.
3. Clean a small area, rubbing with the grain of the stainless steel if applicable.
4. Dry and buff with a clean, dry paper towel or soft cloth.
5. Repeat as necessary.

### **NOTE**

- Do not use a steel-wool pad. It will scratch the surface.
- If a mineral oil-based stainless steel appliance cleaner has been used before to clean the appliance, wash the surface with dishwashing liquid and water prior to using the Stainless Steel Appliance Cleaner or Polish.

## Oven racks

- If the racks are left in the oven during a self-cleaning cycle, their color will turn slightly blue and the finish will be dull. After the self-cleaning cycle is complete and the oven has cooled, rub the sides of the racks with wax paper or a cloth containing a small amount of oil. This will help the racks glide more easily on their tracks.
- Gliding racks may be cleaned by hand with an abrasive cleaner or steel wool. During cleaning, be careful not to allow water or cleaner to enter the slides on the sides of rack.

### NOTE

- Do not clean in a dishwasher.
- If the rack becomes hard to remove or replace, lightly wipe the oven rack guides with cooking oil. Do not wipe cooking oil on the slides.
- If the rack becomes difficult to slide, the rack may need to be lubricated using a graphite lubricant.

### To lubricate the slides of the gliding rack

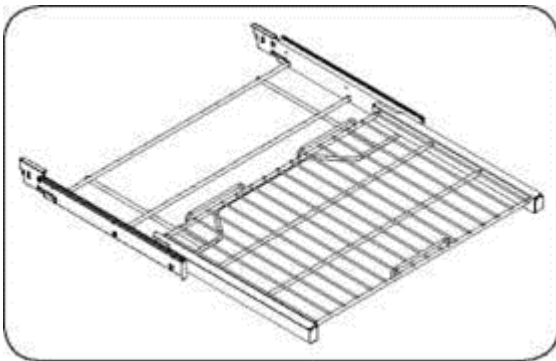

1. Remove the rack from the oven. See removing the gliding rack in the USING THE GLIDING RACK section.
2. Fully extend the rack on a table or countertop. Newspaper may be placed underneath the rack for easy cleanup.

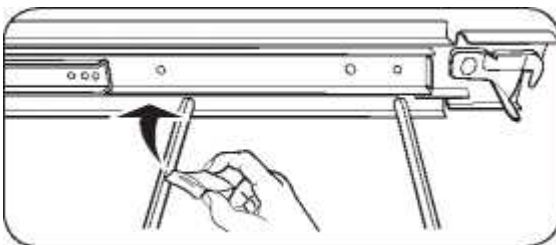

3. If there is debris in the slide tracks, wipe it away using a paper towel. (Any graphite lubricant wiped away must be replaced - See steps 4 through 7.)

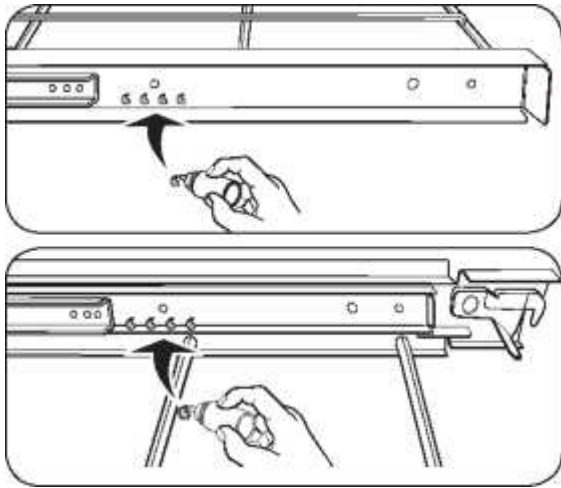

4. Shake the graphite lubricant before opening it. Starting with the left (front and back) slide mechanism of the rack, place four (4) small drops of lubricant on the two (2) bottom tracks of the slide close to the bearing carriers.

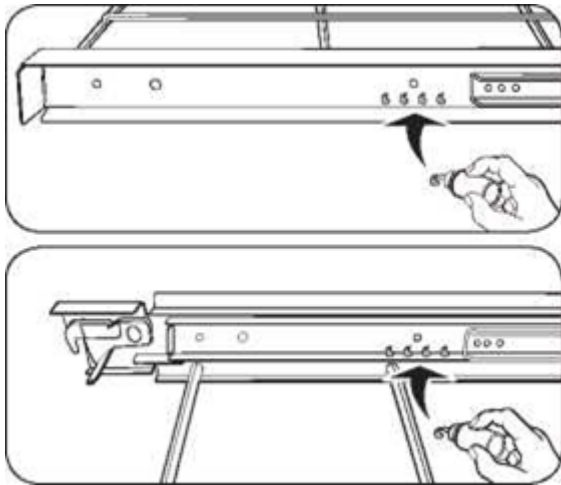

5. Repeat for the right (front and back) slide mechanism of the rack.

6. Open and close the rack several times to distribute the lubricant.

7. Replace the cap on the lubricant and shake it again. Turn the rack over and repeat steps 3, 4, 5 and 6.

8. Close the rack, turn the rack right-side-up, and then place in the oven. See installing the gliding rack in USING THE GLIDING RACK on page 24.

#### NOTE

- Do not spray the gliding rack with cooking spray or other lubricant sprays.

#### Oven door

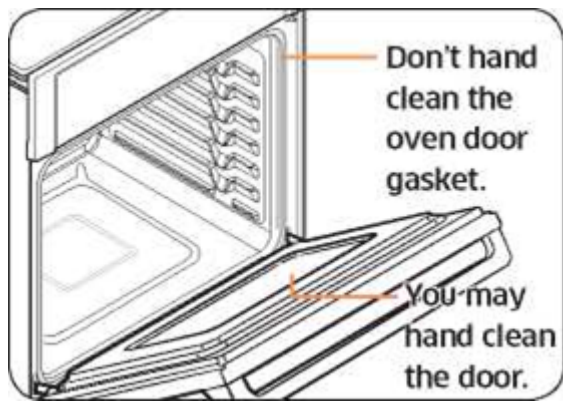

Use soap and water to thoroughly clean the top, sides, and front of the oven door. Rinse well. You may use a glass cleaner on the outside glass of the oven door. DO NOT immerse the door in water. DO NOT spray or allow water or the glass cleaner to enter the door vents. DO NOT use oven cleaners, cleaning powders, or any harsh abrasive cleaning materials on the outside of the oven door.

DO NOT clean the oven door gasket. The oven door gasket is made of a woven material which is essential for a good seal. Care should be taken not to rub, damage, or remove this gasket.

### **Removing the oven doors**

#### **CAUTION**

- The door is very heavy. Be careful when removing and lifting the door.
- Do not lift the door by the handle.

Use two hands to remove an oven door. For double ovens, repeat the process for each door.

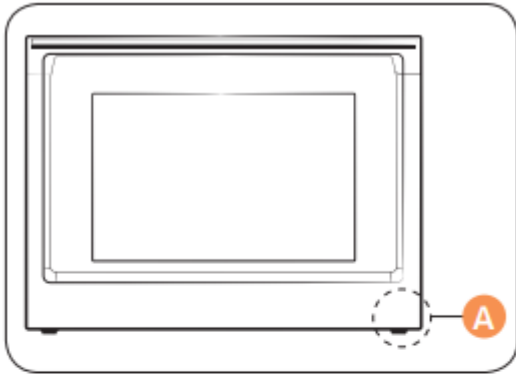

**A.** Wire Harness

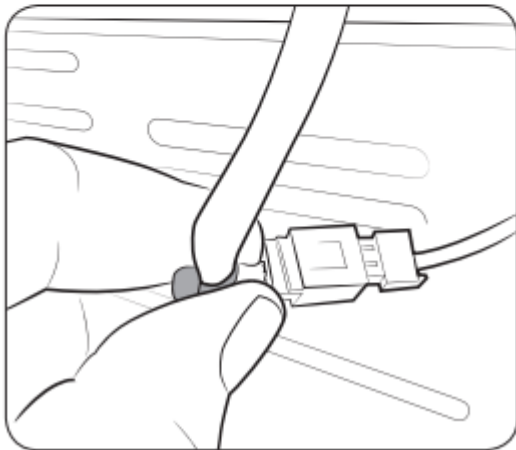

1. Prior to removing the oven door, prepare a surface where you will place it. This surface should be flat and covered with a soft blanket. You can also use the corner posts from your packaging material.
2. Disconnect the LED light's Wire Harness from the bottom right of the door. The wire harness protrudes from slots in the door and in the body of the oven.

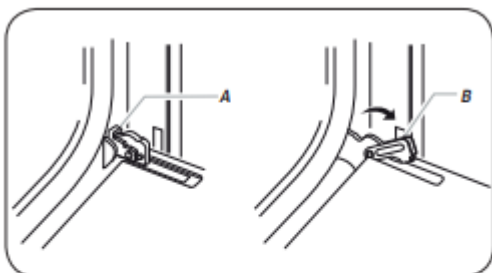

- A.** Oven door hinge lock in locked position
- B.** Oven door hinge lock in unlocked position

3. Open the oven door.

4. Locate the oven door hinge locks in both corners of the oven door, and then rotate the hinge locks toward the oven door to the unlocked position. If the door hinge lock is not rotated fully (see illustration B on the left for an example of full rotation), you will not be able to remove the door properly.

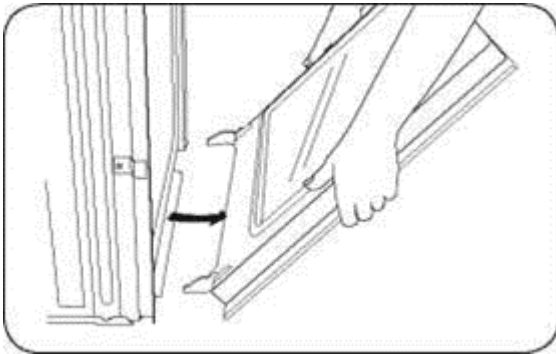
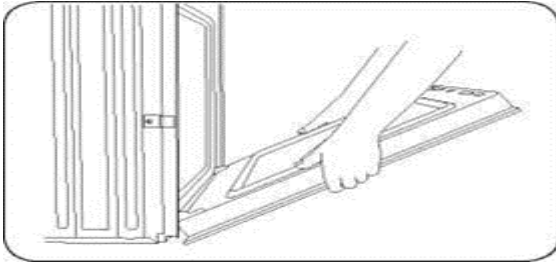

5. Partially close the door to engage the door latch locks.

The door will stop at this point.

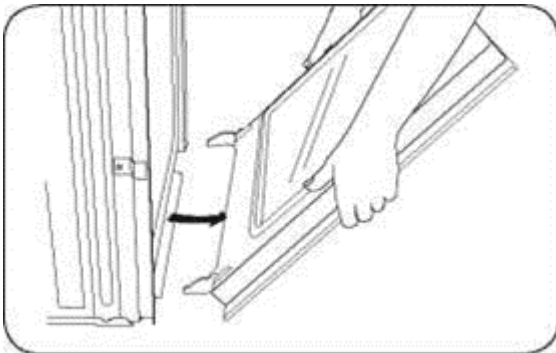

6. Using two hands, grasp the edges of the oven door. Lift and pull the oven door toward you and remove. You may need to gently shift the door from side to side as you pull.

7. Set the oven door aside on the prepared covered work surface with the oven door resting on its handle.

## Replacing the oven doors

### CAUTION

The door is very heavy. You may need help lifting the door high enough to slide it into the hinge slots. Do not lift the door by the handle.

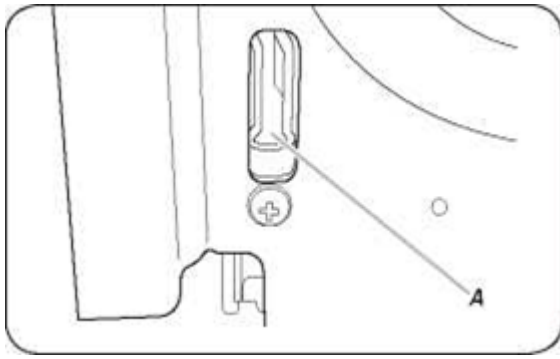

A. Slot in the oven cavity for the door hinge lock

1. Using two hands, grasp the side edges of the door at the midpoint. Face the oven cavity.
2. Locate the slots on each side of the oven cavity for the door hinge locks.

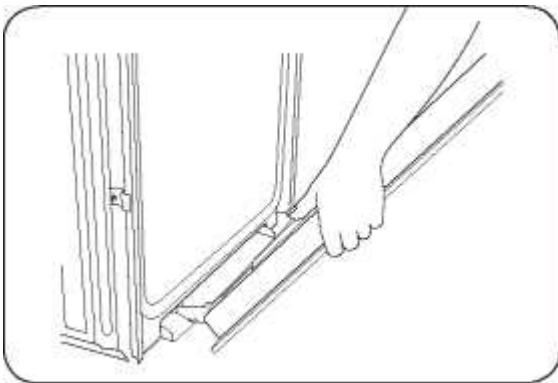

3. Hold the door at a 45° angle, and then align the door hinges with the slots in the lower front of the oven cavity. Slowly insert the door, making sure you maintain the 45° angle. You will know the door is engaged in the slot when you feel a slight drop.

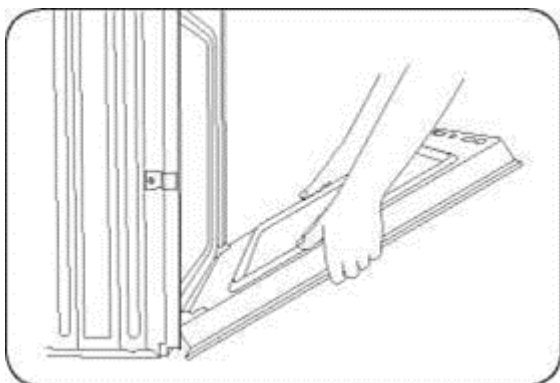

4. Lower the oven door to the fully open position. If the oven door does not open to a full 90°, repeat steps 1 through 3.
5. Locate the oven door hinge locks in the corners of the oven door, and rotate the hinge locks toward the oven cavity to the locked position.

See Step 3 (illustration A) in the “Removing the oven doors” section for the proper locked position.

6. Close the oven door.

7. When the hinges are properly installed and the door is closed, there should be an even gap between the door and the control panel. If one side of the oven door is hanging lower than the other, the hinge on that side is not properly installed.

8. Reconnect the LED light's Wire Harness.

## CAUTION

After replacing the door, make sure to reconnect the wires. Push them inward to arrange them as they were before you removed the door. Wires that are not connected or arranged correctly can be caught in the door or damaged by heat

## Changing the oven light

The oven light is a standard 40-watt appliance halogen bulb. It comes on when the oven door is open. When the oven door is closed, touch  to turn the light on or off. It will not work during a self-cleaning or Hybrid Cleaning cycle.

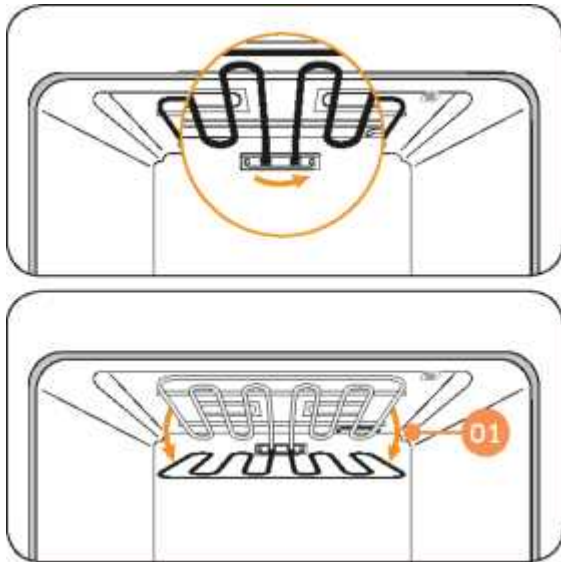

1. To change the halogen bulb, you must tilt the broil heater down. To do this, turn the circular nut on the support counterclockwise while holding the broil heater. The broil heater should loosen and tilt down.

**Important:** The broil heater is not a removable part. Do not force the broil heater down. Do not let it drop down.

2. Remove the glass cover.

3. Remove the halogen bulb cover.

4. Replace the halogen bulb.

5. When done, replace the halogen bulb cover, replace the glass cover, and then follow Step 1 above in the reverse order to return the broiler to its correct position.

**CAUTION**

Before changing your oven light, disconnect the electrical power to the oven at the main fuse or circuit breaker panel. Make sure the oven and the halogen bulb are cool.

## Troubleshooting

**Troubleshooting**

Samsung works hard to ensure that you don't have problems with your new electric oven. If you run into unexpected trouble, look first for a solution in the tables below. If you're still having trouble after trying the suggested solution, call Samsung at 1-800-SAMSUNG (1-800-726-7864).

**CONTROL DISPLAY**

Problem	Possible cause	Solution
The display goes blank.	A fuse in your home may be blown or the circuit breaker tripped.	Replace the fuse or reset the circuit breaker.
The buttons cannot be pressed properly.	<ul style="list-style-type: none"> <li>• There is foreign matter caught between the buttons</li> <li>• Touch model: There is moisture on the exterior</li> <li>• The lock function is set</li> </ul>	<ul style="list-style-type: none"> <li>• Remove the foreign matter and try again.</li> <li>• Remove the moisture and try again.</li> <li>• Check whether the lock function is set.</li> </ul>



## OVEN

Problem	Possible cause	Solution
The oven will not turn on.	The oven is not completely plugged into the electrical outlet.	Make sure the electrical plug is inserted into a live, properly grounded outlet.
	A fuse in your home may be blown or a circuit breaker may have tripped.	Replace the fuse or reset the circuit breaker.
	The oven controls have been set improperly.	See the chapter on operating the oven starting on page 19.
	The oven is too hot.	Allow the oven to cool.
	Incomplete service wiring.	Call for service.
	Power outage.	Check to see if the house lights will turn on. If necessary, call your local electric company for service.
The oven light will not turn on.	The light is loose or defective.	<ul style="list-style-type: none"> <li>• Tighten or replace the lamp.</li> <li>• Call for service if the door light does not turn on.</li> </ul>
	The switch operating the light is broken.	Call for service.

The oven smokes excessively during broiling.	The oven controls have not been set properly.	Refer to the section on operating the oven on page 27.
	The meat has been placed too close to the element.	Reposition the rack to provide proper clearance between the meat and the element. Preheat the broil element for searing.
	The meat has not been properly prepared.	Remove excess fat from the meat. Cut away fatty edges that may curl, leaving the lean intact.
	Grease has built up on oven surfaces.	Regular cleaning is necessary when broiling frequently.
Food does not bake or roast properly.	The oven controls have not been set correctly.	See the chapter on operating the oven starting on page 19.
	The oven rack has been positioned incorrectly or is not level.	See the section on using the oven racks on page 23.
	Incorrect cookware or cookware of improper size is being used.	
	The oven thermistor needs to be adjusted.	See the Temp Adjust section on page 33.



<b>Problem</b>	<b>Possible cause</b>	<b>Solution</b>
Food does not broil properly.	The serving size may not be appropriate.	Refer to the Broiling recommendation guide for serving sizes on page 28, and then try again.
	The rack has not been properly positioned.	See the Broiling recommendation guide on page 28.
	The cookware is not suited for broiling.	Use suitable cookware.
	In some areas, the power (voltage) may be low.	<ul style="list-style-type: none"> <li>• Preheat the broil element for 10 minutes.</li> <li>• See the broiling recommendation guide on page 28.</li> </ul>
The oven temperature is too hot or too cold.	The oven sensor needs to be adjusted.	See the section on adjusting the thermostat on page 33.
There is water dripping.	You may see water or steam in some cases depending on the food you are cooking. This is not a product malfunction.	Let the oven cool and then wipe with a dry dish towel.
There is steam coming through the crack between the oven body and the door.		
Water is remaining in the oven.		

<b>Problem</b>	<b>Possible cause</b>	<b>Solution</b>
I can hear water boiling during steam cooking.	Water is being heated by the steam heater.	This is not a product malfunction.
The oven will not self-clean.	The oven temperature is too high to start a self-clean operation.	Allow the oven to cool and then reset the controls.
	The oven controls have been set incorrectly.	See the section on selfcleaning on page 35.
	A self-cleaning cycle cannot be started if the oven lockout feature has been activated.	Deactivate the oven lockout (see page 35).
Excessive smoking during a self-cleaning cycle.	There is excessive soiling in the oven.	Touch OVEN OFF. Open the windows to rid the room of smoke. Wait until the selfcleaning cycle is cancelled. Wipe up the excessive soil and then start the selfcleaning cycle again.
The oven door will not open after a selfcleaning cycle.	The oven is too hot.	Allow the oven to cool.
The oven is not clean after a self-cleaning cycle.	The oven controls were not set correctly.	See the section on selfcleaning on page 35.
	The oven was heavily soiled.	Wipe up heavy spillovers before starting the selfcleaning cycle. Heavily soiled ovens may need to be self-cleaned again or for a longer period of time.

Steam is coming out of the vent.	When using the convection feature, it is normal to see steam coming out of the oven vent.	This is normal operation and not a system failure.  Use the oven as usual.
	As the number of racks or amount of food being cooked increases, the amount of visible steam will increase.	
A burning or oily odor is coming from the vent.	This is normal for a new oven and will disappear in time.	<ul style="list-style-type: none"> <li>• To speed the process, set a self-cleaning cycle for a minimum of 3 hours.</li> <li>• See the section on selfcleaning on page 35.</li> </ul>
Strong odor.	An odor coming from the insulation around the inside of the oven is normal for the first few times the oven is used.	Operate the oven empty on the bake setting at 400 °F for 1 hour.
Fan noise.	A convection fan may automatically turn on and off.	This is not a system failure but normal operation.
The oven racks are difficult to slide.	The shiny, silver-colored racks were cleaned in a selfcleaning cycle.	Apply a small amount of vegetable oil to a paper towel, and then wipe the edges of the oven racks with the paper towel.
The oven door is locked.	The circuit breaker has been tripped or there was a power failure while the oven door was locked.	Activate Control Lockout, and then unlock the control. See the Control Lockout section on page 21.

## Information codes

### OVEN

Displayed Code	Possible cause	Solution
C-d0	This code occurs if the control key is short for 1 minute.	Clean the buttons and make sure there is no water on/ around them. Turn off the oven and try again. If the problem continues, contact a local Samsung service center.
C-d1	This code occurs if the door lock is mispositioned.	Touch OVEN OFF, and then restart the oven. If the problem persists, disconnect all power to the oven for at least 30 seconds and then reconnect the power. If this does not solve the problem, call for service.
C-F0	This code occurs if communication between the Main and Sub PBA is interrupted.	
C-F2	This code occurs if communication between the Main and Touch is interrupted.	
C-20	The oven sensor is open when the oven is operating.	
	The oven sensor is short when the oven is operating.	

C-21	This code occurs if the internal temperature rises abnormally high.	Touch OVEN OFF, and then restart the oven. If the problem persists, disconnect all power to the oven for at least 30 seconds and then reconnect the power. If this does not solve the problem, call for service.
C-23	The temp probe sensor is short when the oven is operating.	
C-30	The PCB sensor is open when the oven is operating.	
	The PCB sensor is short when the oven is operating.	
C-31	This code occurs if the PCB temperature rises abnormally high.	Call for service
C-70	The Steam sensor is open when the oven is operating.	Touch OVEN OFF, and then restart the oven. If the problem persists, disconnect all power to the oven for at least 30 seconds and then reconnect the power. If this does not solve the problem, call for service.
	The Steam sensor is short when the oven is operating.	
C-72	There are drain system-related problems.	
C-A2	The cooling motor is operating abnormally.	Call for service.

### Warning

This content is compiled from multiple sources and is provided for reference purposes only. It may not be complete or fully applicable to all situations. If you are unable to resolve your issue, please contact the product manufacturer or an authorized service provider for official support.

