

FEATURES AT A GLANCE

Features may vary according to model

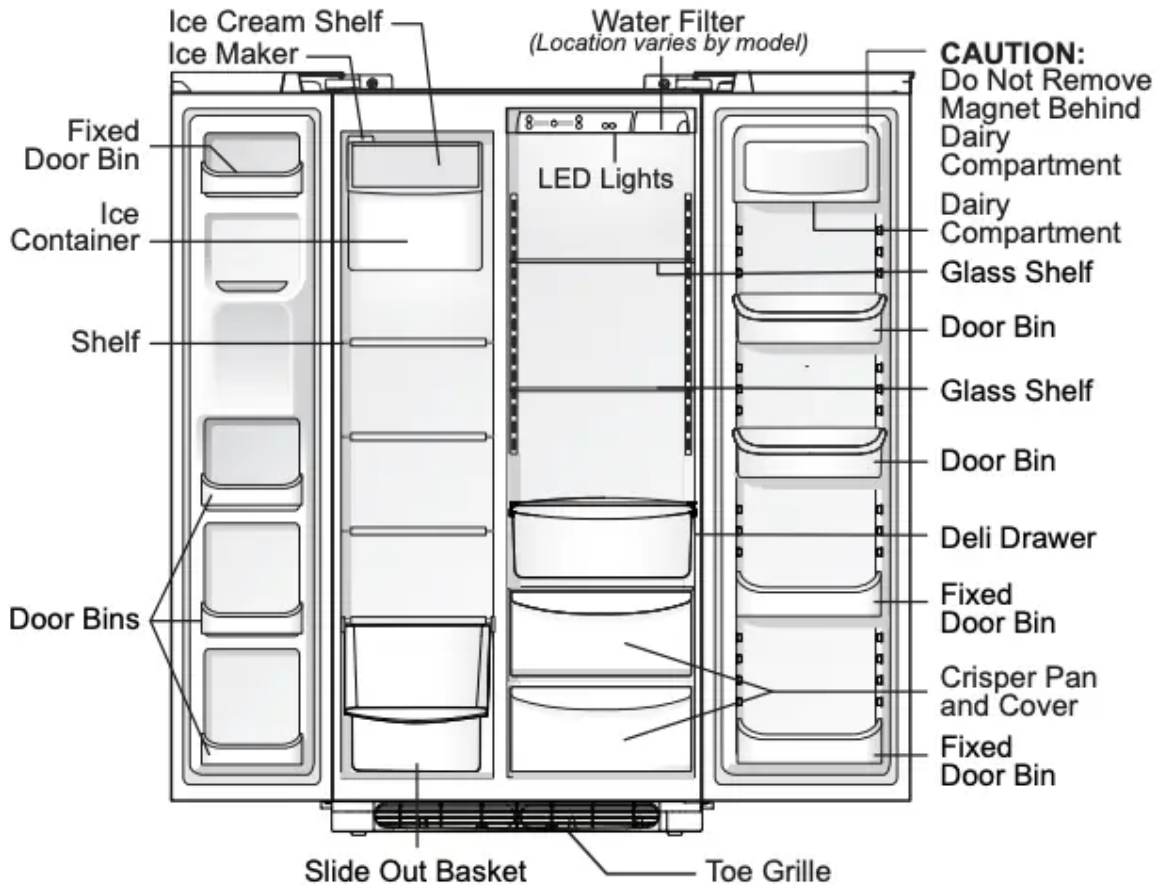

IMPORTANT Features not included with your refrigerator can be purchased at www.frigidaire.com or by calling 1-800-944-9044.

CONTROLS

Allowing Cooling Time Before Use

To ensure safe food storage, allow your refrigerator to operate with the doors closed for at least 8 to 12 hours before placing food inside. During this cooling period, you do not need to adjust the controls, which are preset at the factory.

Setting Cooling Temperatures

NOTE When changing control settings, wait 24 hours for the temperature to stabilize before making additional changes.

Your refrigerator comes with a state-of-the-art electronic digital control system. The system's control panel is located at the top of the refrigerator compartment.

The two digital displays on the left half of the control panel indicate the current settings of your freezer and refrigerator compartments. Should you desire to see what the current accurate temperature is, place a separate thermometer inside the freezer or refrigerator compartment in the desired location.

TEMPERATURE ADJUSTMENT

To adjust the temperature to a higher or lower setting, press the Up (^) or Down (v) button closest to the display. The first time you press the button, the display shows current setting you entered. Each press of the button after that changes the setting by one.

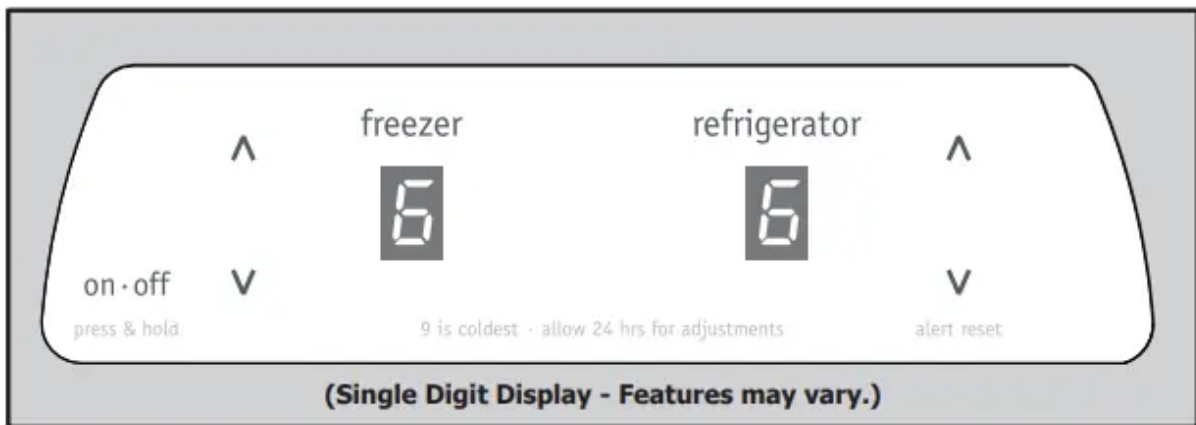

Temperature Adjustmen

If refrigerator compartment is too warm	Adjust refrigerator control one degree colder by pressing up (^) button.
If refrigerator compartment is too cold	Adjust refrigerator control one degree warmer by pressing the down (v) button.
If Freezer compartment is too warm	Adjust Freezer control one degree colder by pressing up (^) button.
If Freezer compartment is too cold	Adjust Freezer control one degree warmer by pressing the down (v) button.

IF TEMPERATURE DISPLAYS FLASH...

If ever you see “OP” or “SH” flashing, it may indicate that the control system has detected a performance problem. Call your service representative, who can interpret the flashing message. To maintain temperatures, a fan circulates air in the refrigerator and freezer compartments. For good circulation, do not block cold air vents with food items.

Numeric Display



	Freezer	Refrigerator
Warmest	1	1
Factory Setting	6	6
Coldest	9	9

ALARMS

Power Fail

In the event of a power failure, the 'power fail' alarm will sound three times. The 'power fail' alarm is an audible alarm only and does not display in the control panel.

High Temperature

When a warm refrigerator is first powered on, the 'power fail' alarm will sound and the current set points will be displayed for a few seconds. After 20 minutes the 'high temp' alarm will sound if the freezer temperature is above 26°F or if the refrigerator temperature is above 55°F (or both are above).

If the unit is above the temperatures mentioned in the paragraph above, the affected compartment temperature display (refrigerator, freezer or both) on the control panel will display 'HI' and an alarm will sound. To disable the alarm press any key on the control panel. After which the control panel will then show the display temperature. The unit will continue to monitor the product temperatures for 'high temp' condition every 20 minutes. If the 'high temp' condition persists, the alarm will sound again and can be reset again. Contact a customer service representative if the high temp alarm continues.

The audible portion of the alarm will silence itself once the product temperature is below 26°F for the freezer temperature and 55°F for the refrigerator temperature. The control panel will still show 'HI' until it is acknowledged by the user by pressing any key on the control panel. After which the control panel will then show the display temperature.

NOTE The advanced electronic control system in your refrigerator includes additional display modes that service professionals can use to rapidly diagnose performance issues.

Turning the Cooling system on and off

You can disable the cooling system in your refrigerator by pressing the On/Off button located on the left side of the temperature control panel. To ensure that you do not accidentally turn off the cooling system, the button does not work unless you press and hold it for three seconds. Once you disable the cooling system, all refrigeration to the freezer and refrigerator compartments stops. To turn the cooling system back on, you must again press and hold the On/Off button for three more seconds. Controls will display OF°F/OF°F when turned off.

NOTE Pressing the On/Off button on the control panel disables your refrigerator's cooling system but does not disconnect power to lights and other electrical components. To turn off power to your

refrigerator you must unplug the power cord from the wall outlet. Each time you make settings on the control panel, a single audible tone acknowledges your input.

STORAGE FEATURES

CAUTION To avoid personal injury or property damage, handle tempered glass shelves carefully. Shelves may break suddenly if nicked, scratched, or exposed to sudden temperature change. Allow the glass shelves to stabilize to room temperature before cleaning. Do not wash in dishwasher.

Glass Shelf Adjustment

Refrigerator shelves are easily adjusted to suit individual needs. Before adjusting the shelves, remove all food. Shelves are supported at the back of the refrigerator.

To adjust shelves:

1. Lift front edge up.
2. Pull shelf out.

Replace the shelf by inserting the hooks at rear of the shelf into the wall bracket. Lower the shelf into the desired slots and lock into position.

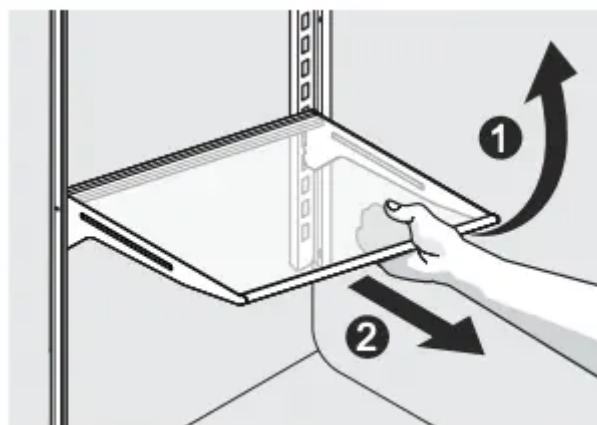

Glass Shelf

Door storage

Door bins and shelves are provided for convenient storage of jars, bottles, and cans. Frequently used items can be quickly selected.

Some models have door bins that can accommodate gallon-sized plastic drink containers and economy-sized jars and containers. Some bins are adjustable for maximum storage capacity.

The dairy compartment, which is warmer than the general food storage section, is intended for short term storage of cheese, spreads, or butter.

Fresh Drawers with Humidity Control (some models)

The fresh drawers, located under the bottom refrigerator shelf, are designed for storing fruits, vegetables, and other fresh produce. The fresh drawers feature humidity control which allows you to adjust the humidity within the drawer. This can extend the life of fresh vegetables that keep best in high humidity. Wash items in clear water and remove excess water before placing them in the crispers. Items with strong odors or high moisture content should be wrapped before storing.

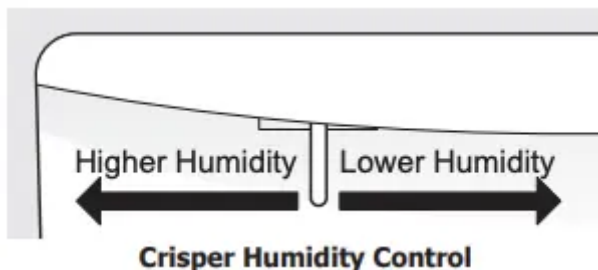

NOTE Leafy vegetables keep best when stored with the humidity control set on Higher Humidity, or in a drawer without a Humidity Control. This keeps incoming air to a minimum and maintains maximum moisture content.

Crispers

Crispers allow you the flexibility to store any manner of items including fruits, vegetables, nuts, etc. Crispers do not feature humidity controls.

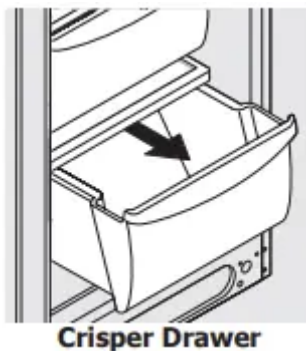

Deli Drawer (some models)

Some models are equipped with a Deli Drawer for storage of luncheon meats, spreads, cheeses and other deli items. This drawer does not have a separate temperature control.

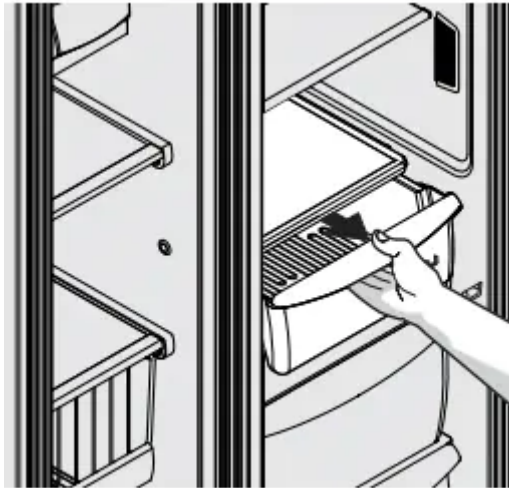

AUTOMATIC ICE & WATER DISPENSER

NOTE Your refrigerator may have some or all of the features listed below. Become familiar with these features and their use and care.



CUBE	Press the CUBE Touch Pad to get cubed ice. A green light will appear above the Touch Pad. Press glass against ICE dispensing paddle as far up as possible to catch all ice.
CRUSH	Press the CRUSH Touch Pad to get crushed ice. A green light will appear above the Touch Pad. Press glass against ICE dispensing paddle as far up as possible to catch all ice.
LIGHT	Press the LIGHT Touch Pad to turn on dispenser light. Press again to turn the light off. The light also turns on automatically when ice and/or water is dispensed. Replace light bulb with an appliance bulb of the same wattage.
FILTER STATUS	<p>The FILTER STATUS indicator light above the Touch Pad will light up each time the dispenser is used. The following filter light indications are:</p> <p>Green: The filter is still operating within its specified life cycle.</p> <p>Amber: The filter has reached approximately 80 percent of its useful life. This is the recommended time to purchase a replacement filter.</p> <p>Red: The filter is 100 percent used up. Change the filter as soon as possible.</p> <p>After the filter cartridge has been changed, press and hold the FILTER RESET Touch Pad for 10-15 seconds.</p> <p>NOTE: The Green, Amber and Red lights will flash when reset is completed.</p>
LOCK	<p>The Ice & Water Dispenser can be locked out to prevent unwanted use.</p> <p>To Lock Out: Press the LOCK Touch Pad for 3-5 seconds. A red light will appear above the Touch Pad.</p> <p>To Unlock: Press the LOCK Touch Pad for 3-5 seconds until the red light above the Touch Pad goes out.</p>
WATER	To operate the water dispenser, press a glass against the WATER dispensing paddle. To stop dispensing water, pull the glass away from the dispensing paddle. Dispensed water is not cold. For colder water, add crushed ice or cubes before dispensing water. A drip tray located at the base of the dispenser catches small spills and allows them to evaporate. This drip tray is removable and dishwasher safe. Do not pour water and excess ice in this area because there is no drain.

NOTE Your refrigerator may have some or all of the features listed below. Become familiar with these features and their use and care.

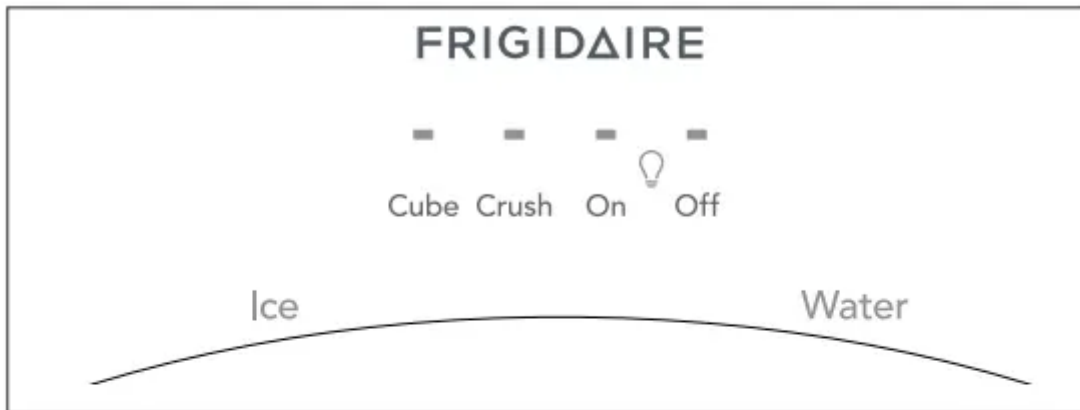

Crush	Press the Crush Touch Pad to get crushed ice. A red indicator will appear above the Touch Pad. Press glass against ICE dispensing paddle as far up as possible to catch all ice.
Cube	Press the Cube Touch Pad to get cubed ice. A red indicator will appear above the Touch Pad. Press glass against ICE dispensing paddle as far up as possible to catch all ice.
Light On	Press the Light On Touch Pad to turn on dispenser light. A red indicator will appear above the Touch Pad.
Light Off	Press the Light Off Touch Pad to turn off dispenser light. A red indicator will appear above the Touch Pad.
Water	To operate the water dispenser, press a glass against the WATER dispensing paddle. To stop dispensing water, pull the glass away from the dispensing paddle. Dispensed water is not cold. For colder water, add crushed ice or cubes before dispensing water. A drip tray located at the base of the dispenser catches small spills and allows them to evaporate. This drip tray is removable and dishwasher safe. Do not pour water and excess ice in this area because there is no drain.

Priming the Water Supply System

Your refrigerator's water supply system includes several tubing lines, an advanced water filter, a distribution valve bank, and a reserve tank (some models) to ensure ample supply to the ice and water dispenser at all times. This system needs to be completely filled with water when first connected to an external supply line.

CAUTION For proper dispenser operation, recommended water supply pressure should fall between 30 psi and 100 psi. Excessive pressure may cause water filter to malfunction.

To prime the water supply system:

1. Begin by pressing and holding a drinking glass against the water dispenser paddle.
2. Keep the glass in this position until water comes out of the dispenser. It may take about 1½ minutes.
3. Continue dispensing water for about four minutes to flush the system and plumbing connections of any impurities (stopping to empty the glass as necessary).

NOTE The water dispenser has a built-in device that shuts off the water flow after three minutes of continuous use. To reset this shutoff device, simply release the dispenser paddle.

Ice Maker Operation & Care

The ice maker, ice bin, and dispenser feeding mechanism are located in the top of the freezer compartment. After the refrigerator is installed properly and has cooled for several hours, the ice maker can produce ice within 24 hours. It can completely fill an ice bin in about two days.

Ice Production: What to Expect

How Much Ice Will a Side Mounted Ice Maker Produce in 24 Hours?

A side mounted ice maker will produce 4 to 4.5 pounds of ice every 24 hours, depending on usage conditions. Ice is produced at a rate of 8 cubes every 75 to 90 minutes.

Using the Ice Maker after Installation

Before making ice for the first time, be sure to prime the water supply system. Air in new plumbing lines can result in two or three empty ice maker cycles. Furthermore, if the system is not flushed, the first ice cubes may be discolored or have an odd flavor.

IMPORTANT Your ice maker is shipped from the factory with the wire signal arm in the ON position. To ensure proper function of your ice maker, hook up water supply immediately or turn ice maker OFF by lifting the wire signal arm until it clicks and locks in the UP position (side mounted). If the ice maker is not turned off and the water supply is not connected, the water valve will make a loud chattering noise.

Turning the SIDE MOUNTED Ice Maker On and Off

To begin ice production, lower the wire signal arm to the DOWN or ON position. The ice maker turns off automatically when the ice container becomes full. To stop the ice maker, raise the wire signal arm until it clicks and locks in the UP or OFF position.

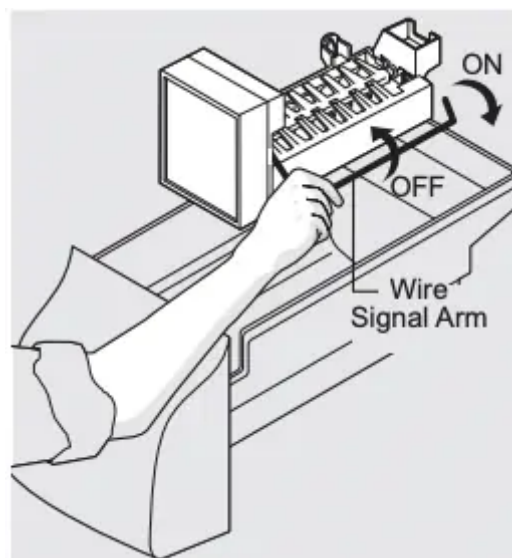

IMPORTANT Small ice cubes or ice chips jamming in the ice maker may be a sign that your water filter needs changing. If you have a side mounted ice maker you may also experience hollow

cubes partially frozen cubes with water inside. When these cubes are harvested, they break open and spill water over the other ice cubes in the ice container, forming a solid mass of ice. As the water filter nears the end of its useful life and becomes clogged with particles, less water is delivered to the ice maker during each cycle. The ice maker can't fill every cube in the ice maker mold, leading to small cubes or chips that can get caught between the ice ejector blades and the stripper. Remember, if your ice maker is jamming with small ice cubes or it's been six months or longer since you last changed your water filter replace the water filter with a new one. Poor quality household water may require the filter to be changed more frequently.

Ice Maker/Dispenser Tips

- Ice cubes stored too long may develop an odd flavor. Empty the ice container as explained below.
- Occasionally shake the ice container to keep ice separated.
- If your refrigerator is not connected to a water supply or the water supply is turned off, turn Off the ice maker.
- If you need a large quantity of ice at one time, it is best to get cubes directly from the ice container.
- The following sounds are normal when the ice maker is operating:
 - Motor running
 - Ice dropping into ice container
 - Water valve opening or closing
 - Ice loosening from tray
 - Running water
- When dispensing ice, you will hear a snapping or clicking sound when the ice chute opens and closes.
- Turn Off the ice maker when cleaning the freezer and during vacations.
- If you turn Off the ice maker for a long period of time, you should also turn off the water supply valve.

CAUTION Chemicals from a malfunctioning water softener can damage the ice maker. If the water supply to your refrigerator is softened, be sure the softener is maintained to work properly

Cleaning the Ice Maker

Clean the ice maker and ice bin at regular intervals, particularly before you take a vacation or move.

To clean the ice maker:

1. Turn Off the ice maker.
2. Remove the ice bin by lifting up and out.
3. Empty and carefully clean the ice bin with mild detergent. Rinse with clear water. Do not use harsh or abrasive cleaners.
4. Allow the ice bin to dry completely before replacing in the freezer.
5. Remove ice chips and clean the ice bin shelf and the freezer door chute.
6. Replace the ice bin. Turn On the ice maker to resume ice production.

Remove and empty the ice storage bin if:

- An extended power failure (one hour or longer) causes ice cubes in the ice storage bin to melt and freeze together, jamming the dispenser mechanism.
- You do not use the ice dispenser frequently. Ice cubes will freeze together in the bin, jamming the dispenser mechanism.

Remove the ice storage bin and shake to loosen the cubes or clean as explained above.

CAUTION NEVER use an ice pick or similar sharp instrument to break up the ice. This could damage the ice storage bin and dispenser mechanism.

IMPORTANT When removing or replacing the ice bin, DO NOT rotate the auger in the ice bin. If the auger is accidentally rotated, you must realign the auger by turning it in 90 degree turns (see below) until the ice bin fits into place with the drive mechanism. If the auger is not properly aligned when replacing the ice bin, the refrigerator will only dispense Crushed Ice. The freezer door may also not close properly causing warm air to leak into the freezer.

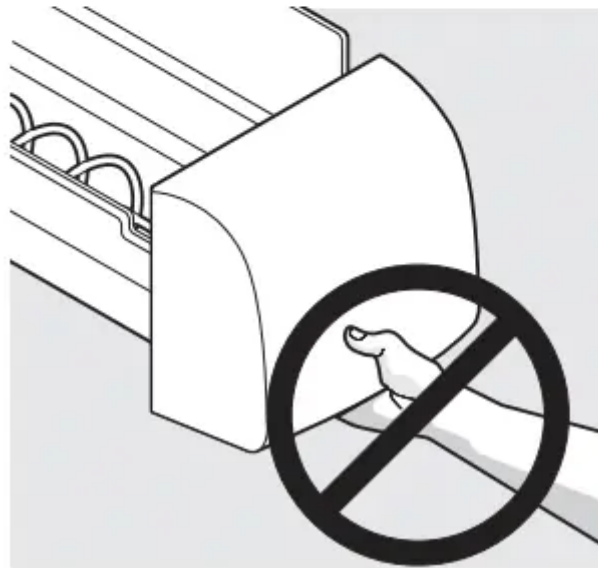
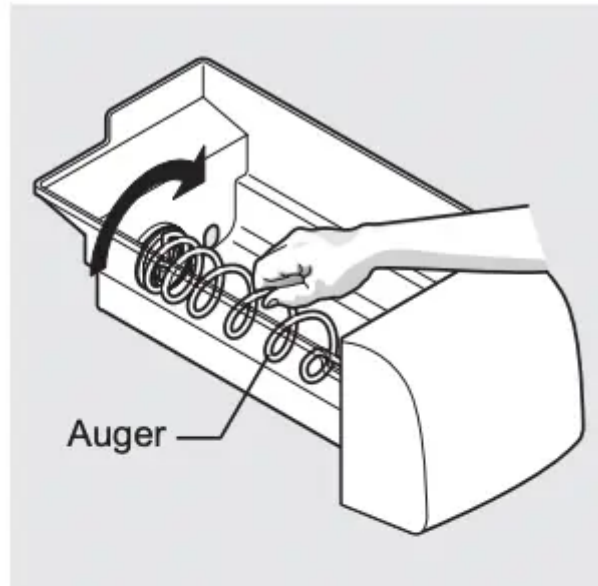

CHANGING THE FILTER

Locating the Filter

Your refrigerator is equipped with a water filtering system. The water filter system filters all dispensed drinking water, as well as the water used to produce ice.

Water Filter

The water filter is located at the top right side of the refrigerator compartment.

Replacing the Water Filter

In general, you should change the water filter every six months to ensure the highest possible water quality. Water Filter Status on the user interface prompts you to replace the filter after a

standard amount of water (200 gallons/757 liters for PureSource Ultra™ and PureSource 3™) has flowed through the system.

If your refrigerator has not been used for a period of time (during moving for example), change the filter before reinstalling the refrigerator.

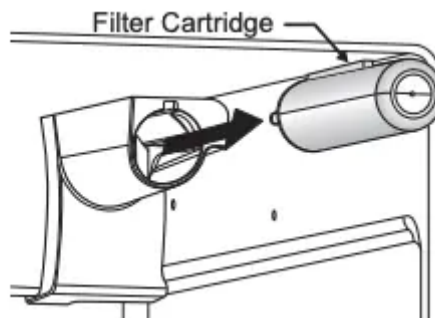

NOTE If your refrigerator is equipped with a PureSource 3™ water filter, it can be replaced with a PureSource Ultra™ water filter. Replacing your PureSource 3™ water filter with a PureSource Ultra™ water filter removes more potential contaminants as tested by NSF. The contaminants or other substances removed or reduced by this water filter are not necessarily in all users' water

Ordering Replacement Filters

To order your replacement filters, please visit our online store at www.frigidaire.com/store, by calling toll-free at 877-808-4195, or by visiting the dealer where you purchased your refrigerator. Frigidaire recommends that you order extra filters when you first install your refrigerator, and that you replace your filters at least once every six months.

Here are the product numbers to request when ordering:

PureSource Ultra™ Water Filter

Part# ULTRAWF

PureSource 3™ Water Filter

Part #WF3CB

NOTE If your refrigerator is equipped with a PureSource Ultra™ water filter, it must be replaced with PureSource Ultra™ water filter ULTRAWF.

Test & certification results:

- Rated Capacity - 200 gallons/757 liters for PureSource Ultra™ and PureSource 3™ ice and water filter
- Rated service flow - .50 gallons per minute
- Operating Temp.: Min. 33°F, Max. 100°F
- Maximum Rated Pressure - 100 pounds per square inch
- Recommended Minimum Operating Pressure: 30 pounds per square inch

To replace your PureSource 3™ water filter:

It is not necessary to turn the water supply off to change the filter. Be ready to wipe up any small amounts of water released during the filter replacement.

1. Turn Off the ice maker.
2. Remove the filter by pushing on the end/face of the filter.
3. Slide the old water filter cartridge straight out of the housing and discard it.
4. Unpackage the new filter cartridge. Using the alignment guide, slide it gently into the filter housing until it stops against the snap-in connector at the back of the housing.
5. Push firmly until the cartridge snaps into place (you should hear a click as the cartridge engages the snap-in connector).
6. Press a drinking glass against the water dispenser while checking for any leaks at the filter housing. Any spurts and sputters that occur as the system purges air out of the dispenser system are normal.
7. After filling one glass of water, continue flushing the system for about four minutes.
8. Turn On the ice maker.
9. Press and hold the Water Filter button on the Ice & Water Dispenser control panel for three seconds. When the display changes from "Red" to "Green," the status has been reset.

NORMAL OPERATING SOUNDS AND SIGHTS

Understanding the Sounds you may Hear

Your new, high-efficiency refrigerator may introduce unfamiliar sounds. These sounds normally indicate your refrigerator is operating correctly. Some surfaces on floors, walls, and kitchen cabinets may make these sounds more noticeable.

Following is a list of major components in your refrigerator and the sounds they can cause:

A Evaporator Refrigerant through the evaporator may create a boiling or gurgling sound.

B Evaporator fan You may hear air being forced through the refrigerator by the evaporator fan.

C Defrost heater During defrost cycles, water dripping onto the defrost heater may cause a hissing or sizzling sound. After defrosting, a popping sound may occur.

D Automatic ice maker When ice has been produced, you will hear ice cubes falling into the ice bin.

E Automatic defrost control These parts can produce a snapping or clicking sound when turning the cooling system on and off.

F Condenser fan You may hear air being forced through the condenser.

G Compressor Modern, high-efficiency compressors run much faster than in the past. The compressor may have a highpitched hum or pulsating sound.

H Water valve Makes a buzzing sound each time it opens to fill the ice maker.

I Drain pan (not removable) You may hear water dripping into the drain pan during the defrost cycle.

J Condenser May create minimal sounds from forced air.

K Motorized damper May produce a light humming during operation.

L Ice chute When dispensing ice, you will hear a snapping or clicking sound when the solenoid opens and closes the ice chute.

NOTE Energy efficient foam in your refrigerator is not a sound insulator.

NOTE During automatic defrost cycle, a red glow in the back wall vents of your freezer compartment is normal.

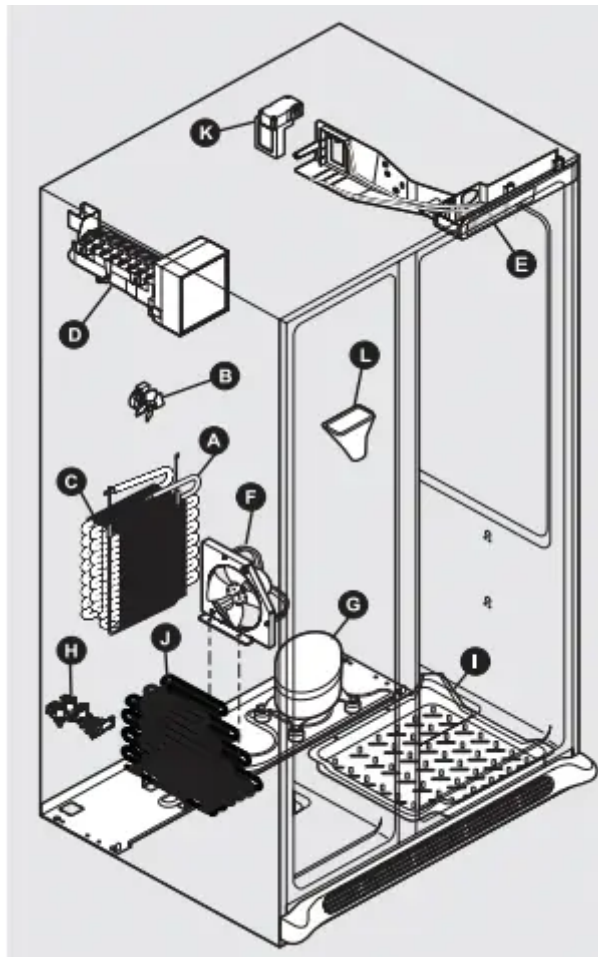

CARE & CLEANING

Protecting your investment

Keeping your refrigerator clean maintains appearance and prevents odor build-up. Wipe up any spills immediately and clean the freezer and refrigerator compartments at least twice a year.

When cleaning, take the following precautions:

- Never use CHLORIDE or cleaners with bleach to clean stainless steel.
- Do not wash any removable parts in a dishwasher.
- Always unplug the electrical power cord from the wall outlet before cleaning.
- Remove adhesive labels by hand. Do not use razor blades or other sharp instruments which can scratch the appliance surface.
- Do not remove the serial plate.

Do not use abrasive cleaners such as window sprays, scouring cleansers, brushes, flammable fluids, cleaning waxes, concentrated detergents, bleaches or cleansers containing petroleum products on plastic parts, interior doors, gaskets or cabinet liners. Do not use paper towels, metallic scouring pads, or other abrasive cleaning materials or strong alkaline solutions.

NOTE If you set your temperature controls to turn off cooling, power to lights and other electrical components will continue until you unplug the power cord from the wall outlet.

CAUTION

- Pull the refrigerator straight out to move it. Shifting it from side to side may damage flooring. Be careful not to move the refrigerator beyond the plumbing connections.
- Damp objects stick to cold metal surfaces. Do not touch refrigerated surfaces with wet or damp hands.
- Sudden temperature changes can cause glass breakage.

IMPORTANT If you store or move your refrigerator in freezing temperatures, be sure to completely drain the water supply system. Failure to do so could result in water leaks when the refrigerator is put back into service. Contact a service representative to perform this operation.

Care & Cleaning Tips



Part	What To Use	Tips and Precautions
Interior & Door Liners	<ul style="list-style-type: none"> • Soap and water • Baking soda and water 	Use two tablespoons of baking soda in one quart of warm water. Be sure to wring excess water out of sponge or cloth before cleaning around controls, light bulb or any electrical part.
Door Gaskets	<ul style="list-style-type: none"> • Soap and water 	Wipe gaskets with a clean soft cloth
Drawers & Bins	<ul style="list-style-type: none"> • Soap and water 	Use a soft cloth to clean drawer runners and tracks.
Glass Shelves	<ul style="list-style-type: none"> • Soap and water • Glass cleaner • Mild liquid sprays 	Allow glass to warm to room temperature before immersing in warm water.
Toe Grille	<ul style="list-style-type: none"> • Soap and water • Mild liquid sprays • Vacuum attachment 	Vacuum dust from front of toe grille. Remove toe grille (see Installation Instructions). Vacuum backside, wipe with sudsy cloth or sponge. Rinse and dry.
Exterior & Handles	<ul style="list-style-type: none"> • Soap and water • Non Abrasive Glass Cleaner 	Do not use commercial household cleaners containing ammonia, bleach or alcohol to clean handles. Use a soft cloth to clean smooth handles. DO NOT use a dry cloth to clean smooth doors.
Exterior & Handles (Stainless	<ul style="list-style-type: none"> • Soap and water 	Never use CHLORIDE or cleaners with bleach to clean stainless steel. Clean stainless steel front and

<p>Steel Models Only)</p>	<ul style="list-style-type: none"> • Stainless Steel Cleaners 	<p>handles with non-abrasive soapy water and a dishcloth. Rinse with clean water and a soft cloth. Use a non-abrasive stainless steel cleaner. These cleaners can be purchased at most home improvement or major department stores. Always follow manufacturer's instructions. Do not use household cleaners containing ammonia or bleach.</p> <p>NOTE: Always clean, wipe and dry with the grain to prevent scratching. Wash the rest of the cabinet with warm water and mild liquid detergent. Rinse well, and wipe dry with a clean soft cloth.</p>
<p>Replacing LED Bulbs</p>	<ul style="list-style-type: none"> • Unplug refrigerator • Wear gloves • Remove light cover • Replace old LED bulb • Replace light cover • Plug in the refrigerator 	<p>CAUTION: Wear gloves when replacing LED bulbs to avoid getting cut. Use same wattage when replacing LED bulb.</p>



BEFORE YOU CALL

CONCERN	CAUSE	SOLUTION
AUTOMATIC ICE MAKER		
<p>Ice maker is not making any ice.</p>	<ul style="list-style-type: none"> • Ice maker wire signal arm is in the “up” or OFF position. • Ice maker has small cube caught in mechanism. • Saddle valve on cold water pipe is clogged or restricted by foreign material. 	<ul style="list-style-type: none"> • Move wire signal arm to the “down” or ON position (side mounted). • Remove small cube from ice maker. The ice and water filter cartridge may be clogged. Replace filter cartridge. • Turn off household water line valve. Remove valve. Ensure that valve is not a self-piercing saddle valve. Clean valve. Replace valve if necessary



<p>Ice maker is not making enough ice.</p>	<ul style="list-style-type: none"> • Ice maker is producing less ice than you expect. • Check to see if water dispenser is dispensing slower than normal. • Freezer control is set too warm. 	<ul style="list-style-type: none"> • Side mounted ice maker should produce 4 to 4.5 pounds (approximately 4 quarts) of ice every 24 hours. • If it is, replace the ice and water filter cartridge. • Set freezer control to colder setting to improve performance of the ice maker. Allow 24 hours for temperature to stabilize.
<p>Ice maker will not stop making ice.</p>	<ul style="list-style-type: none"> • Ice maker wire signal arm is being held down by some item in the freezer. 	<ul style="list-style-type: none"> • Move item and release wire signal arm. Remove any ice cubes that are frozen together over the wire signal arm.
<p>Ice cubes are freezing together.</p>	<ul style="list-style-type: none"> • Ice cubes are not being used frequently enough. • Ice cubes are hollow (partially frozen cubes with water inside). • Freezer control is set too warm. 	<ul style="list-style-type: none"> • Remove ice container and discard ice from container. Ice maker will produce fresh supply. • The ice and water filter cartridge may be clogged. Replace filter cartridge. • Set freezer control to colder setting. Allow 24 hours for



		temperature to stabilize.
DISPENSER (Ice & Water)		
Dispenser will not dispense ice.	<ul style="list-style-type: none"> • Dispenser lock out is engaged. • There is no ice in the bin to be dispensed. • The refrigerator doors are not completely closed. • Dispenser paddle has been pressed too long and the dispenser motor has overheated. 	<ul style="list-style-type: none"> • Press and hold control lock for three seconds. • See the “Ice maker is not making any ice” section above. • Be sure the refrigerator doors are completely closed. • The motor overload protector will reset in about three minutes and then ice can be dispensed.
Ice dispenser is jammed.	<ul style="list-style-type: none"> • Ice has melted and frozen around auger due to infrequent use, temperature fluctuations, and/or power outages. • Ice cubes are jammed between ice maker and back of ice container. 	<ul style="list-style-type: none"> • Remove ice container, thaw, and empty the contents. Clean container, wipe dry, and replace in proper position. When new ice is made, dispenser should operate. • Remove ice cubes that are jamming the dispenser.
Dispenser will not dispense water.	<ul style="list-style-type: none"> • Dispenser lock out is engaged. • Water filter not seated properly. • Water filter is clogged. 	<ul style="list-style-type: none"> • Press and hold control lock for three seconds. • Remove and reinstall the water



	<ul style="list-style-type: none"> • Household water line valve is not open. 	<p>filter. Be sure to push the filter firmly so that you hear it lock solidly into position.</p> <ul style="list-style-type: none"> • Replace filter cartridge. Be sure to remove protective caps and push the filter firmly so that you hear it lock solidly into position. • Open household water line valve. See CONCERN column AUTOMATIC ICE MAKER.
<p>Water has an odd taste and/or odor.</p>	<ul style="list-style-type: none"> • Water has not been dispensed for an extended period of time. • Unit not properly connected to cold water line. 	<ul style="list-style-type: none"> • Draw and discard 10-12 glasses of water to freshen the supply. • Connect unit to cold water line that supplies water to the kitchen faucet.
<p>Water pressure is extremely low.</p>	<ul style="list-style-type: none"> • Cut-off and cut-on pressures are too low (well systems only). • Reverse osmosis system is in regenerative phase. 	<ul style="list-style-type: none"> • Have someone turn up the cut-off and cut-on pressure on the water pump system (well systems only). • It is normal for a reverse osmosis system to be below 20 psi during the regenerative phase.



<p>Water not cold enough.</p>	<ul style="list-style-type: none"> • As warmer tap water goes through the filter and enters the water tank the chilled water is pushed through to the dispenser. Once the chilled water is used up it will take several hours to bring the freshly replaced water to a cooler temperature. • Some models are designed without a water tank, these water dispensing systems are not designed to chill water 	<ul style="list-style-type: none"> • Add ice to cup or container before dispensing water. • Add ice to cup or container before dispensing water
<p>OPENING/CLOSING OF DOORS/DRAWERS</p>		
<p>Door(s) will not close.</p>	<ul style="list-style-type: none"> • Door was closed too hard, causing other door to open slightly. • Refrigerator is not level. It rocks on the floor when moved slightly. • Refrigerator is touching a wall or cabinet. 	<ul style="list-style-type: none"> • Close both doors gently. • Ensure floor is level and solid, and can adequately support the refrigerator. Contact a carpenter to correct a sagging or sloping floor. • Ensure floor is level and solid, and can adequately support the refrigerator. Contact a carpenter to correct a sagging or sloping floor
	<ul style="list-style-type: none"> • Food is touching shelf on top of drawer. 	<ul style="list-style-type: none"> • Remove top layer of items in drawer.



<p>Drawers are difficult to move.</p>	<ul style="list-style-type: none"> • Track that drawers slide on is dirty. 	<ul style="list-style-type: none"> • Ensure drawer is properly installed on track. • Clean drawer, rollers, and track. See Care & Cleaning.
<p>RUNNING OF REFRIGERATOR</p>		
<p>Compressor does not run.</p>	<ul style="list-style-type: none"> • Freezer control is set to "OF" or "0". • Refrigerator is in defrost cycle. • Plug at electrical outlet is disconnected. • House fuse blown or tripped circuit breaker. • Power outage. 	<ul style="list-style-type: none"> • Set freezer control. • This is normal for a fully automatic defrost refrigerator. The defrost cycle occurs periodically, lasting about 30 minutes. • Ensure plug is tightly pushed into outlet. • Check/replace fuse with a 15 amp timedelay fuse. Reset circuit breaker. • Check house lights. Call local electric company.
<p>Refrigerator runs too much or too long.</p>	<ul style="list-style-type: none"> • Room or outside weather is hot. • Doors are opened too frequently or too long. • Refrigerator/freezer door may be slightly open. • Freezer control is set too cold. 	<ul style="list-style-type: none"> • It's normal for the refrigerator to work longer under these conditions. • Warm air entering the refrigerator causes it to run more. Open doors less often.



	<ul style="list-style-type: none"> • Refrigerator/freezer gasket is dirty, worn, cracked, or poorly fitted. • Condenser is dirty 	<ul style="list-style-type: none"> • Ensure refrigerator is level. Keep food and contents from blocking door. See PROBLEM column OPENING/ CLOSING OF DOORS/ DRAWERS. • Set Refrigerator control to warmer setting until refrigerator temperature is satisfactory. Allow 24 hours for temperature to stabilize. • Clean or change gasket. Leaks in door seal will cause refrigerator to run longer in order to maintain desired temperatures. • Clean condenser. See Care & Cleaning.
Compressor goes off and on frequently	<ul style="list-style-type: none"> • Thermostat keeps the refrigerator at a constant temperature. 	<ul style="list-style-type: none"> • This is normal. Refrigerator goes on and off to keep temperature constant.
DIGITAL TEMPERATURE DISPLAY		
Digital temperature displays are flashing.	<ul style="list-style-type: none"> • Electronic control system has detected a performance problem. 	<ul style="list-style-type: none"> • Call your Frigidaire service representative, who can interpret any



		messages or number codes flashing on the digital displays.
WATER/MOISTURE/FROST INSIDE REFRIGERATOR		
Moisture collects on inside of refrigerator walls.	<ul style="list-style-type: none"> • Weather is hot and humid. • Door is slightly open. 	<ul style="list-style-type: none"> • The rate of frost buildup and internal sweating increases. • See PROBLEM column OPENING/ CLOSING OF DOORS/ DRAWERS.
Water collects on bottom side of drawer cover.	<ul style="list-style-type: none"> • Vegetables contain and give off moisture. 	<ul style="list-style-type: none"> • It is not unusual to have moisture on the bottom side of the cover. • Move humidity control (some models) to lower setting.
Water collects in bottom of drawer.	<ul style="list-style-type: none"> • Washed vegetables and fruit drain while in the drawer 	<ul style="list-style-type: none"> • Dry items before putting them in the drawer. Water collecting in bottom of drawer is normal.
WATER/MOISTURE/FROST OUTSIDE REFRIGERATOR		
Moisture collects on outside of refrigerator or between doors.	<ul style="list-style-type: none"> • Weather is humid. • Door is slightly open, causing cold air from inside refrigerator to meet warm air from outside. 	<ul style="list-style-type: none"> • This is normal in humid weather. When humidity is lower, the moisture should disappear. • See PROBLEM column OPENING/

		CLOSING OF DOORS/ DRAWERS.
--	--	----------------------------------

Warning

This content is compiled from multiple sources and is provided for reference purposes only. It may not be complete or fully applicable to all situations. If you are unable to resolve your issue, please contact the product manufacturer or an authorized service provider for official support.

