

USING THE WASHER

Getting started

▲ WARNING To reduce the risk of fire, electric shock, or injury to persons, read the **IMPORTANT SAFETY** before operating this appliance

Throughout this manual, features and appearance may vary from your model.

Step 1

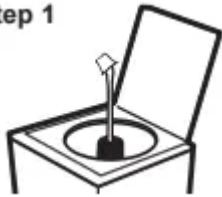

- Add fabric softener to the fabric softener dispenser (on some models); see page 14.
- If using detergent packets, add to the bottom of the wash basket before adding clothes.

Step 2



- Loosely add items around agitator or Infusor. Overloading may negatively impact wash performance. See page 15 for suggested loading examples.
- Add the manufacturer's recommended amount of detergent to the top of the load after adding clothes. We recommend the use of High Efficiency detergents such as in your energy efficient washer.

Step 3



- Close lid.
- **NOTE:** Unit will not start with lid open if Precise Fill is selected except on Bulky Items cycle.
- Select wash cycle.

- Select wash options, including Deep Rinse option (on some models) when using fabric softener.
- Select options.
- Select load size (on some models).

Step 4



- Press Start.

Controls

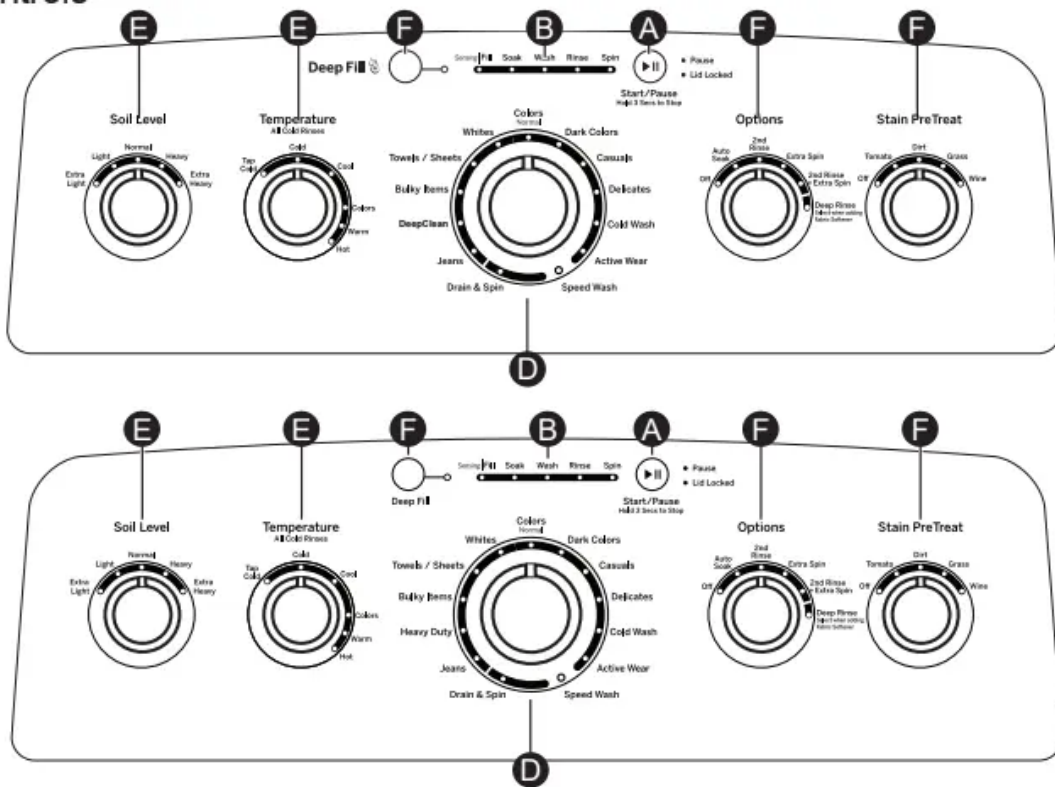

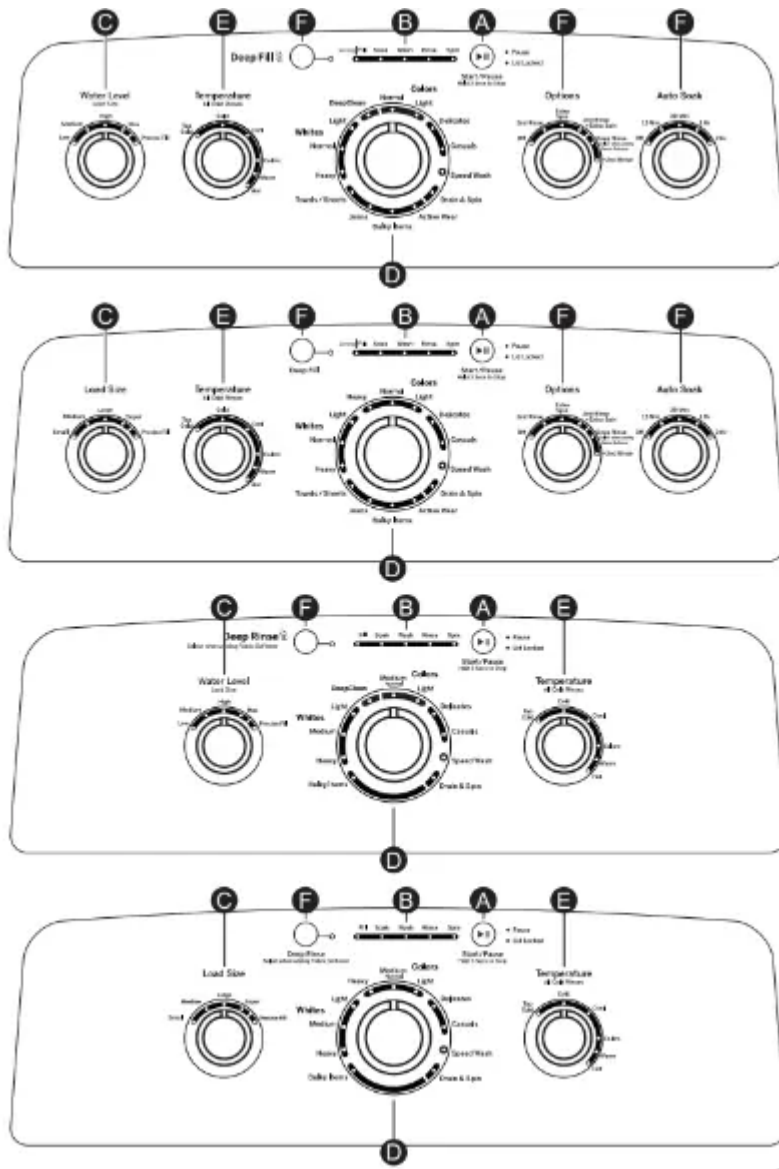

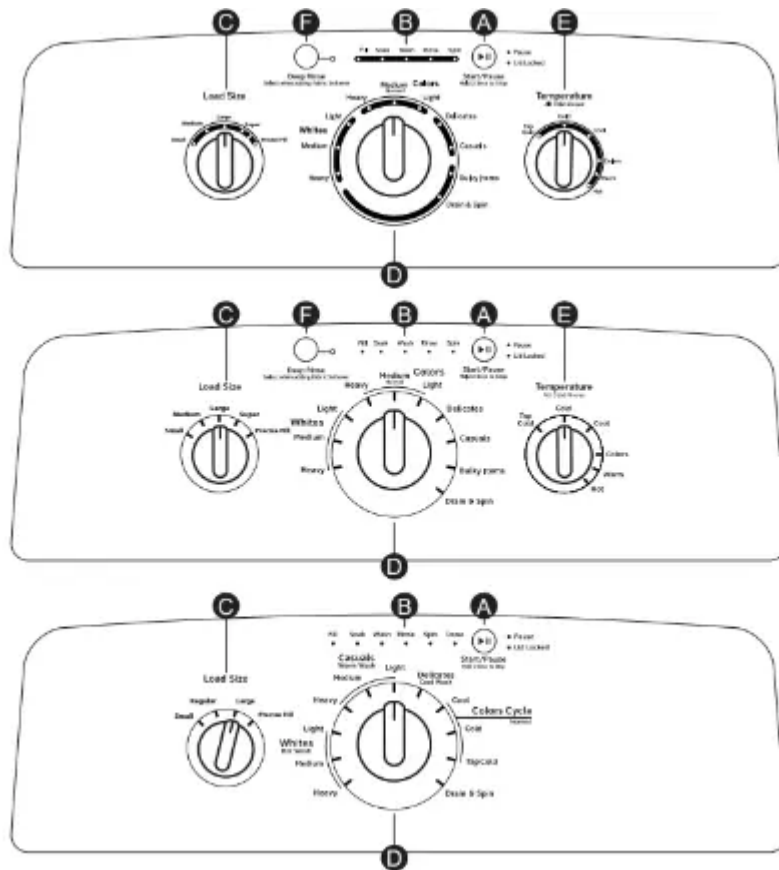

A. Start/Pause

Press **Start** to begin the cycle. **NOTE:** If the lid is closed, the lid will lock only during the load sensing portion of the cycle (when the Precise Fill selection is made or models which do not have a load size selection) and during spin portions of the cycle. Lid will unlock after load sensing and spin.

Pressing **Pause** will unlock the lid (if locked at that time), pause the cycle and the **Pause** indicator light will blink.

To continue the cycle, press **Start** again. If water remains in the machine, select the **Drain & Spin** cycle to drain basket and spin water out of the washer basket. **NOTE:** Machine will automatically cancel and drain when water is present and the lid is left open for 15 minutes or the unit is left in a paused state for 24 hours with the lid closed. Select cycle and press Start to begin new cycle.

B. Cycle Status Lights

Shows whether the washer is in the **Fill**, **Soak**, **Wash**, **Rinse** or **Spin** portion of the cycle.

If an out-of-balance condition is detected by the washer, the **Spin** light will blink during the remaining portion of the cycle and will stay illuminated for a short time after cycle completion. When this occurs, the washer is taking actions to correct the out-of-balance condition and complete the cycle normally. In some cases, the washer may not be able to balance the load and spin up to full speed. If you notice the load is more

wet than normal at the end of the cycle, redistribute the load evenly in the wash basket and run a Drain & Spin cycle.

C. Load Size (on some models)

Add detergent to the bottom of the basket and fabric softener to the dispenser (on some models) prior to loading clothes.

Loosely load items in the washer basket. Overloading may negatively impact wash performance. Adjust the load size accordingly.

Make the load selection:

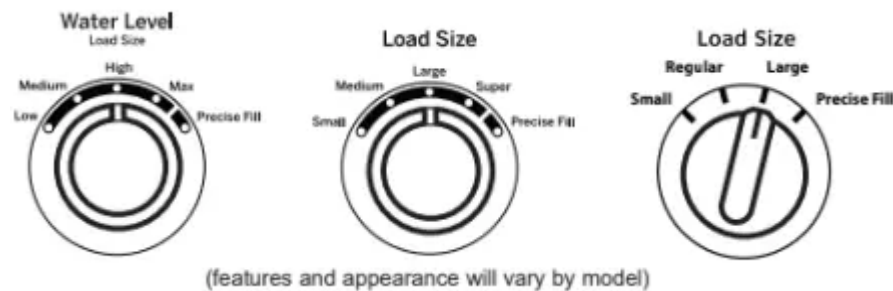

Precise Fill (on some models)

- For convenience, best performance and optimal efficiency, select Precise Fill for models so equipped. This selection automatically provides the correct amount of water suited to the size and type of load placed in the unit. Lid will be locked for the duration of the load size sensing process, which includes a brief spin period and a portion of the water fill.
- If you prefer to manually select the water level, select Low/Small through Max/Super (or Large on some models). While Precise Fill is best for most loads and general washing, you may want to manually select the load size for specialty items such as bulky, lightweight comforters or pillows, where you want to ensure a larger water level is applied. Manual load size selections should be made for wet items placed in the washer, such as soaked towels or garments.
- The washer will not fill with water when Precise Fill is selected if the lid is opened. When the lid is closed the machine is able to begin filling with water in order to sense the load size.

NOTE: This is a high-efficiency washing machine. This system requires less water while providing effective cleaning action. You may notice that the water level is lower than on your previous washer. This is normal.

D. Wash Cycles-Cycle Selector Knob - For models GTW500, GTW490, GTW485, GTW465, GTW460, GTW335, GTW330, GTW220 & HTW240 only.

The wash cycle controls the type of washing process. The cycle selector knob can be turned in either direction. Turning the knob after starting a cycle will stop the washer

and change the cycle/options to the new selection. Press Start to begin the new cycle selection.

The chart below will help you match the items to be washed with the best wash cycle settings. For optimal performance, select the cycle that most closely matches the items being washed.

Selections and options shown in bold are the recommended settings for that cycle.

Some cycles and options may not be available on some models.

| Items to Wash | Cycle | Wash Temp | Soil Level | Spin Selection (Duration) | Options Available | Cycle Details |
|---|-------------|--|---|--------------------------------|--|--|
| Cycle for normal, regular, or typical use for washing up to a full load of normally soiled cotton clothing. | Colors | Hot Warm Colors Cool Cold Tap Cold | Ex. Heavy Heavy Normal/ Medium Light Ex. Light | Max/Extra Normal | Stain PreTreat Guide Auto Soak Deep Rinse 2nd Rinse On GTW460 Model Only : Deep Fill | Cycle for normal, regular, or typical use for washing up to a full load of normally soiled cotton clothing. Choose the Heavy or Extra Heavy soil level selection and Warm or Hot water temperature selection as appropriate for your clothes load for a higher degree of cleaning. Incorporates multi-stage fills and wash periods to provide optimal fabric care. |
| Dark colored items, linens, and mixed loads. | Dark Colors | Hot Warm Colors Cool Cold Tap Cold | Ex. Heavy Heavy Normal/ Medium Light Ex. Light | Max/Extra Normal | Stain PreTreat Guide Deep Fill Auto Soak Deep Rinse 2nd Rinse | Lower wash temperatures, a shorter wash period, and a deep fill rinse (on some models) minimizes fading and spotting of dark colored fabrics. Incorporates multi-stage fills and wash periods to provide optimal fabric care. |
| Casual clothes, lightly soiled office wear. | Casuals | Hot Warm Colors Cool Cold Tap Cold | Ex. Heavy Heavy Normal/ Medium Light Ex. Light | Max/Extra Normal | Stain PreTreat Guide Deep Fill Auto Soak Deep Rinse 2nd Rinse | Wash period tailored to care for casual clothes and office wear items. Incorporates multi-stage fills and wash periods to provide optimal fabric care. |
| Lingerie and special care fabrics with light soil. | Delicates | Hot Warm Colors Cool Cold Tap Cold | Ex. Heavy Heavy Normal/ Medium Light Ex. Light | Max/Extra Normal | Stain PreTreat Guide Deep Fill Auto Soak Deep Rinse 2nd Rinse | Utilizes a unique "tri-pulse" extra gentle agitate profile and a low spin speed to provide special care to delicate fabrics. It is recommended to place small or ultra delicate items in mesh bags before washing. |
| Dark colored fabrics and mixed loads. | Cold Wash | Hot Warm Colors Cool Cold Tap Cold | Ex. Heavy Heavy Normal/ Medium Light Ex. Light | Max/Extra Normal | Deep Fill Auto Soak Deep Rinse 2nd Rinse | Cycle combines multiple extended wash agitation periods with soak periods to provide enhanced cleaning performance and energy efficiency with colder water temperatures. |
| Medium to lightly soiled athletic wear items of technical or synthetic fabrics. | Active Wear | Hot Warm Colors Cool Cold Tap Cold | Ex. Heavy Heavy Normal/ Medium Light Ex. Light | Max/Extra Normal | Stain PreTreat Guide Deep Fill Auto Soak Deep Rinse 2nd Rinse | Cycle designed for care of medium to lightly soiled active wear, athletic wear, and technical fabrics. Incorporates a multi stage wash period with soak to effectively treat body soils and odors. Use the Heavy Duty cycle for heavily soiled sports clothing constructed of sturdy fabric. |

D. Wash Cycles-Cycle Selector Knob - For model HTW200 only.

The wash cycle controls the type of washing process. The cycle selector knob can be turned in either direction. Turning the knob after starting a cycle will stop the washer and change the cycle options to the new selection. Press Start to begin the new cycle selection.



The chart below will help you match the items to be washed with the best wash cycle settings. For optimal performance, select the cycle that most closely matches the items being washed.

| Items to Wash | Cycle | Wash Temp | Soil Level | Spin Selection (Duration) | Cycle Details |
|---|--------------|--------------------------|--------------------------|---------------------------|---|
| Cycle for normal, regular, or typical use for washing up to a full load of normally soiled cotton clothing. | Colors | Cool Cold Tap Cold | Normal | Normal | Cycle for normal, regular, or typical use for washing up to a full load of normally soiled cotton clothing. Multiple wash temperature selections are available within this single cycle: Tap Cold: Coldest selection available, adds no hot water. Cold: Adds some hot water to aid dissolving detergents in colder climates. Cool: Adds more hot water to increase cleaning. The Normal cycle is identical in cycle steps, wash times, etc. for each wash temperature selection available. All rinses are cold. |
| Whites and household linens | Whites | Hot | Heavy Medium Light | Normal | Provides the hottest hot temperature available (based on your water heater setting) with longer wash periods to clean and brighten your whites. It is recommended that a Oxi or chlorine bleach product appropriate for items being washed be used with this cycle to maximize whitening performance. Note that three soil levels are available: Heavy, Regular, and Light. Rinse is cold. |
| Light colored items. More heavily soiled or items with body soils. | Casuals | Warm | Heavy Medium Light | Normal | Wash temperature and wash profile tailored for items that are more heavily soiled and/or contain body soils. Note that three soil levels are available: Heavy, Regular, and Light. Rinse is cold. |
| Lingerie and special care fabrics with light soil. Water-resistant, bedding and bulky items, such as large coats, mattress pads, and bath mats. | Delicates | Cool | Light | Normal | Utilizes a unique "tri-pulse" extra gentle agitate profile and a low spin speed to provide special care to delicate fabrics. It is recommended to place small or ultra delicate items in mesh bags before washing. |
| Wet load of items. | Drain & Spin | | | Normal | Utilizes a high speed spin to extract water from wet items. |

NOTE: Water temperature selections are embedded within the wash cycles. For the Colors Cycle Normal, there are multiple temperature selections available. For other cycles, such as Whites, there is only one temperature available but there are multiple soil levels embedded. Select the cycle, temperature and soil level that best matches items being washed.

E. Settings

Select settings for agitation (Soil) and water temperature (Temp).

NOTE: Longer Spin times typically reduce dryer time/energy usage (i.e. reduces total energy when using both a washer and a dryer).

F. Cycle Options (on some models)

Stain PreTreat

The **Stain PreTreat** feature allows you to indicate what stains are on the garments in your load. An initial water fill is performed at a temperature tailored to the stain type selected and to an amount which enables a concentrated

cleaning step. A stain scrubbing period, followed by an active soak, is conducted to effectively treat the stain. Then additional water is added to the selected temperature and the wash phase is conducted for the cycle selected. For washing normally soiled cotton clothing the Stain PreTreat option should be in the **Off** position. This feature can be applied to most wash cycles as described in the cycle guide.

To use Stain PreTreat:

1. Select the desired wash cycle.
2. Select the stain to be treated under the **Stain PreTreat** options.

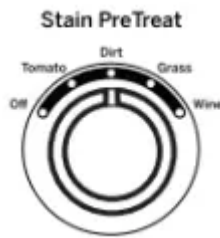

Stain PreTreat Guide

| Category | Recommended Temperatures Treatment/Wash | Stain | For best results, before placing in washer: |
|----------|---|--|--|
| Tomato | Cool/Warm | Sauce Catsup Salsa | Pretreat with liquid detergent or stain remover product; rinse with cool water. |
| Dirt | Cool/Warm | Dirt Clay Mud | Allow dirt to dry; remove loose dirt using a brush. Rinse with cool water. |
| Grass | Cold/Warm | Grass Lipstick Chocolate Gravy Mayonnaise BBQ Sauce | Pretreat with liquid detergent or stain remover product. Brush lightly; rinse with cold water. |
| Wine | Cool/Warm | Wine Soda Kool-Aid Tea Coffee Juice Beer | Pretreat with mixture of Oxi product and cool water. Add Oxi product along with detergent in the washer. |

- Recommended temperatures are optimal for stain removal performance; adjust temperature selection to suit load being washed.
- Ensure stain is completely removed after wash cycle and before placing in dryer; very tough stains may require a second treatment.

Deep Fill

Select the **Deep Fill** feature for loads where extra water is needed. The **Deep Fill** feature is recommended for special case loads only, not for typical use.

Press the **Deep Fill** button once before starting the cycle to add an incremental amount of water to the wash load. Holding the **Deep Fill** button for 3 seconds



will provide the deepest fill level possible; this will increase cycle time due to the additional time it takes to fill the washer.

To cancel the option if desired, press the **Deep Fill** button again.

NOTE: The Deep Fill button can also be pressed after the washer has completed filling and is in the wash phase if additional water is desired. To stop the extra fill, press the Deep Fill button again and the water will stop.

Auto Soak

This option begins with a brief agitation, soaks for a specified period of time, then moves through the rest of the cycle automatically. **2nd Rinse**

When you use extra detergent or bleach to clean heavily soiled clothes, use the 2nd Rinse option to better remove additional residues.

Extra Spin

Select to provide additional spin time, increasing energy efficiency through reducing drying times.

2nd Rinse + Extra Spin

Provides both a second rinse and an extra spin.

Deep Rinse

Set this option to provide a deep rinse or when using fabric softener. This option may change other settings (e.g. Spin may go to a higher setting) to maximize performance.

NOTE: For models GTW490 and GTW500 only. If liquid fabric softener is desired, wait until the Rinse cycle status light is lit and the final rinse fill is complete before adding the recommended amount of liquid fabric softener directly to the rinse bath. When adding liquid fabric softener, pour into deeper areas of rinse water while avoiding direct contact with fabric.

Consumer Help Indicator

Your washer is equipped with Consumer Help Indicator (CHI). CHI is our way to communicate a simple remedy for some situations that you can perform without the need to call for service. The chart below describes the helpful lights you may notice flashing on the display.

Spin light blinking

If an out-of-balance condition is detected by the washer, the Spin light will blink during the remaining portion of the cycle and will stay illuminated for a short time after cycle completion. When this occurs, the washer is taking actions to correct the out-of-balance condition and complete the cycle normally. In some cases,

the washer may not be able to balance the load and spin up to full speed. If you notice the load is more wet than normal at the end of the cycle, redistribute the load evenly in the wash basket and run a Drain & Spin cycle.

Fill light (Water not entering washer)

Check your house water supply. Did you forget to turn on one or both supply valves after installation or coming back from vacation? As soon as the light starts to flash, the washer will initiate a 4 minute lock- out period. The washer controls won't respond/change during this time. After the 4 minutes, you can begin your cycle again. If you try to bypass the lock-out period by unplugging the washer, the 4 minute timer will start over again.

Lid Locked light

Lid Locked light will flash if 3 cycles have been started without opening the lid. The washer will not start another cycle until the lid is opened. Try opening, then closing the lid and starting a new cycle. If the problem persists, call GE Appliances at 800.GE.CARES (800.432.2737) for service.

Automatic Load Sensing

This determines the correct agitate profile, agitate duration and amount of water suited to the size and type of load placed in the washer. The washer will not start the wash cycle or fill with water if the lid is open. When the lid is closed the machine is able to begin filling with water in order to sense the load size.

NOTE: Automatic Load Sensing initiates a spin at the beginning of the cycle and will take as much as 3 minutes to complete (significantly shorter for smaller loads); this is normal operation.

NOTE: This is a high efficiency washing machine. This system requires less water while providing effective cleaning action. You may notice that the water level is lower than on your previous washer. This is normal.

Liquid Fabric Softener Dispenser (on some models)

The agitator cap fits into the top of the agitator. If it accidentally comes off, simply put it back on.

The fabric softener dispenser automatically releases liquid fabric softener at the proper time during the cycle.

Do not stop the washer or raise the lid during the first spin. This will cause the dispenser to empty too soon.

To use, follow these steps:

1. Make sure dispenser is securely attached to agitator.

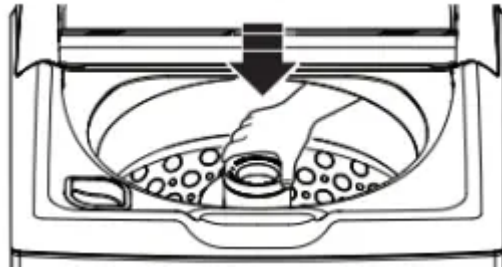

ONLY this portion of the dispenser is visible once installed into agitator

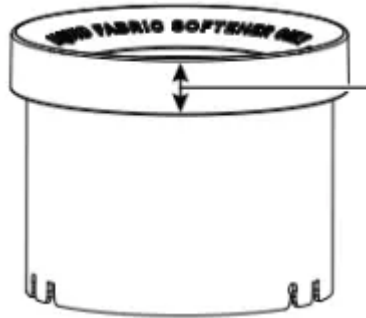

2. Use only liquid diluted fabric softener. Pour into dispenser, using amount recommended on package.

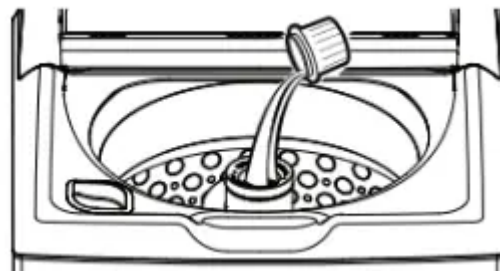

Never pour fabric softener directly on clothes. It may stain them.

3. Add water to dispenser until it reaches the maximum fill line.

Do not pour anything into the agitator if the agitator cap or dispenser is removed.



4. Select Deep Rinse option.



NOTE: Fabric softener may not dispense properly if the **Deep Rinse** option is not selected.

Liquid Bleach

Liquid chlorine bleach should be added through the bleach dispenser in the front left corner. Follow bleach manufacturer's recommendations for the correct amount of liquid chlorine bleach based on load size, taking care to not apply or spill it directly on clothing.



NOTE: Do not use liquid chlorine bleach and laundry pretreatments such as an Oxi product in the same wash load.

Pretreatment

Place laundry pretreatments, such as an Oxi product, directly in the bottom of the wash basket before loading clothes.

NOTE: Do not use liquid chlorine bleach and laundry pretreatments such as an Oxi product in the same wash load.

Loading

Always follow fabric manufacturer's care label when laundering.

Proper Use of Detergent

Using too little or too much detergent is a common cause of laundry problems.

Use less detergent if you have soft water, a smaller load or a lightly soiled load.

For spots, apply pre-treatment to items as recommended on the product label.

Application should be made in the basket to prevent overspray which may cause the coloring on the lid or graphics to fade.

Place detergent packets in the bottom of the wash basket before adding clothes.

GE Appliances recommends the use of High Efficiency detergents such as  in your energy efficient washer. HE detergents are formulated to work with low water wash and rinse systems. HE detergents reduce the oversudsing problems commonly associated with regular detergents.

When using high efficiency or concentrated detergents, consult the product label to determine amount required for optimum performance. Excessive detergent will negatively impact wash performance.

Sorting Wash Loads

Sort by color (whites, lights, colors), soil level, fabric type (sturdy cottons, easy care, delicates) and whether the fabric produces lint (terry cloth, chenille) or collects lint (velveteen, corduroy). Wash lint producers such as cotton towels and socks separate from lint collectors including synthetic garments and dress pants.

⚠ WARNING



Fire Hazard

DO NOT wash fabrics soiled with flammable liquids or cleaning solvents.

No washer can completely remove oil.

DO NOT wash or dry anything that has been soaked in or spotted with any type of oil (including cooking oils).

DO NOT reach into the washer until all moving parts have stopped.

Doing so can result in death, explosion, fire or amputation. Loading the Washer

Loading the Washer

Load dry items loosely in the washer basket. For best results, load items evenly and loosely around the outside of the basket, filling in towards the center on larger loads. To add items after washer has started, press Start/Pause if the lid is locked; wait until the Lid Lock indicator on the display is no longer illuminated before attempting to open the lid. Lift the lid and submerge additional items around the outside of the basket. Close the lid and press Start to resume. Adjust load size selection and/or use Deep Fill option if necessary.

- On Infusor models, do not place large items such as sheets, blankets and towels across the Infusor. Load them around the outside of the basket.
- Do not put lawn or sofa cushions into the washer as they are too big to move. Remove outer covers and ONLY wash them.

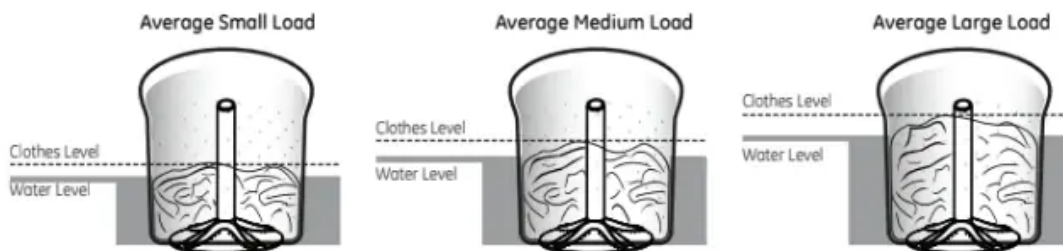

Care and cleaning

⚠ WARNING



Electrical Shock Hazard

Certain internal parts are intentionally not grounded and may present a risk of electric shock only during servicing.

Service personnel – DO NOT contact the following parts while the appliance is energized: Drive Motor, Lid Lock, Water Valves, Drain Pump and Recirculation Pump.

Exterior of the Washer

Immediately wipe off any spills with a damp cloth.

Interior of the Washer

Leave the lid open after washing to allow moisture to evaporate. If you want to clean the basket, use a clean soft cloth dampened with liquid detergent; then rinse. (Do not use harsh or gritty cleaners.)

Cleaning the Fabric Softener Dispenser (on some models)

1. Remove the dispenser from the top of the agitator.
2. Separate the dispenser cup from the cover by grasping the top and pushing down on the inside of the cup with your fingers. Dispenser cup will pop free from the cover.
3. To clean the dispenser, soak both the dispenser cup and the dispenser cover in the following solution:
 - 1 US gallon (3.8 liters) warm water
 - 1/4 cup (60 ml) heavy-duty liquid detergent
 - 1 cup (240 ml) bleach

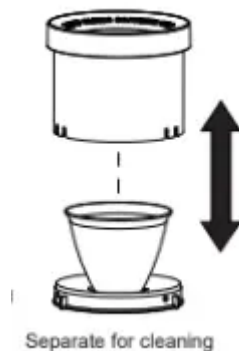

4. If necessary, loosen buildup with a clean, soft cloth after soaking. Do not use a stiff brush; you may roughen the surface of the dispenser.
5. Rinse and reassemble dispenser. Place dispenser back on the agitator.

Water Supply Hoses

Hoses connecting washer to faucet should be replaced every 5 years.

Moving and Storage

Ask the service technician to remove water from drain pump and hoses. Do not store the washer where it will be exposed to the weather.

Long Vacations

Be sure water supply is shut off at faucets. Drain all water from hoses and water filter pump area if weather will be below freezing.

Installation Instructions

PARTS SUPPLIED

□ Drain Hose



□ Owner's Reference Guide



□ Cable Tie



□ Drain Hose Clip



□ Clamp



TOOLS REQUIRED FOR WASHER INSTALLATION

□ Pliers



□ Level



PARTS REQUIRED (Sold separately)

□ Water Hoses (2)



□ Rubber Washers (2)
and Strainer Screens (2)



□ Drain Hose Extension (For discharge heights from 60" - 96")

LOCATION OF YOUR WASHER DO NOT Install the Washer:

1. In an area exposed to dripping water or outside weather conditions. The ambient temperature should never be below 60°F (15.6°C) for proper washer operation.
2. In an area where it will come in contact with curtains or drapes.
3. On carpet. The floor MUST be a hard surface with a maximum slope of 1/2" per foot (1.27 cm pre 30 cm). . To make sure the washer does not vibrate or move, you may have to reinforce the floor.

IMPORTANT: Minimum Installation Clearances - Alcove or Closet

- If your washer is approved for installation in an alcove or closet, there will be a label on the back of the machine describing requirements.
- Minimum clearance between washer and adjacent walls or other surfaces: 0" either side, 2" front, 3" rear.
- Vertical space from floor to overhead shelving, cabinets, ceiling, etc. = 60".
- Closet doors must be louvered or otherwise ventilated and have at least 60 square inches of open area. If the closet contains both a washer and a dryer, doors must contain a minimum of 120 square inches of open area.

NOTE: The clearances stated on this label are minimums. Consideration must be given to providing adequate clearances for installing and servicing.

WATER SUPPLY REQUIREMENTS

WATER SUPPLY LINES - Purge Hot and Cold water supply lines for 30 seconds prior to installation of hoses and washing machine. Ensure inlet hose screens are also clean and free of debris.

WATER PRESSURE - Must be 20 psi minimum to 120 psi maximum.

WATER TEMPERATURE - Household water heater should be set to deliver water at 120° to 150°F (50° to 66°C) **TO THE WASHER** when hot wash is selected.

SHUTOFF VALVES - Both hot and cold shutoff valves (faucets) should be supplied.

DRAIN - Water should be drained into standpipe. Discharge height **MUST NOT BE LESS THAN 30 INCHES**, and no more than 8 feet above the base of the washer. Standpipe must be 1-1/2 inches minimum inside diameter and must be open to atmosphere.

1. UNPACKING THE WASHER

After the machine is in the home, remove outside packing material/carton from washer. Remove bag (containing clamp, cable tie and drain hose clip), drain hose and Owner's Reference Guide from tub.

NOTE: Leave foam shipping material inside tub opening to hold tub in place during the rest of installation.

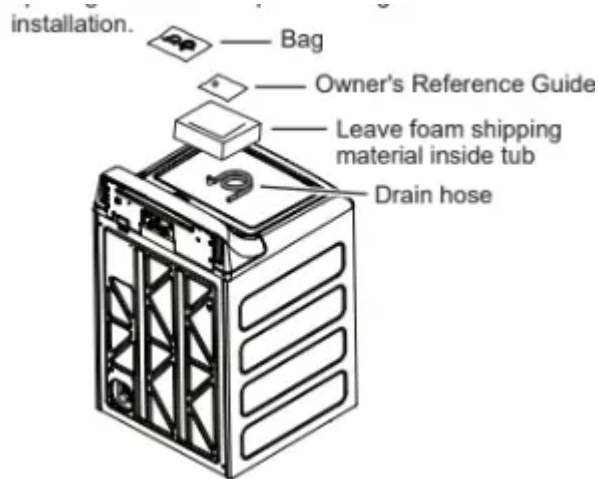

2. REMOVE THE BASE

Remove base from unit by placing foot on side of base and tipping unit back on corner post. Remove base and bring the washer back upright.

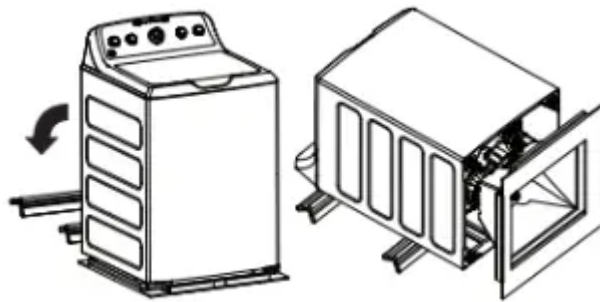

⚠ WARNING Electrical Shock Hazard

Certain internal parts are intentionally not grounded and may present a risk of electric shock only during servicing.

Service personnel – DO NOT contact the following parts while the appliance is energized: Drive Motor, Lid Lock, Water Valves, Drain Pump and Recirculation

3. CONNECT DRAIN HOSE TO WASHER

Remove the cap from the drain port, if present, before installing the drain hose.

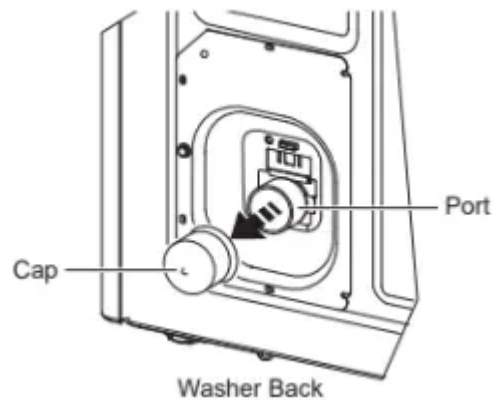

Connect drain hose to drain port on back of washer. Open clamp with pliers and slide onto hose end. Holding clamp open, push hose end onto drain port until fully seated.

Release clamp between locating ribs on hose end. Outlet of hose end should be oriented vertically.

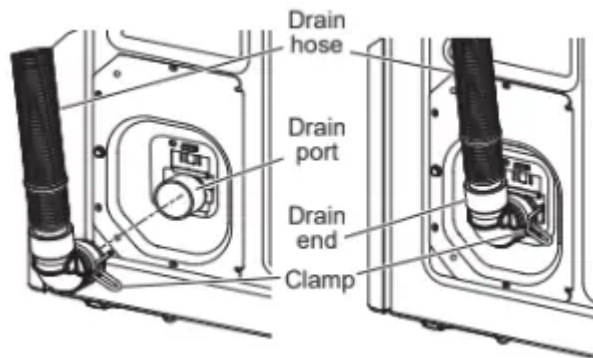

4. CONNECT WATER HOSES TO WASHER

Unplug electrical cord before installing water hoses. If not installed, install rubber washer in one end of hot water hose. Thread hot water hose onto connection labeled H at top rear of washer. Hand tighten and use pliers to tighten hoses between 1/8 and 1/4 turn beyond hand-tight.

If not installed, install rubber washer in one end of cold water hose C. Thread cold water hose onto connection labeled C at top rear of washer. Hand tighten and use pliers to tighten hoses between 1/8 and 1/4 turn beyond hand-tight.

Move washer as close to final location as possible leaving room for you to make water, drain, and electrical connections to your home.

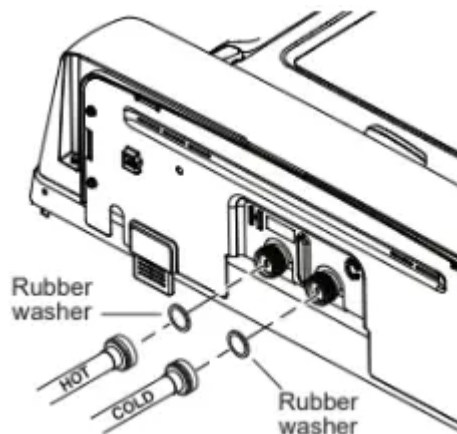

5. CONNECT WATER HOSES TO OUTLET VALVES

Determine which is HOT water line before attaching water hoses to faucets. Traditionally, HOT faucet is on left.

(If screen washers are not installed) With protruding part of screen toward you, install strainer screen/rubber washer into each of the free ends of two water hoses.

Connect hot water hose to hot water outlet valve of your home. Hand tighten and use pliers to tighten hoses between 1/4 and 1/2 turn beyond hand-tight. Open hot water valve.

Connect cold water hose to cold water outlet valve of your home.

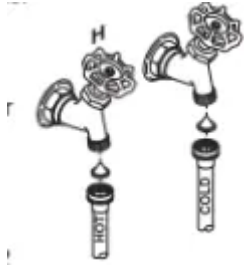

Hand tighten and use pliers to tighten hoses between 1/4 and 1/2 turn beyond hand-tight. Open cold water valve.

Check for leaks and drips at the hose couplings. Tighten as necessary.

6. CONNECT TO DRAIN

Install drain hose clip on rear panel of washer. Route drain hose through clip and insert free end into drain opening of your home.

NOTE: If longer drain hose is required, order drain hose extension kit, GE Appliances part number WH49X301. Connect additional drain hose (contained in kit) to original hose with hose clamp contained in kit).

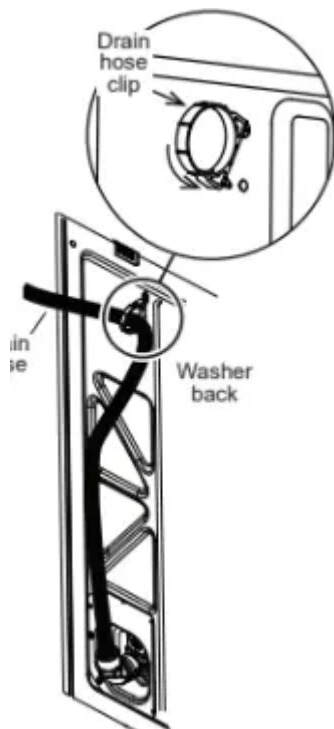

If water valves and drain are built into wall, fasten drain hose to one of the water hoses with cable tie provided.

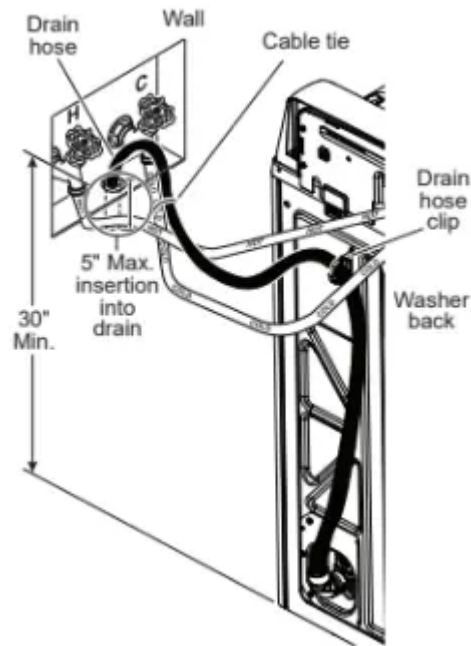

NOTE: Placing the drain hose too far down the drain pipe can cause a siphoning action. No more than 5" of hose should be in the drain pipe. There must be an air gap around the drain hose. A snug fit can also cause a siphoning action.

If your drain is a standpipe, fasten drain hose to standpipe with cable tie provided.

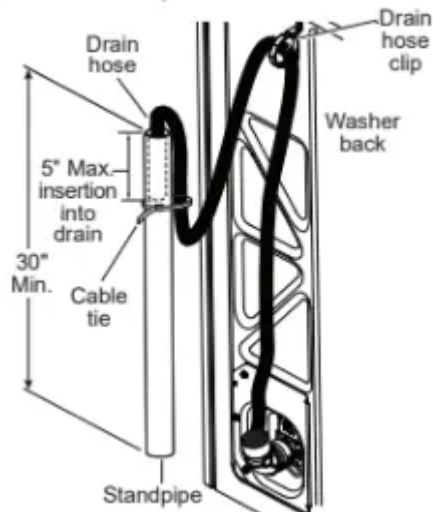

NOTE: Placing the drain hose too far down the drain pipe can cause a siphoning action. No more than 5" of hose should be in the drain pipe. There must be an air gap around the drain hose. A snug fit can also cause a siphoning action.

If drain discharge height does not meet 30" minimum height requirement, end of drain hose must be secured in drain opening of home by installer and have an air gap around hose to prevent siphoning.

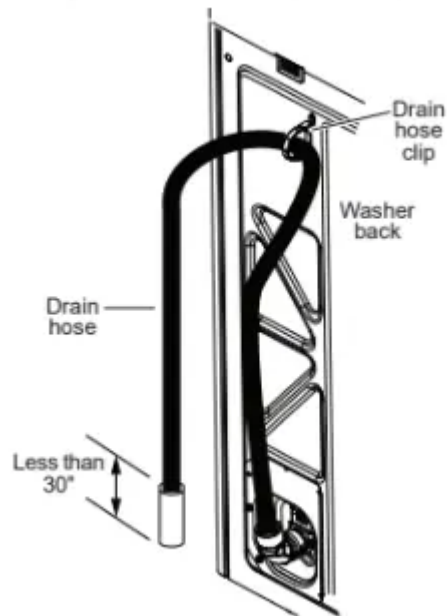

NOTE: Placing the drain hose too far down the drain pipe can cause a siphoning action. No more than 5" of hose should be in the drain pipe. There must be an air gap around the drain hose. A snug fit can also cause a siphoning action.

ELECTRICAL REQUIREMENTS

⚠ WARNING **Electrical Shock Hazard**

Plug into a grounded 3-prong outlet.

DO NOT remove ground prong.

DO NOT use an adapter.

DO NOT use an extension cord.

Failure to follow these instructions can result in death, fire or electrical shock.

CIRCUIT – Individual, properly polarized and grounded or 20 amp circuit breaker or time-delay fuse.

POWER SUPPLY – 2 wire plus ground, 120 Volt, single phase, 60 Hz, alternating current.

Outlet Receptacle – Properly grounded 3-prong receptacle to be located so the power cord is accessible when the washer is in an installed position. If a 2-prong receptacle is present, it is the owner's responsibility to have a licensed electrician replace it with a properly grounded 3-prong grounding type receptacle.

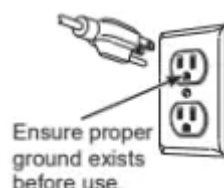

Washer must be electrically grounded in accordance with local codes and ordinances, or in the absence of local codes, with latest edition of the NATIONAL ELECTRICAL CODE, ANSI/

NFPA NO. 70 or CANADIAN ELECTRICAL CODE, CSA C22.1. Check with a licensed electrician if you are not sure that the washer is properly grounded.

7. CONNECT POWER AND INSTALL

Make sure large dial control (on some models) on washer is pushed in to the OFF position.

Insert plug of electrical cord into a 115V, 15- or 20-amp wall receptacle. Move washer into final position. Place level on flat top side edges of washer. Adjust all four leveling legs until washer is level left-to-right and front-to-back. Remove level.

Open tub lid. Remove and discard tub shipping material (see Step 1).

Remove plastic protector sheet from control panel face.

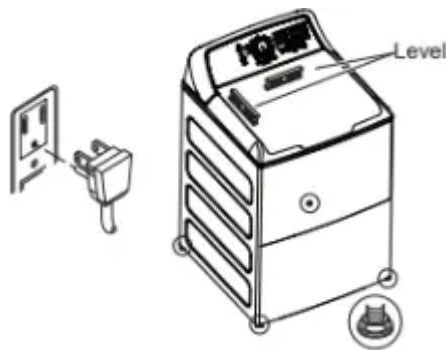

GROUNDING INSTRUCTIONS

This appliance must be grounded. In the event of malfunction or breakdown, grounding will reduce the risk of electric shock by providing a path of least resistance for electric current. This appliance is equipped with a cord having an equipment- grounding conductor and a grounding plug. The plug must be plugged into an appropriate outlet that is properly installed and grounded in accordance with all local codes and ordinances.

▲WARNING Improper connection of the equipment- grounding conductor can result in a risk of electrical shock. Check with a qualified electrician, or service representative or personnel, if you are in doubt as to whether the appliance is properly grounded.

DO NOT modify the plug on the power supply cord. If it will not fit the outlet, have a proper outlet installed by a qualified electrician.

If required by local codes, an external 18 gauge or larger copper ground wire (not provided) may be added. Attach to washer cabinet with a #10-16 x 1/2" sheet metal screw (available at any hardware store) to rear of washer as illustrated.

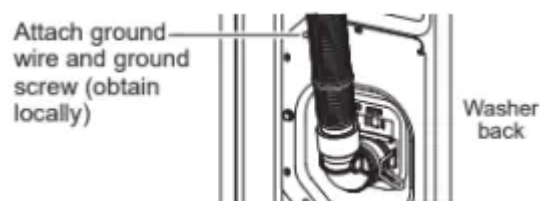

Mobile Home Installation:

Installation must conform to Standard for Mobile Homes, ANSI A119.1 and National Mobile Home Construction and Safety Standards Act of 1974 (PL93-383).

FINAL CHECKLIST

Before starting the washer, check to make sure:

- Main power is turned on.
- The washer is plugged in.
- The water faucets are turned on.
- The unit is level and all four leveling legs are firmly on the floor.
- The shipping foam and cardboard are removed.
- The drain hose is properly tied up.
- There are no leaks at the faucet, drain line or washer.
- Remove the cap from the drain port, if present, before installing the drain hose.

Run the washer through a complete cycle.

- Check for water leaks and proper operation.
- Place these instructions in a location near the washer for future reference.

TROUBLESHOOTING

Short spray and delay after pushing the Start button

- Lid was opened and closed between cycle selection and start
 - This is normal. See START-UP SEQUENCE in the Safety Instructions section.

Water level seems low

- This is normal
 - Water may not cover the top level of the clothes. This is normal for this high efficiency washer.

Low water flow

- Water valve screens are stopped up
 - Turn off the water source and remove the water connection hoses from the upper back of the washer and the water faucets. Clean both the hose screens (if so equipped) and the screens in the machine using a brush or a toothpick. Reconnect the hoses and turn the water back on. Check to ensure there are no leaks at the connections.

Water siphoning out of washer

- Drain standpipe is too low or hose too far into standpipe
 - The drain hose must exceed 30" height at some point between the washer back and the drain pipe. Use anti-siphon clip. See the Installation Instructions.

Too many suds

- Soft water
 - Try less detergent.
- Too much detergent
 - Measure your detergent carefully. Use less soap if you have soft water, a smaller load or a lightly soiled load.
- Type of detergent
 - Switch to High Efficiency detergent such as 

Water leaks

- Type of detergent
 - Switch to High Efficiency detergent such as 
- Using too much detergent in washer
 - Use less detergent. Use less soap if you have soft water, a smaller load or a lightly soiled load.
- Fill hoses or drain hose is improperly connected
 - Make sure hose connections are tight at faucets and rubber washers are installed. Make sure end of drain hose is correctly inserted in and secured to drain facility.
- Household drain clogged
 - Check household plumbing. You may need to call a plumber.
- Drain hose rubs on wall
 - Make sure drain hose does not make contact with the wall. May cause excessive wear on the hose.
- Constant water pressure to fill hoses at water source
 - Tighten hoses at the faucets. Check condition of the fill hoses; they should be replaced every 5 years.

Water temperature seems incorrect

- Cooler water temperatures provide improved energy efficiency
 - New laundry detergents have been formulated to work with cooler water temperatures without affecting wash performance
- Water supply is turned off or improperly connected
 - Turn both hot and cold faucets fully on and make sure hoses are connected to correct faucets. **NOTE:** Water valves are marked "H" and "C".
- Water valve screens are stopped up
 - Turn off the water source and remove the water connection hoses from the upper back of the washer and the water faucets. Clean both the hose screens (if so equipped) and the screens in the machine using a brush or a toothpick. Reconnect the hoses and turn the water back on. Check to ensure there are no leaks at the connections.
- Cool/Cold Water when selecting Hot
 - This is normal. The washer senses water temperature (on some models) and optimizes for best results. Cold water is added periodically when hot is selected.
- House water heater is not set properly
 - Make sure house water heater is delivering water at F–140°F (48°C–60°C).

Water pumped out before cycle is complete

- Water was left in unit for hours with lid closed or minutes with lid open
 - Previous cycle has been cancelled. Close lid, select new cycle, and start machine.

Water won't drain

- Drain hose is kinked or improperly connected
 - Straighten drain hose and make sure washer is not sitting on it. Top of drain outlet should be less than 8 ft (2.44 m) above floor.

Washer spins and pauses at the beginning of cycles

- This is normal
 - The washer is sensing the load.

Washer pauses during wash cycle

- The Soak Option was chosen
 - This is normal. The washer alternates between agitate and soak during these cycles to get your clothes cleaner with less wear.
- This is normal
 - Many cycles incorporate a series of soaks within the agitation period to get your clothes clean with less wear.

Laundry additives dispensing too soon (Dispensers on some models)

- Overfilling of dispensers
 - Do not overfill or add water to dispenser. Select Deep Rinse option when using fabric softener.

Washer pauses during spin cycle

- This is normal
 - The washer may pause during the spin cycle to remove soapy water more efficiently.

Washer won't operate

- Washer is unplugged
 - Make sure cord is plugged securely into a working outlet.
- Water supply is turned off
 - Turn both hot and cold faucets fully on.
- Lid is open—safety feature prevents agitation and spinning when lid is up
 - Close lid and press Start.
- Circuit breaker/fuse is tripped/blown
 - Check house circuit breakers/fuses. Replace fuses or reset breaker. Washer should have a separate outlet
- Electronics need to be reset
 - Unplug washer, wait 2 minutes, plug back in and press Start.
- Start was not pressed
 - Press Start.

Detergent packets not dissolving

- Laundry detergent packet placed in dispenser
 - Laundry detergent packets should not be used in the dispensers. They should only be added directly to the wash basket following the manufacturer's directions.

Unexplained time and/or settings changes

- Changing options (on some models)
 - This is normal. Several options will change other options to maximize washer performance.

Basket seems loose

- Basket moves or rotates freely
 - Washer basket does not have a traditional brake. Washer basket will move freely. This is normal.

Agitator seems loose (on some models)

- Agitator top moves/has side-to-side movement
 - Agitator top is designed to be flexible to allow for care of large bulky items such as comforters; this is normal.

Colored spots

- Incorrect use of fabric softener
 - Check fabric softener package for instructions and follow directions for using dispenser. Make sure you have selected the Deep Rinse option. (on some models) .Pretreat stain and rewash using Speed Wash cycle before drying. (on some models)
- Dye transfer
 - Sort whites or lightly colored items from dark colors.

Grayed or yellowed clothes

- Detergent amount
 - Be sure to follow detergent manufacturer's directions.
- Hard water
 - Use a water conditioner or install a water softener.
- Water is not hot enough
 - Make sure water heater is delivering water at 120°F–140°F C–60°C).

- Washer is overloaded
 - Loosely load clothes no higher than the top row of holes in the washer basket. For best results, load items around the outside of the basket.
- Dye transfer
 - Sort clothes by color. If fabric label states wash separately, unstable dyes may be indicated.

Lint or residue on clothes

- Clothes are air or line dried
 - If you do not dry your clothes with a clothes dryer, your clothes may retain more lint.
- Incorrect sorting
 - Separate lint producers from lint collectors.
- Washing too long
 - Wash small loads for a shorter time using Light Soil setting.
- Detergent not dissolving
 - Rewash; next time: Try a liquid detergent .Use warmer water temperature.
- Overloading
 - Loosely load clothes in the washer basket. For best results, load items around the outside of the basket.
- Incorrect use of fabric softener
 - Check fabric softener package for instructions and follow directions for using dispenser. Make sure you have selected the Deep Rinse option. (on some models)

Clothes too wet

- Incorrect cycle selected
 - Make sure the cycle selected matches the load you are washing. Some fabrics will feel wetter when rinsed with cold water.
- Wash load out of balance
 - Redistribute load in washer and run through Drain & Spin cycle.

Blinking Spin light or Spin light on at end of cycle

- Out of balance condition has been detected
 - Allow cycle to continue and finish. If load is wet at the end of the cycle, even out load and run a Drain & Spin cycle.

Pilling

- Result of normal wear on poly-cotton blends and fuzzy fabrics
 - While this is not caused by the washer, you can slow the pilling process by washing garments inside out.

Snags, holes, tears, rips or excessive wear

- Pins, snaps, hooks, sharp buttons, belt buckles, zippers and sharp objects left in pockets
 - Fasten snaps, hooks, buttons and zippers. Remove loose items like pins, objects in pockets and sharp buttons. Turn knits (which snag easily) inside out.
- Undiluted chlorine bleach
 - Check bleach package instructions for proper amount. Never add undiluted bleach to wash or allow clothes to come in contact with undiluted bleach
- Chemicals like hair bleach or dye, permanent wave solution
 - Rinse items that may have chemicals on them before washing. Use Speed Wash cycle with Extra Rinse option. (on some models)

Wrinkling

- Incorrect wash and dry cycles
 - Match Cycle selection to the type of fabric you are washing especially for easy care loads).
- Improper sortin
 - Avoid mixing heavy items (like jeans) with light items (like blouses). Try a fabric softener.
- Overloading
 - Loosely load clothes in the washer basket.
- Repeated washing in water that is too hot
 - Wash in warm or cold water.

"Clicking"

- Shifter mechanism is engaging or disengaging
 - The drive system will engage at the start of agitate and disengage when agitate is complete. This occurs multiple times during the wash.

Back and forth "swoosh"

- Electric motor reversing direction
 - This sound is the motor rotating back and forth to clean your laundry.

"Clicking" behind Control during fill

- Automatic Temperature Control Valve
 - Two valves mix cold and hot water. The "clicking" is when either valve turns on or off to raise or lower the fill water temperature.

Water flow changes during fill

- Automatic Temperature Control Valve
 - Two valves mix cold and hot water. The "clicking" is when either valve turns on or off to raise or lower the fill water temperature.

Motor sounds during spin

- Motor ramping up/down during spin cycle
 - The motor will speed up incrementally during the spin cycle. When spin is complete, it will coast until it stops.

"Humming"

- Water drain pump
 - The drain pump will make a humming sound when pumping out water after agitation stops and continue until spin is complete.
- Drive motor
 - The drive motor will make a "humming" sound during the wash and spin phases of the cycle.

"Gurgling"

- Water drain pump
 - When the pump starts drawing in air, It starts to gurgle. The washer should then begin spinning and the sound will continue until it is done spinning.

Water “swishing”

- Washing process
 - Water swishing while the unit is agitating is normal, especially with smaller loads.

Washer rocking/ moving

- Washer leveling legs uneven
 - To level the washer, adjust the leveling legs by rotating the individual leg in the proper direction for up or down.

“Squeaking” sound

- Washer not level and rubbing on cabinet
 - To level the washer, adjust the leveling legs by rotating the individual leg in the proper direction for up or down.

LIMITED WARRANTY

All warranty service is provided by our Factory Service Centers, or an authorized Customer Care® technician. To schedule service online, visit us at GEAppliances.com/service, or call GE Appliances at 800.GE.CARES (800.432.2737). Please have your serial number and your model number available when calling for service.

Servicing your appliance may require the use of the onboard data port for diagnostics. This gives a GE Appliances factory service technician the ability to quickly diagnose any issues with your appliance and helps GE Appliances improve its products by providing GE Appliances with information on your appliance. If you do not want your appliance data to be sent to GE Appliances, please advise your technician not to submit the data to GE Appliances at the time of service.

| For the period of: | We will replace: |
|--|---|
| One year From the date of the original purchase | Any part of the washer which fails due to a defect in materials or workmanship. During this limited one-year warranty , we will also provide, free of charge , all labor and related service to replace the defective part. |

What is not covered:

- Service trips to your home to teach you how to use the product.
- Improper installation, delivery or maintenance.
- Failure of the product if it is abused, misused, or used for other than the intended purpose or used commercially.
- Replacement of house fuses or resetting of circuit breakers.
- Products which are not defective or broken, or which are working as described in the Owner’s Manual.



- Damage to the product caused by accident, fire, floods or acts of God.
- Incidental or consequential damage caused by possible defects with this appliance.
- Defects or damage due to operation in freezing temperatures.
- Damage caused after delivery.
- Product not accessible to provide required service.

EXCLUSION OF IMPLIED WARRANTIES

Your sole and exclusive remedy is product repair as provided in this Limited Warranty. Any implied warranties, including the implied warranties of merchantability or fitness for a particular purpose, are limited to one year or the shortest period allowed by law.

In the United States:

This limited warranty is extended to the original purchaser and any succeeding owner for products purchased for home use within the USA. If the product is located in an area where service by a GE Appliances Authorized Servicer is not available, you may be responsible for a trip charge or you may be required to bring the product to an Authorized GE Appliances Service location for service. In Alaska, the limited warranty excludes the cost of shipping or service calls to your home.

Some states do not allow the exclusion or limitation of incidental or consequential damages. This limited warranty gives you specific legal rights, and you may also have other rights which vary from state to state. To know what your legal rights are, consult your local or state consumer affairs office or your state's Attorney General.

In Canada:

This limited warranty is extended to the original purchaser and any succeeding owner for products purchased in Canada for home use within Canada. If the product is located in an area where service by a GE Appliances Authorized Servicer is not available, you may be responsible for a trip charge or you may be required to bring the product to an Authorized GE Appliances Service location.

Some provinces do not allow the exclusion or limitation of incidental or consequential damages. This limited warranty gives you specific legal rights, and you may also have other rights which vary from province to province. To know what your legal rights are, consult your local or provincial consumer affairs office.

Warning

This content is compiled from multiple sources and is provided for reference purposes only. It may not be complete or fully applicable to all situations. If you are unable to resolve your issue, please contact the product manufacturer or an authorized service provider for official support.

