

OPERATION

Parts and Functions

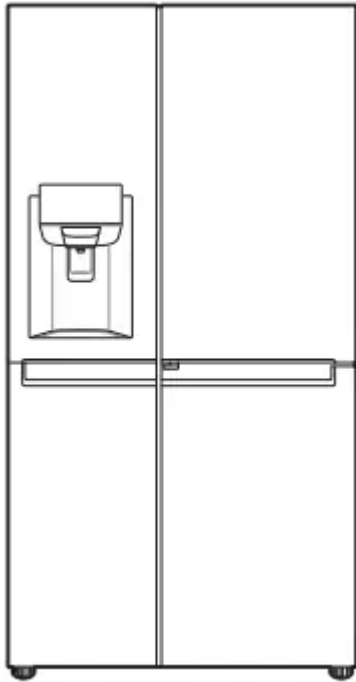

1. Control Panel

To set the freezer and fridge temperatures.

2. Door in Door (Optional)

The Door in Door is a double layered door system. It can be opened individually or together with the main door. You can conveniently locate and access your favourite snacks or food items.

3. Door in Door Lever (Optional)

This lever opens Door in Door.

- The appearance or components of the appliance may differ from model to model.

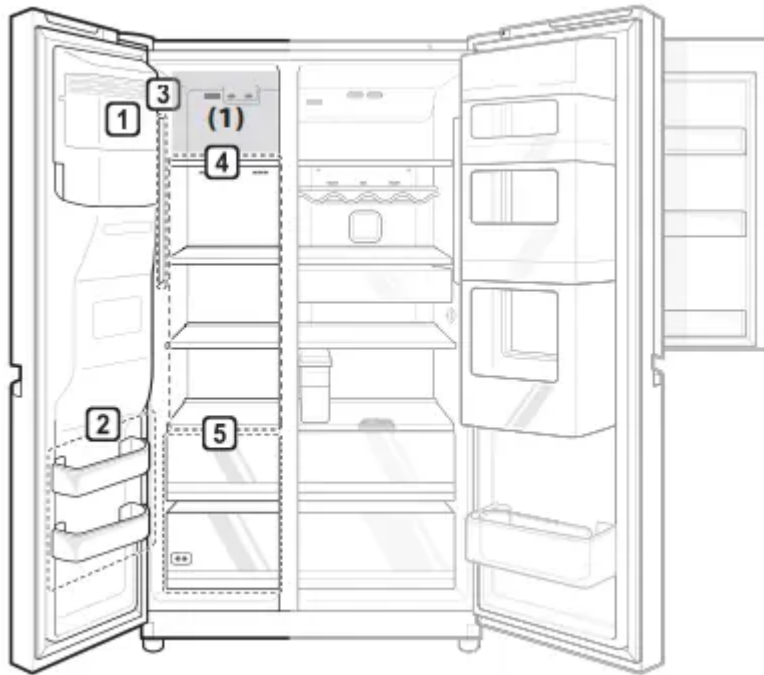

1. Automatic Icemaker

This is where ice is automatically produced and stored.

2. Freezer Door Basket

This is where small packages of frozen food can be stored.

- Do not store ice cream or food which will be stored for a long period of time within these baskets.

3. LED Lamp

The LED lamps inside the appliance light up when you open the door.

4. Freezer Shelf (Optional)

This is where frozen foods such as the meat, fish, and ice cream, can be stored.

5. Freezer Drawer (Optional)

This is for long-term storage of frozen items.

NOTE

- The 2-star section (***) basket or drawer can be used to store ice and food from -12 °C to -18 °C for short periods.
- The top shelf of the freezer(1) will reach the set temperature the most quickly.

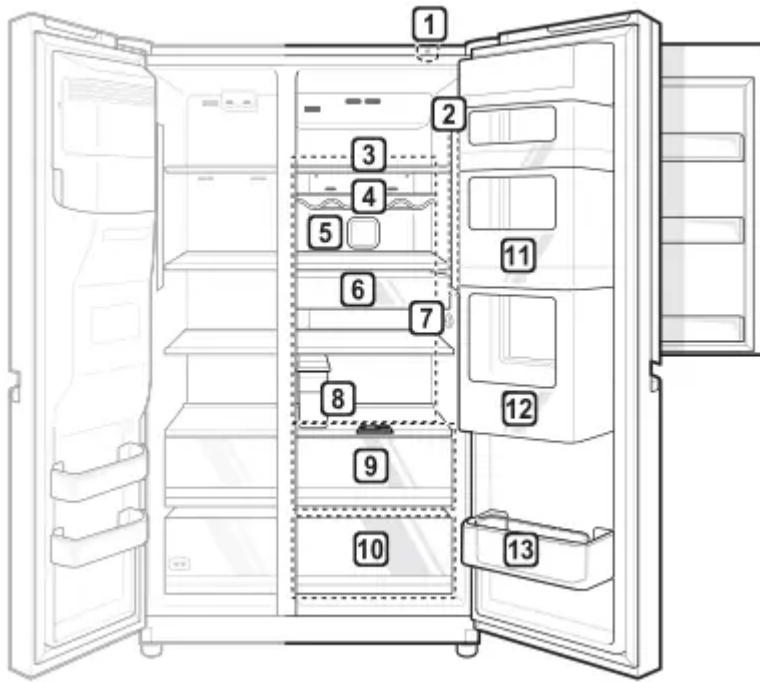

1. Smart Diagnosis Unit

Use this function when contacting LG Electronics customer information centre to help make an accurate diagnosis when the appliance operates abnormally or a failure occurs.

2. LED Lamp

The LED lamps inside the appliance light up when you open the door.

3. Fridge Shelf

This is where refrigerated foods and other items are stored.

- The shelf height can be adjusted by inserting the shelf in another groove of different height.
- Store the foods with higher moisture content at the front of the shelf.
- The actual number of shelves will differ from model to model.

4. Bottle Rack (Optional)

This is where drinks tall bottles or containers are stored.

CAUTION Do not store short bottles or containers. The items may fall and cause an injury or appliance damage.

5. Pure N Fresh

This function reduces and removes odors inside the fridge compartment.

6. Snack Drawer (Optional)

This is where small packages of refrigerated foods are stored.

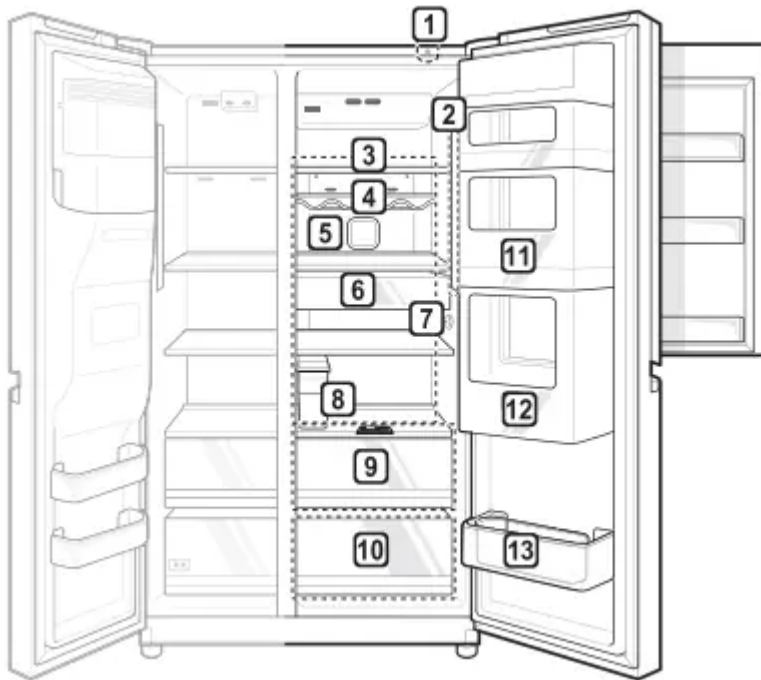

7. Temperature Sensor

This sensor senses the temperature of the fridge compartment.

- Maintain the distance between the sensor and food to accurately sense the temperature.

8. Water Dispenser Tank (Optional)

This is where water to supply the dispenser or the automatic icemaker is stored. It requires manual filling. (Non plumbed models only)

9. Fresh Vegetable Drawer (Optional)

This is where fruits and vegetables are stored to help maintain freshness by adjusting the humidity controller.

10. Vegetable Drawer

This is where fruits and vegetables are stored to remain fresh for as long as possible.

- The actual number of drawers will differ from model to model.

11. Door in Door (Optional)

This is where foods which are taken out frequently such as beverages and snacks are stored.

12. Movable Egg Box (Optional)

This is where eggs are stored.

- You can move it to and use it at a desired position as needed. However, do not use it as the ice bin or place it on the shelf on top of the fridge or the vegetable drawer.

13. Fridge Door Basket

This is where small packages of refrigerated foods, drinks and sauce containers are stored.

Notes for Operation

- Do not use the ice water dispenser tank for beverages other than drinking water.
- Users should keep in mind that frost can form if the door is not closed completely, if the humidity is high during the summer, or if the freezer door is opened frequently.
- Ensure there is sufficient space between food stored on the shelf or door basket to allow the door to close completely.
- Opening the door lets warm air enter the appliance, and may cause the internal temperature to rise.
- Do not open or close the appliance door excessively.
- The LED lamp is only intended for use in domestic appliances and is not suitable for household room illumination.

Suggestion for Energy Saving

- Ensure there is sufficient space between stored foods. This allows cold air to be circulated evenly and lowers electricity bills.
- Store hot food only after it has cooled in order to prevent dew or frost.
- When storing food in the freezer compartment, set the freezer temperature lower than the temperature indicated on the appliance.
- Do not set the temperature of the appliance lower than needed. For ice making in normal climates, the freezer temperatures should be set to -19 or colder.
- Do not put food near the temperature sensor of the fridge compartment. Keep a distance of at least 3 cm from the sensor.
- Please note that a temperature rise after defrosting has a permissible range in the appliance specifications. If you wish to minimise the impact this may have on the food storage due to a temperature rise, seal or wrap the stored food in several layers.

Storing Foods Effectively

- Store frozen food or refrigerated food inside sealed containers.
- Check the expiration date and label (storage instructions) before storing food in the appliance.

- Do not store food for a long period of time (more than four weeks) if it spoils easily at a low temperature.
- Place the refrigerated food or frozen food in each fridge or freezer compartment immediately after purchasing.
- Avoid refreezing any food which has been completely thawed. Freezing any food which has been completely thawed again will lower its taste and nutrition.
- Do not wrap and store vegetables with newspaper. Printing material of newspaper or other foreign substances may smear and contaminate food.
- Do not overfill the appliance. Fill less than 70 % of the space. Cold air can not circulate properly if the appliance is overfilled.
- Cool hot food before storing. If too much hot food is placed inside, the internal temperature of the appliance can increase and negatively affect other foods stored in the appliance.
- If you set an excessively low temperature for food, it may become frozen. Do not set a temperature lower than the required temperature for the food to be stored correctly.
- Always keep the appliance clean.

Max Freezing Capacity

- The Express Freeze function will allow the freezer to its maximum freezing capacity. This generally takes up to seven hours, however, it will automatically turn off after a given time and can also be turned off manually at any given time.
- To get better air circulation, insert all inner parts like baskets, drawers, and shelves.

Maximum Storage

- To get better air circulation, insert all drawers.
- If large quantities of food are to be stored, all the freezer drawers shall be taken out of the appliance except the bottom one and the food shall be stacked directly on the freezer shelves are freezer compartment.

NOTE

- To remove the drawers, first pick the food out of drawers. Then use the handle of drawers, pull out the drawers carefully. It may cause injury.
- The shape of each drawer may be different, insert in the right position.

Using Control Panel

Units and Functions

<Type 1>

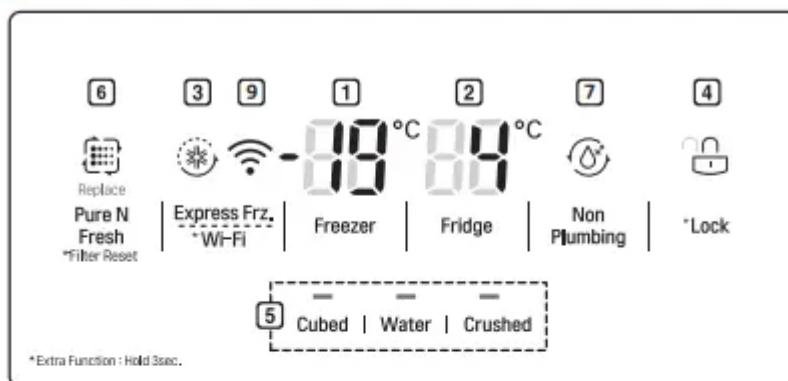

<Type 2>

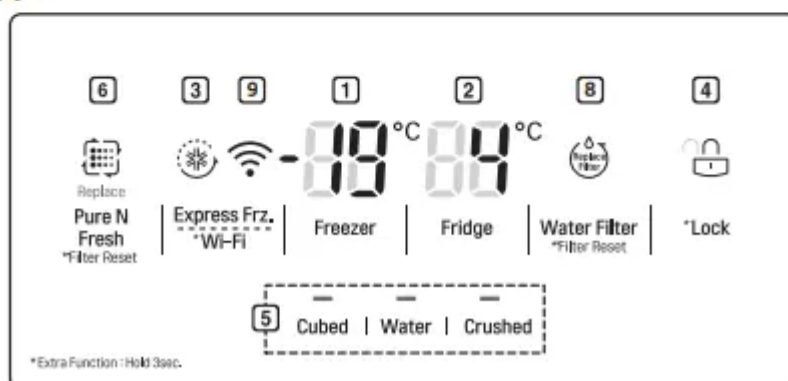

- | | |
|---|---|
| <p>1 Freezer Temperature</p> <ul style="list-style-type: none">• This sets the freezer target temperature. <p>2 Fridge Temperature</p> <ul style="list-style-type: none">• This sets the fridge target temperature. <p>3 Express Freeze</p> <ul style="list-style-type: none">• This sets Express Freeze functions. <p>4 * Lock</p> <ul style="list-style-type: none">• This locks the buttons on the control panel. <p>5 Water Dispenser</p> <ul style="list-style-type: none">• This sets the function of Cubed ice, Water, Crushed ice. | <p>6 Pure N Fresh</p> <ul style="list-style-type: none">• This sets the Pure N Fresh function.• This function reduces and removes odors inside the fridge compartment. <p>7 Non Plumbing (Optional)</p> <ul style="list-style-type: none">• This Non Plumbing icon is illuminated when the water dispenser tank is installed correctly. <p>8 Replacement Filter (Optional)</p> <ul style="list-style-type: none">• This shows the replacement period of the water filter automatically (plumbed models only). <p>9 * Wi-Fi</p> <ul style="list-style-type: none">• This sets the refrigerator to connect to your home's Wi-Fi network. |
|---|---|

- The actual control panel may differ from model to model.

Notes for Use the Control Panel

The control panel will turn on in any of the following cases.

- When the power is turned on
- When a button is pressed
- When the appliance door (fridge compartment, freezer compartment, door in door) is opened

The control panel will turn off automatically for energy saving in any of the following cases.

- When one minute has passed after turning on the power
- When no button operation is carried out for 20 seconds after a desired button is pressed
- When 20 seconds has passed after the appliance door (fridge compartment, freezer compartment, door in door) is opened and closed

If there is any finger or skin contact to the control panel while cleaning it, the button function may operate.

Setting the Temperature

This sets the fridge temperature or freezer temperature.

- Press the Fridge button or Freezer button to adjust the temperature.
- The temperature can be adjusted.
- Fridge : from 1 °C to 7 °C
- Freezer : from -14 °C to -24 °C
- The actual inner temperature varies depending on the food status, as the indicated setting temperature is a target temperature, not actual temperature within the appliance.

NOTE

- The default temperature setting may vary depending on the appliance.
- Wait until two or three hours have passed after connecting the appliance to the outlet before storing food in the appliance.
- The appliance can automatically detect problems during the operation.
- If a problem is detected, the appliance does not operate and an error code is displayed even when any button is pressed.
- When this occurs, do not turn off the power and immediately contact an LG Electronics customer information centre. If you turn off the power, the repair technician from the LG Electronics customer information centre. It may have difficulty finding the problem.

Setting Express Freeze

The function can quickly freeze a large amount of ice or frozen foods.

- When you press the Express Freeze button, the Express Freeze icon lights on the control panel.
- The function is enabled and disabled in turn each time you press the button.
- The Express Freeze function automatically terminates after a specific period has passed.

Setting and Resetting Lock

This locks the buttons on the control panel.

- Press and hold the Lock button for 3 seconds. When the Lock function is set, all buttons are locked.
- When you press the Lock button for 3 seconds, the Lock/Unlock icon on the control panel lights. The function is enabled and disabled in turn each time you press the button.
- If you press a button other than lock when the lock is set, the button will not function.
- When you press a button other than lock when the lock is set, the Lock/Unlock icon on the control panel will flash 3 times.
- To change a setting, first press the Lock button for three seconds to disable the function.

Setting Wi-Fi

The Wi-Fi button, when used with the LG Smart ThinQ application, allows the refrigerator to connect to a home Wi-Fi network.

- The Wi-Fi icon shows the status of the refrigerator's network connection. The icon illuminates when the refrigerator is connected to the Wi-Fi network.
- Press and hold the Wi-Fi button for 3 seconds to connect to the network. The icon blinks while the connection is being made, then turns on once the connection is successfully made.

Water Dispenser Tank (Non plumbed models only)

The water tank holds the water in which is to be dispensed or used by the automatic ice maker to make ice. Do not fill this tank with any other liquid other than water. Doing so can damage the water dispensing system.

1. Remove the water dispenser tank by pulling it out while holding the handle.

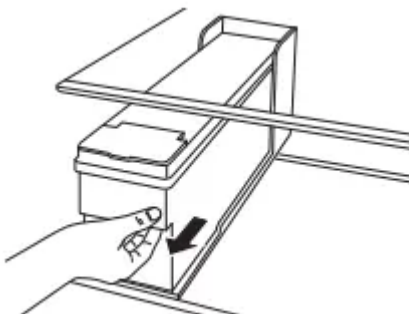

2. Open the cover or cap of the water dispenser tank.

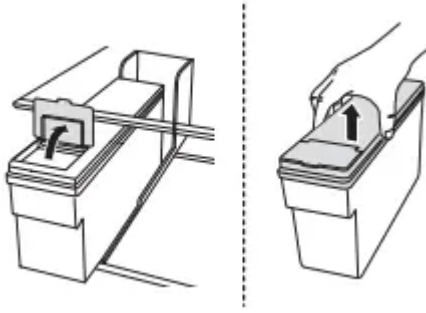

3. Fill with bottle filtered or clean filtered water up to the reference line indicated inside the water dispenser tank. (Total capacity: 4 ℓ)

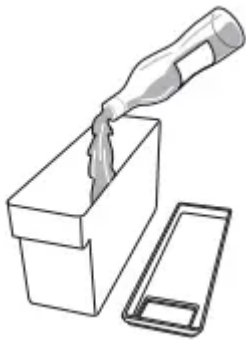

4. After filling with water, close the cover or cap of the water dispenser tank.

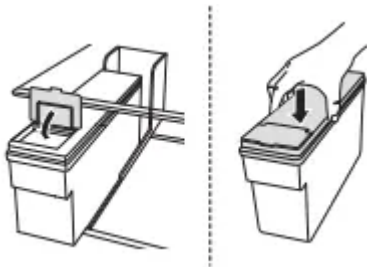

5. Refit the water dispenser tank on the fridge shelf.

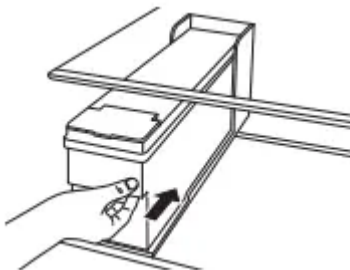

CAUTION

- Children should not be allowed near the dispenser tank. If the child drops the water dispenser tank while it is completely filled with water, injury may occur. Do not fill the water tank with drinks other than water or fill with hot water.

- Do not apply excessive force or impact when removing or assembling the water dispenser tank. Doing so can cause appliance damage or injury.

NOTE

- Before using the water dispenser tank after installing the appliance, it should be washed before filling it with water.
- Check if the water dispenser tank has been placed on the appliance correctly. If it is not assembled correctly, water may leak from the tank into the appliance.
- If there is an insufficient amount of water in the water dispenser tank, ice cube size and quantity may be affected and may result in no ice being made.
- If there is no water in the water dispenser tank, the cold water and ice dispensing function of the dispenser cannot be used. Check if there is water in the water dispenser tank and then fill it with water if there is not.
- Wait at least 15 seconds before removing the water tank after having dispensed water or ice from the dispenser.
- Sound from the water tank will be normal when supplying water to the dispenser and the Automatic Ice Maker. It is not a sign of malfunction.

Water and Ice Dispenser

You can dispense cubed ice, water and crushed ice by pressing the respective button for the desired mode.

- When you press the Cubed, Water or Crushed button on the control panel, the lamp on the control panel will turn on and the desired mode will be set. At this time, when you press the dispenser lever, the selected appliance (cubed ice, water and crushed ice) will be dispensed.
- The function is enabled and disabled in turn each time you press the button on the control panel.

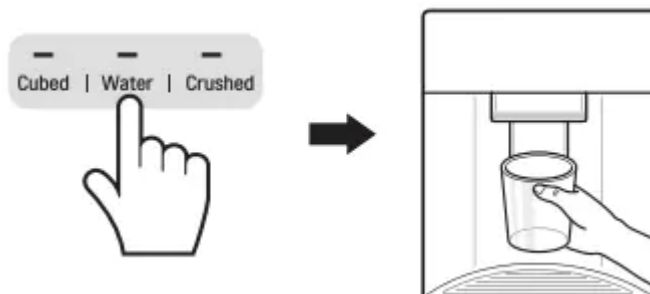

CAUTION

- Keep children away from the dispenser to prevent children playing with or damaging the controls.

- Throw away the first few batches of ice (about 20 cubes and 7 cups of water). This is also necessary if the appliance has not been used for a long time.

NOTE

- If you open the freezer door while water is being dispensed, the water supply will stop and the control panel will return to the initial screen.
- If you open the fridge door while water, cubed ice or crushed ice is being dispensed, dispensing will be paused. When you close the door, the selected item for the previously set mode will continue to be dispensed.
- If the cup rim is small, water may splash out of the glass or miss it completely.
- Use a cup with a rim of over 68 mm in diameter when dispensing water, cubed ice or crushed ice.
- When the ice maker produces smaller ice cubes, or the cubes become lumped together, the amount of water supplied to the ice maker may be low due to insufficient water in the water tank. If ice is not used frequently, it may also lump together.

Automatic Icemaker

The automatic icemaker can automatically make 6 cubes at a time, 50-60 pieces within a 24hr period if conditions are favorable. This amount may vary according to the environment (ambient temperature around the appliance, frequency of the door being opened, amount of food stored in the appliance, etc.).

- If the ice bin is completely filled with ice, ice production will stop.
- Sound of ice dropping into the ice bin is normal.
- The icemaker produces ice normally when approximately 48 hours have passed after the appliance is initially installed.
- Discard ice produced for the first time without using it.
- While the automatic icemaker is operating, do not touch it with your hands directly.
- If ice cubes are stored in the ice bin for a long period of time, they may clump together and may not be separated easily. In such a case, clean the ice bin before using it.

Switching the Automatic Icemaker On and Off

1. Hold and remove the cover of the automatic icemaker by lifting it upward.

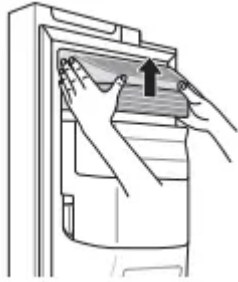

2. When the automatic icemaker is not used, the ice bin can be used as a freezer basket after selecting the icemaker switch to the off position.

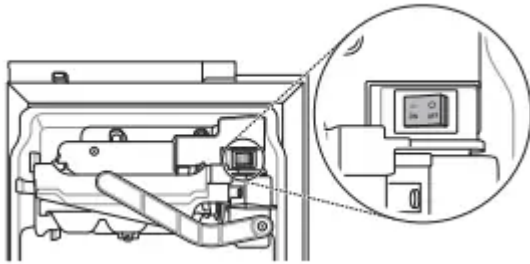

Removing the Ice Bin (Optional)

Hold the ice bin with both hands and pull it out while lifting it upward.

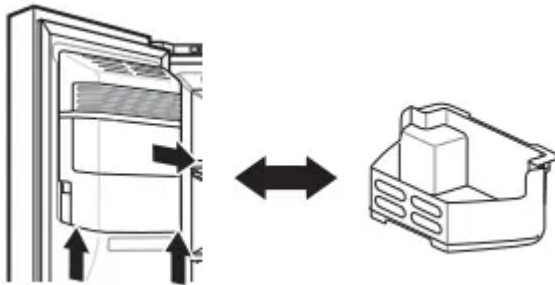

- When the automatic icemaker is not used, the ice bin can be used as a freezer basket.
- If the ice bin is completely filled with ice, it may be heavy. Remove it using both hands.

WARNING

- Do not touch the automatic icemaker mechanical parts with your hand or a tool. Otherwise, appliance damage or injury may occur.
- Caution should be taken, as the automatic icemaker operates continuously after the freezer door is opened when the automatic icemaker switch is set to the on position.
- Do not disassemble, repair or alter the automatic ice maker. These tasks should only be done by a service technician.

CAUTION

- Throw away the first few batches of ice (about 20 cubes and 7 cups of water). This is also necessary if the appliance has not been used for a long time.
- The first ice and water dispensed may include particles or odor from the water supply line or the water tank.
- Keep children away from the dispenser. Children may play with or damage the controls.
- The ice passage may become blocked with frost if only crushed ice is used. Remove the frost that accumulates by removing the ice bin and clearing the passage with a rubber spatula. Dispensing cubed ice periodically can also help prevent frost buildup.
- If discolored ice is dispensed, check the water tank and the water supply for a possible source. If the problem continues, contact the LG Electronics customer information centre. Do not use the ice or water until the problem is corrected.
- Never use thin crystal glass or crockery to collect ice. Such containers may chip or break resulting in glass fragments in the ice.
- Dispense ice into a glass before filling it with water or other beverages. Splashing may occur if ice is dispensed into a glass that already contains liquid.
- Do not touch the ice outlet or the automatic icemaker with your hand or a tool. Otherwise, appliance damage or injury may occur.
- When refitting the ice bin, ensure it is placed correctly. If it is tilted or unlevelled, it may not continue to make ice due to sensor disruption.
- Never use a glass that is exceptionally narrow or deep. Ice may jam in the ice passage and appliance performance may be affected.
- Keep the glass at a proper distance from the ice outlet. A glass held too close to the outlet may prevent ice from dispensing.
- Dispose of the ice inside the ice bin in the freezer compartment if you go out on vacation or an extended power outage occurs. Water from melting ice may drop from the dispenser onto the floor.

Door in Door (Optional)

Press the lever on the lower edge door in door until it opens.

There is plenty of storage space inside the door in door and its surrounding baskets, allowing you to store food in an organized manner.

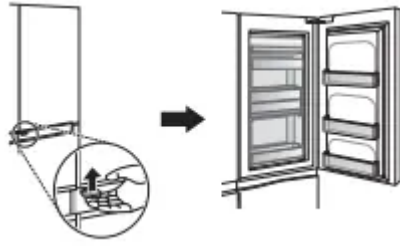

Removing the Case from the Door in Door

Hold the case from inside the door in door with both hands and remove it by lifting it upward.



Refitting the Door in Door Case

Mount them in the reverse order of the removal process.

Removing the Baskets from the Door in Door

1. Hold both edges of the basket and remove it by lifting it upward.

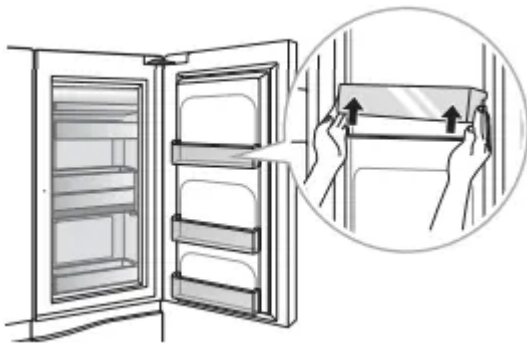

2. Lift the fixed basket up as shown in (1) and remove it by pulling it out as shown in (2).

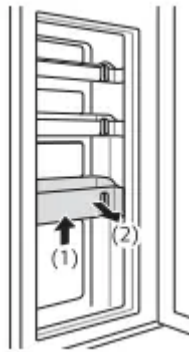

Refitting the Baskets to the Door in Door

Mount them in the reverse order of the removal process.

Fresh Vegetable Drawer (Optional)

The Humidity in the vegetable crisper drawer can be controlled by sliding the lever in either direction.

If moved to the left side, the air guide will be open and allow air to circulate through the drawer for reduced humidity. And if moved to the right side, the air guide will be closed and will maintain any humidity that is currently in the crisper drawer.

The closed state is recommended for storing vegetables, and open state is recommended for storing fruit.

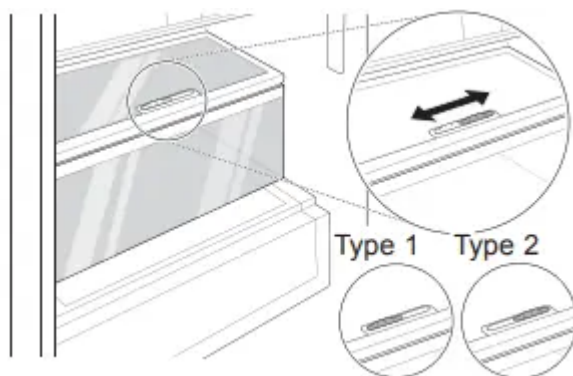

Other Functions

Door Open Alarm

The alarm sounds 3 times in a 30 seconds interval if the door (fridge compartment, freezer compartment, door in door) is left open or not completely closed for one minute.

- Contact an LG Electronics customer information centre if the alarm sound continues even after closing the door.

Failure Detection

The appliance can automatically detect problems during the operation.

- If a problem is detected, the appliance does not operate and an error code is displayed even when any button is pressed.
- When this occurs, do not turn off the power and immediately contact an LG Electronics customer information centre. If you turn off the power, the repair technician from the LG Electronics customer information centre. It may have difficulty finding the problem.

MAINTENANCE

Notes for Cleaning

- When removing a shelf or drawer from inside the appliance, remove all stored foods from the shelf or drawer to prevent injury or damage to the appliance.
 - Otherwise, injury may occur due to the weight of stored foods.
- If cleaning the outside air vents of the appliance by means of vacuuming, then the power cord should be unplugged from the outlet to avoid any static discharge that can damage the electronics or cause an electric shock.
- Detach the shelves and drawers and clean them with water, and then dry them sufficiently, before replacing them.
- Regularly wipe the door gaskets with a wet soft towel.
- Door basket spills and stains should be cleaned as they can compromise storage ability of the basket and could even be damaged.
- After cleaning, check if the power cable is damaged, warm or improperly plugged.
- Keep the air vents on the exterior of the appliance clean.
 - Blocked air vents can cause fire or appliance damage.
- Waxing external painted metal surfaces helps provide rust protection. Do not wax plastic parts. Wax painted metal surfaces at least twice a year using appliance wax (or auto paste wax). Apply wax with a clean, soft cloth.
- For the appliance exterior, use a clean sponge or soft cloth and a mild detergent in warm water. Do not use abrasive or harsh cleaners. Dry thoroughly with a soft cloth.
- Never clean the shelves or containers in the dishwasher.
 - The parts may become deformed due to the heat.
- If the appliance is equipped with an LED lamp, do not remove lamp cover and LED lamp in any attempt to repair or service it. Please, contact an LG Electronics customer information centre.

Replacing the Pure N Fresh Filter (Optional)

To maintain the performance of the Pure N Fresh filter, if a message indicating the filter replacement is displayed, replace the filter as soon as possible.

1. If Replace icon lights on the control panel, replace the Pure N Fresh filter.



2. Hold and remove the Pure N Fresh filter cover by rotating it counterclockwise.



3. Remove the filter inside the Pure N Fresh filter cover and replace it with a new filter.



4. After replacing the filter, insert the Pure N Fresh filter cover by rotating it clockwise.



5. To reset the filter replacement period, press the Pure N Fresh button on the control panel for more than three seconds. The Replace icon on the control panel will turn off.

6. It will operate after replacing the filter.

NOTE

- Do not insert your finger or other foreign objects inside or its mounting. Doing so may result in injuries or malfunctions.
- If the replacement period has passed, the bacteria and odor removal performance may deteriorate.
- Please note that if you wash the filter with water, the filter performance may also deteriorate.
- Caution should be taken not to change the direction of the filter to be inserted into the filter cover.
- When setting the appliance to On or Power mode after replacing the filter, check if the LED lamp near the filter is on.
- The filter can be purchased from an LG Electronics customer information centre.

Cleaning the Door Basket

Removing the Fridge/Freezer Door Basket

Hold both edges of the basket and remove it by lifting it upward.

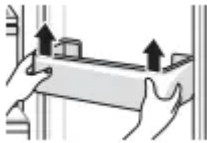

Refitting the Fridge/Freezer Door Basket

1. Hold both edges of the door basket, gently push one edge to assemble, and then in the same manner assemble the other edge.

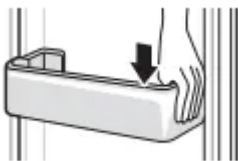

2. After assembling, tap the door basket gently to fix it horizontally

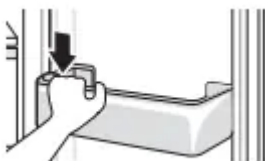

Cleaning the Shelf

Removing the Fridge/Freezer Shelf

Remove the shelf by pulling it out.



Refitting the Fridge/Freezer Shelf

Remove the shelf by pulling it out while slightly lifting the rear edge of the fridge shelf.

Cleaning the Vegetable Drawer

Removing the Vegetable Drawer

1. Remove the contents of the drawer. Hold the handle of the vegetable drawer and pull it out completely until it outward gently until it stops.



2. Lift the vegetable drawer up and remove it by pulling it out.



Refitting the Vegetable Drawer

1. If the vegetable drawer has a cover, lift it.



2. Insert the bottom of the vegetable drawer into its original position and gently push it back in while lowering it.



CAUTION

- Please note that injuries can be caused by the weight of stored foods when removing the vegetable drawer.

Cleaning the Water Dispenser

Cleaning the Dispenser Tray

The dispenser tray may become wet easily due to spilled ice or water. Wipe the entire area with a damp cloth.



Cleaning the Water and Ice Outlet

Wipe the water or ice outlet frequently with a clean cloth as it may get dirty easily. Please note that lint from a cloth may adhere to the outlet.

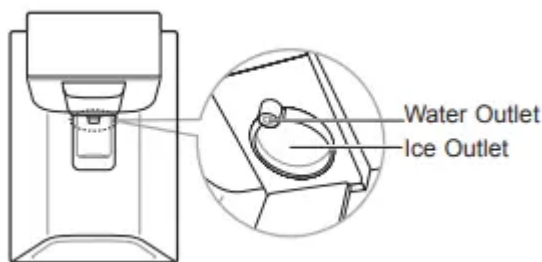

Replacing the Water Filter (For Plumbed models Only)

Replace the disposable water filter when indicated on the Replacement Filter icon or at least every 6 months.

To give you preparation time to get a new filter, the light will come on just before the capacity of the current filter runs out. Changing the filter on time provides you with the fresh and clean water from the appliance.

1. Unplug the appliance.

2. Turn off the water supply to the appliance.
3. Remove the disposable water filter.
4. Install the replacement water filter by following the 'Connecting to the Water Filter' section.
5. Turn on the water supply and switch on the appliance.
6. Press and hold the Water Filter button for three seconds. That resets the Replacement Filter icon. The new water filter has been activated.

TROUBLESHOOTING



Symptoms	Reason	Solution
There is no refrigeration or freezing.	Is there a power interruption?	<ul style="list-style-type: none"> • Check the power of other appliances.
	If the power plug unplugged from the outlet?	<ul style="list-style-type: none"> • Plug the power plug in the outlet properly.
There is poor refrigeration or freezing.	Is the fridge or freezer temperature set to its warmest setting?	<ul style="list-style-type: none"> • Set the fridge or freezer temperature to 'Medium'.
	Is the appliance in direct sunlight, or is it near a heat generating object such as cooking oven or heater?	<ul style="list-style-type: none"> • Check the installation area and reinstall it away from heat generating objects.
	Did you store hot food without cooling it first?	<ul style="list-style-type: none"> • Cool the hot food first before putting it in the fridge or freezer compartment.
	Did you put in too much food?	<ul style="list-style-type: none"> • Maintain an appropriate space between food.
	Are the appliance doors completely closed?	<ul style="list-style-type: none"> • Completely close the door and make sure that stored food is not obstructing in the door.
	Is there enough space around the appliance?	<ul style="list-style-type: none"> • Adjust the installation position to make enough space around the appliance.
The appliance contains a bad smell.	Is the fridge or freezer temperature set to 'Warm'?	<ul style="list-style-type: none"> • Set the fridge or freezer temperature to 'Medium'.

	Did you put in food with a strong smell?	<ul style="list-style-type: none"> • Store foods with strong smells in a sealed containers.
	Vegetables or fruit may have spoiled in the drawer?	<ul style="list-style-type: none"> • Throw away rotten vegetables and clean the vegetable drawer. Do not store vegetables too long in the vegetable drawer.
The inside lamp in the appliance does not turn on.	Does the inside lamp in the appliance turn off?	<ul style="list-style-type: none"> • It is hard for customers to replace the inside lamp in the appliance as they are not serviceable. If the inside lamp does not turn on, please contact the LG Electronics customer information centre.

The appliance door is not closed tightly.	Is the appliance leaning forward?	<ul style="list-style-type: none"> • Adjust the front feet to raise the front side slightly.
	Were the shelves properly assembled?	<ul style="list-style-type: none"> • Refit the shelves if needed.
	Did you close the door with excessive force?	<ul style="list-style-type: none"> • If you apply too much force or speed when closing the door, it may remain briefly open before closing. Make sure that you do not slam the door closed. Close without force.
It is difficult to open the appliance door.	Did you open the door right after you closed it?	<ul style="list-style-type: none"> • If you try to open the appliance door within one minute after you closed it, you may have difficulties because of the pressure inside the appliance. <p>Try to open the appliance door again in a few minutes so that the internal pressure stabilizes.</p>
There is condensation inside the appliance or on the bottom of the vegetable drawer cover.	Did you store hot food without cooling it first?	<ul style="list-style-type: none"> • Cool the hot food first before putting it in the fridge or freezer compartment.
	Did you leave the appliance door open?	<ul style="list-style-type: none"> • Although the condensation will disappear soon after you close the appliance door, you can wipe it with a dry cloth.
	Do you open and close the appliance door too frequently?	<ul style="list-style-type: none"> • Condensation can form due to the temperature difference from the outside. Wipe out the dampness with a dry cloth.
	Did you put warm or moist food inside without sealing it in a container?	<ul style="list-style-type: none"> • Store food in a covered or sealed container.

Frosts has formed in the freezer compartment.	Doors may not be closed properly?	<ul style="list-style-type: none">• Check if the food item inside the appliance is blocking the door and make sure that the door is tightly closed.
	Did you store hot food without cooling it first?	<ul style="list-style-type: none">• Cool the hot food first before putting it in the fridge or freezer compartment.



Frosts has formed in the freezer compartment.	Is the air entry or exit of the freezer compartment blocked?	<ul style="list-style-type: none"> • Make sure that air entry or exit is not blocked so that the air can circulate inside.
	Is the freezer compartment overfilled?	<ul style="list-style-type: none"> • Maintain an appropriate space between items.
Frost or condensation has formed inside or outside the appliance.	Did you open and close the appliance door frequently or is the appliance door improperly closed?	<ul style="list-style-type: none"> • Frosts or condensation can form if the outside air penetrates inside the appliance.
	Is the installation environment humid?	<ul style="list-style-type: none"> • Condensation can appear on the exterior of the appliance if the installation area is too humid or on a humid day such as a rainy day. Wipe off any moisture with a dry cloth.
The appliance is noisy and generates abnormal sounds.	Is the appliance installed on a weak floor or improperly leveled?	<ul style="list-style-type: none"> • Install the appliance on a solid and flat area.
	Does the rear of the appliance touch the wall?	<ul style="list-style-type: none"> • Adjust the installation position to allow enough clearance around the appliance.
	Are objects scattered behind the appliance?	<ul style="list-style-type: none"> • Remove the scattered objects from behind the appliance.
	Is there an object on top of the appliance?	<ul style="list-style-type: none"> • Remove the object on top of the appliance.

<p>The side or front of the appliance is warm.</p>	<p>There are anti condensation pipes fitted to these areas of the appliance to reduce condensation forming from around the door area.</p>	<ul style="list-style-type: none"> • The heat releasing pipe to prevent condensation is installed on the front and side of the appliance. You may feel it particularly hot right after the appliance is installed or during the summer. You can be assured that this is not a problem and is quite normal.
<p>There is water inside or outside of the appliance.</p>	<p>Is there water leakage around the appliance?</p>	<ul style="list-style-type: none"> • Check if the water has leaked from a sink or another place.
	<p>Is there water on the bottom of the appliance?</p>	<ul style="list-style-type: none"> • Check if the water is from the thawed frozen food or a broken or dropped container.

<p>The automatic icemaker does not produce ice or produces a small amount of ice.</p>	<p>Did you install the appliance recently?</p>	<ul style="list-style-type: none"> • The ice maker produces ice normally when approximately 48 hours have passed after the appliance is installed.
	<p>Did you connect the water supply pipe to the appliance and open the supply valve?</p>	<ul style="list-style-type: none"> • Connect the water supply pipe to the appliance and open the supply valve completely.
	<p>Is the water supply hose bent?</p>	<ul style="list-style-type: none"> • If the water supply hose is bent, the water flow could be compromised.
	<p>Have you dispensed a large amount of ice recently?</p>	<ul style="list-style-type: none"> • It takes approximately 24 hours to produce more ice in the automatic icemaker. Please wait.
	<p>Did you set the ice maker switch or the automatic icemaker button on the control panel to ON?</p>	<ul style="list-style-type: none"> • Press I on the automatic icemaker switch or set ON for the automatic icemaker button on the control panel. (For more details on how to use, visit LG electronics website or use your smart device.)
	<p>Is the temperature of the freezer compartment set too high?</p>	<ul style="list-style-type: none"> • If the set temperature is too warm, ice will be produced slowly or not at all. Set the Freezer temperature to -18 °C for normal operation of the automatic icemaker.
	<p>Have you been opening the appliance door frequently?</p>	<ul style="list-style-type: none"> • If you open the appliance door frequently, cold air will escape, lowering the speed of ice production. Do not open and close the appliance door frequently.

	Is the appliance door completely closed?	<ul style="list-style-type: none"> • If the appliance door is not completely closed, the temperature of the freezer compartment will increase, slowing down the ice production speed. Close the appliance door completely.
	Is there ice in the ice bin?	<ul style="list-style-type: none"> • Check whether there is ice in the ice bin.
Ice is not dispensed.	Is the ice clumped in the ice bin?	<ul style="list-style-type: none"> • Separate the ice bin and shake it. Discard the remaining clumped ice after shaking the ice bin.



Ice is not dispensed.	Unable to hear the sound of ice coming out?	<ul style="list-style-type: none"> In the control panel, select the modes for cubed ice and crushed ice alternately to dispense the ice.
	Is the ice path blocked? (You can check the ice passage by separating the ice bin.)	<ul style="list-style-type: none"> Ice may not be dispensed properly if the ice passage is blocked. Check the ice and clean the ice path regularly.
Water does not come out.	The supply valve may be turned off? (For Plumbed models Only)	<ul style="list-style-type: none"> Open the water supply valve.
	The water dispenser tank may be empty? (Non plumbed models only)	<ul style="list-style-type: none"> Fill the water dispenser tank.
	Is the water supply valve closed? (For Plumbed models Only)	<ul style="list-style-type: none"> Open the water supply valve.
	Are you using unfiltered water?	<ul style="list-style-type: none"> Unfiltered water can contain a large amount of various heavy metals or foreign substances, so the filter may be clogged in the early stage regardless of the life of the filter.
Water tastes strange.	Is the taste of water different when comparing it with the taste of water from the previous water purifier?	<ul style="list-style-type: none"> Has the purified water or cold water not been used for an extended period of time?
	Has it been a long time since you installed and replaced the filter?	<ul style="list-style-type: none"> If an expired filter is used, the purification performance may decline. It is recommended to replace the filter according to the filter replacement period.

<p>Have you flushed out the filter properly in the initial stage after installing it?</p>	<ul style="list-style-type: none"> • When you install or replace the filter for the first time, you need to remove air and activated carbon residue from inside the filter. Use the appliance after dispensing and discharging approximately 5 litres of purified water from the dispenser by pressing the water dispensing lever. (Activated carbon is harmless to humans.)
<p>Has the purified water or cold water not been used for an extended period of time?</p>	<ul style="list-style-type: none"> • The taste of old water may change due to bacterial growth. Use the product after dispensing and discharging approximately 5 litres (approximately three minutes) from the water dispenser.



Clicking noises	The defrost control will click when the automatic defrost cycle begins and ends. The thermostat control (or appliance control on some models) will also click when cycling on and off.	<ul style="list-style-type: none"> • Normal Operation
Rattling noises	Rattling noises may come from the flow of appliance, the water line on the back of the unit (for plumbed models only), or items stored on top of or around the appliance.	<ul style="list-style-type: none"> • Normal Operation
	Appliance is not resting evenly on the floor.	<ul style="list-style-type: none"> • Floor is weak or uneven or leveling legs need to be adjusted. See the ' Door Alignment section.
	Appliance with linear compressor was moved while operating.	<ul style="list-style-type: none"> • Normal operation. If the compressor does not stop rattling after three minutes, turn the power to the appliance off and then on again.
Whooshing noises	Evaporator fan motor is circulating air through the fridge and freezer compartments.	<ul style="list-style-type: none"> • Normal Operation
	Air is being forced over the condenser by the condenser fan.	<ul style="list-style-type: none"> • Normal Operation
Gurgling noises	Appliance flowing through the cooling system	<ul style="list-style-type: none"> • Normal Operation
Popping noises	Contraction and expansion of the inside walls due to changes in temperature.	<ul style="list-style-type: none"> • Normal Operation

Vibrating	If the side or back of the appliance is touching a cabinet or wall, some of the normal vibrations may make an audible sound.	<ul style="list-style-type: none">• To eliminate the noise, make sure that the sides and back do not make any contact with any wall or cabinet.
-----------	--	---

Warning

This content is compiled from multiple sources and is provided for reference purposes only. It may not be complete or fully applicable to all situations. If you are unable to resolve your issue, please contact the product manufacturer or an authorized service provider for official support.

