

USER MANUALS

IMPORTANT SAFETY INSTRUCTIONS

READ AND SAVE THESE INSTRUCTIONS

WARNING

When properly cared for, your new appliance has been designed to be safe and reliable. Read all instructions carefully before use. These precautions will reduce the risk of burns, electric shock, fire, and injury to persons. When using kitchen appliances, basic safety precautions must be followed, including those in the following pages.

This appliance is intended for use at an elevation of no more than 2000 meters above sea level.

Proper Installation and Maintenance

WARNING

TIP OVER HAZARD

A child or adult can tip the range over and be killed. Verify that the te the range without the anti-tip bracket in place. Failure to follow the instructions in this manual can result in death or serious burns to children and adults.

Check for proper installation and use of the anti-tip bracket. Carefully tip the range forward pulling from the back to ensure that the anti-tip bracket engages the range leg and prevents tip-over. The range should not move more than 1" (2.5cm).

Have the installer show you the location of the circuit breaker or fuse. Mark it for easy reference. This appliance must be properly installed and grounded by a qualified technician. Connect only to properly grounded outlet. Refer to Installation Instructions for details.

This appliance is intended for normal family household use only. It is not approved for outdoor use. See the Statement of Limited Product Warranty. If you have any questions, contact the manufacturer.

Do not store or use corrosive chemicals, vapors, flammables or nonfood products in or near this appliance. It is specifically designed for use when heating or cooking food. The use of corrosive chemicals in heating or cleaning will damage the appliance and could result in injury.

Do not operate this appliance if it is not working properly, or if it has been damaged. Contact an authorized servicer.

Do not obstruct oven vents.

Do not repair or replace any part of the appliance unless specifically recommended in this manual. Refer all servicing to an authorized servicer.

In the event of an error the display flashes and beeps continuously. Disconnect appliance from the power supply and call an authorized servicer.

WARNING

When removing the door make sure oven is cool and power to the oven has been turned off before removing the door. Failure to do so could result in burns.

The oven door is heavy and fragile. Use both hands to remove the oven door. The door front is glass. Handle carefully to avoid breaking.

Grasp only the sides of the oven door. Do not grasp the handle as it may swing in your hand and cause injury or damage.

Failure to grasp the oven door firmly and properly could result in personal injury or product damage.

Lay the door on a flat smooth surface so that the door cannot fall over. Failure to do so may result in personal injury or damage to the appliance.

WARNING

To avoid injury from hinge bracket snapping closed, be sure that both levers are securely in place before removing door. Also, do not force door open or closed - the hinge could be damaged and injury could result.

WARNING

Make sure the appliance and lights are cool and power to the appliance has been turned off before replacing the light bulb(s). Failure to do so could result in electrical shock or burns.

The lenses (if equipped) must be in place when using the appliance. The lenses (if equipped) serve to protect the light bulb from breaking. The lenses (if equipped) are made of glass. Handle carefully to avoid breaking. Broken glass can cause an injury.

WARNING

Light socket is live when door is open if main power supply is not turned off.

Fire Safety

WARNING

NEVER cover any slots, holes or passages in the oven bottom or cover an entire rack with materials such as aluminum foil. Doing so blocks air flow through the oven. Aluminum foil linings may also trap heat, causing a fire hazard.

If materials inside an oven or warming drawer should ignite, keep door closed. Turn off the appliance and disconnect the circuit at the circuit breaker box.

WARNING

Use this appliance only for its intended use as described in this manual. NEVER use this appliance as a space heater to heat or warm the room. Doing so may result in overheating the appliance. Never use the appliance for storage.

Always have a working smoke detector near the kitchen. In the event that personal clothing or hair catches fire, drop and roll immediately to extinguish flames.

Have an appropriate fire extinguisher available, nearby, highly visible and easily accessible near the appliance. Smother flames from food fires other than grease fires with baking soda. Never use water on cooking fires.

WARNING

TO REDUCE THE RISK OF INJURY TO PERSONS IN THE EVENT OF A GREASE FIRE, OBSERVE THE FOLLOWING:

- a. SMOTHER FLAMES with a close-fitting lid, cookie sheet, or metal tray, then turn off the burner. BE CAREFUL TO PREVENT BURNS. If the flames do not go out immediately, EVACUATE AND CALL THE FIRE DEPARTMENT.
- b. NEVER PICK UP A FLAMING PAN – You may be burned.
- c. DO NOT USE WATER, including wet dishcloths or towels – a violent steam explosion will result.
- d. Use an extinguisher ONLY if:
 - You know you have a Class ABC extinguisher, and you already know how to operate it.
 - The fire is small and contained in the area where it started.
 - The fire department is being called.
 - You can fight the fire with your back to an exit.

Burn Prevention

DO NOT TOUCH HEATING ELEMENTS OR INTERIOR SURFACES OF OVEN - Heating elements may be hot even though they are dark in color. Interior surfaces of an oven become hot enough to cause burns. During and after use, do not touch, or let clothing, potholders, or other flammable materials contact heating elements or interior surfaces of oven until they have had sufficient time to cool. Other surfaces of the appliance may become hot enough to cause burns. Among these surfaces are oven vent openings, surfaces near these openings and oven doors.

Do not touch interior surface of the drawer while it is in use. The interior drawer could become hot enough to cause burns. Allow drawer and rack (if equipped) to cool before handling.

Exercise caution when opening the appliance. Standing to the side, open the door (or drawer) slowly and slightly to let hot air and/or steam escape. Keep your face clear of the opening and make sure there are no children or pets near the unit. After the release of hot air and/or steam, proceed with your cooking. Keep doors shut unless necessary for cooking or cleaning purposes. Do not leave open doors unattended.

Do not heat or warm unopened food containers. Build-up of pressure may cause the container to burst and cause injury.

Use high heat settings on the cooktop only when necessary. To avoid bubbling and splattering, heat oil slowly on no more than a low-medium setting. Hot oil is capable of causing extreme burns and injury.

Use caution when cooking foods with high alcohol content (e.g. rum, brandy, bourbon) in the oven. Alcohol evaporates at high temperatures. There is a risk of burning as the alcohol vapors may catch fire in the oven. Use only small quantities of alcohol in foods, and open the oven door carefully.

Always place oven racks in desired location while oven is cool. Always use oven mitts, when the oven is warm. If a rack must be moved while oven is hot, do not let potholder contact the heating elements. Never move a pan of hot oil, especially a deep fat fryer. Wait until it is cool.

CAUTION

To avoid possible injury or damage to the appliance, ensure rack is installed exactly per installation instructions and not backwards or upside down.

Always use dry potholders. Moist or damp potholders on hot surfaces may result in burns from steam. Do not let potholder touch hot heating elements. Do not use a towel or other bulky cloth.

Secure all loose garments, etc. before beginning. Tie long hair so that it does not hang loose, and do not wear loose fitting clothing or hanging garments, such as ties, scarves, jewelry, or dangling sleeves.

Avoid reaching or leaning over the appliance. Be aware that certain clothing and hair sprays may contain flammable chemicals that could be ignited if brought in to contact with hot surface units or heating elements and may cause severe burns.

Electromagnetic Interference

WARNING

This induction cooktop generates and uses ISM frequency energy that heats cookware by using an electromagnetic field. It has been tested and complies with Part 18 of the FCC Rules for ISM equipment. This induction cooktop meets the FCC requirements to minimize interference with other devices in residential installation. Induction cooktops may cause

interference with television or radio reception. If interference occurs, the user should try to correct the interference by:

- Relocating the receiving antenna of the radio or television.
- Increasing the distance between the cooktop and the receiver.
- Connecting the receiver into an outlet different than the receiver.

It is the user's responsibility to correct any interference.

CAUTION

Persons with a pacemaker or similar medical device should exercise caution when standing near an induction cooktop while it is in use. Consult your doctor or the manufacturer of the pacemaker or similar medical device for additional information about its effects with electromagnetic fields from an induction cooktop.

WARNING

HAZARD DUE TO MAGNETISM The probe is magnetic. The magnetic elements can damage electronic implants such as pacemakers or insulin pumps. People with electronic implants should therefore not put the temperature sensor in the pockets of their clothes and should maintain a minimum distance of 4 inches (10 cm) with respect to their pacemaker or similar medical device.

Child Safety

When children become old enough to use the appliance, it is the responsibility of the parents or legal guardians to ensure that they are instructed in safe practices by qualified persons. Do not allow anyone to climb, stand, lean, sit, or hang on any part of an appliance, especially a door, warming drawer, or storage drawer. This can damage the appliance, and the unit may tip over, potentially causing severe injury.

Do not allow children to use this appliance unless closely supervised by an adult. Children and pets should not be left alone or unattended in the area where the appliance is in use. They should never be allowed to play in its vicinity, whether or not the appliance is in use.

CAUTION

Items of interest to children should not be stored in an appliance, in cabinets above an appliance or on the backsplash. Children climbing on an appliance to reach items could be seriously injured.

Cleaning Safety

WARNING RISK OF BURNS

The appliance will become very hot on the outside during the cleaning function. Never touch the appliance door. Allow the appliance to cool down. Keep children away from the appliance.

Notes

- Do not clean the appliance while it is still hot. Some cleaners produce noxious fumes when applied to a hot surface. Wet cloths or sponges can cause burns from steam.
- When self-cleaning, confirm that the door locks and will not open. If the door does not lock, do not run Self Clean. Contact service.
- Birds have very sensitive respiratory systems. Keep pet birds out of the kitchen or other rooms where kitchen fumes could reach them. During Self Clean, fumes are released that may be harmful to birds. Other kitchen fumes such as overheating margarines and cooking oils may also be harmful.
- Keep oven free from grease build up.

Cookware Safety

Notes

- Do not place food directly on oven bottom.
- Follow the manufacturer's directions when using cooking or roasting bags.
- Hold the handle of the pan when stirring or turning food. This helps prevent spills and movement of the pan.
- Use proper pan size. The use of undersized cookware will expose a portion of the heating element or burner to direct contact and may result in ignition of clothing. Select cookware having flat bottoms large enough to cover the surface heating unit. This appliance is equipped with one or more surface units of different size. Proper relationship of cookware to heating element or burner will also improve efficiency.
- Cookware not approved for use with ceramic cooktops may break with sudden temperature changes. Use only pans that are appropriate for ceramic cooktops. See Cookware Selection Guide.
- Always position handles of utensils inward so they do not extend over adjacent work areas, burners or the edge of the cooktop. This reduces the risk of fires, spills and burns.

CAUTION

Plastic containers or plastic wrap can melt if in direct contact with the drawer or hot utensil. If it melts on to the drawer, it may not be removable.

WARNING

RISK OF INJURY

When cooking with a bain-marie, the cooktop and cooking vessel may crack due to overheating. The cooking vessel in the bain-marie must not come in direct contact with the bottom of the pot filled with water. Use only heat-resistant cookware.

WARNING

DANGER OF INJURY

Cookware may spring or bounce upward due to fluid trapped between the cookware bottom and cooking zone. Always keep cooking zone and cookware bottom dry.

Note: IMPORTANT SAFETY NOTICE: The California Safe Drinking and Toxic Enforcement Act requires the Governor of California to publish a list of substance known to the state to cause cancer, birth defect or other reproductive harm, and requires businesses to warn customers of potential exposure to such substances. The burning of gas cooking fuel and the elimination of soil during self-cleaning can generate small amounts of carbon monoxide. The fiberglass insulation in Self Clean ovens gives off very small amounts of formaldehyde during the first several cleaning cycles. California lists formaldehyde as a potential cause of cancer. Carbon monoxide is a potential cause of reproductive toxicity. Exposure to these substances can be minimized by:

1. Providing good ventilation when cooking with gas.
2. Providing good ventilation during and immediately after self-cleaning the oven.
3. Operating the unit according to the instructions in this manual.

Food Safety

CAUTION

To maintain food safety, follow these guidelines:

- a. DO NOT use a warming drawer to heat cold food. It is safe to use the drawer to crisp crackers, chips or dry cereal and to warm plates.
- b. Be sure to maintain proper food temperature. The USDA recommends holding hot food at 140°F or warmer.
- c. DO NOT warm food for longer than one hour.

Causes of Damage

WARNING

RISK OF INJURY

Exercise caution when opening the appliance. Standing to the side, open the door (or drawer) slowly and slightly to let hot air and/or steam escape. Keep your face clear of the opening and make sure there are no children or pets near the unit. After the release of hot

air and/or steam, proceed with your cooking. Keep doors shut unless necessary for cooking or cleaning purposes. Do not leave open doors unattended.

NOTICES

- DO NOT place accessories or items such as foil, greaseproof paper, oven liners or bakeware on the oven cavity floor. This will cause heat to accumulate. The baking and roasting times will no longer be correct and the enamel will be damaged.
- Aluminum foil in the cooking compartment must not come into contact with the door glass. This could cause permanent discoloration of the door glass.
- Aluminum foil and plastic will melt in hot cooking areas. Stove protective film is not suitable for your cooktop.
- Do not cook on a broken cooktop. Cleaning solutions and spillovers may create risk of electric shock.
- Cookware with rough bottoms will scratch the glass ceramic surface.
- Salt, sugar and grains of sand will scratch the glass ceramic surface. Never use the cooktop as a working surface or for setting things down.
- Avoid heating pots or pans that are empty.
- Hard or sharp objects falling off the cooktop may damage it.
- Sugar and products containing sugar may damage the cooktop. Immediately eliminate spills of these products with a glass scraper once the cooktop has had sufficient time to cool.
- Never set down hot pans and pots on the control panel or frame. This may cause damage.
- Always turn hood ON when cooking at high heat or when flambéing food (i.e. Crepe Suzette, Cherries Jubilee, Peppercorn Beef Flambé).
- When baking particularly juicy fruit pies, do not pack the baking tray too generously. Fruit juice dripping from the baking tray leaves stains that cannot be removed. If possible, use the deeper universal pan.
- If the seal is very dirty, the appliance door will no longer close properly during operation. The fronts of adjacent units could be damaged. Always keep the seal clean.
- Shimmering metallic discolorations on the glass ceramic surface result from the use of inappropriate cleaning agents and abrasion from cookware.
- Do not use the appliance door as a seat, shelf or worktop. Do not place any cookware or accessories on the appliance door.
- Depending on the appliance type, accessories can scratch the door glass when closing the door. Always slide accessories into the cooking compartment as far as they will go.

- Do not carry or hold the appliance by the door handle. The door handle cannot support the weight of the appliance and could break.

Getting Started

Parts

Your appliance may vary slightly

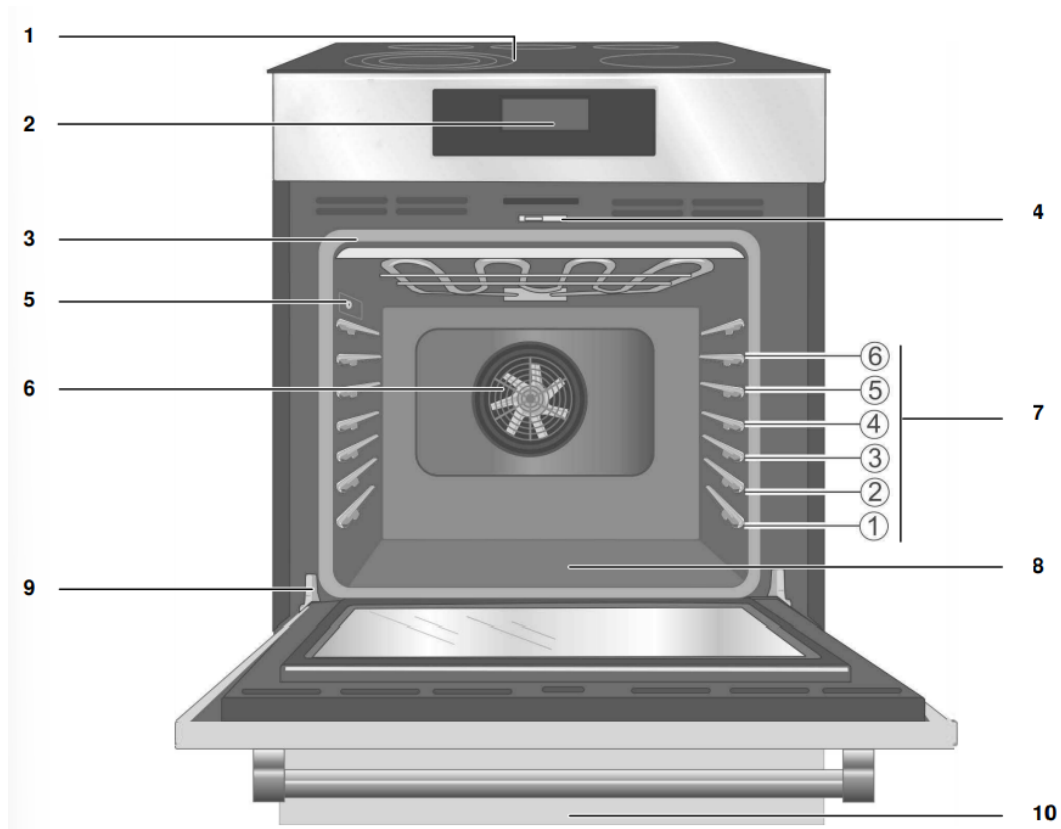

1	Cooktop Control Panel
2	Oven Control Panel
3	Door Gasket
4	Door Latch
5	Probe Jack
6	Convection Fan
7	Rack Position Guides with 6 rack positions
8	Oven Bottom
9	Door Hinge
10	Warming Drawer

Range Features

Retained Heat

The glass cooking surface retains heat and stays hot after the element(s) have been turned off. The retained heat may be used to hold foods at serving temperatures for a short time. If a hot surface light is on, use caution when working or cleaning around the cooktop as the cooktop is still hot.

Hot Surface Indicator

The cooktop displays a hot indicator light to show when the cooking surface is too hot to touch. If a hot surface light is on, use caution when working or cleaning around the cooktop as the cooktop is still hot.

Oven Features

Cooling Fan

The cooling fan runs during all cooking modes. The fan can be heard when it is running, and warm air may be felt as it is released from the oven vent. The fan may also run after the oven is off.

Convection Fan

The convection fan operates during all convection modes. When the oven is operating in a convection mode, the fan turns off automatically when the door is opened. The convection fan may also run during Fast Preheat and Self-Clean.

Oven Bottom

The oven bottom conceals the lower heating element. As a result the element is protected from damage and spills.

Tip: Do not place food directly on the oven bottom.

WARNING Do not use aluminum foil or protective liners to line any part of the appliance, especially the oven bottom. Installation of these liners may result in a risk of electric shock or fire.

Oven Vent

The oven vent is located at the bottom of the unit. Warm air may be released from the vent before, during and after cooking. It is normal to see steam escaping from the vent, and condensation may collect in this area. This area may be warm when the oven is in use. Do not block the vent, since it is important for air circulation.

Automatic Shutoff

The oven will automatically shut off after 24 hours.

Self-cleaning

The oven features a self-cleaning function that eliminates the manual labor involved with cleaning your oven.

Indicators and Other Features

Default Settings-The cooking modes automatically select the default temperature. These can be changed when a different one is needed.

E Number Codes-These codes display when there is a problem with the range.

Standby Mode-Standby mode means that the oven has power but no cooking mode or timer is running.

Accessories

Probe

The probe can be used to determine the internal doneness or the end temperature of many foods, especially meats and poultry.

Do not clean in the Self Clean oven or dishwasher.

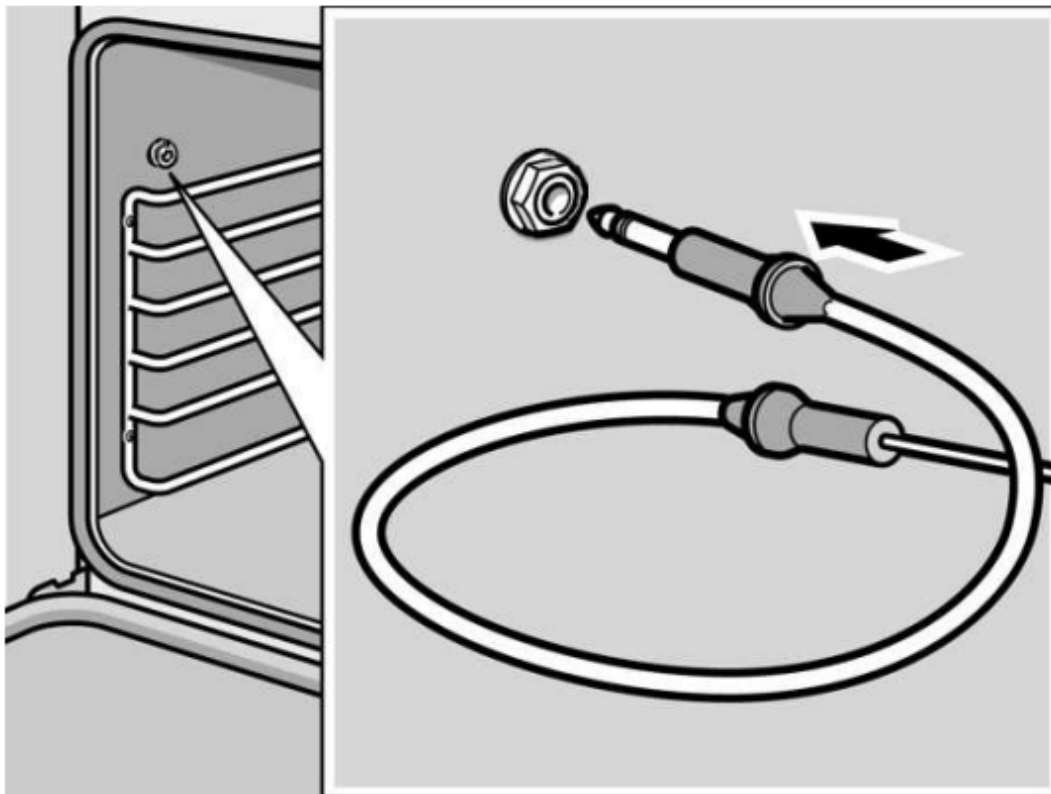

Flat Rack

Use for most cooking. Can use multiple racks in some modes.

Do not clean in the self-clean oven.

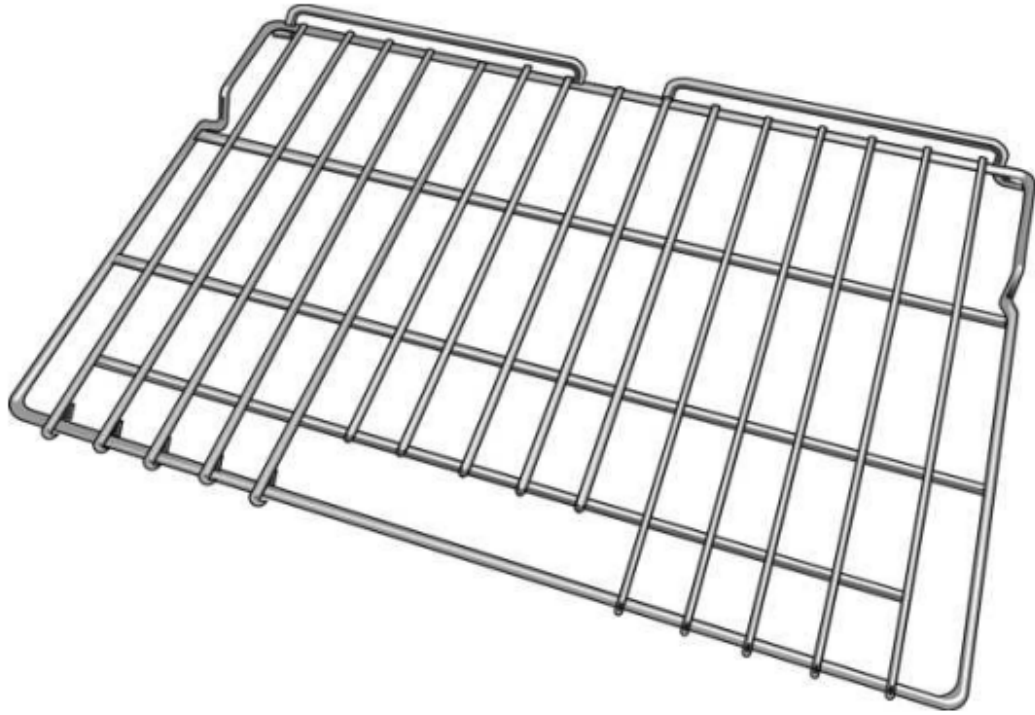

Telescopic Rack (some models)

Additional 30-inch racks available from e-Shop: #HEZTR301

Use with heavier dishes to make easier to place dishes into the oven. Check on food while cooking and remove dishes from oven when done.

Do not clean in the self-clean oven.



Broiling Pan (available from e-Shop) Pan: #00449757 Grill top: #00449756

Use for broiling and roasting.

Do not clean in the self-clean oven.



Inserting Racks

CAUTION

- To avoid burns, place oven racks in desired positions before turning oven on. Always use oven mitts when the oven is warm. If a rack must be moved while the oven is hot, do not let oven mitts contact hot heating elements.
- Use caution when removing oven racks from the lowest rack position to avoid contact with the hot oven door.
- To avoid possible injury or damage to the appliance, ensure racks are installed exactly per installation instructions and not backwards or upside down.

Flat Rack

The rack is designed with a stop so it will stop before coming completely out of the oven and not tilt.

To insert Flat Rack into Oven:

1. Grasp rack firmly on both sides.
2. Insert rack (see picture).

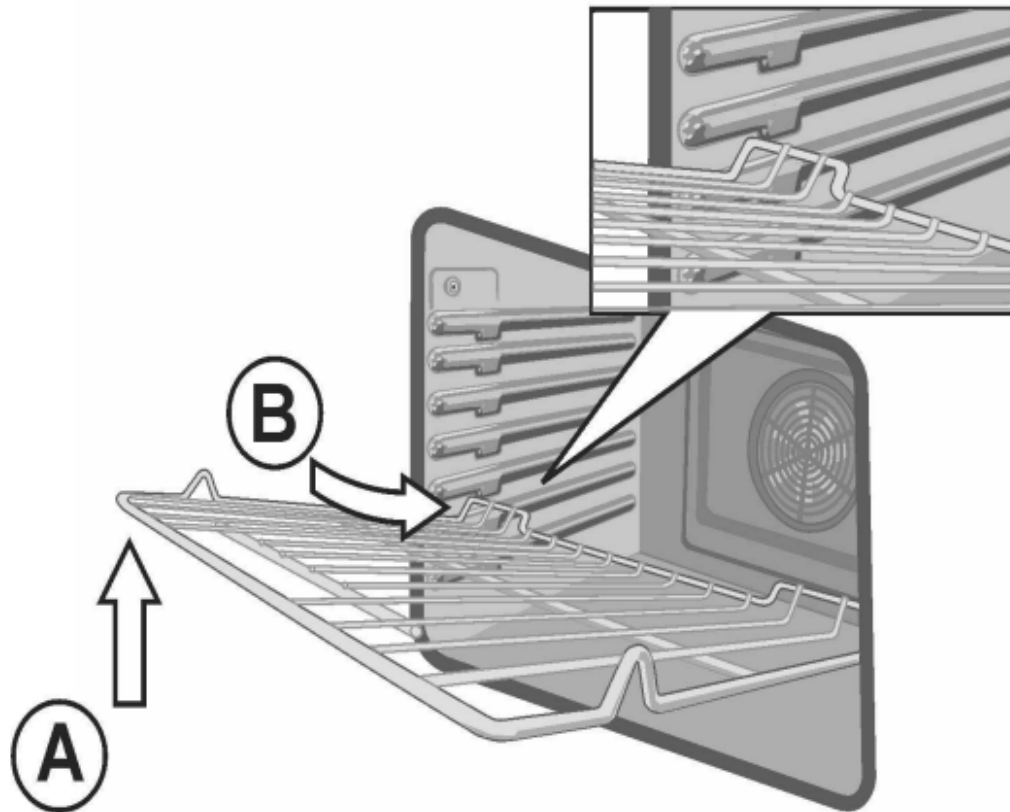

3. Tilt rack up to allow stop into rack guide.
 4. Bring rack to a horizontal position and push the rest of the way in.
- Rack should be straight and flat, not crooked.

To remove Flat Rack from Oven:

1. Grasp rack firmly on both sides and pull rack toward you.
2. When the stop is reached, tilt rack up and pull the rest of the way out.

Telescopic Rack

To insert Telescopic Rack into Oven:

1. Slide the rack in evenly until the rear of the rack is about two (2) inches from the back of the oven.
2. Tilt the front of the rack up about 3/4" (A) and finish pushing the rack all the way back (B).

Note: Avoid striking the oven light cover glass when pushing the rack into position.

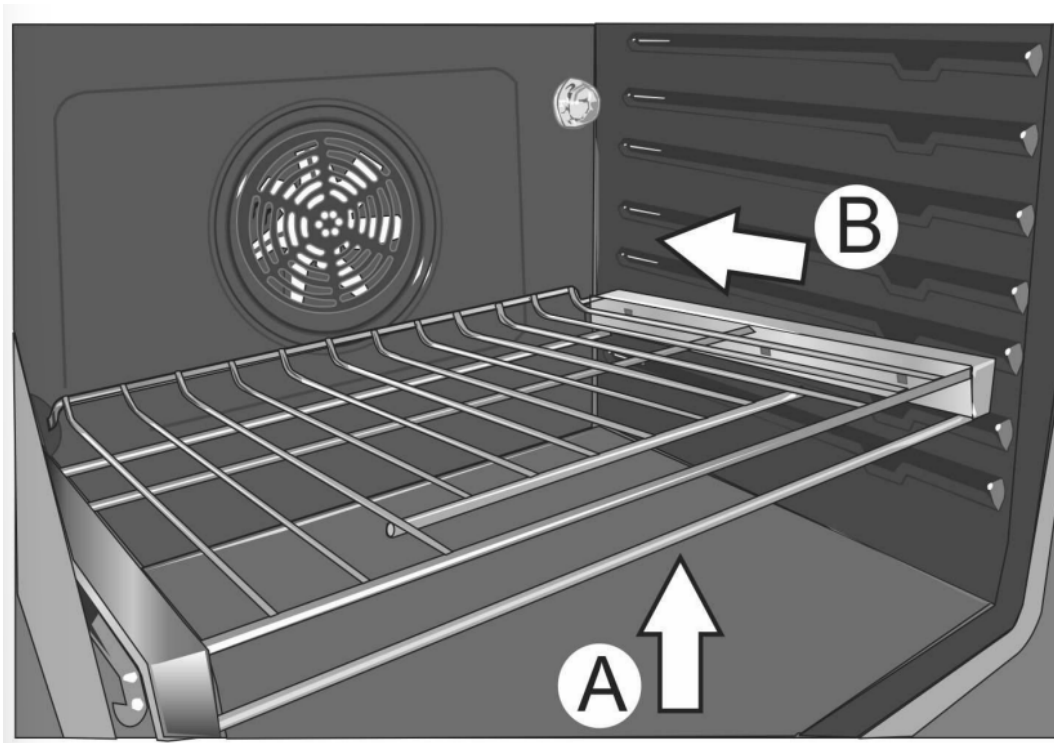

3. The back of the telescopic rack drops in to place.

4. Pull the rack forward to engage the bottom of the rack onto the rear of the rack position guide.

5. Lower the front of the rack to finish seating it on the rack guide. The rack should feel stable when properly seated.

6. Slide the movable part of the telescopic rack in and out a few times to make sure it is able to move freely and that the non-moving part of the telescopic rack is securely anchored.

CAUTION

To avoid possible injury or damage to the appliance, ensure the telescopic rack is installed exactly per installation instructions and not backwards or upside down.

To Remove Telescopic Rack from the Oven:

1. Lift the front of the telescopic rack assembly about 1/2" and push the rack to the rear about 3/4". This allows the rack to disengage from the rack position guide.

2. Lift the rear of the telescopic rack assembly so it clears the rack position guide and gently pull the rack from the oven.

Note: Take care to avoid pulling the rack unevenly which will cause it to bind during removal, catching on the oven walls.

Before Using the Appliance for the First Time

- Remove all packaging materials and labels from the range.
- Range must be properly installed by a qualified technician before use.

- Remove packing materials from inside the oven and inside the drawer.
- While cool, wipe with clean, damp sponge and dry.
- Apply the glass ceramic cooktop cleaner to the glass ceramic cooktop. Buff with a clean cloth. See Care and Cleaning Section.
- There may be a slight odor during first uses. This is normal and will disappear.
- Optimum cooking results depend on proper cookware and bakeware being used.
- The cooking surface will hold the heat and remain hot after the elements have been turned off.
- Read and understand all safety precautions and Use and Care Manual information prior to operating.

Getting familiar with the appliance

In this section we describe the control panel, elements and displays. These instructions apply to more than one cooktop, your appliance might vary slightly.

Control panel (800 Series)

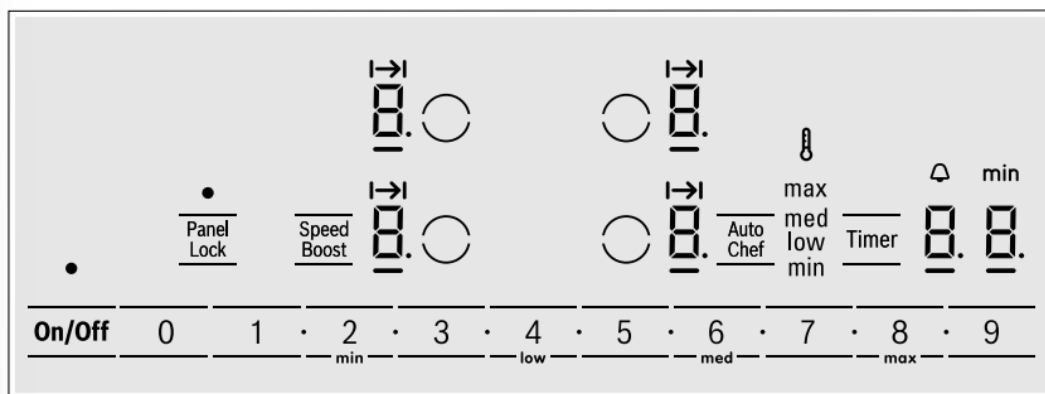

Touch keys	
On/Off	Main switch
○	Select cooking element
0 1 • 2 • ... 8 • 9	Settings area
Panel Lock	Panel lock / Wipe protection
Speed Boost	SpeedBoost® function
Auto Chef	AutoChef® frying function
Timer	Timer functions
min / low / med / max	Select power level for AutoChef®

Display icons	
□	Cooktop ready
●	Indicated function active
→	Cook time set
–	Indicates selected element
00	Timer value
1-9	Power level
H/h	Residual heat
b	SpeedBoost® function
A	AutoChef® function

Display icons	
min	Time display
⌋	AutoChef® temperature
max, med, low, min	Temperature settings
🔔 min	Timer function

Touch control zone

When you touch a symbol, the corresponding function will be activated.

Notes

- When you touch several symbols at once the settings will not change. This enables you to clean the touch control zone when food has spilled over.
- Always keep the touch control zone clean and dry. Moisture and dirt can affect proper functioning.

The elements

Element	
○ Single element	Always use cookware of a suitable size.
Use only cookware suitable for induction cooking; see the section "Cooking with Induction"	

Residual heat indicator

The cooktop has a residual heat indicator for each element. This indicates that the cooktop surface is still hot. Do not touch the cooktop surface while the residual heat indicator is illuminated. The following are shown depending on the amount of residual heat:

- Display H: perature
- Display h: Low temperature

If you remove the cookware from the element during cooking, the residual heat indicator and the selected heat setting will flash alternately.

When the element is switched off, the residual heat indicator will light up. Even after the cooktop has been switched off, the residual heat indicator will remain illuminated for as long as the element is still warm.

Operation

Main power switch

Use the main switch to turn on the electronic circuitry for the control panel. The cooktop is now ready to use.

Turning the cooktop on

Touch the On/Off touch key until the indicator above the main switch and the temperature level indicators < next to the heating elements turn on.

Turning the cooktop off

Touch the On/Off touch key. The ___ indicator goes out. The cooktop is switched off. The residual heat indicators will remain on until the elements have cooled off sufficiently.

Note:

The cooktop switches off automatically when all the elements have been switched off for more than 20 seconds.

The residual heat indicator remains lit until the elements have cooled down sufficiently. •/œ is displayed next to the corresponding element symbol.

Setting the cooktop

This section will show you how to set the elements. The table contains details on the heat settings for a variety of dishes.

Setting the element

Select the desired heat level using the number keys 1 to 9.

Heat level 1 = minimum power

Heat level 9 = maximum power

Each heat setting has an intermediate level. This level is indicated by û in the element display and is set by touching the û symbols between the number keys.

Selecting the heat level

The cooktop must be turned on.

1. Select the desired element with by touching the \$ symbol on the control panel. In the element display < and the ___ indicator light up.
2. Within the following 10 seconds, set the desired power level using the number keys.

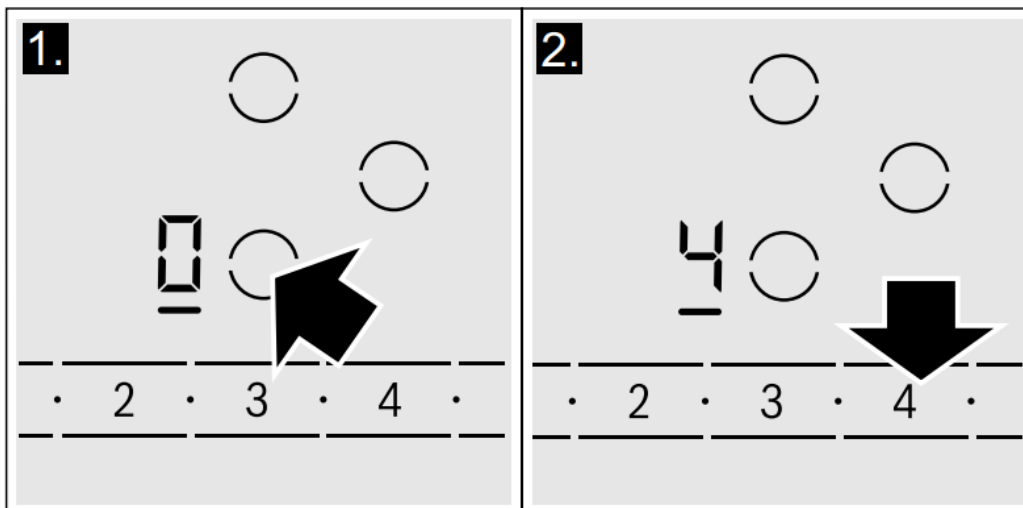

3. To change the power level, select the element and set the desired power level using the number keys. To set an intermediate level touch the û symbols between the number keys.

Turning off the element

Select the element and set the heat level to 0. The element is turned off and the residual heat indicator is displayed.

Notes

- If there is no cookware on the induction cooking zone, the heat setting display blinks. After a while, the cooking zone will switch itself off.
- If cookware has been placed on the cooking zone before you turn on the cooktop, it will be detected within 20 seconds after you have touched the main switch and the cooking zone will be selected automatically. Once detected, set the power level within the next 20 seconds, otherwise the cooking zone will turn off. Even if there are several pots and pans on the cooktop when it is switched on, only one piece of cookware is automatically selected.

Recommendations

- When heating up puree, cream soups and thick sauces, stir occasionally.
- Set heat setting 8 to 9 for preheating.
- When cooking with the lid on, turn the heat setting down as soon as steam escapes between the lid and the cookware.
- After cooking, keep the lid on the cookware until you serve the food.
- To cook with the pressure cooker, observe the manufacturer's instructions.
- Do not cook food for too long, otherwise the nutrients will be lost. The kitchen timer can be used to set the optimum cooking time.
- For healthier cooking results, oil or grease should not be heated until it smokes.
- To brown food, fry small portions in succession.
- Cookware may reach high temperatures while the food is cooking. We recommend that you use pot holders. You can find recommendations for energy-efficient cooking in section "Protecting the Environment".

Settings table

The following table provides some examples. Cooking times may vary depending on the type of food, its weight and quality. Deviations are therefore possible.

CAUTION

During cooking, stews or liquid meals such as soups, sauces or drinks can heat up too quickly unnoticed and overflow or spatter. For this reason we recommend that you stir continuously, gradually heating the food at a suitable power level.

	Power levels
Melting	
chocolate	1
butter	1 - 2
Heating	
frozen vegetables (e.g. spinach)	2 - 3.
broth	7 - 8
thick soup	1. - 2.
milk**	1 - 2
Simmering	
delicate sauce e.g. Béchamel sauce	4 - 5
spaghetti sauce	2 - 3
pot roast	4 - 5
fish**	4 - 5
Cooking	
rice (with double amount of water)	2 - 3
potatoes boiled in their skins with 1-2 cups of water	4 - 5
boiled potatoes with 1-2 cups of water	4 - 5
fresh vegetables with 1-2 cups of water	2 - 3.
frozen vegetables with 1-2 cups of water	3. - 4.
pasta (2-4 qt. water)*	6 - 7
pudding**	1 - 2
cereals	2 - 3

	Power levels
Frying	
pork chop	5. - 6.
chicken breast	5 - 6
bacon	6 - 7
eggs	5 - 6
fish	5 - 6
pancakes	6 - 7
Deep fat frying** (in 1-2 qt. oil)	
deep frozen foods, e.g. chicken nuggets (0.5 lb per serving)	8 - 9
other e.g. doughnuts (0.5 lb per serving)	4. - 5.
Keep warm	
tomato sauce	1.
* ongoing cooking without lid	
** without lid	

Cook time

You can use the timer function to set a cook time for any element. The element will turn off automatically once the set time has elapsed.

CAUTION

When using the timer, always keep an eye on the cooktop and do not allow anything to boil over or burn. Boilovers can cause smoke and foods and oils may catch on fire if left on high temperature settings.

This function should not be used for long periods of time, especially at high heat settings.

Make sure the cooktop is turned off with the main power switch after each use.

Setting a cook time

The cooktop must be turned on.

1. Select the desired element and power level.

2. Touch the Timer key. The x indicator lights up in the element display and << is shown in the timer display.
3. Within 10 seconds enter the desired cook time using the number keys.

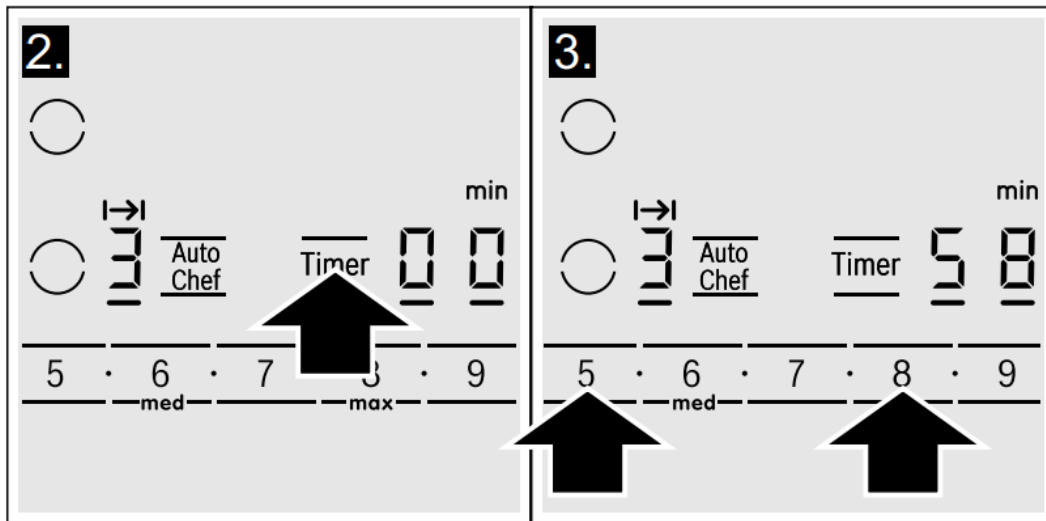

After a few seconds the timer will start to count down.

AutoChef®

If a cooking time has been programmed for an element and AutoChef® has been activated, the cooking time will not begin to count down until the selected temperature setting has been reached.

Changing or canceling cook time

1. Select the desired element and touch the Timer key.
2. Adjust the cook time using the number keys. To cancel cook time set the timer to <<.

Once the cook time has elapsed

The element turns off once the set cook time has elapsed. You will hear a beep. The indicator < appears in the element display and the timer display shows << for 10 seconds. The x indicator in the element display stays on. Touch the Timer key, to turn the indicators and the beep off.

Notes

- To set a cooking time of under 10 minutes, always touch 0 before you select the required value.
- If a cooking time was set for several elements, the time information for the selected element is shown in the timer display.
- Select the relevant element to call up the remaining cooking time.
- You can set a cooking time of up to 99 minutes.

Automatic timer

With this function you may select a cook time for all elements. Once an element is turned on, the selected time will begin to count down. The element will automatically turn off when the cook time has elapsed. Instructions on activating the automatic timer are found in the section on ~ "Basic settings".

Note: The cook time can be changed or canceled for any element:

Select the desired element and touch the Timer key twice. The remaining cook time for the element is displayed. Adjust the cook time using the number keys, or deactivate it by setting the the timer value to 00.

Kitchen timer

The timer can be set for periods of up to 99 minutes. It is independent of the other settings. You can also use the kitchen timer when the cooktop is turned off or locked. This function does not automatically switch off an element.

Setting the kitchen timer

1. Touch the Timer key until the V indicator lights up. << and min appear on the timer display.
2. Set the desired time using the number keys. The timer start to count down after a few seconds.

Changing or deleting the time

Touch the Timer key repeatedly until the V indicator lights up.

Change the time using number keys, or set << in order to delete the programmed time.

When the time has elapsed

A beep sounds. << appears on the timer display and the V indicator lights up. The displays go out after 10 seconds.

When the Timer key is touched, the displays go out and the beep stops.

SpeedBoost® function

The SpeedBoost® function can be used to heat large amounts of water faster than by using heat level 9.

Limitation on use

This function can always be activated for an element, provided the other element in the same group is not in use (see illustration). Otherwise, > and Š will flash in the display for the selected element; heat setting Š will then be set automatically without activating the function.

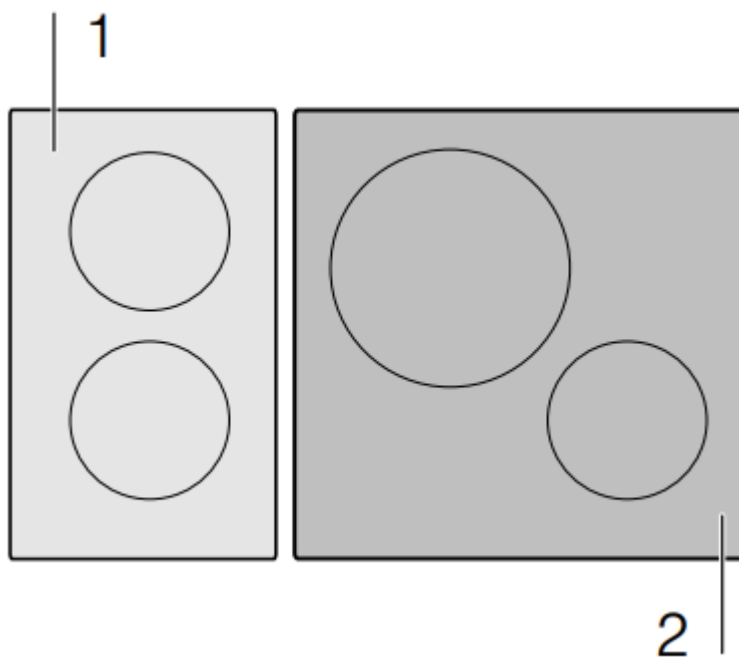

Activation

1. Select an element.
2. Touch the Speed Boost key. 6 lights up on the display.

The function is activated.

Deactivation

1. Select the element on which SpeedBoost® is set.
2. Touch the Speed Boost key. > goes out on the display and the element switched back to heat setting Š.

The function is deactivated.

Note: In certain circumstances, the function may be deactivated automatically to protect the internal electronic components of the cooktop.

AutoChef®

When you are using AutoChef® to operate the heating element, a sensor controls the temperature of the pan.

Advantages when frying

The element only heats up if this is required to maintain the temperature. This saves energy and prevents the oil or fat from overheating.

The AutoChef® function beeps when the empty frying pan has reached the optimum temperature for adding oil and then for adding the food.

CAUTION

- Never leave oil or fat cooking unattended.
- Place the pan in the center of the element. Make sure that the base of the pan has the proper diameter.
- Do not cover the pan with a lid. The automatic regulation will not work. A splash guard can be used without affecting the automatic regulation.
- Only use fat or oil that is suitable for frying. When you are using butter, margarine, olive oil or pork lard, select the min temperature setting.
- AutoChef® is not suitable for boiling.

Suitable pans for AutoChef®

Suitable frying pans for use with AutoChef® are available as optional accessories. Only use pans that are suitable for use with AutoChef®. You can buy our system pans in specialized stores, or through our Customer Support. Always indicate the related reference code.

- HEZ390210 (Small)
- HEZ390220 (Medium)
- HEZ390230 (Large)

The frying pans have a non-stick coating, which means that very little oil is needed for frying.

CAUTION

- The AutoChef® function was set especially for this type of frying pan.
- Other frying pans may overheat. The temperature can be set higher or lower. Try the lowest heat setting first and then change it according to your requirements.
- Make sure that the diameter of the base of the frying pan corresponds to the size of the element. Place the pan in the center of the element.
- If a different type of pan is used, try it first at the lowest frying level, adjusting it as required. The pans may overheat.

Frying levels

Power level	Temperature	Suitable for
max	high	potato pancakes, sautéed potatoes and rare beef steak
med	medium-high	thin fried foods like frozen pies, cutlets (pork or chicken), vegetables
low	medium-low	thick fried food such as hamburgers and sausages, fish
min	low	omelettes, using butter, olive oil or margarine

Frying chart

The chart lists which heat setting is suitable for each type of food. The frying time may vary depending on the type, weight, size and quality of the food.

The set heat setting varies depending on the frying pan that is used.

Preheat the empty pan; add oil and food after the acoustic signal has sounded.

	Temperature setting	Total frying time from signal (mins.)
Meat		
Cutlet, pork or chicken, plain or breaded	med	6 - 10
Fillet	med	6 - 10
Chops*	low	10 - 15
Cordon bleu	med	10 - 15
Steak, medium rare; 1" (2.5 cm) thick	max	6 - 8
Steak, medium or well-done; 1" (2.5 cm) thick	med	8 - 12
Poultry breast; ¾" (2 cm) thick*	low	10 - 20
Sausages, pre-boiled or raw*	low	8 - 20
Hamburger, meatballs	low	6 - 30
Meatloaf	min	6 - 9
Gyros	med	7 - 12
Ground meat	med	6 - 10
Bacon	min	5 - 8
Fish		
Fish, fried, whole, e.g. trout	low	10 - 20
Fish fillet, with or without breadcrumbs	low - med	10 - 20
Shrimp	med	4 - 8
* Turn several times.		
** Total cooking time per portion. Fry in succession.		

	Temperature setting	Total frying time from signal (mins.)
Egg dishes		
Pancakes**	max	-
Omelette**	min	3 - 6
Fried eggs	min - med	2 - 6
Scrambled eggs	min	4 - 9
French toast**	low	4 - 8
Potatoes		
Fried potatoes; boiled in their skin	max	6 - 12
French fries; made from raw potatoes	med	15 - 25
Potato fritter**	max	2.5 - 3.5
Glazed potatoes	low	15 - 20
Vegetables		
Garlic, onions	min	2 - 10
Squash, egg plant	low	4 - 12
Peppers, green asparagus	low	4 - 15
Mushrooms	med	10 - 15
Frozen products		
Cutlet, pork or chicken	med	15 - 20
Poultry breast*	med	10 - 30
Chicken nuggets	med	10 - 15
Fish fillet, with or without breadcrumbs	low	10 - 20
Fish sticks	med	8 - 12
French fries	max	4 - 6
Stir-fried meals, e.g. fried vegetables with chicken	low	6 - 10
Spring rolls	med	10 - 30
Miscellaneous		
Dry ready meals that require water to be added, e.g. pasta	min	5 - 10
Croutons	low	6 - 10
Almonds/walnuts/pine nuts	med	3 - 15
* Turn several times.		
** Total cooking time per portion. Fry in succession.		

Setting the AutoChef® feature

Select the appropriate frying level from the chart. Place the system pan in the center of the element. The cooktop must be on.



1. Select the element.
2. Touch the AutoChef key. The ' lights up on the element display.
3. Select the desired frying level using the number keys. The symbol lights up on the display. The selected frying level is displayed.

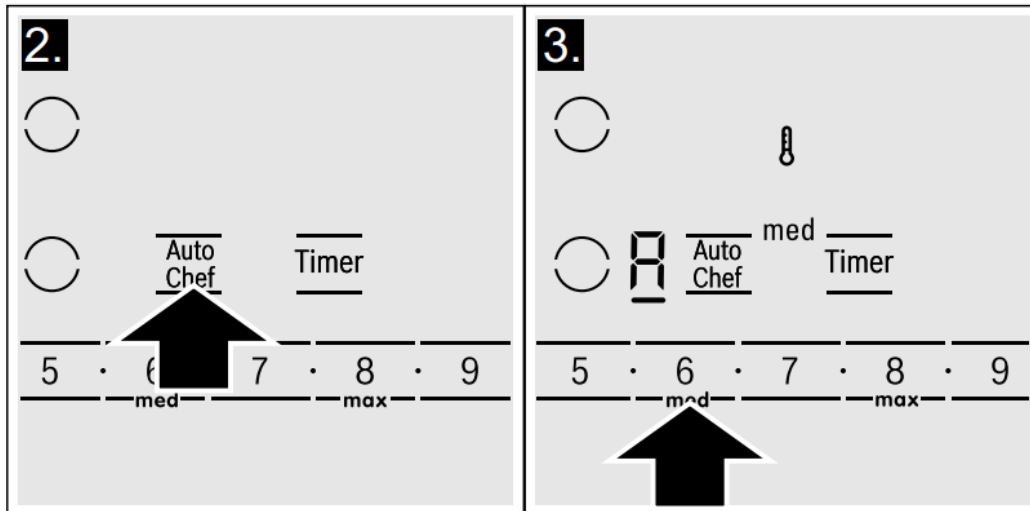

The temperature symbol stays lit until the temperature is reached. Then a beep sounds, s disappears.

4. Add the frying oil to the pan, then add the ingredients. Turn the food over as usual to avoid burning.

Turning off AutoChef®

Select the heating element and touch AutoChef.

Panel lock

You can use the panel lock to prevent the appliance from being turned on accidentally.

Turning the panel lock on

The cooktop must be turned off. Touch Panel Lock for 4 seconds. The indicator over Panel Lock lights up for 10 seconds. The cooktop is now locked.

Turning the panel lock off

Touch Panel Lock for 4 seconds. The panel lock is now deactivated.

CAUTION

The panel lock may be accidentally turned on and off due to:

- water spilled during cleaning
- food that has overflowed
- objects being placed on the Panel Lock key.

Automatic panel lock

With this function, the panel lock is automatically activated whenever you turn off the cooktop.

Switching on and off: You can find out how to switch the automatic panel lock on in the section ~ "Basic settings"

Wipe Protection

Cleaning the control panel while the cooktop is on may change the settings. In order to avoid this the cooktop has a wipe protection function.

To activate: Touch the Panel Lock key. The \cup indicator above the key lights up. The control panel is locked for 35 seconds.

You can now clean the surface of the control panel without risk of changing the settings. To

deactivate: To deactivate the function before the time has elapsed, touch the Panel Lock key. The \cup indicator above the key turns off, the function is deactivated.

Notes

- An acoustic signal sounds 30 seconds after activation. This indicates that the function is about to finish.
- The wipe protection function does not lock the main switch. The cooktop can be switched off at any time.

Automatic time limitation

If the element is used for prolonged periods of time without changes in the settings being made, the automatic time limitation function is triggered.

The element stops heating. ∞ and the residual heat indicator \bullet/∞ flash alternately in the display.

The indicator goes out when any symbol is pressed. The element can now be reset.

When the automatic time limitation is activated depends on the selected heat level (from 1 to 10 hours).

Basic settings

The appliance has various basic settings. You can adjust these settings to the way you usually cook.

Display	Function
c 1	Automatic panel lock 0 Off* 1 On
c 2	Audible signals 0 Confirmation signal and error signals deactivated 1 Only error signals activated 2 Only confirmation signals activated 3 All signals activated*
c 5	Automatic timer 0 Off* 1-99 Automatic shut-off time
c 6	Length of timer end signal 1 10 seconds* 2 30 seconds 3 1 minute
c 7	Power Management function 0 = Off* 1 = 1.000 W. minimum power 1.= 1.500 W 2 = 2.000 W etc. 9 or 9. = maximum power of the element
c 9	Selection time for heating element 0 Unlimited*: You can adjust the settings of the last heating element used at any time without having to select it again. 1 Restricted: You can adjust the settings for the last heating element used within 10 seconds after selecting it. After that you will have to reselect the heating element before setting it.
c 12	Cookware, Checking result of cooking process 0 Not suitable 1 Not perfect 2 Suitable
c 0	Reset to basic settings 0 Off* 1 Reset the appliance to basic settings

*factory settings

Changing the basic settings

The cooktop must be turned off.

1. Turn on the cooktop with the main switch.
2. Within 10 seconds, touch the Timer key for about 4 seconds.

The first four displays provide product information. Touch the settings area to view the individual displays.

Product information	Display
Directory for the Customer Service Index (K1)	0 1
FD number	Fd
FD number 1	99.
FD number 2	0.5

3. Touching the Timer key again takes you to the basic settings. In the display TM and , light up alternately and in the timer display < lights up as a default setting.

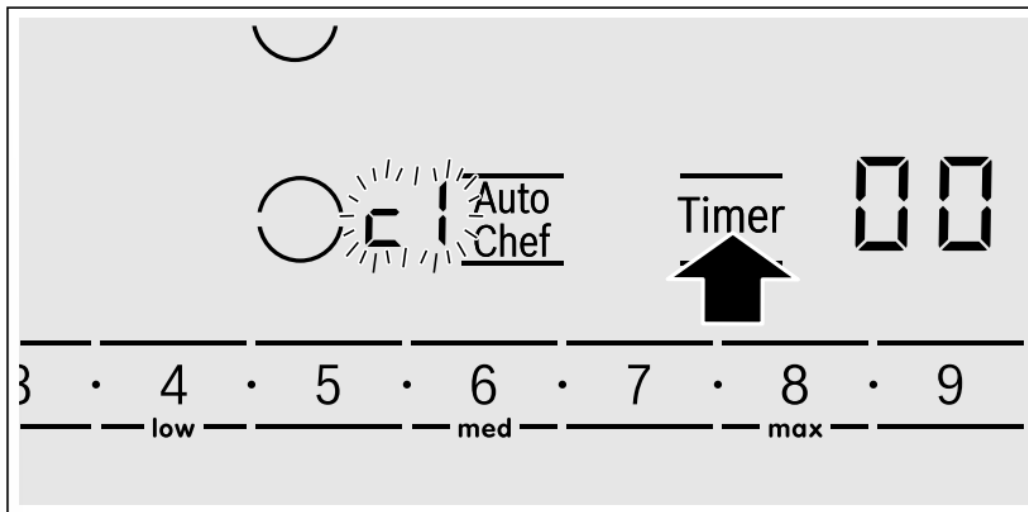

4. Touch Timer repeatedly until the indicator for the desired function appears in the element display.

5. Select the desired setting using the number keys.

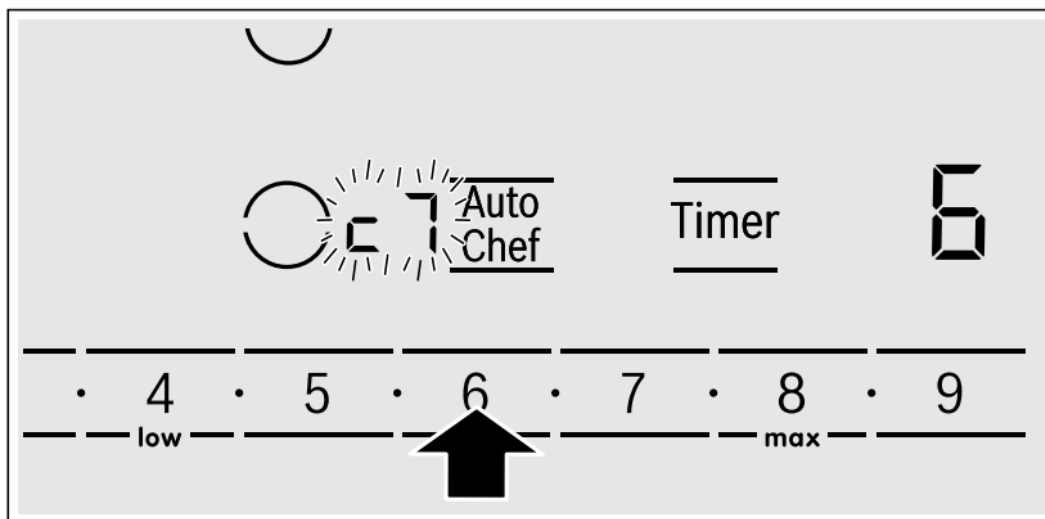

6. Touch Timer again for 4 seconds. The setting is stored.

Quit basic settings

Turn the cooktop off with the main switch.

In this section we describe the control panel, elements and displays.

Control panel (Benchmark Series)

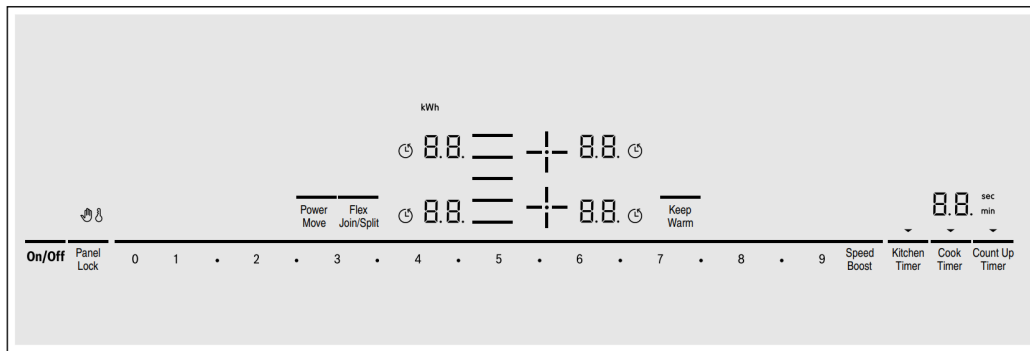

Display icons

	Cooktop ready
	Power levels
	Residual heat
	Time programming functions
	Wipe protection
	Panel lock
	Cook timer
min / sec	Timer indicator
	SpeedBoost® function
	ShortBoost function
kWh	Energy consumption
	Keep Warm function

Touch keys

On/Off	Main switch
	Select a cooking zone
0 1•2•...•8•9	Settings range
Speed Boost	SpeedBoost® and ShortBoost function
Panel Lock	Panel lock/wipe protection
Keep Warm	Keep warm function

Touch keys	
Flex Join/ Split	Flexible cooking zone
Power Move	PowerMove function
Kitchen Timer	Kitchen Timer function
Cook Timer	Setting the cooking time
Count Up Timer	Stopwatch function

Touch controls

When the cooktop heats up, the keys for the touch controls available at this time light up. Touching a key activates the respective function.

Notes

- The corresponding keys for the controls light up depending on whether they are available. The displays for the elements or the selected functions get brighter.
- Always keep the control panel clean and dry. Moisture can prevent it from working properly.

The elements

Element	
○ / □	Single element Use cookware of suitable size.
☐	Flexible cooking zone See section on → "FlexInduction® cooking zone"
Only use suitable cookware for induction cooking; see section on <i>Cooking with Induction</i>	

Residual heat indicator

The cooktop has a residual heat indicator for each element. This indicates that an element is still hot. Do not touch an element while the residual heat indicator is lit up. The following are shown depending on the amount of residual heat:

- Display **H**: High temperature
- Display **h**: Low temperature

If you remove the cookware from the element during cooking, the residual heat indicator and the selected heat setting will flash alternately.

When the element is switched off, the residual heat indicator will light up. Even after the cooktop has been switched off, the residual heat indicator will stay lit for as long as the element is still warm.

Operation

WARNING

BOILOVER HAZARD Never leave surface units unattended at high heat settings. Boilover causes smoking and greasy spillovers that may ignite.

Main power switch

Use the main switch to turn on the electronic circuitry for the control panel. The cooktop is now ready to use.

Turning the cooktop on

Touch the On/Off touch key. An acoustic signal will sound. The ___ indicator located on top of the On/Off touch key and the symbols for the cooking zones light up. <> lights up next to the cooking zones. The cooktop is ready to use.

Turning the cooktop off

Touch the On/Off touch key. The ___ indicator goes out. The cooktop is switched off. The residual heat indicators will remain on until the elements have cooled off sufficiently.

Note: The cooktop switches off automatically when all the elements have been switched off for more than 20 seconds. The residual heat indicator remains lit until the elements have cooled down sufficiently. •/œ is displayed next to the corresponding element symbol.

Setting the cooktop

This section will show you how to set the elements. The table contains details on the heat settings for a variety of dishes.

Setting the element

Select the desired heat level using the number keys 1 to 9.

Heat level 1 = minimum power

Heat level 9 = maximum power

Each heat setting has an intermediate level. This level is indicated by .5 in the element display and is set by touching the Ú symbols between the number keys.

Selecting the heat level

The cooktop must be turned on.

1. Select the desired element with by touching the $\tilde{\alpha}$ or \varnothing symbol of the desired element. In the cooking zone display <.> lights up brighter.
2. Then select the desired power level using the number keys.

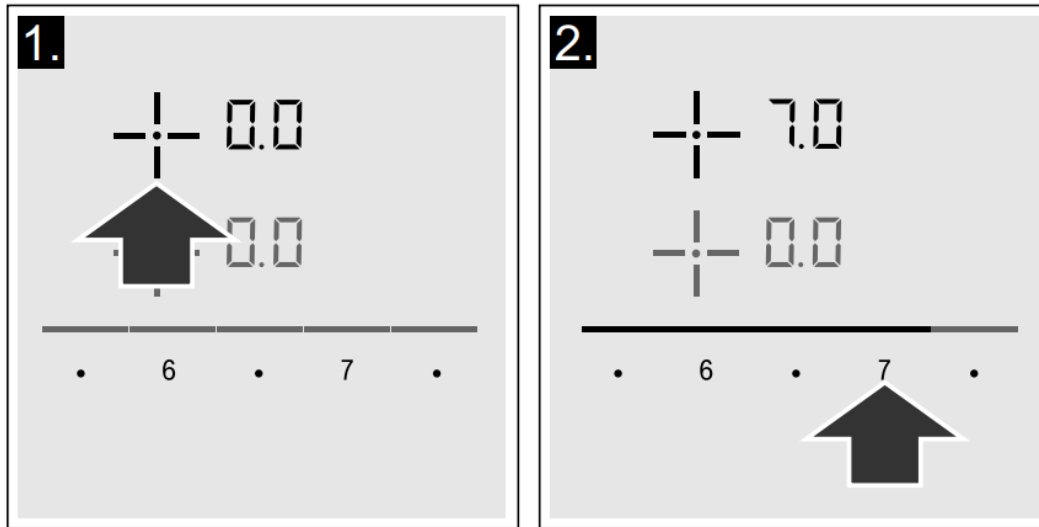

3. The power level is set.

Changing the power level

Select the cooking zone and then set the required power level in the control panel.

Turning off the cooking zone

Select the cooking zone and set the power level to 0. The cooking zone is turned off and the residual heat indicator is displayed.

Notes

- If there is no cookware on the induction cooking zone, the heat setting display blinks. After a while, the cooking zone will switch itself off.
- If cookware has been placed on the cooking zone before you turn on the cooktop, it will be detected within 20 seconds after you have touched the main switch and the cooking zone will be selected automatically. Once detected, set the power level within the next 20 seconds, otherwise the cooking zone will turn off.

Even if there are several pots and pans on the cooktop when it is switched on, only one piece of cookware is detected.

Recommendations for cooking

- Set heat setting 8 to 9 for preheating ; for delicate dishes like milk, pudding, rice pudding or cereals heat up with setting 8 - 8.5.
- When cooking with the lid on, turn the heat setting down as soon as steam escapes between the lid and the cookware. Steam does not need to escape for a good cooking result.

- After cooking, keep the lid on the cookware until you serve the food.
- To cook with the pressure cooker, observe the manufacturer's instructions.
- Do not cook food for too long, otherwise more nutrients than necessary will be lost. The kitchen timer can be used to set the optimum cooking time.
- For a more healthy cooking result, smoking oil should be avoided.
- To brown food, fry small portions in succession.
- Cookware may reach high temperatures while the food is cooking. We recommend that you use oven mitts.

Settings table

The following table provides some examples. Cooking times may vary depending on the type of food, its weight and quality. Deviations are therefore possible.

CAUTION

During cooking, stews or liquid meals such as soups, sauces or drinks can heat up too quickly unnoticed and overflow or spatter. For this reason we recommend that you stir continuously, gradually heating the food at a suitable power level.

	Power levels
Melting	
chocolate	1.5
butter	1.0 - 2.0
Heating	
frozen vegetables, e.g. spinach	2.5 - 3.5
broth	7.0 - 8.0
thick soup	1.5 - 2.5
milk**	1.0 - 2.0
Simmering	
delicate sauce e.g. Béchamel sauce	4.0 - 5.0
spaghetti sauce	2.0 - 3.0
pot roast	4.0 - 5.0
fish**	4.0 - 5.0
Cooking	
rice (with double amount of water)	2.0 - 3.0
potatoes boiled in their skins (with 1-2 cups of water)	4.0 - 5.0
boiled potatoes (with 1-2 cups of water)	4.0 - 5.0
fresh vegetables (with 1-2 cups of water)	2.0 - 3.5
frozen vegetables (with 1-2 cups of water)	3.5 - 4.5
pasta (with 2-4 qt. water)*	6.0 - 7.0

	Power levels
pudding**	1.0 - 2.0
cereals	2.0 - 3.0
Frying	
pork chop	5.5 - 6.5
chicken breast	5.0 - 6.0
bacon	6.0 - 7.0
eggs	5.0 - 6.0
fish	5.0 - 6.0
pancakes	6.0 - 7.0
Deep fat frying** (in 1-2 qt. oil)	
deep frozen foods, e.g. chicken nuggets (0.5 lb per serving)	8.0 - 9.0
other, e.g. doughnuts (0.5 lb per serving)	4.5 - 5.5
Keep warm	
tomato sauce	1.5

* ongoing cooking without lid
** without lid

FlexInduction® cooking zone

You can combine the elements into a large cooking zone as needed or use two elements that are independent of one another.

The FlexInduction® cooking zone consists of 4 inductors, which are controlled independently of one another. When FlexInduction® is in use, only the area is activated that is covered by cookware.

Cookware use recommendations

Place the cookware in the middle. This guarantees optimal pot detection and heat distribution.

Flexible cooking zone - as an individual element

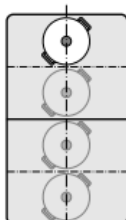

Diameter of the cookware max. 5¹/₈" (13 cm)

Place the cookware on one of the 4 positions visible in the figure.

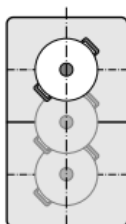

Diameter larger than 5¹/₈" (13 cm)

Place the cookware on one of the 3 positions visible in the figure.

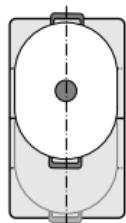

If the cookware takes up more than one element, place it on the upper or lower edge of the flexible cooking zone.

Flexible cooking zone - two independent elements

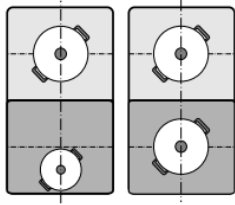

The front and rear elements with two inductors apiece can be used independently. The heat setting is set individually for each element. Use only one piece of cookware on each element.

As two independent elements

The flexible cooking zone is used like two independent elements.

Turning on

See section on ~ "Setting the cooktop".

As a single element

Using the entire cooking zone by connecting both elements.

Linking the two elements

The cooktop must be turned on.

1. Set down the cookware. Select one of the two elements assigned to the flexible cooking zone and set the power level.
2. Touch the Flex Join/Split key. The display lights up. The heat setting appears in the display for the lower element.

The flexible cooking zone is activated.

Changing the power level

Select one of the element in the flexible cooking zone and change the power level with the number keys.

Add another piece of cookware

Set the new item of cookware down on the cooktop, select one of the two elements in the flexible cooking zone and then touch the Flex Join/Split key twice. The new item of cookware will be detected and the power level that was previously selected will be retained.

Note: If the cookware is moved to the element being used or lifted up, the element begins an automatic search and the heat setting selected previously is retained.

Separating the two elements

Select one of the two elements in the flexible cooking zone and touch the Flex Join/Split key.

This deactivates the flexible cooking zone. The two elements will now function independently.

Notes

- If the element is switched off, and then switched back on again later, the flexible cooking zone is reset to function as two independent elements.
- To change the configuration settings for the flexible cooking zone, refer to the section on ~ "Basic settings".

PowerMove function

This function activates the entire flexible cooking zone, which is divided into three cooking areas and which has preset power levels.

Only use one item of cookware. The size of the cooking area depends on the cookware used and whether it is positioned correctly.

Cooking areas

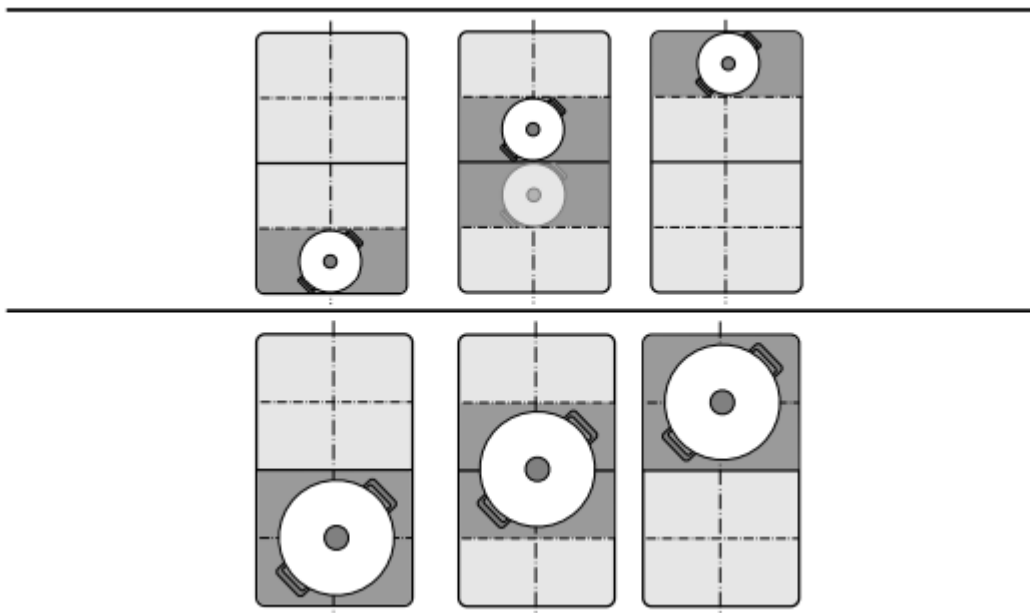

This means that an item of cookware can be moved during the cooking process to another cooking area with another power level:

Notes

- If more than one item of cookware is detected on the flexible cooking zone, the function is deactivated.
- If the cookware is moved within the flexible cooking zone or lifted up, the cooktop automatically starts searching and the power level of the area in which the cookware was detected is set.
- You can find information on the size and positioning of the cookware in the section on the function ~ "FlexInduction® cooking zone".

Activation

1. Select one of the two elements in the flexible cooking zone.
2. Touch the Power Move key. The indicator beside the Power Move key lights up. The flexible cooking zone is activated as a single cooking zone. The power level in the area in which the cookware is located lights up in the cooking zone display.

The function has now been activated.

Changing the power level

The power levels for the individual cooking areas can be changed during the cooking process. Set the cookware down on the cooking area and change the power level using the number keys.

Notes

- Only the power level in the area in which the cookware is located is changed.
- If the function is deactivated, the power levels for the three cooking areas are reset to the preset values. Deactivating Touch the Power Move key. The indicator beside the Power Move key goes out. The function was deactivated. Note: If one of the cooking areas is set to <, the function deactivates after a few seconds.

Time-setting options

Your cooktop has three timer functions:

- Programming the cooking time
- Kitchen timer
- Stopwatch function

Programming the cooking time

The element automatically switches off after the set time has elapsed.

Setting procedure:

1. Select the element and the required power level.
2. Touch the Cook Timer key. The << symbol and the V indicator light up in the Cook Timer display. y lights up in the display for the element.

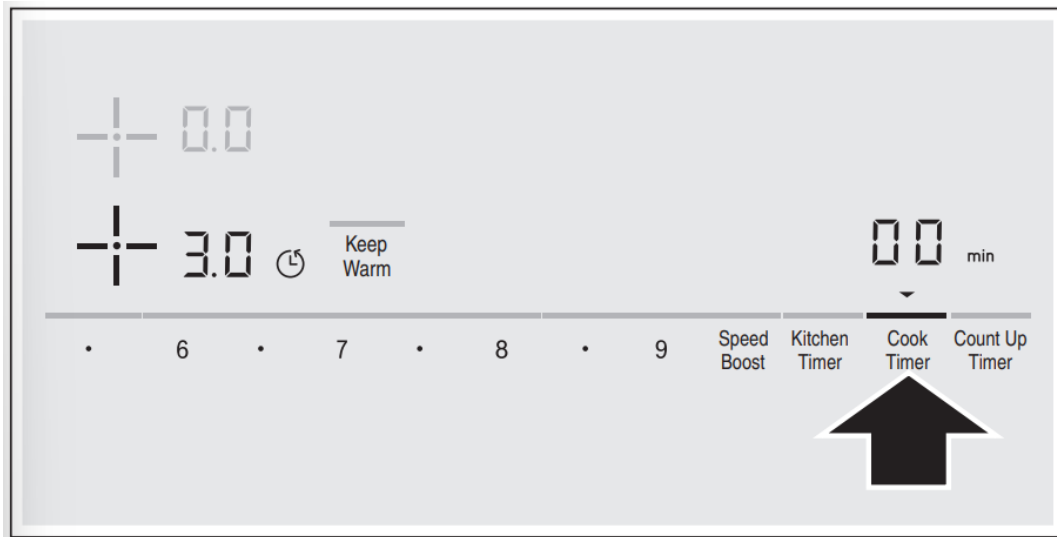

3. Within the next 10 seconds, set the required cooking time using the number keys.

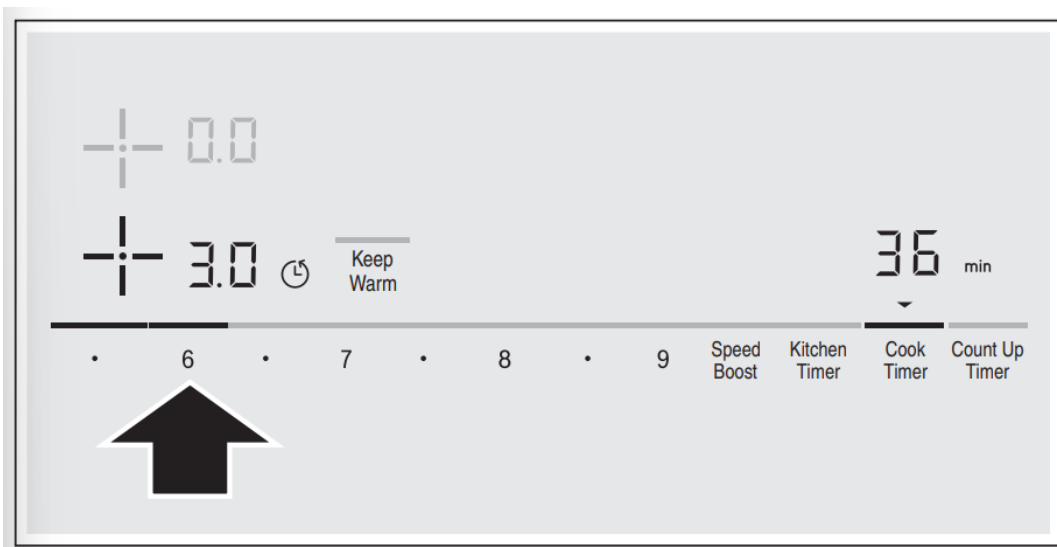

4. Touch the Cook Timer key to confirm the selected setting.

The cooking time begins to elapse.

Notes

- The same cooking time can be set automatically for all elements. The set time for each of the elements counts down independently. You can find information on automatically programming the cooking time in section on “Cook timer”.
- If the flexible cooking zone is selected as the only element, the set time for the entire cooking zone is the same.
- If the Move function is selected for the combined cooking zone, the set time for the three elements is the same.

Changing or deleting the time

Select the element and then touch the Cook Timer key. Change the cooking time using the number keys or set << to delete the programmed cooking time. Touch the Cook Timer key to confirm the selected setting.

When the time has elapsed

The element switches off, the y display flashes and the element switches to power level <<. An acoustic signal sounds.

<< and the V indicator flash in the timer display. When the y symbol is touched, the indicators go out and the acoustic signal ceases.

Notes

- To set a cooking time of under 10 minutes, always touch 0 before you select the required value.
- If a cooking time was set for several elements, the time information for the selected element is shown in the timer display.
- Select the relevant element to call up the remaining cooking time.
- You can set a cooking time of up to ŠŠ minutes.

Kitchen timer

The timer can be set for periods of up to 99 minutes. It is independent of the other settings. You can also use the kitchen timer when the cooktop is turned off or locked. This function does not automatically switch off an element.

Setting procedure

1. Touch the Kitchen Timer key. The << symbol and the V indicator light up in the timer display.
2. Select the required time on the control panel and touch the Kitchen Timer key to confirm.

After a few seconds, the time begins to elapse.

Changing or deleting the time

Touch the Kitchen Timer key.

Change the cooking time using the number keys or set << to delete the programmed cooking time. Touch the Kitchen Timer key to confirm the selected setting.

When the time has elapsed

An audible signal sounds once the time has elapsed. << and the V symbol flash in the timer display. The indicators go out after touching the Kitchen Timer key.

Count-up timer function

The count-up timer function displays the time that has elapsed since activation. This functions independently from the elements and from other settings. This function does not automatically switch off an element.

Activating

Touch the Count Up Timer key. The << symbol and the V indicator light up in the timer display. The time begins to count up.

Deactivating

Touching the Count Up Timer key the stopwatch function. The timer displays remain lit. If you touch the Count Up Timer key again, the displays go out. The function is deactivated.

SpeedBoost® function

The SpeedBoost® function enables you to heat up large quantities of water faster than when using heat setting 5. This function can always be activated for an element, provided the other element in the same group is not in use (see illustration).

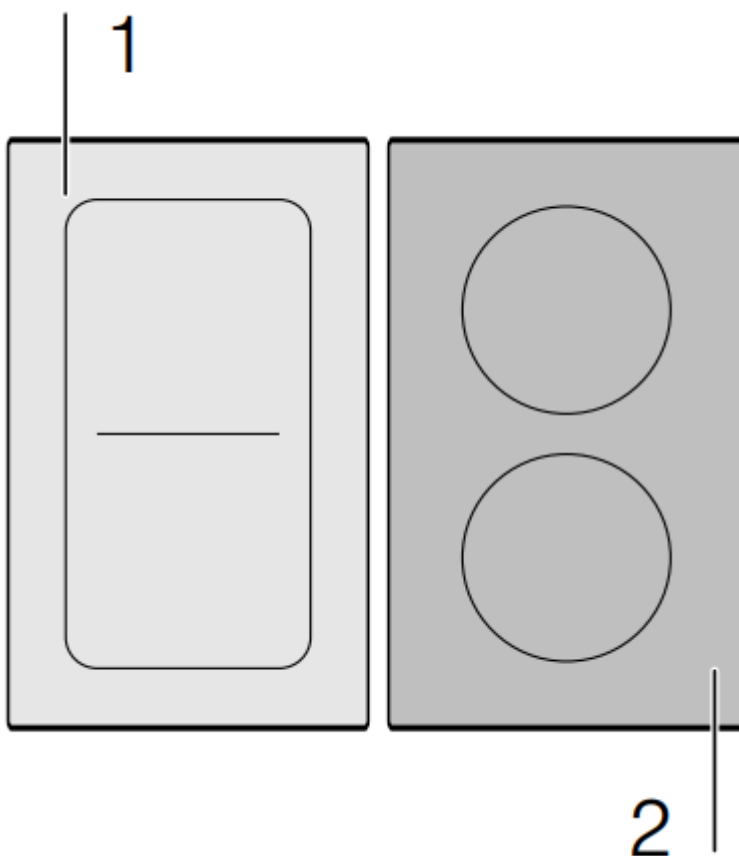

Note: The SpeedBoost® function can also be activated in the FlexInduction® area if it is being used as a single cooking zone.

Activating

1. Select a element.
2. Touch the Speed Boost key. The > indicator lights up.

The function is activated.

Deactivating

1. Select a element.
2. Touch the Speed Boost key. The > display goes out and the element switches back to heat setting Š.

The function is deactivated.

Note: In certain circumstances, the SpeedBoost® function can switch itself off automatically in order to protect the electronic elements inside the cooktop.

ShortBoost function

The ShortBoost function enables you to heat cookware faster than when using heat setting Š. After deactivating the function, select the appropriate heat setting for your food. This function can always be activated for an element, provided the other element in the same group is not in use (see illustration).

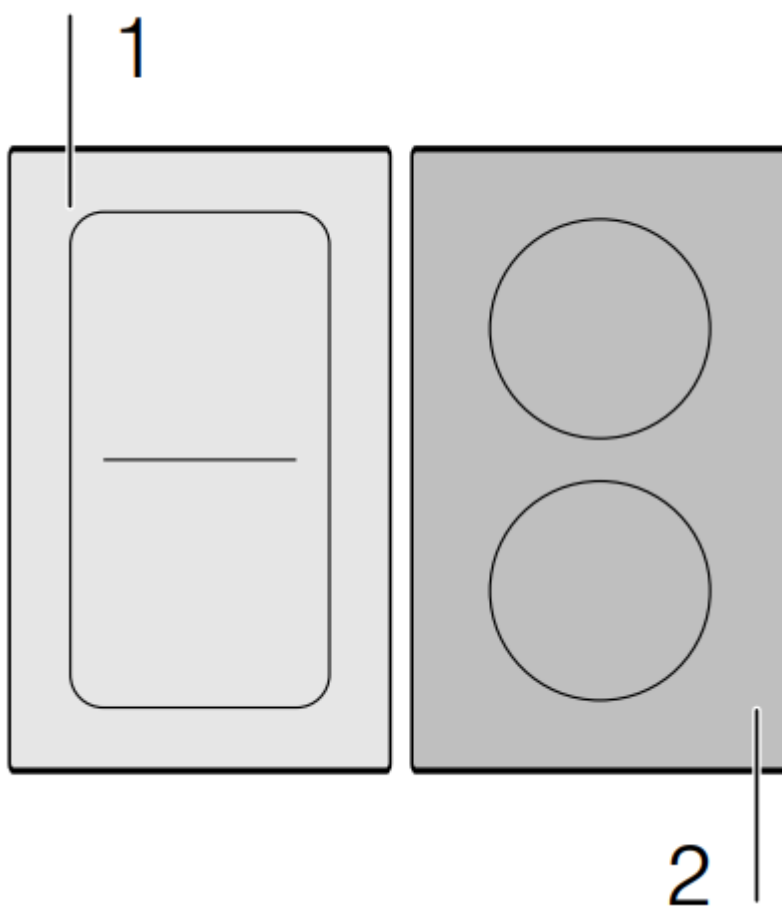

Note: The ShortBoost function can also be activated in the FlexInduction® area if it is being used as a single cooking zone.

Recommendations for use

- Always use cookware that has not been pre-heated.
- Use pots and pans with a flat base. Do not use containers with a thin base.
- Never leave empty cookware, oil, butter or lard to heat up unattended.
- Do not place a lid on the cookware.
- Place the cookware on the center of the element. Ensure that the diameter of the base of the cookware corresponds to the size of the element.
- You can find information on the type, size and positioning of the cookware in section Cooking with Induction.

Activating

1. Select an element.
2. Touch the Speed Boost key twice. The $\sim \dot{U}$ indicator lights up.

The function is activated.

Deactivating

1. Select an element.
2. Touch the Speed Boost key. The $\sim \dot{U}$ display goes out and the element switches back to heat setting \dot{S} .

The function is deactivated.

Note: In certain circumstances, the ShortBoost function can switch itself off automatically to protect the electronic elements inside the cooktop.

Keep Warm function

This function is suitable for melting chocolate or butter and for keeping food warm.

Activating

1. Select the required power level.
2. Within the next 10 seconds, touch the Keep Warm key. The $-\odot$ indicator lights up.

The function is activated.

Deactivating

1. Select an element.
2. Touch the Keep Warm key. The $-\odot$ display goes out. The element switches itself off and the residual heat indicator appears.

The function is deactivated.

Panel Lock

You can use the panel lock to prevent the appliance from being turned on accidentally.

Activating and deactivating the panel lock

The cooktop must be turned off.

To activate:

1. Switch on the cooktop using the main switch.
2. Touch the Panel Lock key for approx. 4 seconds. The D indicator lights up for 10 seconds.

The cooktop is locked.

To deactivate:

1. Switch on the cooktop using the main switch.
2. Touch the Panel Lock key for approx. 4 seconds.

The lock is released.

Automatic panel lock

With this function, the panel lock is automatically activated whenever you turn off the cooktop.

Turning on and off

See "Basic settings" section.

Wipe protection

Cleaning the control panel while the cooktop is on may change the settings. In order to avoid this the cooktop has a wipe protection function.

To activate: Touch the Panel Lock key. An acoustic signal sounds. The control panel is locked for 35 seconds. You can now wipe over the surface of the control panel without altering any settings.

To deactivate: The control panel will be unlocked once 35 seconds have elapsed. To release the function early, touch the Panel Lock key.

Notes

- An audible signal sounds 30 seconds after activation. This indicates that the function is about to finish.
- The wipe protection function does not lock the main switch. The cooktop can be switched off at any time.

Automatic time limitation

If the element is used for prolonged periods of time without changes in the settings being made, the automatic time limitation function is triggered. The element stops heating. "E" and the residual heat indicator "H" flash alternately in the display. The indicator goes out when any symbol is

pressed. The element can now be reset. When the automatic time limitation is activated depends on the selected heat level (from 1 to 10 hours).

Basic settings

The appliance has various basic settings. You can adjust these settings to the way you usually cook.

Display	Function
	Automatic panel lock
	0 Manual*. 1 Automatic.
c 1	2 Function deactivated.
	Signal tones
	0 Confirmation and error signals are switched off. 1 Only the error signal is switched on. 2 Only the confirmation signal is switched on.
c 2	3 All signal tones are switched on.*
	Display energy consumption
c 3	0 Switched off.* 1 Switched on
* Factory settings	
Display	Function
	Automatically setting the cooking time
	00 Switched off.*
c 5	0 1:59 Time until automatic switch-off.
	Audible signal duration for the timer function
	1 10 seconds.* 2 30 seconds.
c 6	3 1 minute.
	Power management function. Limiting the total power of the cooktop
	0 Switched off.* 1 1000 W minimum power. 1. 1500 W 2 2000 W ...
c 7	9 Maximum power of the cooktop.
	Changing the preset heat settings for the PowerMove function
	_9 Preset heat setting for the front cooking zone. -5 Preset heat setting for the central cooking zone.
c 11	- 1 Preset heat setting for the rear cooking zone.
c 12	Checking cookware, result of the cooking process
	0 Not suitable 1 Not perfect 2 Suitable
c 13	Configure the flexible cooking zone activation.
	0 As two independent elements.* 1 As a single element.
	Restoring the factory settings
	0 Individual settings.* 1 Restore factory settings.
c 0	
* Factory settings	

Changing the basic settings

The cooktop must be turned off.

1. Turn on the cooktop with the main switch.
2. Within 10 seconds, touch the Kitchen Timer key for about 4 seconds.

The first four displays provide product information. Touch the settings area to view the individual displays.

Product information	Display
Directory for the technical after-sales service (TK)	01
FD number	Fd
FD number 1	95.
FD number 2	0.5

3. Touching the Kitchen Timer key again takes you to the basic settings. TM, lights up in the timer display and < light up in the displays.

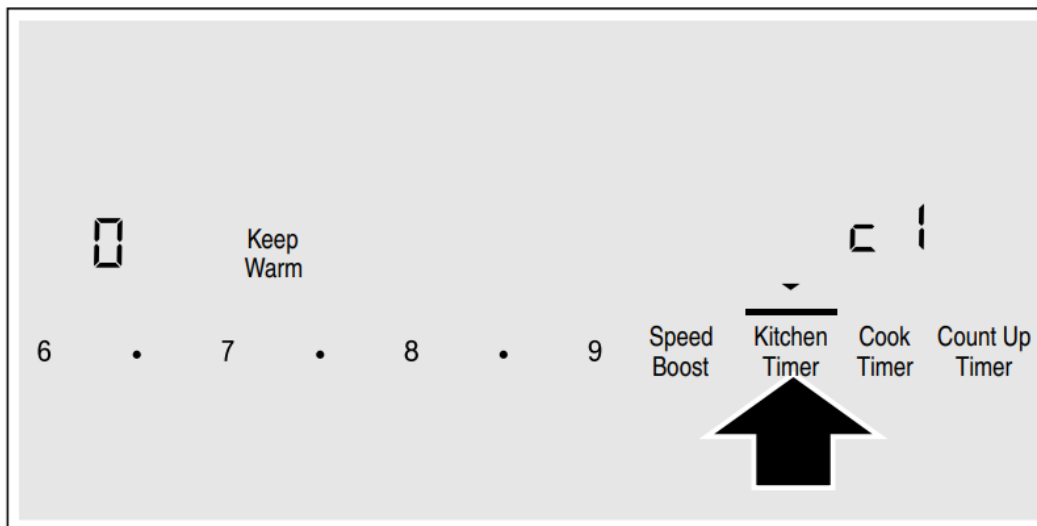

4. Touch the Kitchen Timer key repeatedly until the indicator for the required function is displayed.
5. Set the required value with the number keys.

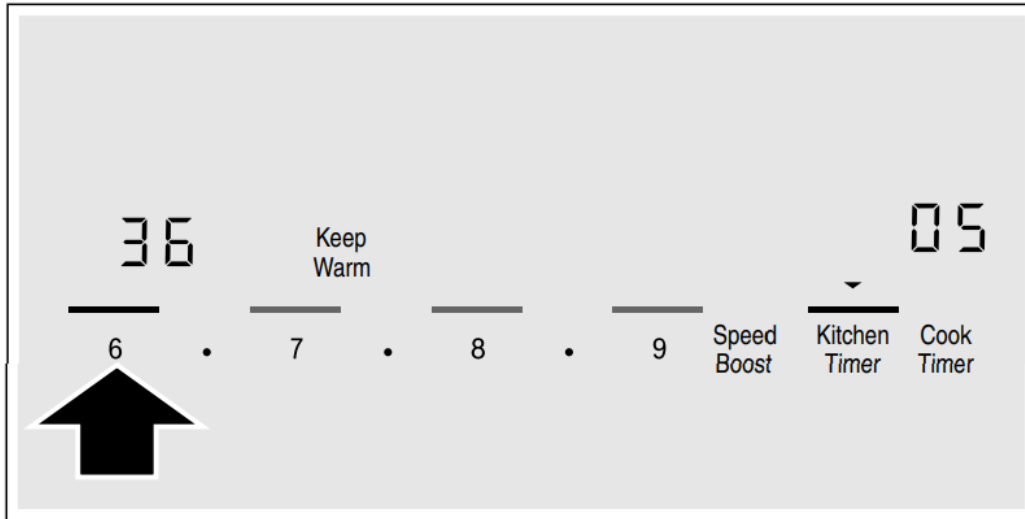

6. Touch the Kitchen Timer key again for at least 4 seconds. The settings have been stored.

Quit basic settings

Turn the cooktop off with the main switch.

Energy consumption indicator

This function indicates the total amount of energy consumed by this cooktop the last time it was used for cooking. Once switched off, the energy consumption in kWh is displayed for 10 seconds. The picture shows an example with an energy consumption of 1.08 kWh.

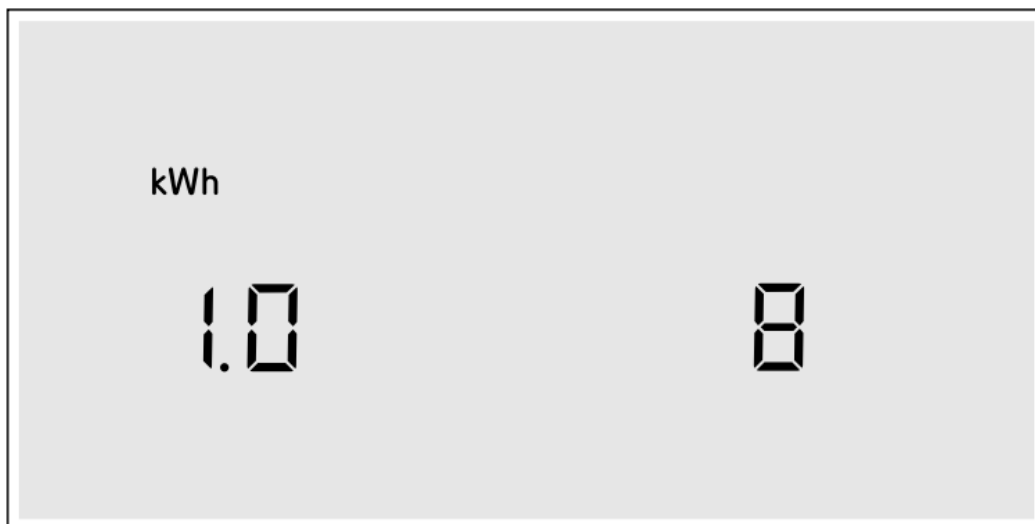

You can find out how to turn this function on in the section on ~ "Basic settings".

Cooking with Induction

Advantages of induction cooking

Induction cooking is very different from traditional cooking methods, as heat builds up directly in the item of cookware. This offers numerous advantages:

- Saves time and energy when boiling and frying.
- Easier to care for and clean. Spilled food does not burn on as quickly.
- Heat control and safety – the cooktop increases or decreases the heat supply as soon as the user changes the setting. The induction element stops the heat supply as soon as the cookware is removed from the element, without having to switch it off first.

Cookware

Only use ferromagnetic cookware for induction cooking, such as:

- Cookware made from enameled steel or cast iron
- Special induction-compatible cookware made from stainless steel.

To check whether your cookware is suitable for induction cooking, refer to the section on ~ "Suitability test of cookware".

To achieve a good cooking result, the ferromagnetic area on the base of the pan should match the size of the element. If an element does not detect an item of cookware, try placing it on another element with a smaller diameter.

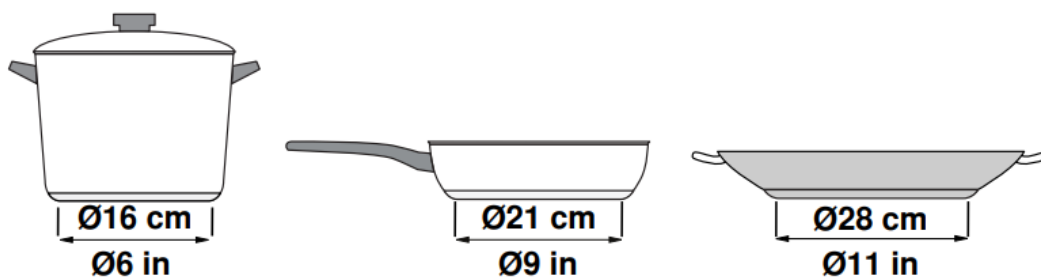

Some induction cookware does not have a fully ferromagnetic base:

- If the base of the cookware is only partially ferromagnetic, only the area that is ferromagnetic will heat up. This may mean that heat will not be distributed evenly. The non-ferromagnetic area may not heat up to a sufficient temperature for cooking.

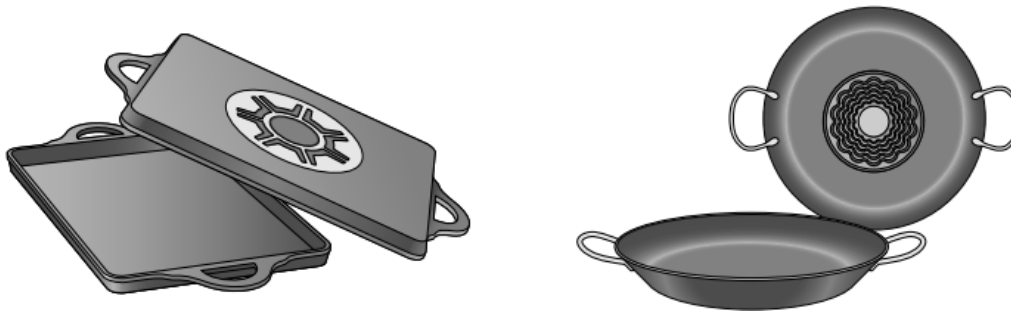

- The ferromagnetic area will also be reduced if the material of which the base of the cookware is made contains aluminum, for example. This may mean the cookware will not become sufficiently hot or detected.

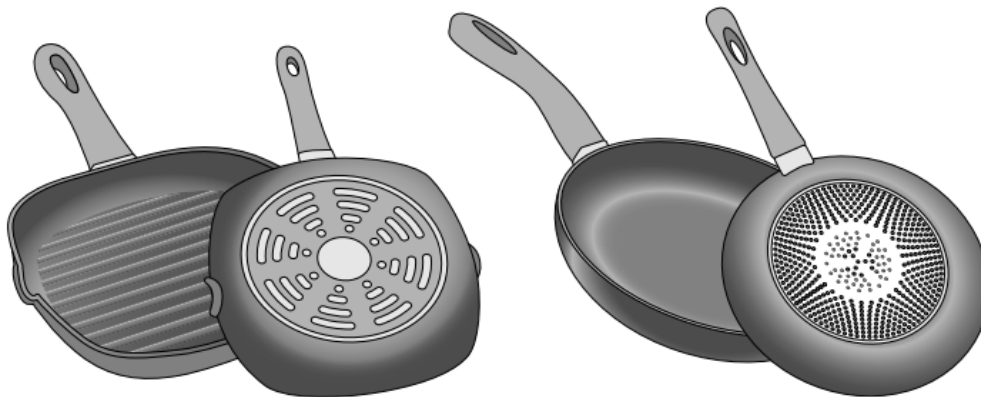

Unsuitable cookware

Do not ever use adapter plates for induction or cookware made of:

- Traditional Stainless Steel, Copper, Aluminum
- Glass
- Clay

Properties of the base of the cookware

The material(s) of which the base of the cookware is made can affect the cooking result. Using pots and pans made from materials that distribute heat evenly through them, such as stainless-steel pans with a three-layer base, saves time and energy.

Use cookware with a flat base; if the base of the cookware is uneven, this may impair the heat supply.

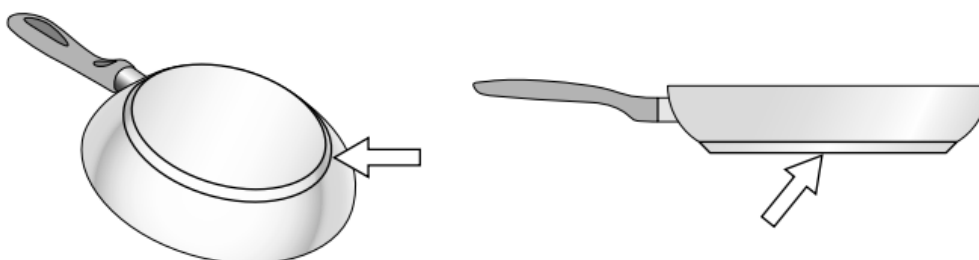

No pan or improper size

If no pan is placed on the selected element, or if it is made of unsuitable material or is not the correct size, the power level displayed on the element indicator will flash. Place a suitable pan on the element to stop the flashing. If you take longer than 90 seconds to place a suitable pan on the element, it will automatically turn off.

Empty pans or pans with a thin base

Do not heat up empty pans, or use pans with a thin base. The cooktop is equipped with an internal safety system. However, an empty pan may heat up so quickly that the "automatic switch off" function may not have time to react and the pan may reach very high temperatures. The pan base could melt and damage the cooktop glass. In this case, do not touch the pan and switch the cooktop off. If the cooktop fails to work after it has cooled down, please contact the technical service.

Pan detection

Each element has a lower limit for pan detection. This depends on the diameter of the ferromagnetic area of the cookware and the material of which its base is made. For this reason, you should always use the element that best matches the diameter of the base of the pan.

Cleaning and Maintenance-Cooktop

Daily Cleaning

Notes

- Clean only parts listed in manual.
- Bosch cleaners have been tested and approved for use on Bosch appliances. Other recommended cleaners do not constitute an endorsement of a specific brand.

Cleaning the Cooktop

WARNING

DO NOT TOUCH SURFACE UNITS OR AREAS NEAR UNITS Surface units may be hot even though they are dark in color. Areas near surface units may become hot enough to cause burns. During and after use, do not touch, or let clothing or other flammable materials contact surface units or areas near units until they have had sufficient time to cool. Among those areas are the cooktop and surfaces facing the cooktop.

CAUTION

Do not use any kind of cleaner on the glass while the surface is hot. The resulting fumes can be hazardous to your health. Heating the cleaner can chemically attack and damage the surface.

Precautions for Long Life and Good Appearance of the Surface

- Regular, daily care using the glass ceramic cooktop cleaner will protect the surface and make it easier to remove food soil and water spots.
- The glass ceramic cooking surface is a durable material resistant to impact but not unbreakable if a pan or other object is dropped on it.
- Never cook food directly on the glass.
- Avoid placing a wok support ring, trivet or other metal stand on glass surface.
- Do not use the glass surface as a cutting board.
- Do not slide cookware across the cooking surface as it may scratch the surface.
- Do not place wet pans on the glass surface.

Care Before Use

Care is easy when preventative steps are taken. For example, apply a small amount of glass ceramic cooktop cleaner (packaged with range) on a daily basis. This provides a protective film that makes it easy to remove water spots or food spatters. The temperature of the cooking surface reduces the protective qualities of this cleaner. It must be reapplied before each use. Use a clean cloth and apply glass ceramic cooktop cleaner before each use to remove dust or metal marks that can occur on the counter level surface between uses.

Daily Cleaning Techniques

WARNING

RISK OF BURNS

Be extremely careful as the cooking surface is hot. If using damp sponge or cloth, wait until the cooktop has cooled sufficiently to prevent steam burns. Also, some cleaners give off noxious fumes when applied to hot surfaces.

1. Clean the surface when it is completely cool with glass ceramic cooktop cleaner.
Exception: Remove dry sugar, sugar syrup, tomato products and milk with the razor blade scraper once the cooktop has sufficiently cooled. See Cooktop Care Chart on the next page.
2. Wipe off spatters with a clean, damp sponge or a paper towel. Rinse and dry. Use white vinegar if smudge remains; rinse.
3. Apply a small amount of the glass ceramic cooktop cleaner. When dry, buff surface with a clean paper towel or cloth.

Using the Razor Blade Scraper

Use the scraper to remove dried or baked on foods. Wait until the cooktop has cooled sufficiently. Hold the scraper at a 30° angle. Move it over the soil to lift it off of the cooktop. Finish with a clean, damp sponge or paper towel. Apply white vinegar if smudge remains and rinse.

WARNING

RISK OF INJURY

The blade is extremely sharp. Risk of cuts. Protect the blade when not in use. Replace the blade immediately when any imperfections are found. Follow manufacturer's instructions.

Cleaning guidelines

When using a cleaner, use only a small amount; apply to a clean paper towel or cloth. Wipe on the surface and buff with a clean dry towel. For best results, use a glass cooktop cleaner such as the Bosch Glass Cooktop Cleaner (part number 12010030), which can be ordered online at www.bosch-home.com/us/store (for U.S. customers only). Other cleaners include Bon Ami®, Soft Scrub® (without bleach), and white vinegar.

Avoid these cleaners

- Glass cleaners which contain ammonia or chlorine bleach. These ingredients may damage or permanently stain the cooktop.
- Caustic cleaners such as Easy Off® may stain the cooktop surface.
- Abrasive cleaners.
- Metal scouring pads and scrub sponges such as Scotch Brite® can scratch and/or leave metal marks.
- Soap-filled scouring pads such as SOS® can scratch the surface.
- Powdery cleaners containing chlorine bleach can permanently stain the cooktop.
- Flammable cleaners such as lighter fluid or WD-40.

Type of Soil	Possible Solution
<p>Dry sugar, sugar syrup, milk or tomato spills. Melted plastic film or foil. All these items require removal after the cooktop has sufficiently cooled. Be extremely careful as the cooking surface is hot. Failure to remove these can permanently damage the surface.</p>	<p>Remove these types of spills after the surface has sufficiently cooled using the razor blade scraper. Use a new, sharp razor in the scraper. Remove pan and turn off the element. Wearing an oven mitt, hold scraper at 30° angle, using care not to gouge or scratch the glass. Push soil off the heated area. After the surface has cooled, remove the residue and apply the glass ceramic cooktop cleaner.</p> <p>WARNING</p> <p>RISK OF INJURY</p> <p>The blade is extremely sharp. Risk of cuts. Protect the blade when not in use. Replace the blade immediately when any imperfections are found. Follow manufacturer's instructions.</p>
<p>Burned-on food soil, dark streaks, and specks</p>	<p>Soften by laying a damp paper towel or sponge on top of soil for 30 minutes. Use a plastic scrubber and glass ceramic cooktop cleaner or use the razor blade scraper. Rinse and dry.</p>
<p>Greasy spatters</p>	<p>Use a soapy sponge or cloth to remove grease; rinse thoroughly and dry. Apply glass ceramic cooktop cleaner.</p>
<p>Metal marks: Iridescent stain</p>	<p>Pans with aluminum, copper or stainless steel bases may leave marks. Treat immediately after surface has cooled with glass ceramic cooktop cleaner. If this does not remove the marks, try a mild abrasive (Bon Ami®, Soft Scrub® without bleach) with a damp paper towel. Rinse and reapply glass ceramic cooktop cleaner. Failure to remove metal marks before the next heating makes removal very difficult.</p>
<p>Hard water spots: Hot cooking liquids dripped on surface</p>	<p>Minerals in some water can be transferred onto the surface and cause stains. Use undiluted white vinegar, rinse and dry. Recondition with glass ceramic cooktop cleaner. Remove boilovers and stains before using the cooktop again.</p>
<p>Surface scratches:</p>	



Small scratches are common and do not affect cooking. They become smoother and less noticeable with daily use of the glass ceramic cooktop cleaner.

Apply glass ceramic cooktop cleaner before using to remove sand-like grains and grit such as salt and seasoning. Scratches can be reduced by using pans with bases that are smooth, clean, and dry before use. Use recommended glass ceramic cooktop cleaner daily.

NOTE: Diamond rings may scratch the surface

Operation-Oven

Oven Control Panel

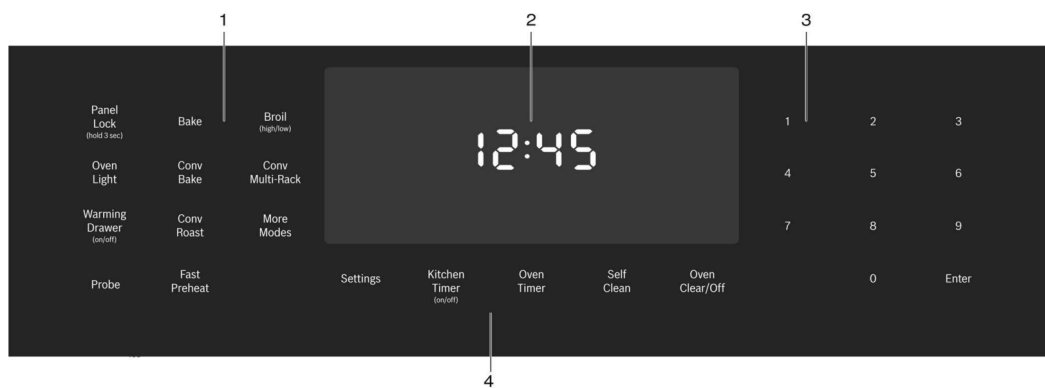

800 Series Oven Control Panel

- | | |
|---|--------------------------|
| 1 | Mode Selection Buttons |
| 2 | Display |
| 3 | Numeric Keypad Buttons |
| 4 | Special Function Buttons |

Note: You only need to press lightly on the buttons to operate them.

Button Descriptions

Panel Lock
(hold 3 sec) Turns Panel Lock mode on and off.

Oven Light Turns the oven lights on or off.

Kitchen Timer
(on/off) Starts and stops the kitchen timer(s). Press to edit a timer.

Oven Timer Press to edit the oven timer for the selected oven. Turns off the oven at the end of the specified time.

Settings Provides access to user settings to allow customization of basic display, language and other features. Use also to set clock.

Probe Sets probe target temperature. Probe allows monitoring of internal meat temperature during cooking.

**Fast
Preheat**

Enables Fast Preheat option.

**Self
Clean**

Activates Self Clean mode.

**Warming
Drawer
(on/off)**

Turns the warming drawer on or off.

**More
Modes**

Allows access to cooking/heating modes that do not have a direct access button.

More Modes

Additional modes are available by pressing the More Modes button. These modes include Convection Broil, Warm, Pizza, Proof and Roast. These are discussed in the Getting the Most Out of Your Appliance section later in this manual.

Display Symbols



Door Lock- Is displayed when the oven door is locked.



Fast Preheat Symbol- Is displayed when Fast Preheat is active.



Probe Symbol- Appears when a probe is detected.



Panel Lock- Is displayed when the control panel is locked.



Self Clean- Is displayed when Self Clean is active.

About the Oven

Your new oven combines premium cooking results and simple operation. The oven design has been optimized to improve heat distribution in the oven cavity. The result is even browning, shorter cooking times and lower energy consumption.

Thanks to the Self Clean mode, hours of scrubbing into the darkest corners of the oven is a thing of the past. The oven burns off soil simply and easily. All that is left to do is to remove a few ashes from the oven when Self Clean is done and the oven is cool enough to touch.

Clear labeling of the touch pads makes operating the oven very easy. This manual includes all instructions for operating the oven.

Please call us if you ever have any questions. Our telephone number is located at the beginning of this manual. We welcome your comments and suggestions.

Basic Features

Setting the Clock

The oven includes time functions that require the current time to be set. It is therefore important to set the clock before beginning to use the oven. The oven cannot be in a cooking mode to access the clock set mode.

To set the clock:

1. The oven must be in Standby mode (oven is powered on, but no cooking mode or timer in operation).
2. To access the clock set mode: Press the Settings button. The display shows “SET CLOCK”. Press Enter to edit the clock.
3. Use the numeric keypad to enter the desired time. Each number pressed is entered at the right and moving previously entered digits to the left. To set “12:45 pm”, press 1,2,4,5.
4. When the desired time is entered, set the time by pressing Enter. The clock is now set and running.

Setting the Cooking Mode and Temperature

There are two alternate methods to set cooking mode and temperature.

To set the Cooking Mode first, then the temperature:

1. Press the desired Cooking Mode button. The cooking mode and default temperature are displayed. The temperature flashes to show it can be edited.

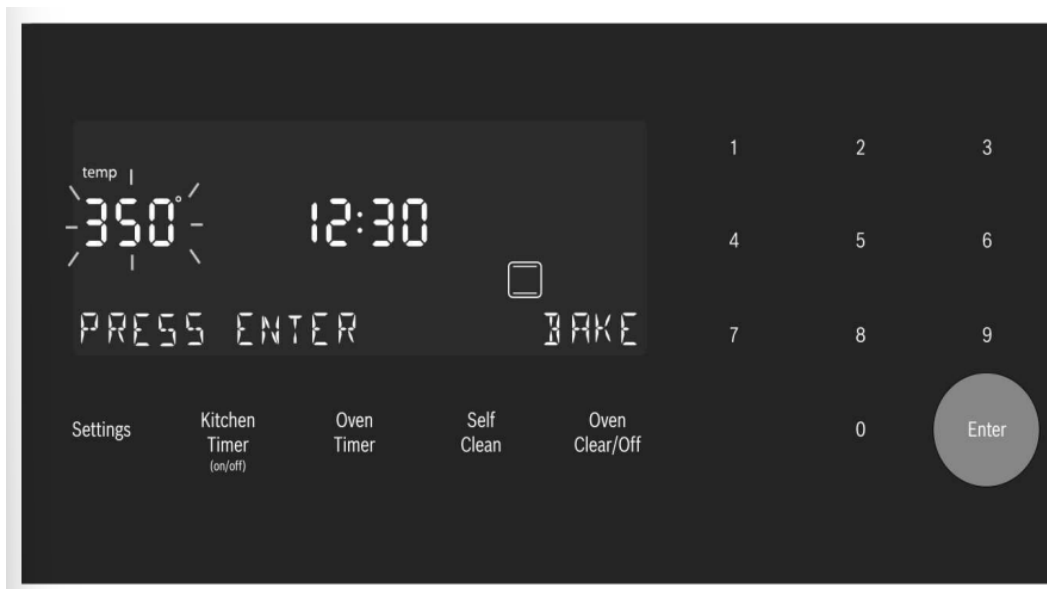

2. Press Enter to start the mode using the default temperature.
3. To change the temperature, enter the new temperature using the numeric buttons. For example, changing temperature to 375°. Press Enter to set the updated temperature.

Note: The new temperature is automatically set after 10 seconds if Enter is not pressed.



4. Preheating starts.

Note: If a temperature is entered that is not within the allowed range for the mode, an error tone will sound and the lower part of the screen will display "TEMP NOT ALLOWED".

To set the Temperature first and then the Cooking Mode (not for Broil or Convection Broil):

1. Press the numeric keys to enter the desired temperature setting. The temperature entered is displayed beside the current time.
2. Select a cooking mode that is compatible with the temperature entered. If no cooking mode is selected within 5 seconds of setting the temperature, an error tone sounds and a "SELECT MODE" message is displayed and blinks.



3. Press a Mode Selection button to select a cooking mode.

The new mode and temperature set automatically after 10 seconds if Enter is not pressed.

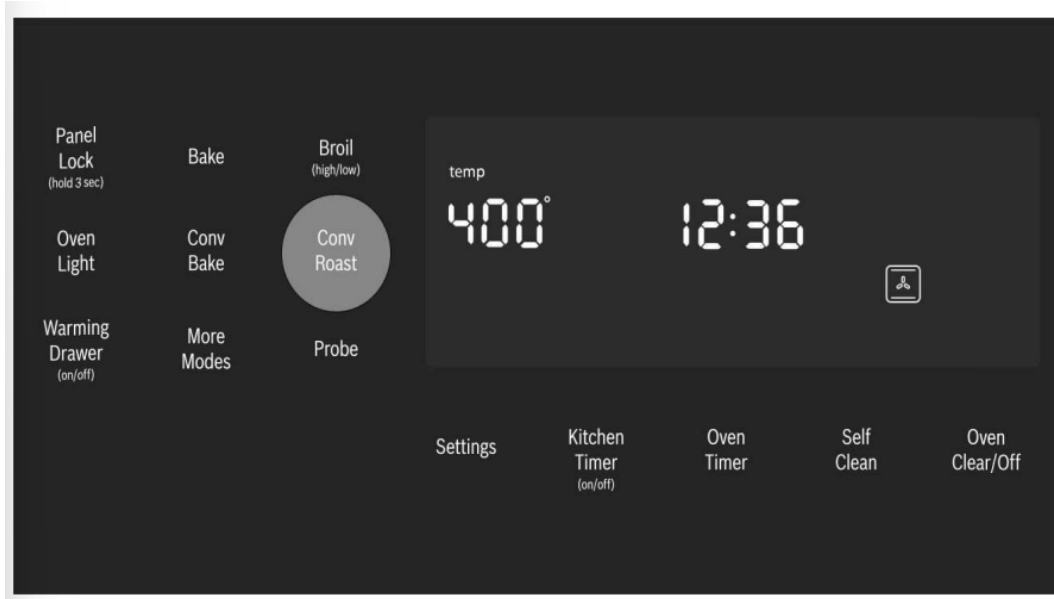

Note: If a temperature is entered that is not within the allowed range for the mode selected, an error tone will sound and the lower part of the screen will display “TEMP NOT ALLOWED”.

To change the Oven Temperature:

1. Press the Cooking Mode button.
2. The current temperature flashes. Use the numeric buttons to enter a new temperature. Press Enter.

Heating Time Limitation

The maximum heating time is limited. If you forget to turn off the oven, it turns off automatically after a set period of time. The maximum time for Sabbath Mode is 74 hours. For all other cooking modes the maximum allowed time is 24 hours.

Temperature in °F	Temperature in °C	Max. Time Allowed without Activity
100-200	30-120	24 hours
201-550	121-300	12 hours

Timer

Your new oven is equipped with two types of timers.

Kitchen Timer- is a countdown timer that has no affect on oven heating. The kitchen timer is used for general kitchen timing needs.



Oven Timer- is a countdown timer which upon reaching 00:00 turns the oven off, stopping the current mode. The oven timer is used to set how long a mode will run. Not available for Broil, Convection Broil or Proof.

To set a kitchen timer (for general kitchen timer needs):

1. Press the Kitchen Timer On/Off button. 0:00 is displayed and blinks in the display. Enter the desired timer value in H/MM format using the numeric keypad.

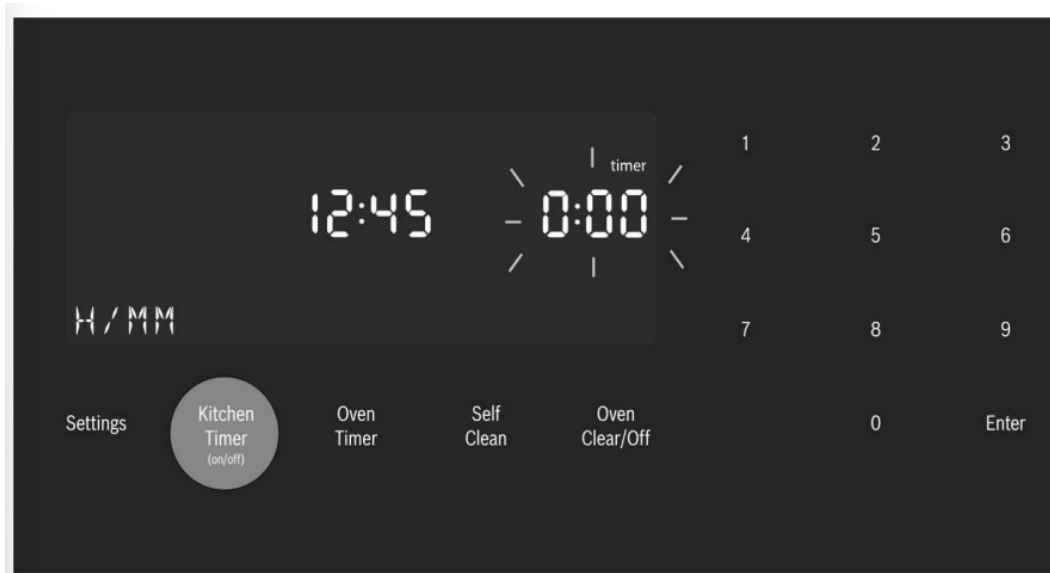

2. Press Enter. The kitchen timer starts.

3. When the kitchen timer has counted down to zero an alarm tone sounds every 10 seconds for 2 minutes and the message "TIMER END" is displayed.

Cancel the kitchen timer- press the Kitchen Timer On/ Off button.

Note: The timer does not change when other settings are changed.

To edit a kitchen timer (for setting a timer to turn the oven off):

1. Press the Kitchen Timer On/Off button.
2. The current time value blinks and can be edited.

To set an oven timer:

Note: An oven timer cannot be run during Self Clean.

1. Press Oven Timer button.
2. Select mode, press Enter. 0:00 is displayed and blinks in the display. Enter the desired timer value in H/MM format using the numeric keypad.



Press the Enter button. The oven timer counts down to 0:00.

3. When the timer reaches :00 the cooking mode ends and the message “OVEN TIMER FINISHED” is displayed. The oven alarm tone sounds every 10 seconds for 2 minutes.

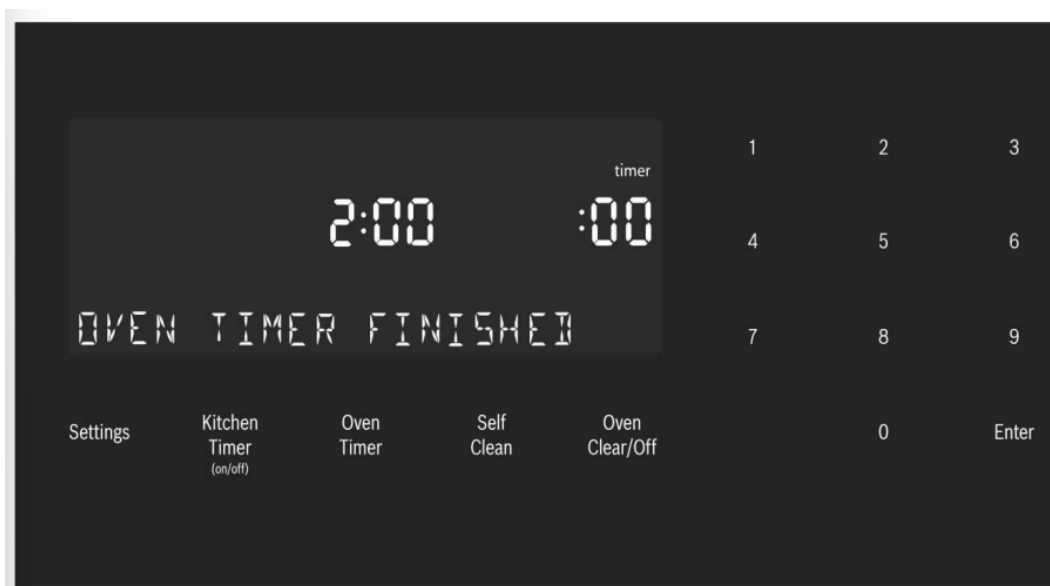

Editing the oven timer:

1. If the oven timer is running and the time remaining needs to be changed, enter the oven timer mode by pressing the Oven Timer button
2. The temperature blinks, indicating it can be edited. Input a new temperature or press Enter for no change.
3. The timer value blinks, indicating it can be edited. Input the new time and restart the timer by pressing the Enter button.

The oven timer may be cleared by entering 0:00.

Fast Preheat

Fast Preheat heats the oven quicker than standard preheat. It is available for Bake, Convection Multi Rack, Convection Bake, Convection Roast, Roast and Pizza.

Roast is found in the “More Modes” menu. If Fast Preheat is not allowed for the selected cooking mode an error tone sounds. Fast Preheat is not available for Broil, Convection Broil, Proof or Warm.

To set Fast Preheat:

1. Press Fast Preheat. The fast preheat icon appears in the display just above the mode name.
2. Press Start. Fast Preheat can be turned off by pressing Fast Preheat again.

Special Features

The special features provide you with additional conveniences when cooking. Learn more about these special features in the following sections:

Probe (some models)

Sabbath Mode

Panel Lock

Probe

The probe measures the internal temperature of the food. The probe is available for Bake, Roast and all convection cooking modes except Convection Broil.

Some models include a temperature probe used to sense internal temperature of meats during cooking.

The probe ships with a black plastic safety cap over the pointed metal end of the probe. The cap must be removed prior to use.



Inserting the probe:

Insert the tip of the probe in the middle and thickest part of the meat or the breast for poultry. Make sure the probe is not touching fat, bone or parts of the oven or the pan.

Note: Food must be completely thawed before inserting the probe into the meat.

To use the probe:

1. Insert the probe into the meat as described above. The probe symbol is displayed.
2. Connect the probe to the oven. If the probe is not connected to the oven prior to starting Probe mode, an error tone sounds and the message "INSERT PROBE" is displayed.
3. Set the cooking mode and temperature.
4. The Set Probe Temp screen is displayed. A three digit input prompt "- - -" blinks in the lower right corner. Use the numeric keypad to enter the desire probe temperature and press Enter.

Note: The minimum probe temperature that can be set is 100°F (40°C) and the maximum is 200°F (100°C). If the probe temperature entered is outside this range, an error is displayed.

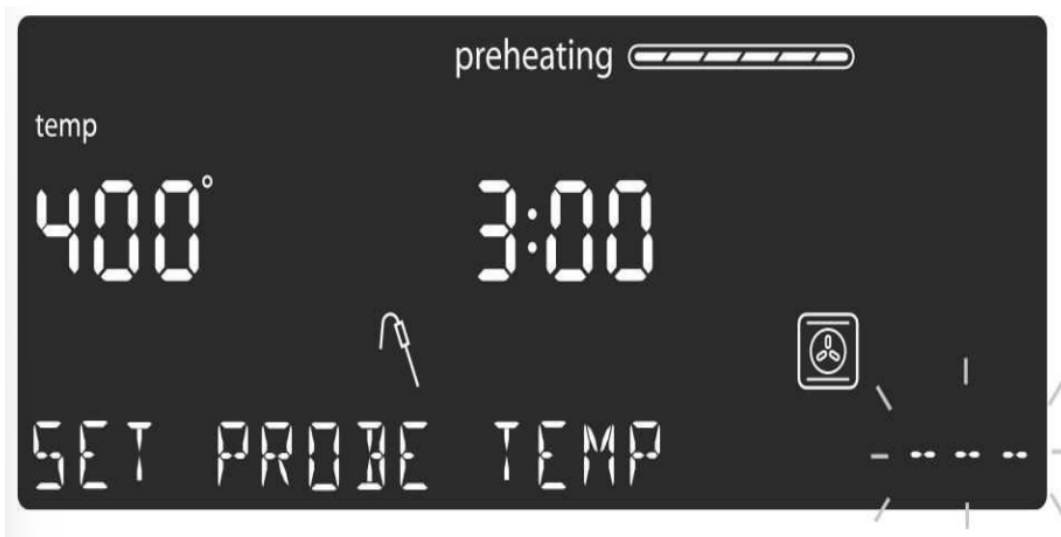

5. The probe current temperature and target temperature are both displayed in the format "105/180" at the lower right corner of the display. The actual temperature will display <80 until the food temperature reaches 80°F.

The displayed probe temperature is updated in increments of 5° during the cooking process.



6. When the probe temperature reaches the set temperature, the cooking mode turns off. The current time is displayed and the message "COOKING COMPLETE" blinks at the bottom left of the display. An alarm tone sounds every 10 seconds for 2 minutes.



This screen remains in the display until it is cleared by pressing the Oven Clear/Off button or until the probe is removed. The display then goes back to Standby mode.

Notes

- Probe is not available when an Oven Timer has been set.
- To change the probe temperature, press the Probe button. The display enters probe temperature editing mode and displays the message “SET PROBE TEMP”. Enter the new probe temperature and press Enter to accept the new value.
- Do not store the probe in the oven.
- Always use the handle of the probe for inserting and removing.
- Always use a potholder to remove the probe since it becomes hot.
- Since meat continues to cook after being removed from the oven, set the internal (probe) temperature 5°-10° below the desired final internal temperature except with poultry

Sabbath Mode

The Sabbath Mode enables those of particular faiths to use their ovens on the Sabbath. The Sabbath Mode can be entered in a Bake mode only. The bake temperature must be within the Sabbath Mode temperature range of 100° to 450°F.

If the oven light is on at the start of Sabbath Mode, it remains on throughout the Sabbath Mode operation. If the oven light is off at the start of Sabbath Mode, it remains off throughout the Sabbath Mode operation.

To set the Sabbath Mode:

No kitchen timers or oven timers may be running when Sabbath Mode is entered.

1. Begin a Bake operation. While Bake is running, press and hold the Oven Timer button for 5 seconds. The message: “SABBATH NOT AVAILABLE” is displayed if a timer is running or the set temperature is outside the allowable range.

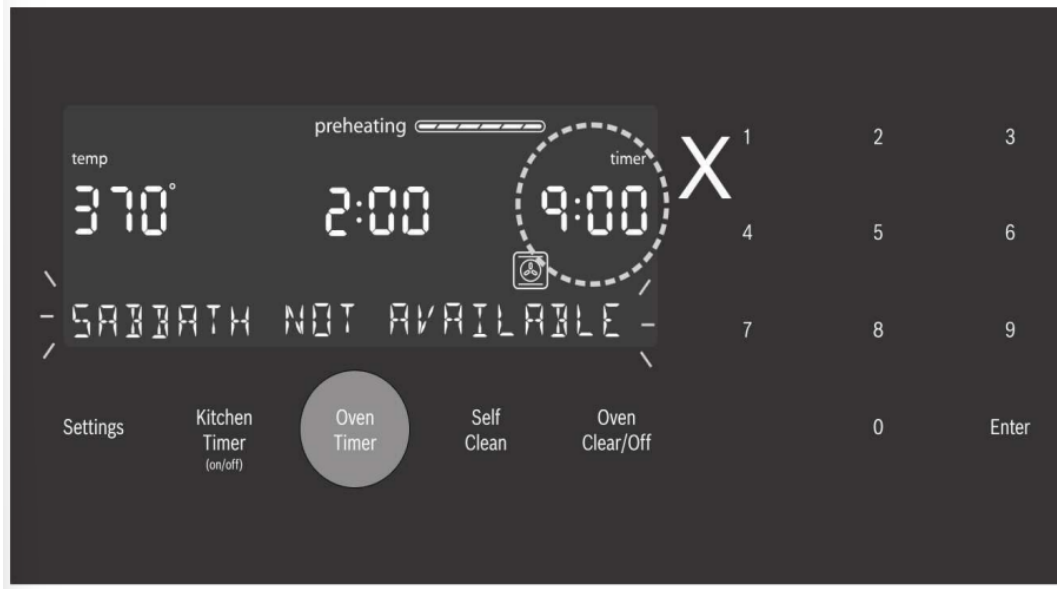

If no timers are running, the Sabbath Mode settings appear in the display. The Sabbath Mode timer blinks showing the value can be edited. The default value is 74:00 (the maximum number of hours for which Sabbath Mode can be set).



2. Press Enter to accept the default 74:00 hours and start Sabbath Mode or use the numeric keypad to enter the desired Sabbath Mode timer value. Timer values between 0:01 and 74:00 can be entered.

Note: If no changes are made within 10 seconds, Sabbath Mode auto starts.

3. Once Sabbath Mode has begun, the display changes to show the message "SABBATH ON".

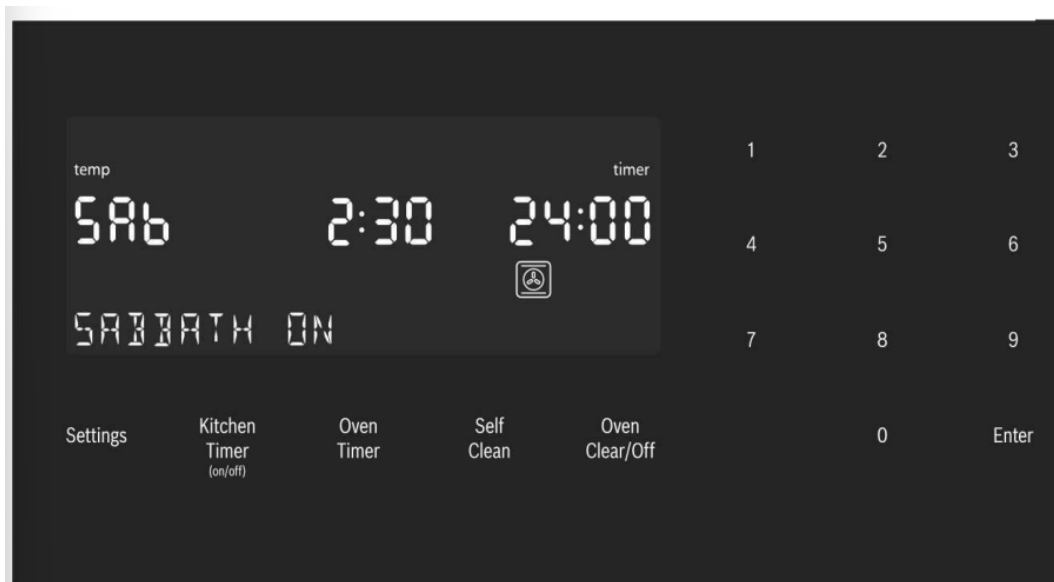

4. After the Sabbath Mode countdown reaches zero, the oven displays the current time and the message “SABBATH”. No changes can be made at this point. To end the Sabbath Mode and return to normal function, press the Oven Clear/Off button.

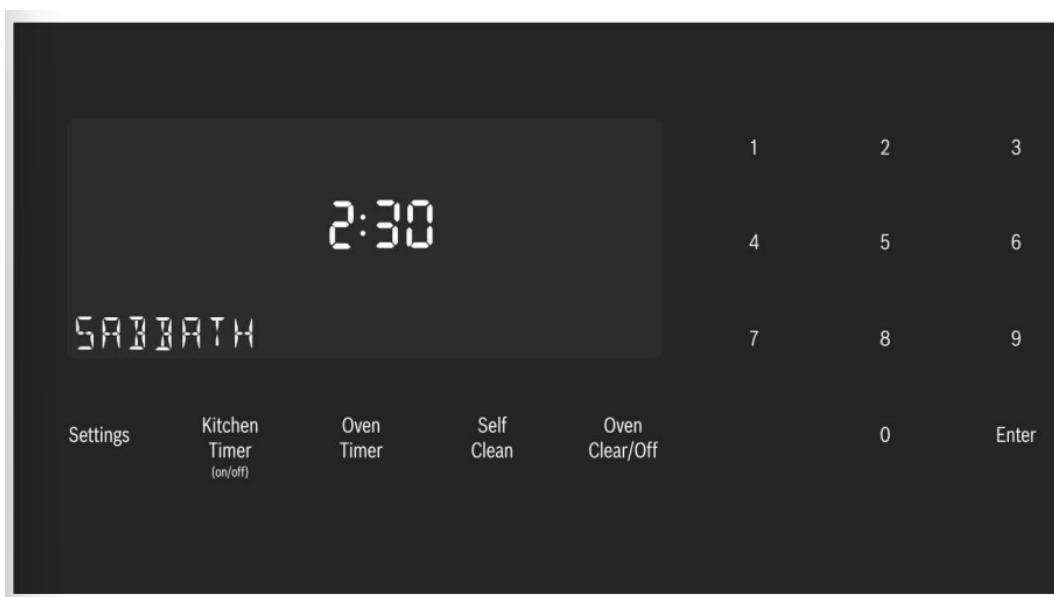

Notes

- The temperature range in Sabbath Mode is 100°F to 450°F.
- The Sabbath Mode timer can be set between 0:01 and 74:00 hours.

To edit the Sabbath Temperature:

While editing the temperature in Sabbath Mode there is no feedback from the control. If an invalid temperature is set, the oven will default back to the previous running temperature.

1. Press the Bake button.
2. Enter the new desired set temperature.

3. Press Enter. The oven will adjust its set temperature after randomized delay.

Panel Lock

Allows the user to disable all buttons on the control panel. Panel Lock can only be enabled in Standby mode.

1. To enable Panel Lock, press and hold the Panel Lock button for 3 seconds (in Standby mode).
2. To disable Panel Lock, press and hold the Panel Lock button for 3 seconds. The display returns to Standby mode.

Settings

The oven setup menu is used to customize certain oven settings.

The oven must be in Standby mode (no cooking mode or timer running) in order to access the setup menu.

To make changes to Settings menu items:

1. Press the Settings button.
2. The first setup item is displayed. The display shows "SET CLOCK". Press Settings again to access the settings menu.
3. To display a different setup item, press the number corresponding to that setting (see table following or press the Settings button to cycle through available options).
4. To change the value for the displayed setting, press the Enter button to enter the edit mode. Use the numeric keypad to change the setting value. The corresponding setting value is shown in the table following. For the temperature offset, with the item in edit mode, press "-" or "+" first, then the numeric offset value. The new value is automatically accepted as the display reverts from edit mode back to display mode.

To exit the Settings menu:

Press the Oven Clear/Off button.

Oven Temperature Offset

The oven is calibrated to provide accurate results. This feature is useful if you prefer your foods lighter or darker. When an offset temperature is selected, the actual oven temperature is raised or lowered by this value.

Do not use residential oven thermometers to evaluate oven temperatures as they will fluctuate throughout cooking.

The oven must be turned off in order to set an offset value. Refer to Temperature Offset in Settings Menu Options for setting.

Note: This process can be repeated until a satisfactory result is achieved. Each time these steps are repeated, the oven temperature sets to zero. In other words, if the offset was changed by 5°

the first time, the second time it will need to be offset by 10°. The oven will not add to the original offset.

Settings Menu Options

	Menu Item	Description	Default
1	Temperature Mode	Fahrenheit (°F) or Celsius (°C)	°F
2	Brightness	High, Medium, Low	High
3	Volume	High, Medium, Low	High
4	Clock Mode	12-hour or 24-hour display mode. 12HR, 24HR	12HR
5	Auto Convection Conversion	Decreases oven temperature by 25°F for Convection Bake and Convection Multi-Rack cooking modes. On, Off	OFF
6	Button Beep	Tone when button is pressed. ON, OFF	ON
7	Standby Clock Display	Clock displays when no cooking mode or timer is in use. ON, OFF	ON
8	Language	Language setting: English (EN), French (FR)	EN
9	Temperature Offset	Sets the temperature offset value for Bake, Convection Bake, Roast, Convection Roast and Convection Multi-Rack.	0

Note: Temperature offsets must always be entered as 2 digits.

Example: 5° is entered as 05.

When an offset value is entered, the actual oven temperature is increased or decreased by this value. This feature is useful if food is either too brown or too light.

The range for changing the offset is between +/- 35°F (+/- 19°C) in 1° increments.

The default value is 0.

Getting the Most Out of Your Appliance

General Tips

Pan Placement

Baking results are better if pans are placed in the center of the oven. If baking more than one pan on a rack, allow at least 1" to 1 1/2" of air space around the pan. When baking four cake layers at the same time, stagger pans on two racks so that one pan is not directly above the other.

Rack Position

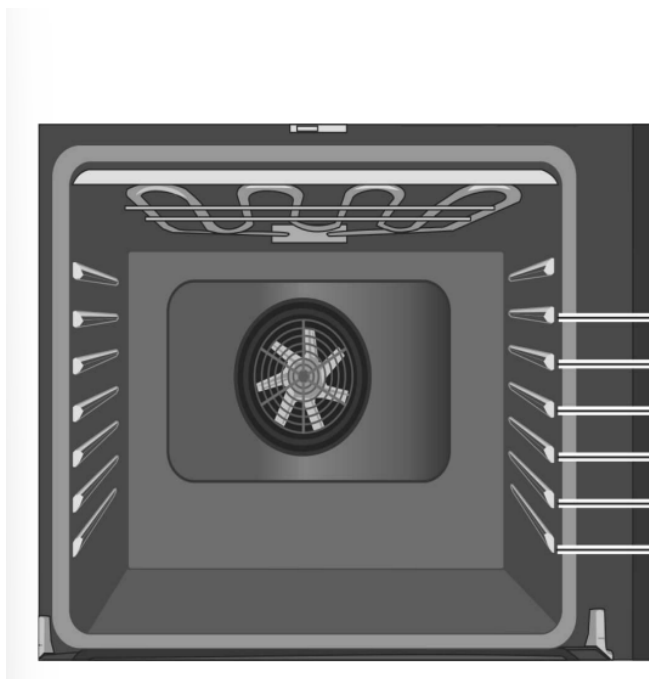

Rack positions are numbered from 1 to 6, from bottom to top.

Consult the food cooking charts at the back of this manual for recommended rack positions.

The rail at the top of the oven is used as the guide for the top rack (position 6). Use rack positions 1 through 6 only. DO NOT attempt to use the top guide to support an oven rack.

Rack Position	Best For
6 (highest usable position)	hamburgers, steaks
5	toasting bread, broiling most meats, melting cheese
4	thicker meats
3	broiling poultry, most baked goods on a cookie sheet or baking pan using a single rack, includes frozen convenience foods, cakes, casseroles, frozen pizza
2	small roasts or poultry, bundt cakes, pies, breads
1 (lowest usable position)	large roasts, turkey, angel food cake

Aluminum Foil

WARNING

Do not use aluminum foil or protective liners to line any part of the appliance, especially the oven bottom. Installing these liners may result in risk of electric shock or fire.

Preheating the Oven

- Place oven racks in desired position before heating the oven.
- Preheat the oven when using the Bake, Convection Bake, Convection Multi Rack, Pizza, Broil, Convection Broil and Warm modes.
- Preheat is not used for Roast, Convection Roast and Proof modes.
- Allow oven to preheat while preparing recipe ingredients or food items.
- Setting a higher temperature does not shorten preheat time.
- Once oven is preheated, place food in the oven as quickly as possible to minimize the loss of heat and reduction of oven temperature.
- Use Fast Preheat to speed up preheating.

Preheat Reminders

Your oven has one of the fastest preheat times in the market using a concealed bake element. The lower element is hidden under the oven bottom. It is normal that the preheat time is different than your previous oven that had an exposed element on the bottom.

- The hidden lower element is protected from food soils and spills. Wiping up excess spills is easy.
- Preheating is not necessary for meats, poultry, casseroles and some frozen foods.
- Preheat time will be longer when the electrical supply to your house is less than 240 volts.
- Increasing the oven temperature will require a longer preheat time. For example, the preheat time for 425° F is longer than the preheat time for 350° F.

When broiling, preheat the oven 3-4 minutes. Do not preheat for more than 5 minutes.

For Best Results

- Use the cooking recommendation charts as a guide. See charts at the end of the book.
- Open the door as briefly as possible to avoid temperature reduction.
- Use the interior oven light to view the food through the oven window rather than opening the door frequently.
- Use the Timer to keep track of cooking times.

Baking Pans and Dishes

- Glass baking dishes absorb heat. Some cookware manufacturers recommend reducing the temperature 25°F when using this type of dish. Follow manufacturers' recommendations.
- Preheat the oven before adding glass baking dishes.
- Use pans that provide the desired browning. For tender, light, golden brown crusts, use light, anodized or shiny metal bakeware.
- Dark, rough or dull pans (nonstick or anodized) will absorb heat and result in a browner, crisper crust. Some manufacturers recommend reducing the temperature 25°F when using this type of pan. Follow manufacturers' recommendations.
- Insulated cookie sheets or bakeware may increase the length of cooking time.
- Do not set broil pans or any other heavy object on the open oven door.
- Do not keep empty pans or pizza stones in the oven during cooking as this changes cooking performance. Store pans outside the oven.

Opening the Oven Door

Open and close the appliance door only by holding the door handle. To avoid risk of burns, do not touch any other parts of the door.

High Altitude Baking

When cooking at high altitudes, recipes and cooking times will vary.

For accurate information, write the Extension Service, Colorado State University, Fort Collins, Colorado 80521. There may be a cost for the guides. Specify which high altitude food preparation guide you prefer: general information, cakes, cookies, breads, etc.

Condensation

It is normal for certain amount of moisture to evaporate from the food during any cooking process. The amount depends on the moisture content of the food. The moisture may condense on any surface cooler than the inside of the oven, such as the control panel.

Temperature Range by Cooking Mode

Temperatures shown are in Fahrenheit.

Mode	Lowest	Highest
Bake	100	550
Roast	100	550
Broil (Low, High)	450	550
Warm	150	225
Proof	85	125
Convection Bake	100	550
Convection Multi-Rack	100	550
Convection Roast	100	550
Pizza	100	550
Convection Broil (Low, High)	450	550

Bake

Bake is cooking with dry, heated air. Both the upper and lower elements cycle to maintain the oven temperature. The Bake mode can be used to prepare a variety of food items, from pastries to casseroles. Refer to recipe or package directions for oven temperature and baking time.

Tips

- Preheat the oven if the recipe recommends it.
- Baking time will vary with the size, shape and finish of the bakeware. Dark metal pans or nonstick coatings will cook faster with darker results. Insulated bakeware will lengthen the cook time for most foods.
- For best results, bake food on a single rack with at least 1-1" space between pans or dishes and oven walls.

- Eliminate heat loss from the oven by using the window to periodically check food for doneness instead of opening the door.

Auto Convection Conversion

Convection Bake and Convection Multi-Rack modes require a 25°F reduction in temperature. Auto Convection Conversion reduces the temperature you enter automatically. Simply enter the package or recipe temperature when setting the mode. The control calculates the correct temperature and it is shown in the display.

The Auto Convection Conversion feature can be turned on to allow for automatic temperature adjustments. See “Auto Convection Conversion” in the Settings section for details.

Convection Bake

Convection Bake is similar to Bake. Heat comes from the upper and lower heating elements. The main difference in convection baking is that the heat is circulated throughout the appliance by the convection fan.

- The Convection Bake mode is well suited for cakes, bar cookies and breads to take advantage of the bottom heat, yielding a better crust on baked items.
- The benefits of Convection Bake include:
 - Slight decrease in cook time.
 - Higher volume (yeast items rise higher).

Tips

- Reduce recipe temperature by 25°F. Refer to the cooking chart at end of this manual.
- Place food in shallow, uncovered pans, such as cookie sheets without sides.
- If baking more than one pan on a rack, allow at least 1-1½" of air space around the pan.
- For cakes use rack positions 2 and 5. Stagger pans so that one is not directly above the other (see following graphic).

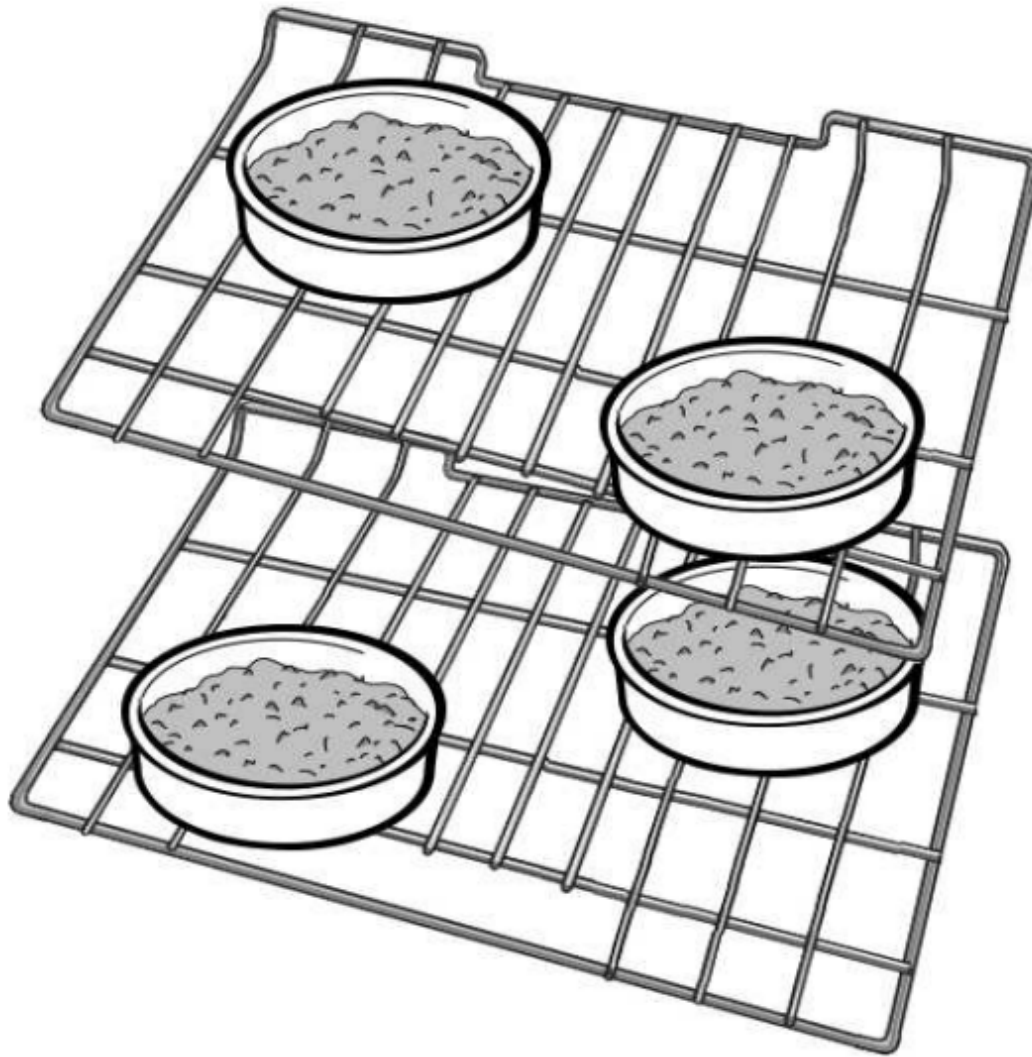

Convection Multi-Rack

Convection Multi-Rack cooks with heat from a third element behind the back wall of the oven. The heat is circulated throughout the oven by the convection fan. The Convection Multi-Rack is well suited for cooking individual serving-sized foods such as cookies and biscuits. It is also good for cooking on multiple racks (2 or 3) at the same time. Baking cookies is possible on 6 racks simultaneously. In this case, the baking time increases slightly.

The benefits of Convection Multi-Rack include:

- Even browning.
- Time savings as a result of using multiple racks at one time.

Tips

- Reduce recipe temperature by 25°F if Auto Convection Conversion is not activated.
- Place food in low-sided, uncovered pans such as cookie sheets without sides.
- If baking more than one pan on a rack, allow at least 1" to 1½" of air space around the pan. Stagger pans so that one is not directly above the other.

Pizza

In the Pizza mode, heat from the upper and lower elements is circulated throughout the oven by the convection fan.

Use the Pizza mode for fresh or frozen pizza.

Tips

- There might be a slight decrease in baking time. Check before minimum package time.
- When baking a frozen pizza: For a crispy crust, place directly on the rack. For a softer crust, use a pizza pan.
- When proofing pizza dough, coat dough with olive oil and cover it in a bowl tightly with plastic wrap to prevent crust formation.
- Sprinkle cornmeal on the pizza pan to prevent sticking.
- If using a pizza paddle, sprinkle the paddle liberally with cornmeal for ease in transferring the dough to the pan.
- If par baking handmade pizza dough, prick the dough with a fork before baking.
- If using a pizza pan, choose a dark, perforated pan for a more crisp crust and a non-perforated pan for a softer crust.
- Preheat baking stones following manufacturer's recommendations while the oven is preheating.
- Bake homemade pizzas on rack position 2 in the center of the rack.
- Follow manufacturer's directions for frozen pizza.
- The convection fan cycles on and off when using pizza mode.

Roast

Roast uses both the upper and lower elements to maintain the oven temperature. Roasting uses more intense heat from the upper element than the lower element. This results in more browning of the exterior while the inside remains especially moist.

Roast is best suited for large cuts of meat and poultry.

Tips

- Preheating the oven is not necessary.
- Use a high-sided broil pan or roasting pan. Cover dish with a lid or foil for less tender cuts of meat.
- For less tender cuts of meat, add liquids, such as water, juice, wine, bouillon or stock for flavor and moisture.
- Roasting bags and using a liquid are suitable for use in this mode.

- When roasting whole chicken or turkey, tuck wings behind back and loosely tie legs with kitchen string.

Convection Roast

Convection Roast uses heat from the top and bottom elements as well as heat circulated by the convection fan.

The Convection Roast mode is well suited for preparing tender cuts of meat and poultry. It is also suitable for roasting vegetables.

The benefits of Convection Roast mode include:

- As much as 25% faster cooking than non-convection modes.
- Rich, golden browning.

Tips

- Preheating the oven is not necessary.
- Use the same temperature as indicated in the recipe.
- Check doneness early, since roasting time may decrease.
- Do not cover meat or use cooking bags.
- Use a broil pan with a rack and grid or a shallow, uncovered pan with a rack for roasting.
- Use a meat thermometer to determine the internal temperature of the meat.
- If the meat is browned to your liking, but is not yet done, foil can be placed over the meat to prevent overbrowning.
- Let meat stand covered with foil 10-15 minutes after removing it from the oven.
- See charts for recommended rack positions.

Broil

Broil uses intense heat radiated from the upper element.

The Broil mode is best suited for cooking thin, tender cuts of meat (1" or less), poultry and fish. It can also be used to brown breads and casseroles. Always broil with the door closed.

The benefits of broiling include:

- Fast and efficient cooking.
- Cooking without the addition of fats or liquids.

Tips

- Preheat oven 3-4 minutes. Do not preheat for more than 5 minutes.
- Steaks and chops should be at least 3/4" thick.
- Brush fish and poultry with butter or oil to prevent sticking.

- Use the broil pan and grid or a deep pan with a metal rack, for broiling. Do not cover the broil grid with foil. It is designed to drain fats and oils away from the cooking surface to prevent smoking and spattering.
- Turn meats (other than fish) once during the recommended cook time. Fish does not need to be turned.
- When top browning casseroles, use only metal or glass ceramic dishes such as Corningware®.
- Never use heat-proof glass (Pyrex®); it cannot tolerate the high temperature.
- For broil times, refer to the Meat/Poultry Cooking Chart.

Convection Broil

Convection Broil is similar to Broil. It combines intense heat from the upper element with heat circulated by a convection fan.

Convection Broil mode is well suited for cooking thick, tender cuts of meat, poultry and fish. Convection Broil is not recommended for browning breads, casseroles and other foods. Always use Convection Broil with the door closed.

In addition to the benefits of standard broiling, convection broiling is faster. Temperature must be set within 450°-550°F to enable Broil and Convection Broil.

Tips

- Preheat oven 3-4 minutes. Do not preheat for more than 5 minutes.
- Steaks and chops should be at least 1" thick.
- Use the broil pan and grid or a deep pan with a metal rack, for broiling.
- Do not cover the broil grid with foil. It is designed to drain fats and oils away from the cooking surface to prevent smoking and spattering.
- Turn meats (other than fish) once during the recommended cook time. Fish does not need to be turned.
- Never use heat-proof glass (Pyrex®); it cannot tolerate the high temperature.
- For Convection Broil times, refer to the Meat/Poultry Cooking Chart.

Proof

In Proof, the appliance uses the upper and lower elements to maintain a low temperature to proof bread or other yeast doughs.

- No preheat is necessary.
- Proofing is the rising of yeast dough.
- The Proof mode temperature is 85°F to 125°F.

- The default temperature in Proof mode is 100°F.
- Loosely cover the bowl or pan and use any rack that accommodates the size of the container.
- Keep the door closed and use the oven light to check the rising of the dough.

Warm

- In Warm, the upper and lower elements maintain a low temperature in the oven cavity in order to keep food at serving temperature.
- Use the Warm mode to keep cooked foods hot for up to one hour until ready to serve. Warm mode temperatures are 150°F to 225°F.
- The default temperature in the Warm mode is 170°F.
- Foods that must be kept moist should be covered with a lid or aluminum foil.

CAUTION

WHEN USING WARM MODE, FOLLOW THESE GUIDELINES:

- Do not use the Warm mode to heat cold food.
- Be sure to maintain proper food temperature. The USDA recommends holding hot food at 140°F (60°C) or warmer.
- DO NOT warm food longer than one hour.

Cleaning and Maintenance-Oven

Cleaning the Oven

Self-Clean

WARNING

WHEN USING THE SELF-CLEAN SETTING

- During the elimination of soil during self-cleaning, small amounts of Carbon Monoxide can be created and the fiberglass insulation could give off very small amounts of formaldehyde during the first several cleaning cycles. To minimize exposure to these substances, provide good ventilation with an open window, or use a ventilation fan or hood.
- Children should not be left alone or unattended in an area where appliances are in use. During the Self Clean cycle, parts of the appliance may become potentially harmful to persons who lack adult knowledge of appliances and adult reactions to potentially harmful conditions.
- Do not block the oven vent(s) during the selfcleaning cycle. Always operate the unit according to the instructions in this manual.

- When self-cleaning, confirm that the door locks and will not open. If the door does not lock, do not run Self-Clean. Contact service.

During Self-Clean, the oven is heated to a very high temperature. Soil is burned off at this temperature.

CAUTION

AVOID RISK OF DAMAGE

- Wipe out excessive spillage before self-cleaning the oven.
- Do not clean parts or accessories in the selfclean oven.

Self Clean

1. Remove all accessories and racks from the oven.
2. If there is a cooking mode on, press Oven Clear/Off to end the running mode.
3. Press the Self Clean button below the display. The Self Clean icon  appears in the display. The Self Clean timer default (4:00 hours) blinks to indicate it can be accepted or changed. To accept the 4:00 hour default Self Clean time, press Enter on the numeric keypad. To enter a different number of hours, use the numeric keypad. The value entered must be within the range of 2:00 to 4:00 hours. Entering a value less than 2:00 or greater than 4:00 results in an error tone and message.

Use a longer setting for a heavily soiled oven.



4. When the desired Self Clean time is displayed, press Enter on the numeric keypad. The oven door locks prior to starting Self Clean. The door lock symbol  is displayed and blinks while the door is being locked. Once locked, the door lock symbol is continuously illuminated but not blinking.

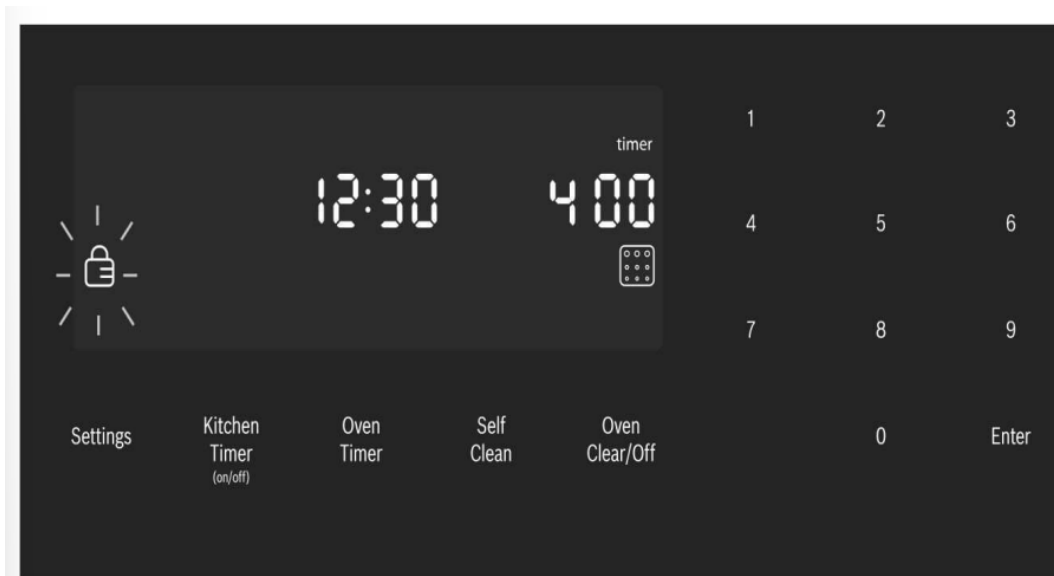

The door lock symbol remains illuminated as long as the Self Clean mode is running.

Note: The door remains locked until the oven has cooled down after self-cleaning. The door can be opened again only after “Self Clean” disappears from the display.

5. Self Clean starts and the oven Self Clean timer begins its countdown.

To Cancel Self Clean

Press the Oven Clear/Off button to cancel Self Clean. For Safety, when the Self Clean timer ends, the unit must cool down before the door can unlock. During this period the message “COOLING DOWN” is displayed.

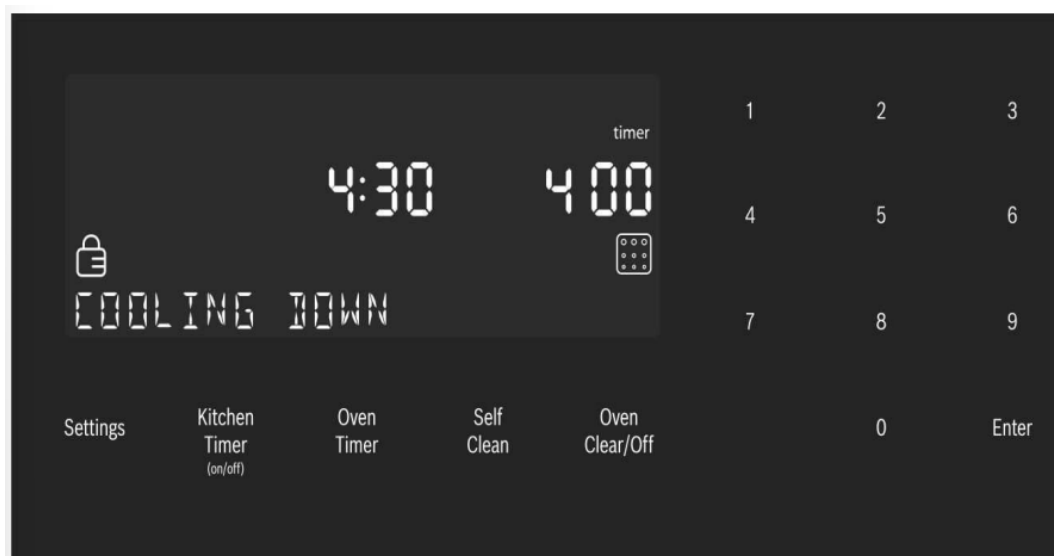

6. When the cool down is complete, the message “SELF CLEAN FINISHED” is displayed. Continue to use caution when opening the oven door.



7. Press Oven Clear/Off to clear the display when Self Clean is finished.

8. After the oven has cooled down and the door is unlocked, wipe remaining ash from the oven using a moist cloth.

Notes

- The oven light cannot be turned on during selfcleaning.
- The special heat-resistant enamel and the polished components in the oven can become discolored over time. This is normal and does not affect operation. Do not use scouring pads or abrasive cleaners to treat discolorations.

Avoid These Cleaners

Do not use commercial oven cleaners such as Easy Off®. They may damage the oven finish or parts.

Chlorine or chlorine compounds in some cleansers are corrosive to stainless steel. Check ingredients on label.

Never use scouring pads or abrasive cleaners.

Oven Cleaning Guide

Part	Recommendations
Flat Rack	<p>Wash with soapy water. Rinse thoroughly and dry, or gently rub with cleansing powder or soap-filled pads as directed. DO NOT clean the rack in the self-cleaning oven.</p> <p>If the flat racks are cleaned in the oven during the self-clean mode, they will lose their shiny finish and may not glide smoothly. If this happens, wipe the rack edges with a small amount of vegetable oil. Then wipe off excess.</p>
Telescopic Rack	<p>Wash with soapy water. Rinse thoroughly and dry, or gently rub with cleansing powder or soap-filled pads as directed. Avoid getting cleansing powder in the telescopic slides. Re-lubrication may become necessary. Use only high-temperature food-grade lubricants to re-lubricate slides.</p> <p>DO NOT clean the rack in the self-cleaning oven.</p>
Fiberglass Gasket	<p>Do Not Clean Door Gasket-The door gasket is essential for a good seal. Care should be taken not to rub, damage or move the gasket.</p>
Glass	<p>Wash with soap and water or glass cleaner. Use Fantastik® or Formula 409® to a clean sponge or paper towel and wipe clean. Avoid using powder cleaning agents, steel wool pads and oven cleaners.</p>
Painted Surfaces	<p>Clean with hot soapy water or apply Fantastik® or Formula 409® to a clean sponge or paper towel and wipe clean. Avoid using powder cleaning agents, steel wool pads and oven cleaners.</p>

Part	Recommendations
Porcelain Surfaces	Immediately wipe up acid spills like fruit juice, milk and tomatoes with a dry cloth. Do not use a moistened sponge/cloth on hot porcelain. When cool, clean with hot soapy water or apply Bon-Ami® or Soft Scrub® to a damp sponge. Rinse and dry. For stubborn stains, use soap-filled pads. It is normal for porcelain to show fine lines with age due to exposure to heat and food soil.
Stainless Steel Surfaces	Never allow food stains or salt to remain on stainless steel for any length of time. Always wipe or rub in the direction of the grain. Clean with a soapy sponge, then rinse and dry, or wipe with Fantastik® or Formula 409® sprayed on a paper towel. Protect and polish with Stainless Steel Magic® and a soft cloth. Remove water spots with a cloth dampened with white vinegar. Use Bar Keeper's Friend® to remove heat discoloration. Chlorine or chlorine compounds in some cleansers are corrosive to stainless steel. Check ingredients on label.
Black Stainless Surfaces	For black stainless steel and anti-fingerprint surfaces, use a soft, dry towel. For stubborn dirt, use warm water diluted with a non-abrasive, mild cleansing soap. Never use stainless steel polish.
Plastic & Controls	When cool, clean with soapy water, rinse and dry.
Probe	Wipe with soapy water. Do not submerge. Do not wash in the dishwasher.
Printed Areas (Words & Numbers)	Do not use abrasive cleaners or petroleum based solvents.

Maintenance

Replacing an Oven Light

CAUTION

WHEN REPLACING AN OVEN LIGHT:

- Make sure the appliance and lights are cool and power to the appliance has been turned off before replacing the light bulb(s). Failure to do so could result in electrical shock or burns.
- The lenses must be in place when using the appliance.
- The lenses serve to protect the light bulb from breaking.

- The lenses are made of glass. Handle carefully to avoid breaking. Broken glass could cause an injury.
- Light socket is live when door is open.

Bulb Specifications:

Bulb Description	Bulb Image
40 watt, appliance bulb, standard Edison base.	

To Change the Bulb:

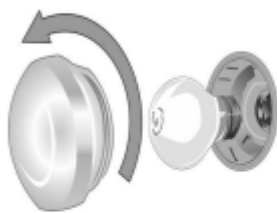

- Turn off the power to the oven at the main power supply (fuse or breaker box).
- Remove the glass cover by unscrewing it. Turn the glass counterclockwise to remove it.
- Remove the bulb. The bulb unscrews counterclockwise.
- Grasp the new bulb with a clean, dry cloth to prevent depositing skin oils on the glass which could lead to premature bulb failure. Replace the bulb by screwing it in turning the bulb clockwise.
- Screw the glass cover back on.
- Turn power back on at the main power supply (fuse or breaker box).

How to Remove the Oven Door

WARNING

- Make sure oven is cool and power to the oven has been turned off before removing the door. Failure to do so could result in electrical shock or burns.
- The oven door is heavy and parts of it are fragile. Use both hands to remove the oven door. The door front is glass. Handle carefully to avoid breakage.
- Grasp only the side of the oven door. Do not grasp the handle as it may swing in your hand and cause damage or injury.
- Failure to grasp the oven door firmly and properly could result in personal injury or product damage.

- To avoid injury from hinge bracket snapping closed, be sure both levers are securely in place before removing the door. Also, do not force door open or closed-the hinge could be damaged and injury could result.
- Do not lay removed door on sharp or pointed objects as this could break the glass. Lay on a flat, smooth surface, positioned so that the door cannot fall over.

To help avoid injury or damage, be sure to read the above WARNING before attempting to remove the oven door.

1. Open the oven door to its fully open position.
2. Flip levers on hinges toward you.

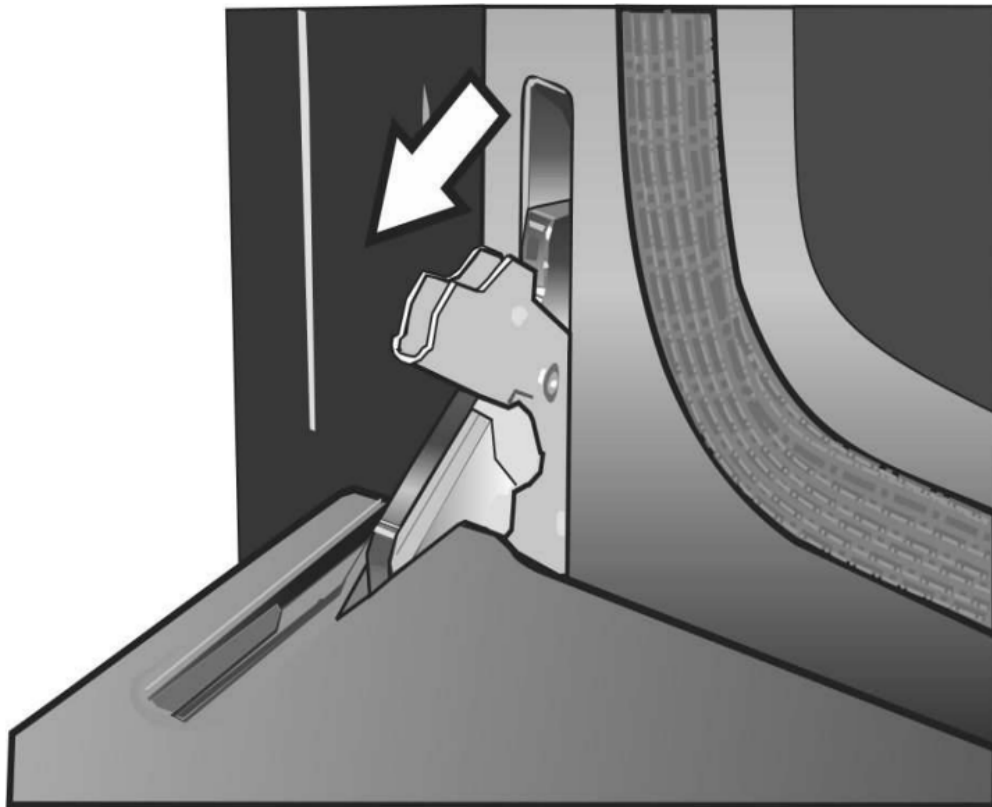

Note: It may be necessary to use a tool, such as a screwdriver, to gently pry the upper part of the lever away from the housing. Take care to avoid scratching the housing.

3. Bring both door hinge levers to their fullest down position as shown in the illustration. The left and right door hinges differ slightly but operate in the same manner.
4. Close the oven door until it catches on the hinge stop levers, locking the hinges at the proper angle for door removal. The door will be open about 7 inches at the top. This takes the spring tension off the hinges so the door can be easily lifted out.
5. The door is heavy. Use both hands to firmly grip it by the sides. Do not grip the door by the handle. Maintaining the door angle, lift the door straight up approximately 3/4" to unhook the

hinges from the slots and then pull it out towards you until the hinges are clear of the oven housing.



6. Place the door in a convenient and stable location for cleaning.

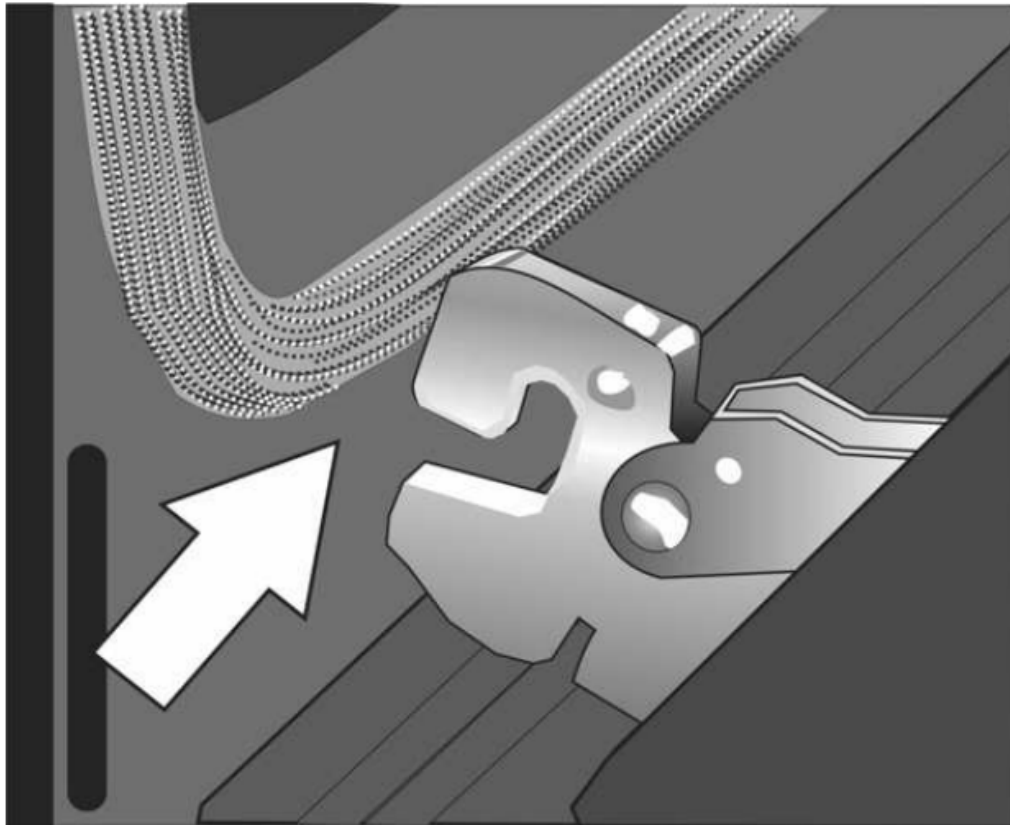

How to Replace the Oven Door

1. Holding the door firmly in both hands, grip it on either side, not by the handle.
2. Tilt the door back slightly towards you until it opens about 7 inches at the top.
3. Slide the hinges into the slots as far as they will go and then lower the door straight down. The angle of the door may need to be adjusted slightly to allow the hinges to engage properly and the door to lower into place. The door should lower about 3/4" and stop. If not, the hinges have not engaged properly and the door could fall if it is released.

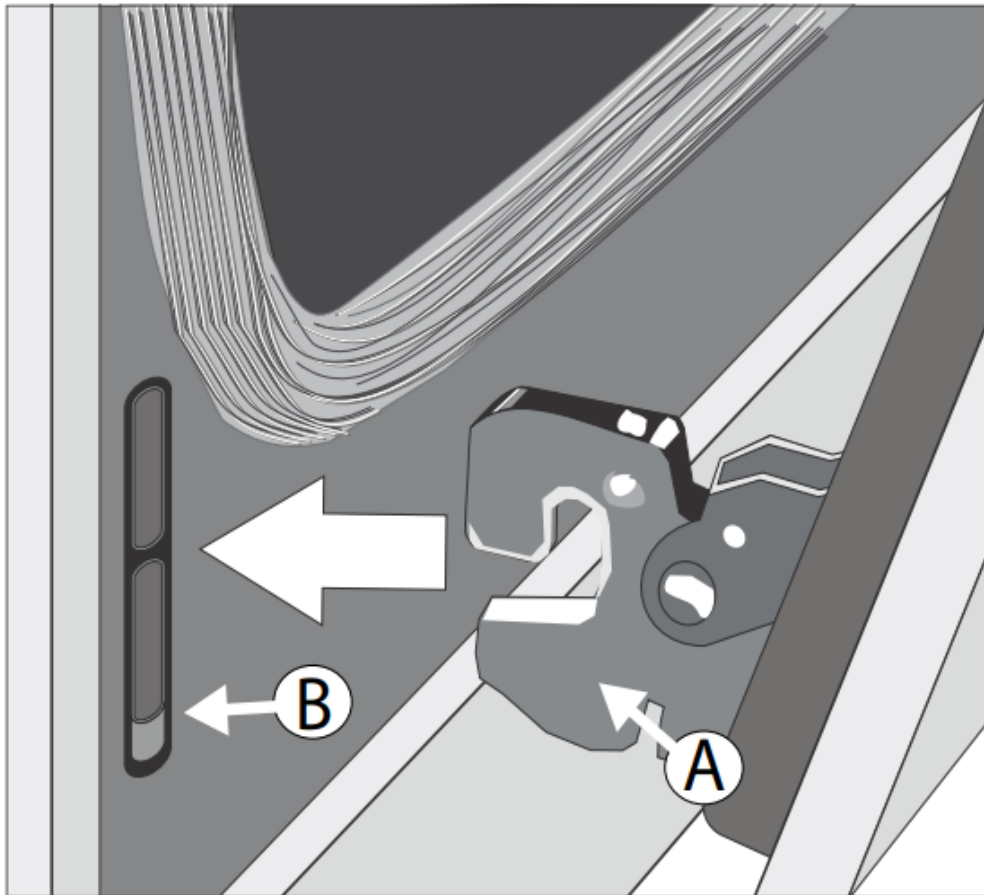

4. Once both hinges are fully engaged as described in Step 3, gently open the door until it is fully open.
5. Push the levers on both the hinges up and forward until they are locked into the slot and flush with the front of the oven body.

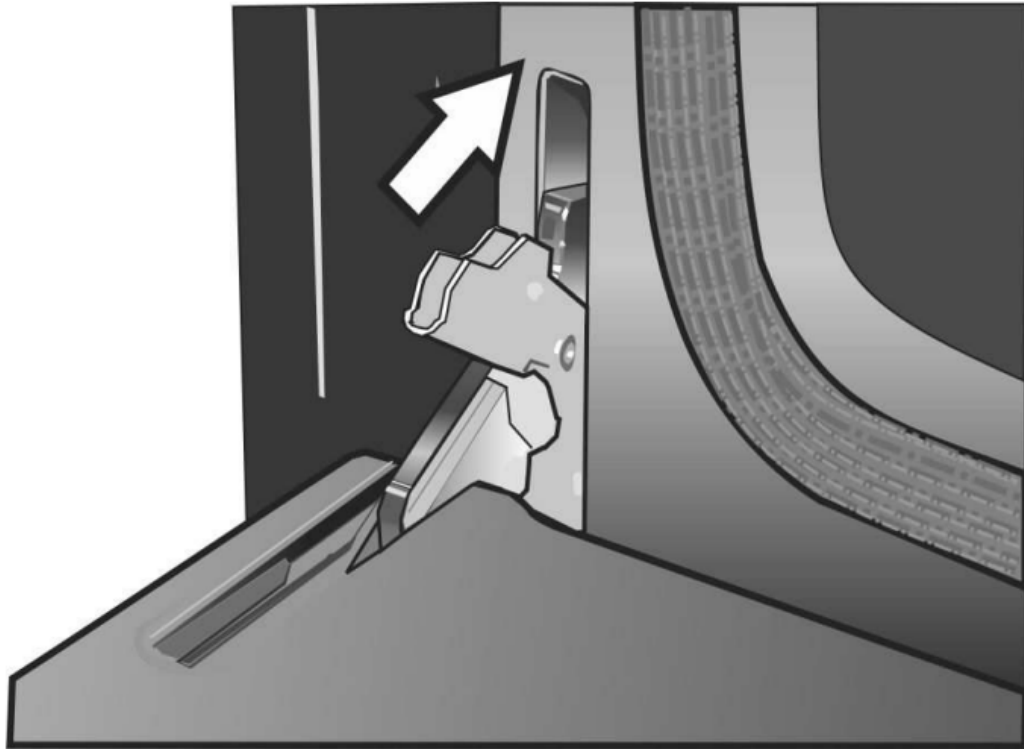

6. Close and open the door slowly to be sure it is correctly and securely in place.

Operation-Warming Drawer

This section explains how to operate the warming drawer. See “Getting the Most Out of Your Warming Drawer” for guidelines to improve warming drawer results.

About the Warming Drawer

The warming drawer will keep hot, cooked foods at serving temperature. Warming drawer settings are Low, Medium and High.

Warming Drawer Specifications

Drawer Interior: 25”W x 17”D x 3”H

Dish Sizes:

- 2- 9” x 13” Pyrex 3-quart dishes, side by side
- 2- 9 1/2” x 15” Pyrex 4 quart dishes, side by side
- 4- 10 1/2” plates, single or stacked
- 3- 11” plates, single or stacked

Operation

CAUTION

To maintain food safety, follow these guidelines:

- DO NOT use the warming drawer to heat cold food (exception: it is safe to use the drawer to crisp crackers, chips or dry cereal and to warm plates).
- Be sure to maintain proper food temperature. The USDA recommends holding hot food at 140°F or warmer.
- DO NOT warm food for longer than one hour.
- Plastic containers, plastic wrap or aluminum foil can melt if in direct contact with the drawer or a hot cooking container. If it melts onto the drawer, it may not be removable.

Preheating

For best results, preheat the warming drawer when warming food.

Preheat Times:

- Low: 10 minutes
- Medium: 15 minutes
- High: 20 minutes

Turning the Warming Drawer On and Off

1. Press the Warming Drawer button.
2. WARMING DRAWER will be displayed with the default setting “MED”. The warming drawer amber icon is displayed below the clock.
3. To accept the “MED” setting, press the Enter button. The setting is accepted and the warming drawer icon remains illuminated. If enter is not pressed, the warming drawer setting is not accepted and the warming drawer turns off.
4. To change the setting, when “MED” is displayed, press the Warming Drawer button again. The setting changes to “HIGH”. Press the Warming Drawer button again to change the setting to “LOW”.

To accept a setting press Enter.

The displayed setting will be accepted and the warming drawer icon is illuminated below the clock, indicating that the warming drawer is active.

5. To turn the warming drawer off, press the Warming Drawer button and the warming drawer will turn off. The warming drawer icon will no longer appear under the clock.

Sabbath Mode

The warming drawer may also operate in Sabbath Mode but ONLY while the oven is in Sabbath Mode. It is not possible to run Sabbath Mode in the warming drawer only. Simply start the desired warming drawer operation and then start Sabbath Mode in the oven cavity. The warming drawer

and oven will operate in Sabbath Mode until the timer reaches zero. It is not possible to change the warming drawer temperature while in Sabbath Mode.

Warming Empty Serving Bowls and Plates

- Use only heat-safe dishes.
- Warm on low setting for cooking containers.
- Check dish temperature during warming period.
- Place empty plates or dishes in a cold warming drawer. Do not preheat drawer prior to placing dishes.

Getting the Most Out of Your Warming Drawer

About the Appliance

The warming drawer will keep hot, cooked foods at serving temperature. Always start with hot food. DO NOT use to heat cold food. It is safe to use the drawer to crisp crackers, chips or dry cereal and to warm plates.

The warming drawer has a push-to-open feature. Push in the front of the drawer to activate opening.

General Tips

Refer to the Warming Drawer Chart for recommended settings.

- To keep several different foods hot, set the temperature for the food needing the highest setting.
- Place items needing the highest setting toward the side of the drawer and items needing less heat in the center of the drawer.
- Food should be at serving temperature (above 140°F) before being placed in the warming drawer. DO NOT use to heat cold food other than crisping crackers, chips and dry cereal or warming dishes or plates.
- Preheat empty serving dish while preheating drawer if desired.
- Place cooked, hot food in warming drawer in its original cooking container or in a heat-safe serving dish.
- Aluminum foil may be used to cover food. DO NOT line the warming drawer with aluminum foil.
- Do not use the warming drawer for storage.

Use of Your Appliance

CAUTION

To maintain food safety, do not leave food in the drawer for more than one hour before or after cooking.

IMPORTANT: Plastic containers or plastic wrap can melt if in direct contact with the drawer or a hot utensil. If it melts onto the drawer, it may not be removable.

Note: Use only heat-safe dishes.

Preheating

For best results, preheat the warming drawer when warming food.

Preheat Times:

- Low: 10 minutes
- Medium: 15 minutes
- High: 20 minutes

Warming Empty Serving Bowls and Plates

- Use only heat-safe dishes.
- Warm on low setting for cooking containers.
- Check dish temperature during warming period.
- Place empty plates or dishes in a cold warming drawer. Do not preheat drawer prior to placing dishes.

Crisping Stale Items

Place food in low-sided dishes or pans.

1. Press LOW.
2. Preheat for 10 minutes, then place dish in drawer.
3. Set the warming timer.
4. Check crispness after 45 minutes. Add time as needed.

Temperature Recommendations

Food/Cookware	Setting	Cover Dish
Bacon	HIGH	No
Beef, medium and well done	MED	No
Beef, medium rare	LOW	No
Bread, hard rolls	MED	No
Bread, soft rolls, coffee cakes	MED	Yes
Biscuits	MED	Yes
Casseroles	MED	Yes
Eggs	MED	Yes
Fish, seafood	MED	Yes
Fried foods	HIGH	No
Gravy, cream sauces	MED	Yes
Ham	MED	Yes
Pancakes	HIGH	Yes
Pies, one crust	MED	Yes
Pies, two crusts	MED	No
Pizza	HIGH	No
Pork	MED	Yes
Potatoes, baked	HIGH	Yes
Potatoes, mashed	MED	Yes
Poultry, roasted	MED	Yes
Vegetables	MED	Yes
Plates	LOW	No
Plate of food	MED	Yes

Gravy, cream sauces	MED	Yes
Ham	MED	Yes
Pancakes	HIGH	Yes
Pies, one crust	MED	Yes
Pies, two crusts	MED	No
Pizza	HIGH	No
Pork	MED	Yes
Potatoes, baked	HIGH	Yes
Potatoes, mashed	MED	Yes
Poultry, roasted	MED	Yes
Vegetables	MED	Yes
Plates	LOW	No
Plate of food	MED	Yes

Cleaning and Maintenance-Warming Drawer

CAUTION To prevent burns, do not remove drawer while hot. Be sure drawer is empty before removing.

Note: The warming drawer is opened with a Push-ToOpen mechanism. It is referred to in this chapter as a PTO mechanism.

Cleaning the Warming Drawer

Part	Recommendations
Drawer Interior (polished stainless steel)	Use dish detergent. Wash, rinse well and dry. For hard water spots or scale, use white vinegar. Apply with a sponge or cloth, rinse and dry. Chlorine or chlorine compounds in some cleansers are corrosive to stainless steel and can cause injury. Check ingredients on label.
Painted Surfaces	Use hot, soapy water or mild cleaners such as Fantastik® or Formula 409®. Wash, rinse well and dry. Avoid using abrasive cleaning agents, steel wool pads and oven cleaners.
Drawer Exterior Frame (brushed stainless steel)	Always wipe or rub in the direction of the grain. Clean with a soapy sponge, then rinse and dry or wipe with Fantastik® or Formula 409® sprayed on a paper towel. Protect and polish with Stainless Steel Magic® and a soft cloth. Remove water spots with a cloth dampened with white vinegar. Use Bar Keeper's Friend® to remove heat discoloration. Chlorine or chlorine compounds in some cleansers are corrosive to stainless steel. Check ingredients on label.

Removing Drawer from Housing

NOTICE: The following is the manufacturer's recommendations for removing and installing the drawer to minimize the risk of damage to the PTO mechanism.

1. Remove the drawer from the drawer housing.
 - Pull drawer to fully open position.
 - Press down right drawer release lever.
 - Lift up left drawer release lever.
 - Firmly pull the drawer straight out.
 - Retract cabinet rails while drawer is removed.

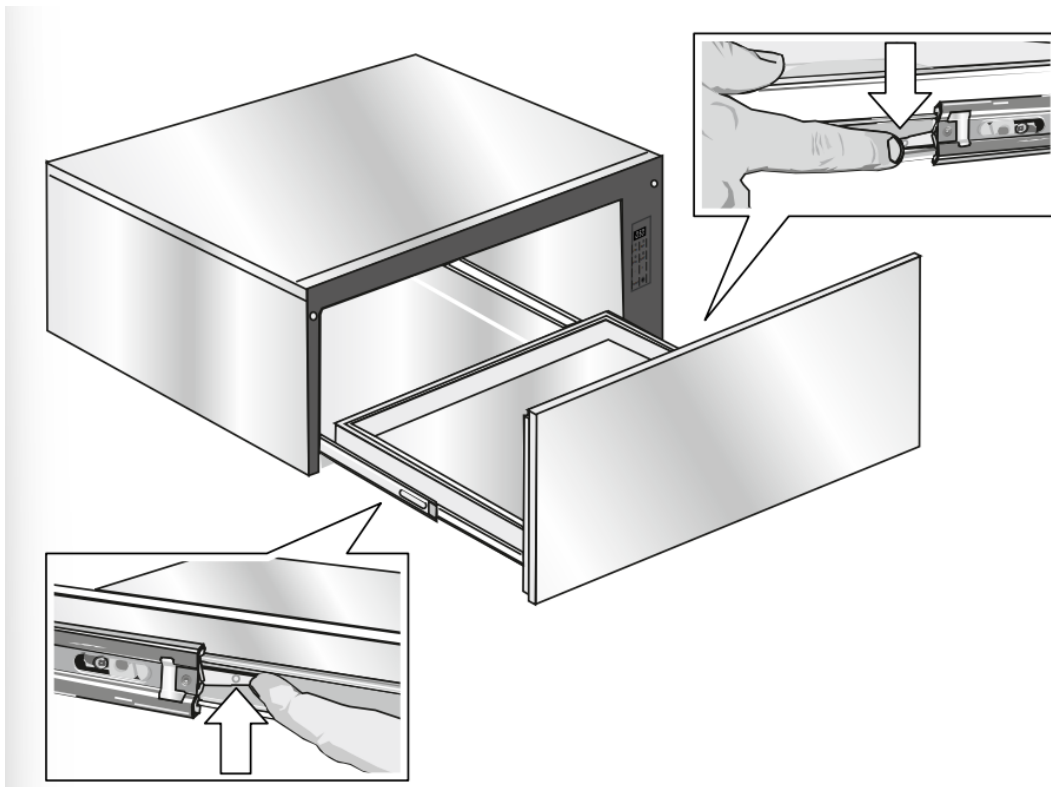

2. Grasp both sides of the drawer and pulling straight and level, carefully remove the drawer housing. This step may require light to moderate force to completely remove drawer.

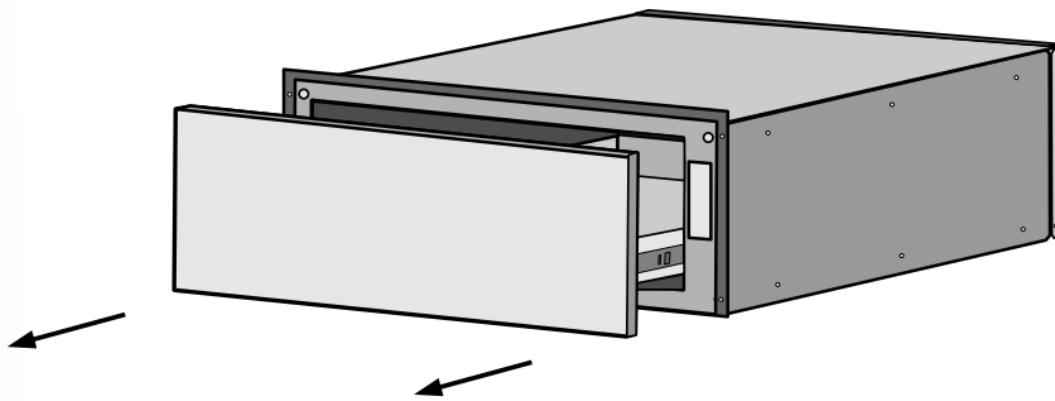

3. Install or service (clean) housing with drawer removed.

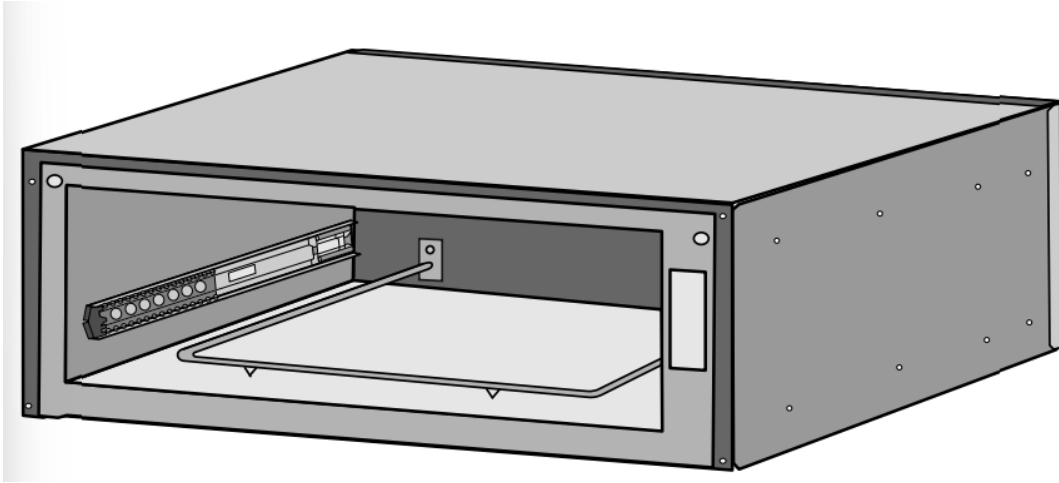

Installing Drawer to Housing

The slides mounted to each side of the housing wall have two moving components, an inner rail and a ball bearing carrier which need to be in the proper orientation for accurate installation and alignment. There is also a visible locking mechanism located at the rear of each slide.

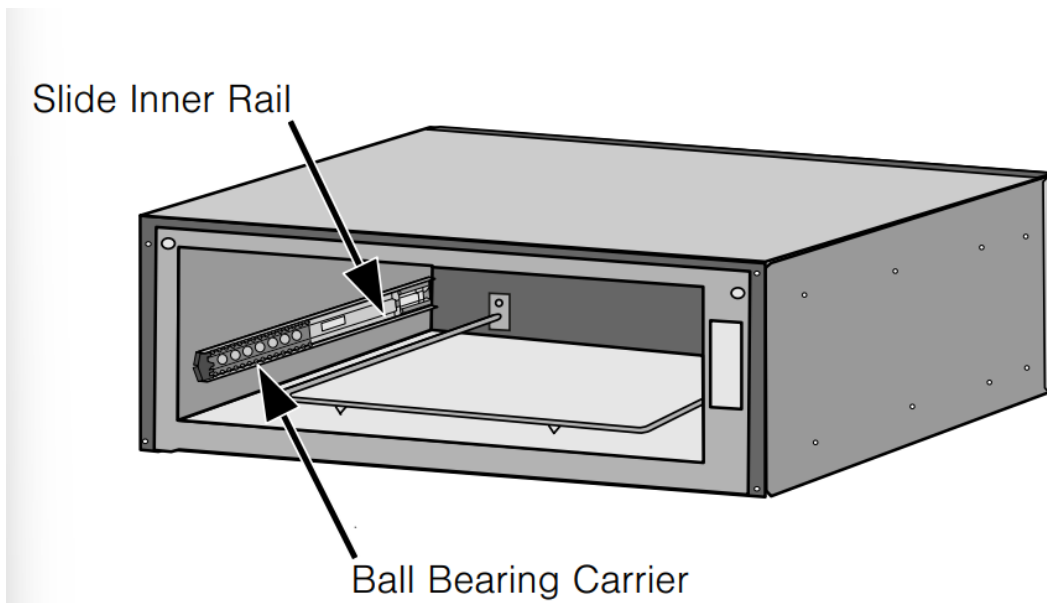

Note: The housing of your warming drawer should match the image below identically before starting your installation. The ball bearing carrier should be locked in to the inner rail's black plastic rail tip at the front of the inner rail.

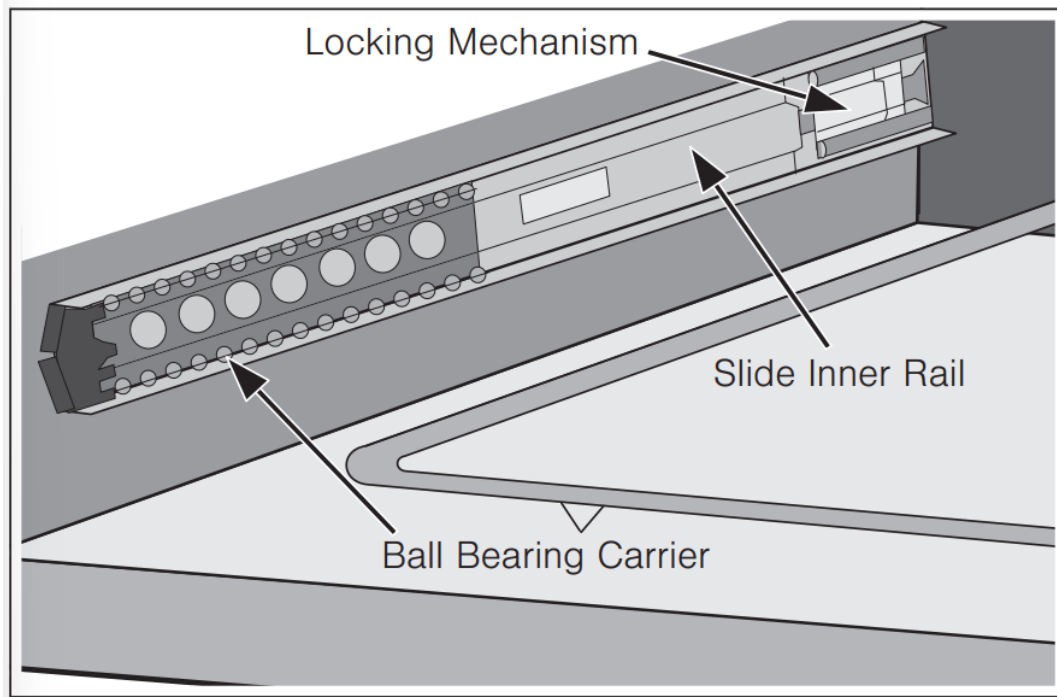

1. With the drawer removed, set the slide inner rail to the drawer locked position by pushing the slide inner rail toward the rear of the housing until it locks in place.

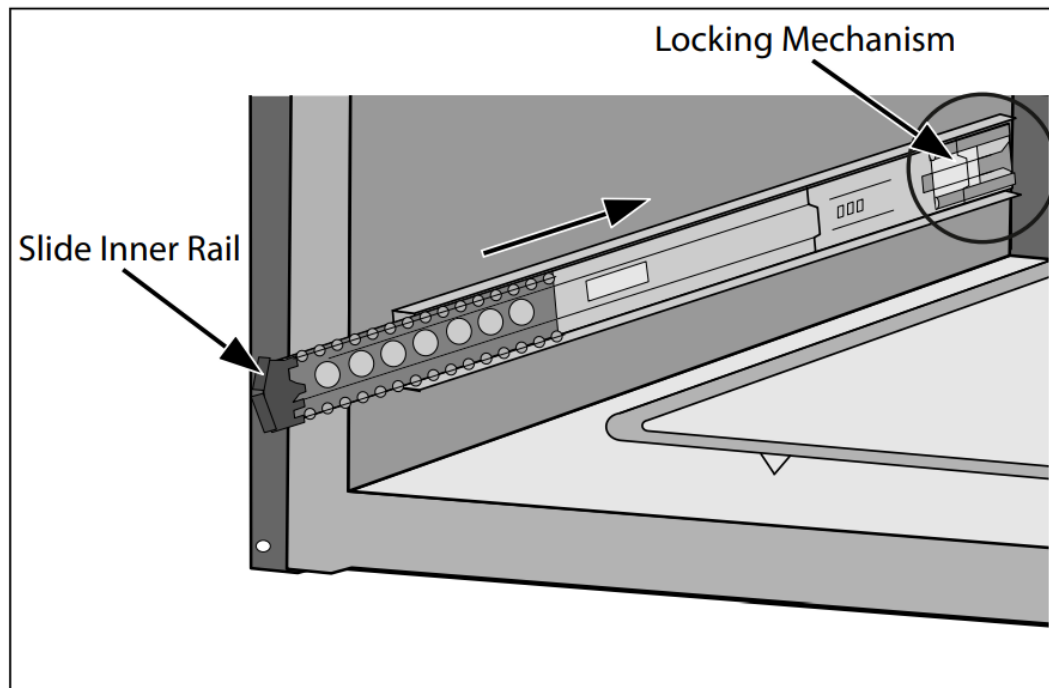

Note: A moderate force pushing on the black plastic ball carrier locking mechanism is required to set the slide to the drawer locked position. The drawer is locked when it remains in place and does not spring back to the open position.

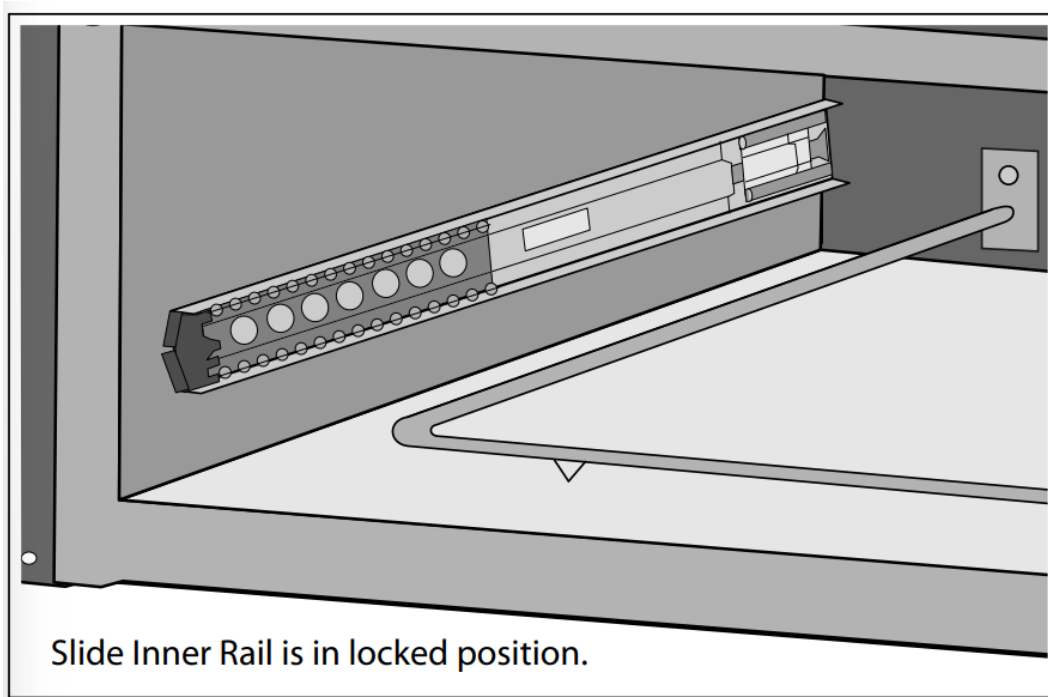

2. Position the drawer assembly in front of the housing assembly and align the rail (plastic rail tip) to the slide ball carrier assembly. Keeping the drawer assembly level and square to the housing, gently insert the drawer to the housing assembly.

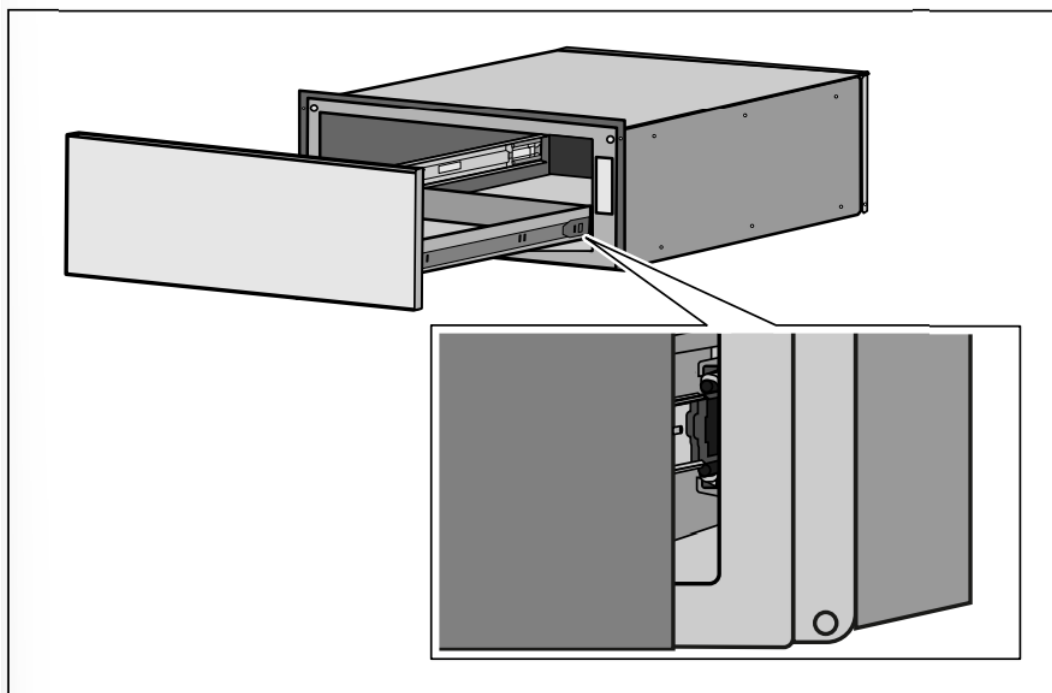

Notes

- A slight side-to-side wiggle motion may be required to properly get the ball bearings to accurately align.

- Remember: You are attempting to align two sets of ball bearings at this point. If more than a moderate force is required to insert the drawer at this time, remove the drawer and repeat the installation procedure to this point.

3. Continue to insert the drawer keeping the drawer level and square to the housing until a slight increase in resistance is felt at the approximate position shown below.

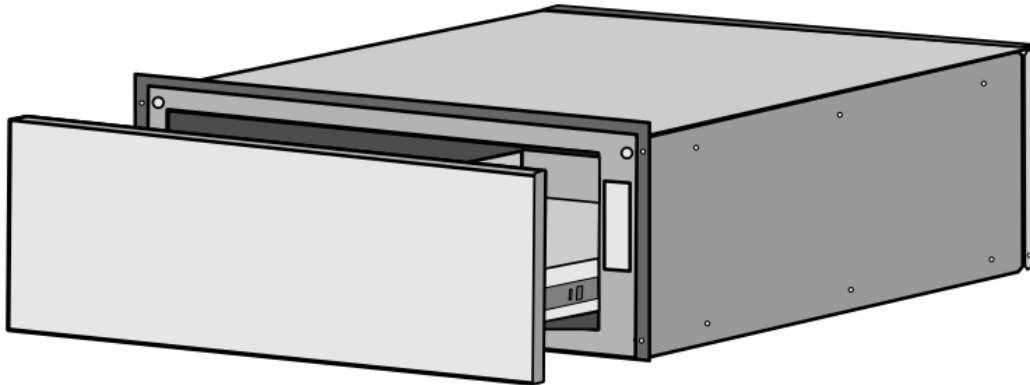

NOTICES

- At this position, a slight increase in closure force is required with several small increments of force applied to the drawer to accurately align and set the drawer for proper operation.
- An audible “click” should be heard when the drawer is properly closed causing the drawer to lock in the closed position.

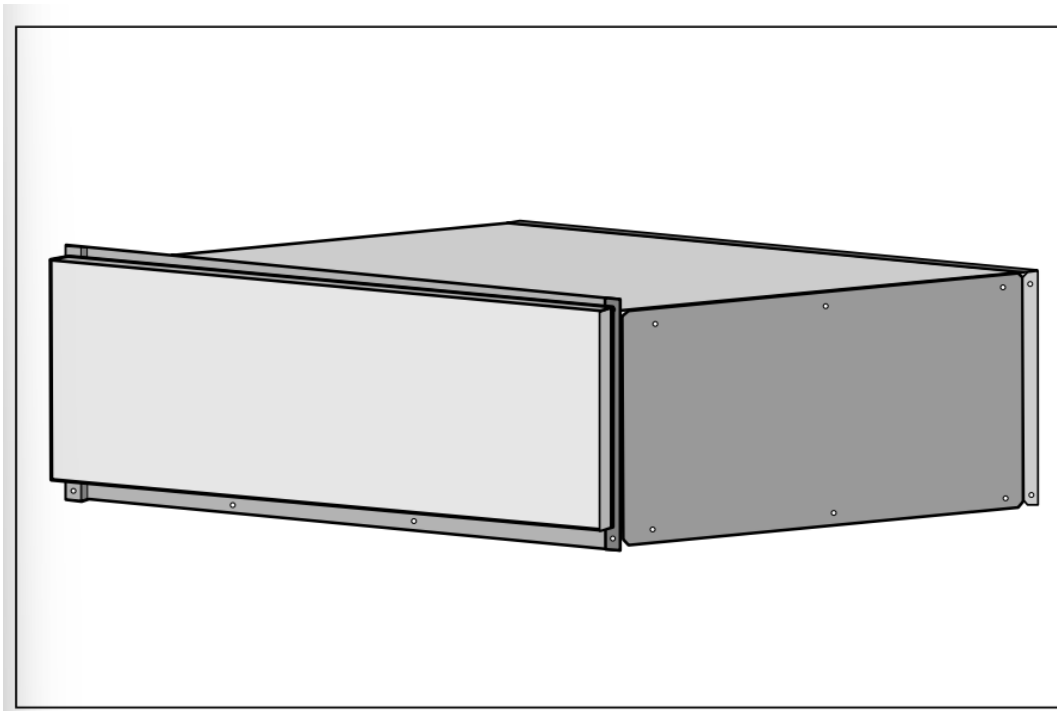

4. Test the operation of the PTO drawer by pushing on the center lower portion of the drawer front (optimum location for function).

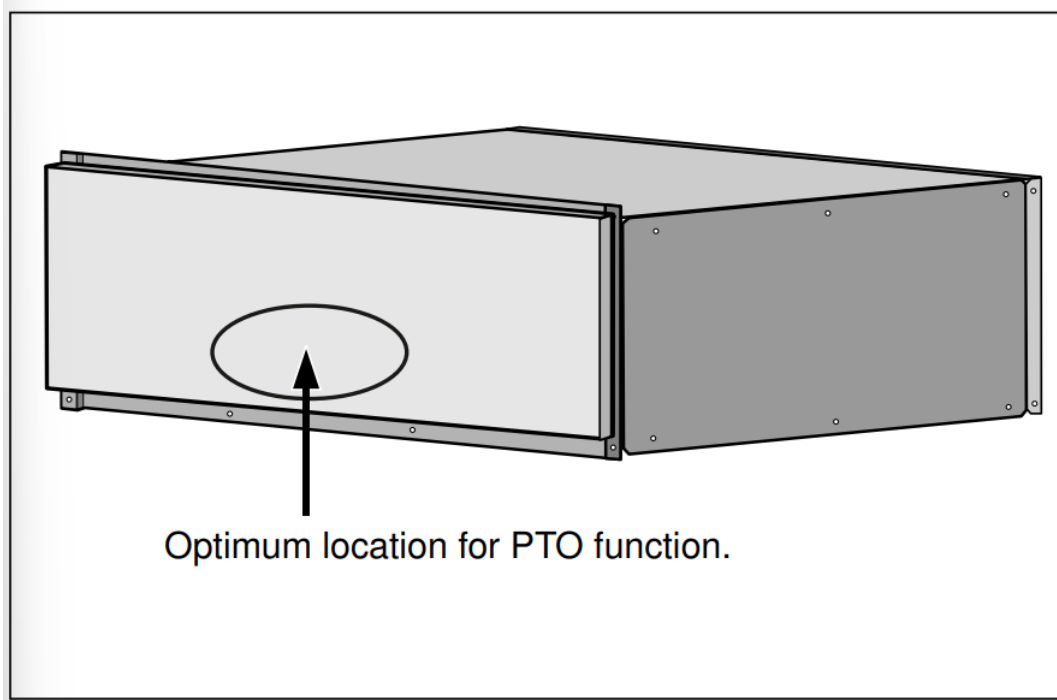

Note: It should be noted the recommended and optimum location for opening the drawer is the lower center front. The drawer will operate with an opening force applied to any location on the drawer front, however a slight increase in opening force may be required.

Service

Frequently-asked questions and answers (FAQ)

Using the appliance

- Why can't I switch on the cooktop and why is the panel lock symbol lit?

The panel lock is activated.

You can find information about this function in section ~ "Panel lock"

- Why are the displays flashing and why can I hear an acoustic signal?

Remove any liquid or food remains from the control panel. Remove any objects from the control panel.

You can find instructions on how to deactivate the audible signal in the section on ~ "Basic settings"

Noises

- Why I can hear noises while I'm cooking?

Noises may be generated while using the cooktop depending on the base material of the cookware. These noises are a normal part of induction technology. They do not indicate a defect.

Possible noises:

- A low humming noise like the one a transformer makes:

Occurs when cooking at a high heat setting. The noise disappears or becomes quieter when the heat setting is reduced.

- Low whistling noise:

Occurs when the cookware is empty. This noise disappears when water or food is added to the cookware.

- Crackling:

Occurs when using cookware made from different layers of material or when using cookware of different sizes and different materials at the same time. The volume of the noise can vary depending on the quantity of food being cooked or the cooking method.

- High-pitched whistling noises:

Can occur when two elements are used on the highest heat setting at the same time. The whistling noises disappear or become quieter when the heat setting is reduced.

- Fan noise:

The cooktop is equipped with a fan that switches on automatically at high temperatures. The fan may continue to run even after you have switched off the cooktop if the temperature detected is still too high.

Cookware

- Which types of cookware can be used with an induction cooktop?

You can find information on which types of cookware can be used with an induction cooktop in the section on ~ "Cooking with Induction".

- Why is the element not heating up and why is the heat setting flashing?

The element on which the cookware is standing is not turned on.

Check that you have turned on the correct element.

The cookware is too small for the element that is turned on or it is not suitable for induction cooking.

Check that the cookware is suitable for induction cooking and that it is placed on the element that best corresponds to its size. You can find information on the type, size and positioning of cookware in the sections on ~ "Cooking with Induction".

- Why is it taking so long for the cookware to heat up or why is it not heating up sufficiently despite being on a high heat setting?

The cookware is too small for the element that is turned on or it is not suitable for induction cooking. Check that the cookware is suitable for induction cooking and that it is placed on the element that best corresponds to its size. You can find information on the type, size and positioning of cookware in the sections on ~ "Cooking with Induction".

Cleaning

- How do I clean the cooktop?

Using a special glass-ceramic cleaning agent produces the best results. We advise against using harsh or abrasive cleaning agents, dishwasher detergent (concentrated) or scouring pads.

You can find more information about cleaning and caring for your cooktop in the section on "Cleaning and Maintenance-Cooktop."

Fixing Malfunctions

Malfunctions are usually due to small details. Before calling Customer Support, you should consider the following advice and warnings.

CAUTION Repairs should only be done by an authorized servicer. Improper repair of your appliance may result in risk of severe physical injury or death.

Display	Possible cause	Solution
None	The power supply has been disconnected. The device has not been connected in accordance with the connection diagram. Electronics error.	Use other electrical devices to check whether a short-circuit has occurred in the power supply. Ensure that the device has been connected in accordance with the connection diagram. If the error cannot be eliminated, inform the technical after-sales service.
The displays flash	The control panel is damp or an object is covering it.	Dry the control panel or remove the object.
The – indicator flashes in the element displays	An error has occurred in the electronics.	To confirm the error, cover the control panel with your hand.
<i>F2</i>	The electronics have overheated and have switched off the corresponding element.	Wait until the electronics have cooled down sufficiently. Then touch any symbol on the cooktop.
<i>F4</i>	The electronics have overheated and have switched off all elements.	
<i>F5</i> + heat setting and acoustic signal	There is a hot pan in the area of the control panel. There is a risk that the electronics will overheat.	Remove the pan. The error display goes out shortly afterwards. You can continue to cook.
<i>F5</i> and acoustic signal	There is a hot pan in the area of the control panel. To protect the electronics, the element has been switched off.	Remove the pan. Wait for a few seconds. Touch any control. If the error display goes out, you can continue to cook.
<i>F1/F6</i>	The element has overheated and switched itself off to protect the work surface.	Wait until the electronics have cooled down sufficiently and switch the element on again.
<i>F8</i>	The element was operating for an extended period without interruption.	The automatic safety switch-off function has been activated. See section "Automatic time limitation"
Do not place hot pans on the control panel.		
Display	Possible cause	Solution
<i>E9000</i> <i>E9010</i> <i>E9011</i>	The supply voltage is incorrect; outside of the normal operating range.	Contact your electrical utility provider.
<i>dE</i>	The demo mode is activated	Disconnect the cooktop from the power supply. Ensure that it has been connected in accordance with the connection diagram. Disconnect the cooktop from the power supply. Wait 30 seconds and reconnect it. Touch any touch control in the next three minutes. The demo mode is deactivated.
Do not place hot pans on the control panel.		

Notes

If “ appears on the display, the sensor for the element in question must be held down in order to be able to read off the fault code.

If the fault code is not listed in the table, disconnect the cooktop from the power supply, wait 30 seconds, and then reconnect it again. If the display appears again, contact Technical Assistance Service and tell them the precise fault code.

Suitability test of cookware

This function can be used to check the speed and quality of the cooking process depending on the cookware. The result is a reference value and depends on the properties of the cookware and the element being used.

1. With the cookware still cold, fill it with approx. 8 oz. (200 ml) of water and place it on the center of the cooking zone with the diameter that most closely matches that of the base of the cookware.
2. Go to the basic settings and select the TM, f setting.

3. Touch the settings range. A will flash on the cooking zone display. The function has now been activated. After 10 seconds, the result for the quality and speed of the cooking process will appear on the cooking zone display.

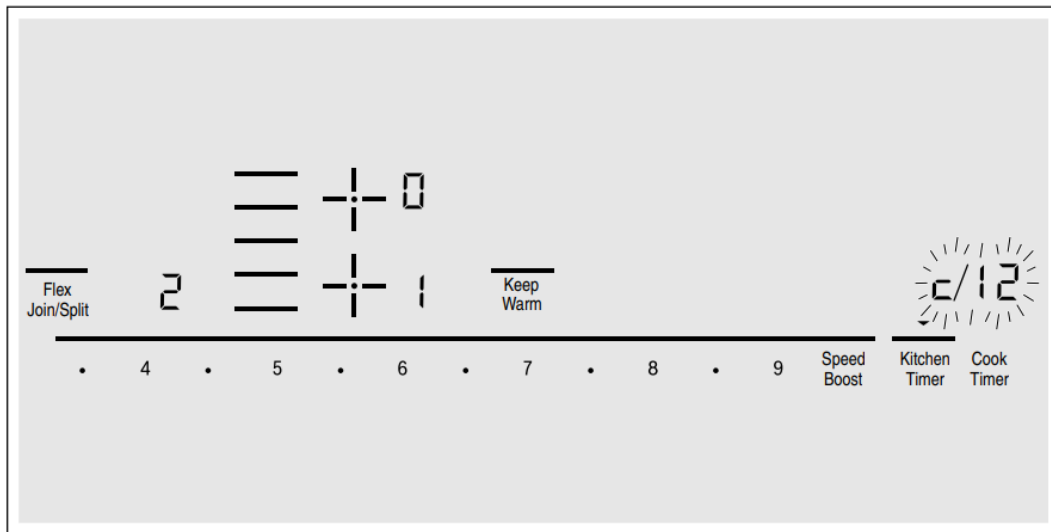

Check the result using the table below:

Result	
	The cookware is not suitable for the element and will therefore not heat up.*
	The cookware is taking longer to heat up than expected and the cooking process is not going as well as it ought to.*
	The cookware is heating up correctly and cooking is progressing well.
* If there is a smaller element available, try the cookware again on the smaller element.	

To reactivate this function, touch the settings range.

Notes

- The flexible cooking zone only counts as a single element; place no more than one item of cookware on it.
- If the diameter of the used cooking zone is much smaller than the diameter of the cookware, only the middle of the cookware can be expected to heat up. This may result in the cooking results not being as good as expected or being less than satisfactory.
- You can find information on this function in the section ~ "Basic settings"

- You can find information on the type, size and positioning of the cookware in the section “Cookware”.

Oven Troubleshooting

Use these suggestions before calling for service to avoid service charges.

Oven Problem	Possible Causes and Suggest Solutions
The oven mode or temperature selected or the numbers selected do not appear in the display	Review manual instructions when setting clock, timer, or Self Clean.
Oven door is locked and will not release, even after cooling	Turn the oven off at the circuit breaker and wait 5 minutes. Turn breaker back on. The oven should reset itself and will be operable.
Oven is not heating	Check circuit breaker or fuse box to your house. Make sure there is proper electrical power to the oven. Be sure oven temperature has been selected.
Oven is not cooking evenly	Adjust oven calibration if necessary (see “Change the Oven Temperature Offset” in this manual). Refer to cooking charts for recommended rack position.
Baking results are not as expected	Refer to cooking charts for recommended rack position. Check “Getting the Most out of Your Oven” for tips and suggestions. Adjust oven calibration if necessary (see “Change the Oven Temperature Offset” in this manual).
Food takes longer to cook than expected	The oven is carefully calibrated to provide accurate results. However, the temperature can be offset if food is consistently too brown or too light. See “Change the Oven Temperature” Offset”.
Food is overcooked	The oven is carefully calibrated to provide accurate results. However, the temperature can be offset if food is consistently too brown or too light. See “Change the Oven Temperature” Offset”.
Convection Bake or Convection Multi-Rack Results are not as Expected	If the Automatic Convection Conversion Feature is turned off, the temperature must be manually reduced by 25°F. If the feature is active, the temperature is automatically adjusted. See “Turn Automatic Convection Conversion ON or OFF” for more information. Refer to cooking charts and tips for rack positions, cooking times and pan selection. Adjust oven calibration if necessary. See “Change the Oven Temperature” Offset”.
Oven temperature is too hot or too cold	The oven thermostat needs adjustment. See Oven Temperature Offset. See “Change the Oven Temperature” Offset”.



Oven light is not working properly	Replace or reinsert the light bulb if loose or defective. Touching the bulb with fingers may cause the bulb to burn out.
Oven light will not turn off	Check for obstruction in oven door. Check to see if hinge is bent. When the Sabbath feature is activated, the oven light will stay on or off (as selected during set-up) during the entire Sabbath Mode.
Cannot remove lens cover on light	There may be soil build-up around the lens cover. Wipe lens cover area with a clean dry towel prior to attempting to remove the lens cover.
Oven will not Self Clean properly	Allow the oven to cool before running Self Clean. Always wipe out loose soils or heavy spillovers before running Self Clean. If oven is badly soiled, set oven for a four-hour Self Clean. See Preparing the Oven to Self Clean.
Clock and timer are not working properly	Make sure there is electrical power to oven. See Clock and Timer sections.
Porcelain chips	When oven racks are removed and replaced, always tilt racks upward and do not force them to avoid chipping the porcelain.
"F" and a number appears in display and control beeps	This is a fault code. Press Off to clear the display and stop beeping. Reset oven if necessary. If fault code remains and beep continues, record fault code, cancel oven and call authorized service technician.
With a new range there is a strong odor when oven is turned on	This is normal with a new range and will disappear after a few uses. Operating the Self Clean cycle will also "burn-off" the smell more quickly.
Control does not react when the pad is touched	Be sure that pad is clean. Touch the center of the button. Use the flat part of your finger.
Fan is running during modes that don't use convection	On some models, the convection fan will run while the oven is preheating for the bake mode. This is normal. Slide-in models also have a cooling fan that runs during every cooking mode.
Warm air or steam escapes from oven vent	It is normal to see or feel steam or warm air escaping from the oven vent. Do not block the vent.
Cooling fan runs after oven is turned off (Slide-in ranges only)	This is normal. When the oven has cooled to a pre-determined temperature, the cooling fan turns off

The cooktop does not operate during Self Clean	This is normal for some models. Operation will return once Self Clean is complete.
--	--

How to Obtain Service or Parts

To reach a service representative, see the contact information at the front of the manual. Please be prepared with the information printed on your rating label when calling.

Rating Label

The rating label shows the model and FD number. Refer to the rating label on the appliance when requesting service. The rating label is located on the back side of the drawer front. Open the drawer to view it.

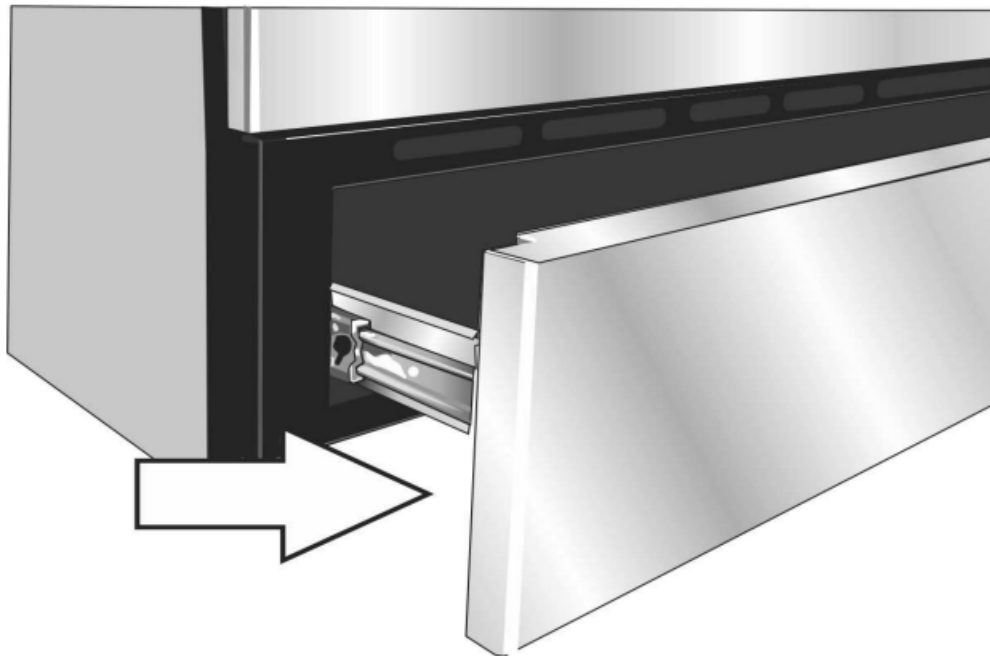

Model number and FD number

The model number and the FD number of your appliance are found on the rating label. Make a note of these numbers in the space below to save time in the event your appliance requires service.

Model #	FD #
Bosch Customer Support ☎ 800-944-2904	



STATEMENT OF LIMITED PRODUCT WARRANTY

What this Warranty Covers & Who it Applies to

The limited warranty provided by BSH Home Appliances Corporation ("BSH") in this Statement of Limited Product Warranty applies only to the Bosch appliance ("Product") sold to you, the first using purchaser, provided that the Product was purchased:

- For your normal, household (non-commercial) use, and has in fact at all times only been used for normal household purposes.
- New at retail (not a display, "as is", or previously returned model), and not for resale, or commercial use.
- Within the United States or Canada, and has at all times remained within the country of original purchase.

The warranties stated herein apply to the original purchaser of the product warranted herein and to each succeeding owner of the product purchased for ordinary home use during the term of the warranty. Please make sure to return your registration card; while not necessary to effectuate warranty coverage, it is the best way for BSH to notify you in the unlikely event of a safety notice or product recall.

How Long the Warranty Lasts

BSH warrants that the Product is free from defects in materials and workmanship for a period of three hundred sixty-five (365) days from the date of purchase. The foregoing timeline begins to run upon the date of purchase, and shall not be stalled, tolled, extended, or suspended, for any reason whatsoever.

This Product is also warranted to be free from cosmetic defects in material and workmanship (such as scratches of stainless steel, paint/porcelain blemishes, chip, dents, or other damage to the finish of the Product), for a period of thirty (30) days from the date of purchase or closing date for new construction. This cosmetic warranty excludes slight color variations due to inherent differences in painted and porcelain parts, as well as differences caused by kitchen lighting, product location, or other similar factors. This cosmetic warranty specifically excludes any display, floor, "As Is", or "B" stock appliances.

Repair/Replace as Your Exclusive Remedy

During this warranty period, BSH or one of its authorized service providers will repair your Product without charge to you (subject to certain limitations stated herein) if your Product proves to have been manufactured with a defect in materials or workmanship. If reasonable attempts to repair the Product have been made without success, then BSH will replace your Product (upgraded models may be available to you, in BSH's sole discretion, for an additional charge). All removed parts and components shall become the property of BSH at its sole option. All replaced and/or repaired parts

shall assume the identity of the original part for purposes of this warranty and this warranty shall not be extended with respect to such parts. BSH's sole liability and responsibility hereunder is to repair manufacturer-defective Product only, using a BSH-authorized service provider during normal business hours. For safety and property damage concerns, BSH highly recommends that you do not attempt to repair the Product yourself, or use an un-authorized servicer; BSH will have no responsibility or liability for repairs or work performed by a non-authorized servicer. If you choose to have someone other than an authorized service provider work on your Product, THIS WARRANTY WILL AUTOMATICALLY BECOME NULL AND VOID. Authorized service providers are those persons or companies that have been specially trained on BSH products, and who possess, in BSH's opinion, a superior reputation for customer service and technical ability (note that they are independent entities and are not agents, partners, affiliates or representatives of BSH). Notwithstanding the foregoing, BSH will not incur any liability, or have responsibility, for the Product if it is located in a remote area (more than 100 miles from an authorized service provider) or is reasonably inaccessible, hazardous, threatening, or treacherous locale, surroundings, or environment; in any such event, if you request, BSH would still pay for labor and parts and ship the parts to the nearest authorized service provider, but you would still be fully liable and responsible for any travel time or other special charges by the service company, assuming they agree to make the service call.

Out of Warranty Product

BSH is under no obligation, at law or otherwise, to provide you with any concessions, including repairs, prorates, or Product replacement, once this warranty has expired.

Warranty Exclusions

The warranty coverage described herein excludes all defects or damage that are not the direct fault of BSH, including without limitation, one or more of the following:

- Use of the Product in anything other than its normal, customary and intended manner (including without limitation, any form of commercial use, use or storage of an indoor product outdoors, use of the Product in conjunction with air or water-going vessels).
- Any party's willful misconduct, negligence, misuse, abuse, accidents, neglect, improper operation, failure to maintain, improper or negligent installation, tampering, failure to follow operating instructions, mishandling, unauthorized service (including selfperformed "fixing" or exploration of the appliance's internal workings).
- Adjustment, alteration or modification of any kind.
- A failure to comply with any applicable state, local, city, or county electrical, plumbing and/or building codes, regulations, or laws, including failure to install the product in strict conformity with local fire and building codes and regulations.
- Ordinary wear and tear, spills of food, liquid, grease accumulations, or other substances that accumulate on, in, or around the Product.

- Any external, elemental and/or environmental forces and factors, including without limitation, rain, wind, sand, floods, fires, mud slides, freezing temperatures, excessive moisture or extended exposure to humidity, lightning, power surges, structural failures surrounding the appliance, and acts of God.

In no event shall BSH have any liability or responsibility whatsoever for damage to surrounding property, including cabinetry, floors, ceilings, and other structures or objects around the Product. Also excluded from this warranty are Products on which the serial numbers have been altered, defaced, or removed; service visits to teach you how to use the Product, or visits where there is nothing wrong with the Product; correction of installation problems (you are solely responsible for any structure and setting for the Product, including all electrical, plumbing or other connecting facilities, for proper foundation/flooring, and for any alterations including without limitation cabinetry, walls, floors, shelving, etc.); and resetting of breakers or fuses. TO THE EXTENT ALLOWED BY LAW, THIS WARRANTY SETS OUT YOUR EXCLUSIVE REMEDIES WITH RESPECT TO PRODUCT, WHETHER THE CLAIM ARISES IN CONTRACT OR TORT (INCLUDING STRICT LIABILITY, OR NEGLIGENCE) OR OTHERWISE. THIS WARRANTY IS IN LIEU OF ALL OTHER WARRANTIES, WHETHER EXPRESS OR IMPLIED. ANY WARRANTY IMPLIED BY LAW, WHETHER FOR MERCHANTABILITY OR FITNESS FOR A PARTICULAR PURPOSE, OR OTHERWISE, SHALL BE EFFECTIVE ONLY FOR THE PERIOD THAT THIS EXPRESS LIMITED WARRANTY IS EFFECTIVE. IN NO EVENT WILL THE MANUFACTURER BE LIABLE FOR CONSEQUENTIAL, SPECIAL, INCIDENTAL, INDIRECT, "BUSINESS LOSS", AND/OR PUNITIVE DAMAGES, LOSSES, OR EXPENSES, INCLUDING WITHOUT LIMITATION TIME AWAY FROM WORK, HOTELS AND/ OR RESTAURANT MEALS, REMODELLING EXPENSES IN EXCESS OF DIRECT DAMAGES WHICH ARE DEFINITELY CAUSED EXCLUSIVELY BY BSH, OR OTHERWISE. SOME STATES DO NOT ALLOW THE EXCLUSION OR LIMITATION OF INCIDENTAL OR CONSEQUENTIAL DAMAGES, AND SOME STATES DO NOT ALLOW LIMITATIONS ON HOW LONG AN IMPLIED WARRANTY LASTS, SO THE ABOVE LIMITATIONS MAY NOT APPLY TO YOU. THIS WARRANTY GIVES YOU SPECIFIC LEGAL RIGHTS, AND YOU MAY ALSO HAVE OTHER RIGHTS WHICH VARY FROM STATE TO STATE. No attempt to alter, modify or amend this warranty shall be effective unless authorized in writing by an officer of BSH.

Warning

This content is compiled from multiple sources and is provided for reference purposes only. It may not be complete or fully applicable to all situations. If you are unable to resolve your issue, please contact the product manufacturer or an authorized service provider for official support.