

Settings and Functions

Hood Operation

Always turn on your hood before you begin cooking to establish airflow in the kitchen. Also let the blower run for a few minutes to clear the air after you turn off your cooking appliance. This will help keep the kitchen air cleaner.

Indoor Hoods

ON/OFF - Blower speed knob — Starts and stops the blower. Push in on the knob to allow it to pop out. Turn the knob clockwise to increase the blower speed and counter clockwise to decrease speed. 0 is off, 1 is lowest speed, and 5 is the highest speed. The type of cooking you are doing will dictate the speed of the blower you use.

Light On/Off / Dimmer knob — Controls the 8-watt LED lights located in the front of the hood. Push in on the knob to allow it to pop out. Turn the knob clockwise to brighten the halogen lights and counter clockwise to dim the lights.. 0 is off, 1 is dimmest and 5 is the brightest.

Heat lamp switches — Push to turn the heat lamps on and off.

Each professional 18" H. wall hood will be equipped with one or two heat lamp outlets. The 250-watt infrared bulbs are not included and should be purchased locally.

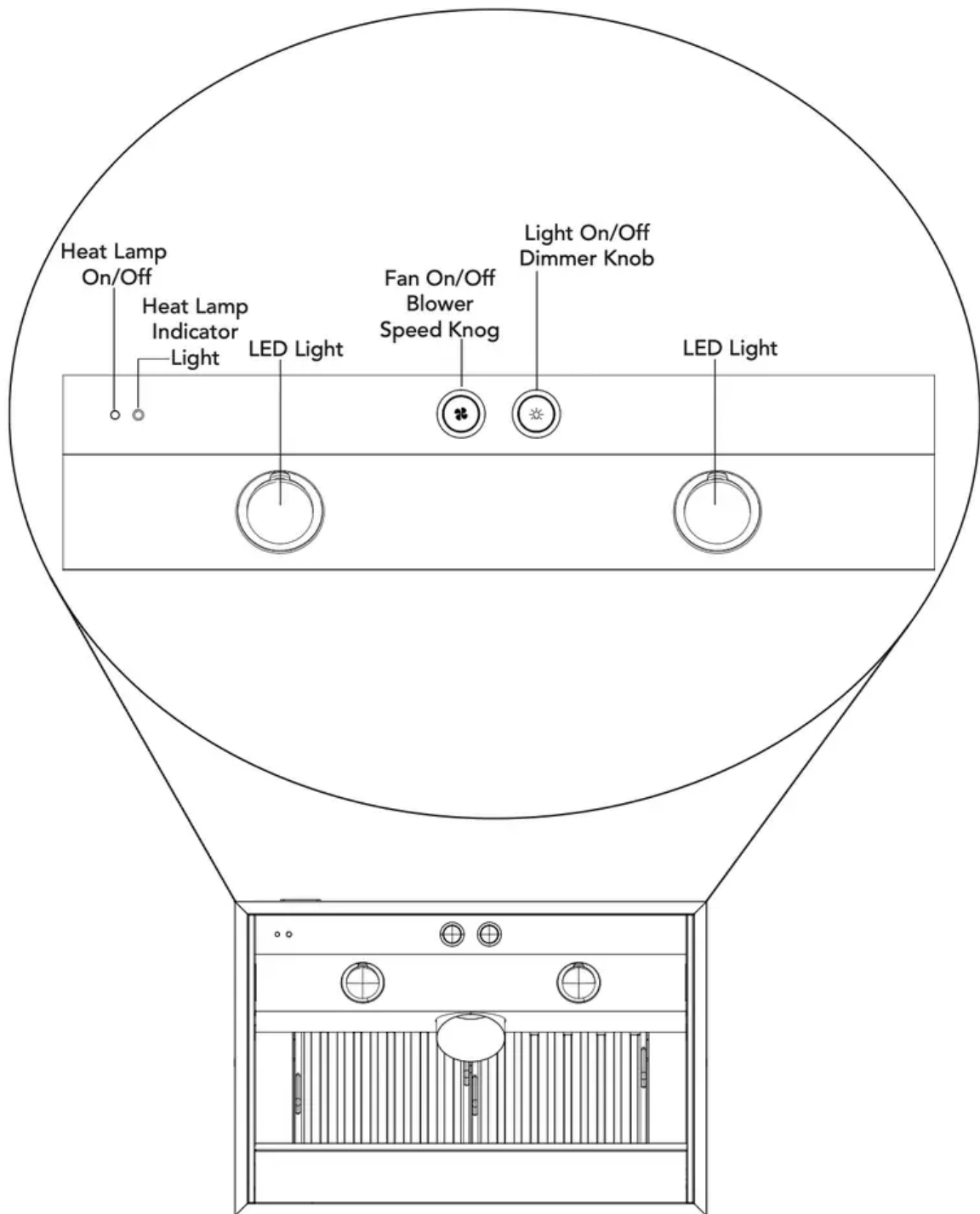

Using Outdoor Hoods

- Outdoor hood models should be installed in a covered yet non-enclosed area. They should also be protected from natural elements (such as rain) as much as possible.
- Always turn the outdoor hood on to the “HIGH” position before lighting the grill.
- Keep the grill canopy closed as much as possible when cooking so smoke is exhausted from the back of the grill. This allows for optimum performance of the hood.

- During breezy conditions, outdoor hoods may not perform well.

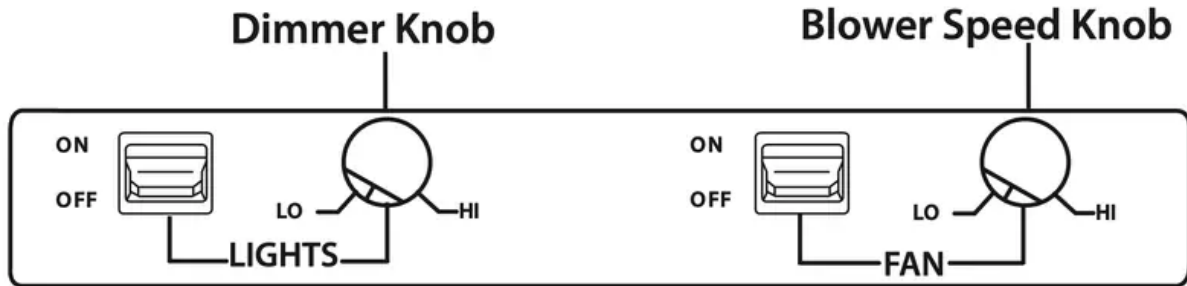

Fan On/Off switch—Starts and stops the blower. When turned on the blower will operate at the previous setting of the speed control.

Blower speed knob—Turn the knob counterclockwise to decrease the blower speed and clockwise to increase speed. The type of cooking you are doing will dictate the speed of the blower you use.

Light switch—Controls the 50-watt halogen lights located in the front of the hood.

Dimmer knob—Turn the knob clockwise to brighten the halogen lights and counterclockwise to dim the lights.

Cleaning and Maintenance

CAUTION: Unplug power cords from control panel before cleaning or servicing hood.

Any piece of equipment works better and lasts longer when maintained properly and kept clean. Ventilation equipment is no exception. Your hood must be kept clean and maintained properly.

Cleaning Baffle Filters

As air passes through a baffle filter, grease particles collect on the stainless steel U-shaped baffle channels and drip down into the bottom of the filter. Baffle filters are extremely efficient when compared to mesh filters. The power of the hood is increased as more air passes through a baffle filter than with mesh filters, which are usually dirty. Baffle filters are almost universally required in commercial installations due to their superior ability to capture grease. The baffle filters should be examined periodically to assure that all surfaces and parts are clean. The filters can be washed in a dishwasher or in a sink with hot, soapy water. Simple periodic cleaning will ensure maximum filter effectiveness.

- Do not use caustic detergent to clean the filters. An abrasive or corrosive cleaner may damage the finish.

- Do not take the baffle filters apart to clean them. It is not necessary and will void the filter warranty.

1. Slide filter forward off of rear lip. Lower filter rear, then slide filter front out.

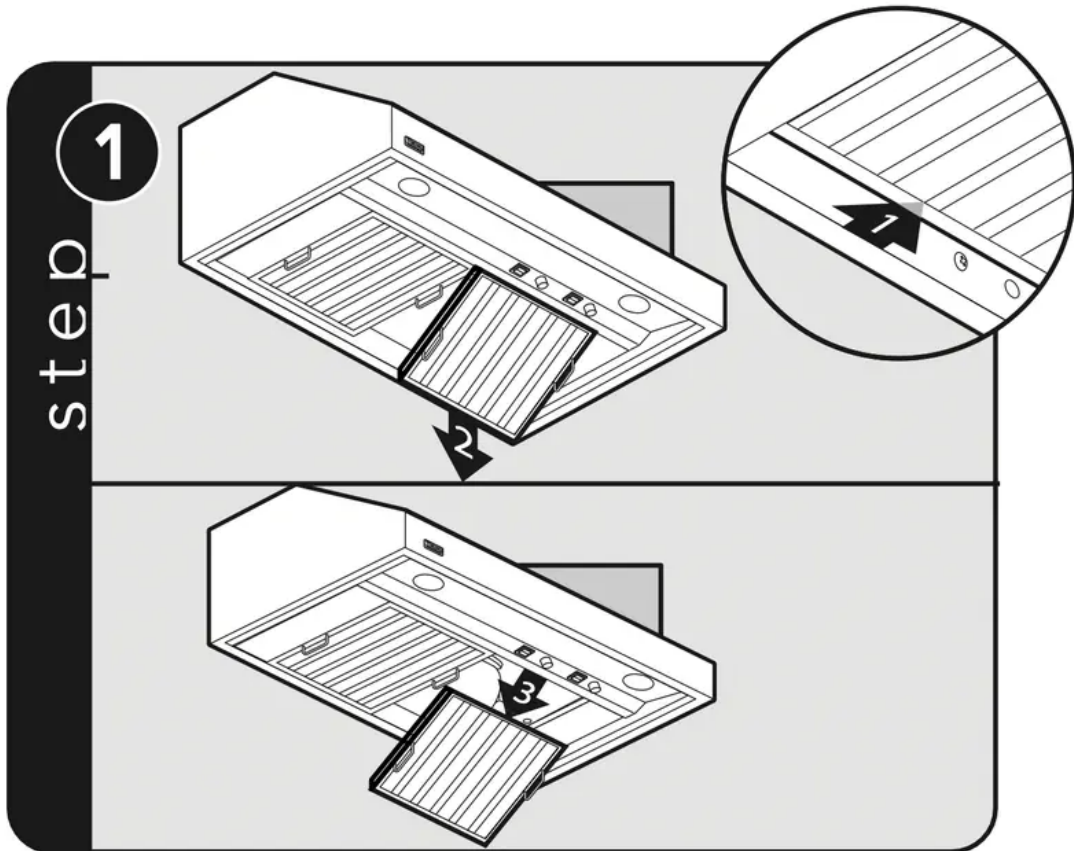

2. Slide filter forward off of rear lip. Lower filter rear, then slide filter front out.

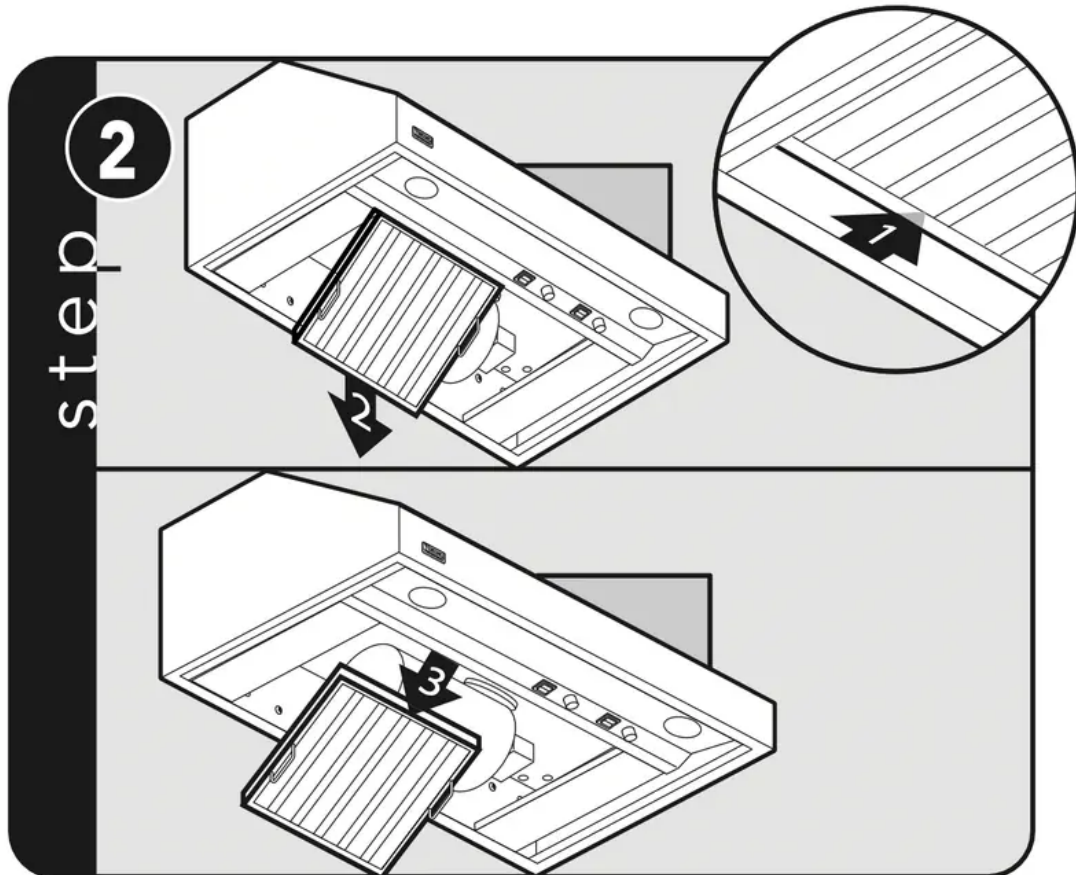

3. Remove the screws located on the side at the top and bottom of each spacer and slide spacer forward off of rear lip. Lower spacer rear, then slide spacer front out.

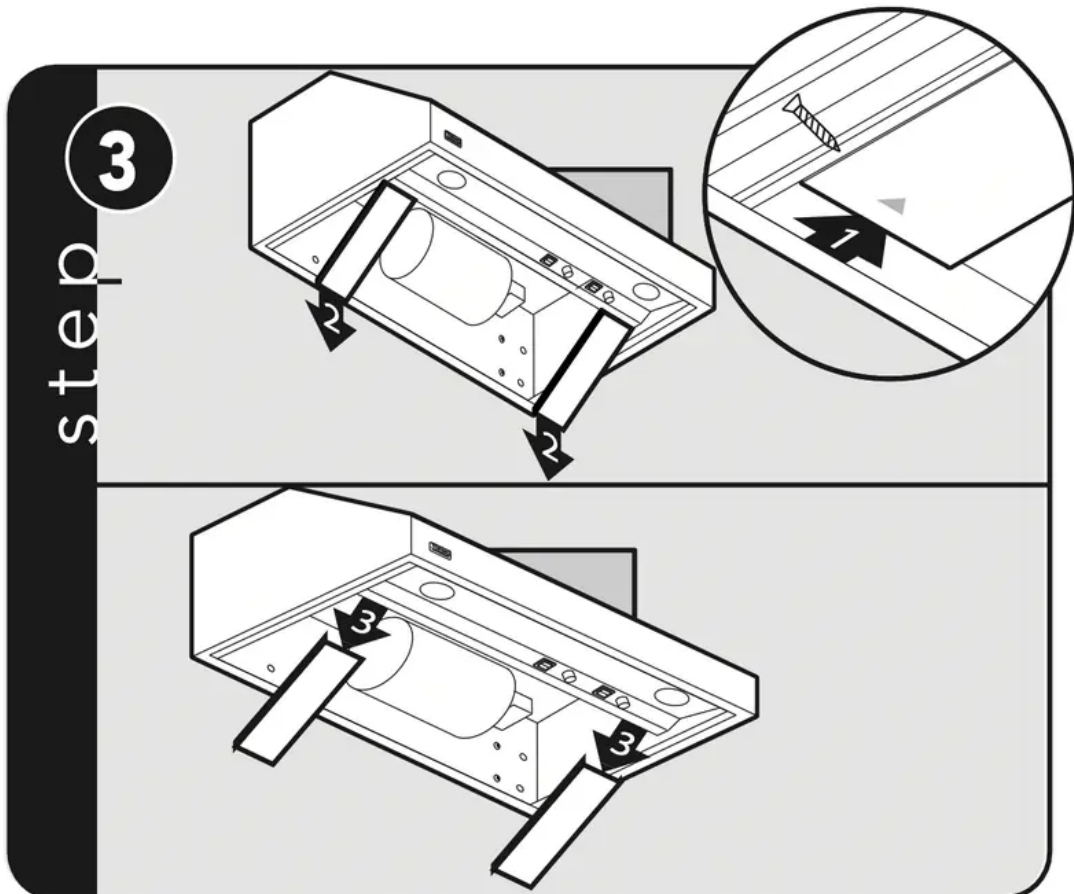

When cleaning filters in 18"H. hoods, always remove the grease trough and clean by



soaking in a sink with hot soapy water.

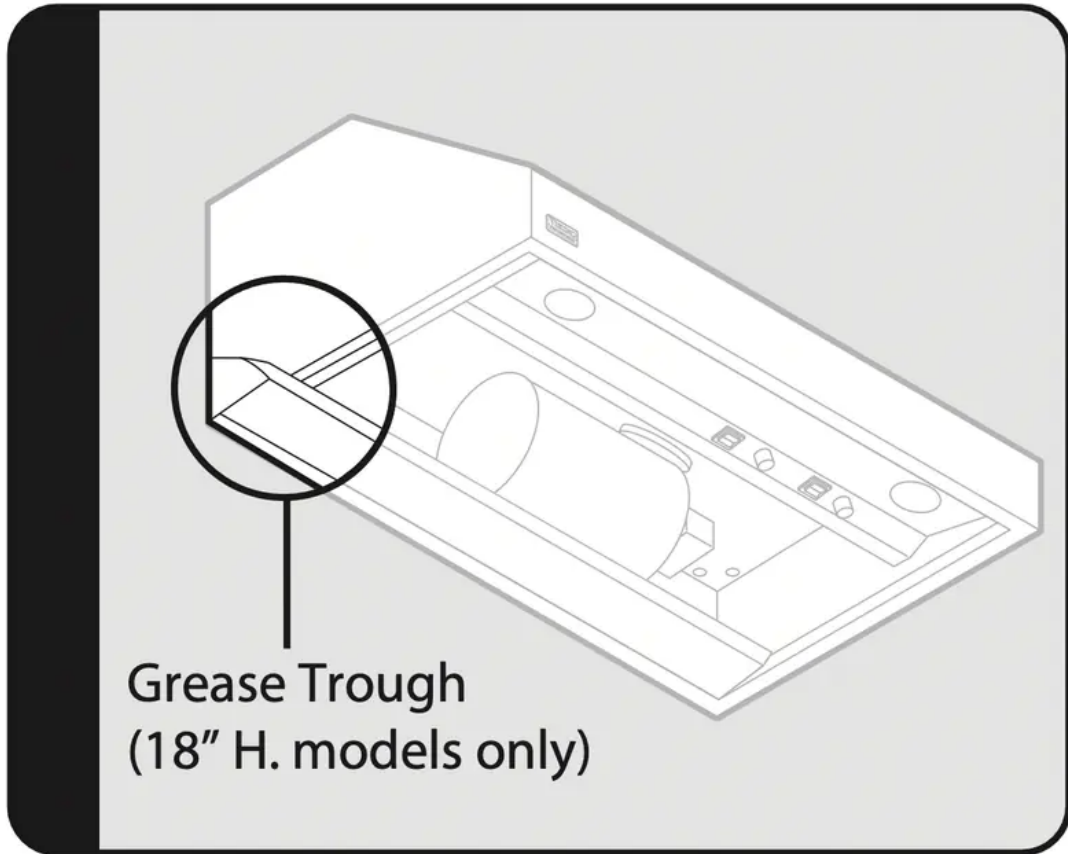

Maintaining Charcoal Filter (Recirculating Hoods Only)

Replace the charcoal filters every 6 months to 1 year depending on the amount and type of cooking you do.

To replace, remove the baffle/charcoal filter assembly and slide the charcoal filter out of the channel and replace with a new one. Do not put the charcoal filters in the dishwasher.

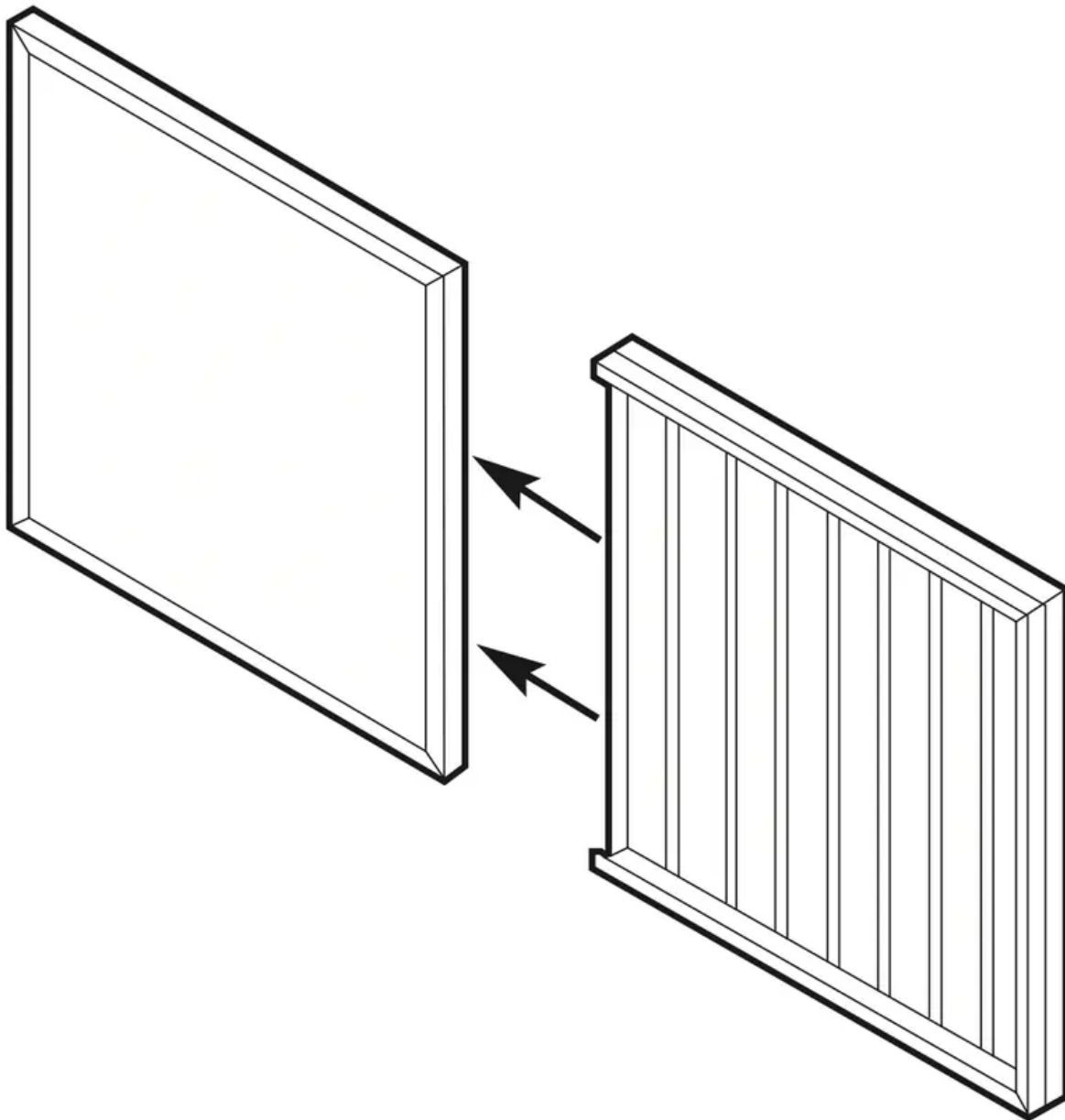

CAUTION: For general ventilating use only. DO NOT use to exhaust hazardous or explosive materials and vapors.

Cleaning Hood Canopy

Finishes in enamel or stainless steel are highly resistant to damage or discoloration due to grease, steam, and heat provided that reasonable care is given to the equipment. The following suggestions will help keep your hood looking new.

1. Do not allow an excessive accumulation of grease. For best results, you should wipe your hood clean with a cloth dipped in warm, soapy water. DO NOT USE ABRASIVE CLEANSERS, STEEL WOOL PADS, OR ABRASIVE CLOTHS. DO NOT use cleansers that contain chlorides; the chlorides in the cleaner could damage the stainless steel finish. If you need to scrape stainless steel to remove encrusted materials, first soak the

area with hot towels to loosen the material, then use a wooden or nylon spatula or scraper. DO NOT use a metal knife, spatula, or any other metal tool to scrape stainless steel.

2. Every 3 months give your hood a thorough cleaning. On painted surfaces, use a new coat of wax. A good wax cleaner available at either a grocery or hardware store—will do both jobs at once. On stainless steel surfaces, use a good stainless steel cleaner and polish.

CAUTION: Do not use a porcelain cleaner or rough abrasive cleaner.

Renewing Enamel Finish

If discoloration occurs, you should thoroughly polish the finish on your hood to renew its gloss and luster and to remove any grease residue which may have a yellowing effect. Use any good enamel polish, refrigerator polish, or automotive polish.

Renewing Stainless Steel Finish

Regular cleaning is the best way to assure that your stainless steel finish stays bright and unscratched. Use lemon oil or stainless steel polish to coat and protect stainless steel.

Cleaning Ductless Venting Chamber (Professional Hoods Only)

1. Remove the middle vent by gently raising up and pulling out.
2. Use the same cleaning directions as in “Cleaning the Hood Canopy” section.
3. After cleaning, replace the middle vent.

Replacing the Light Bulbs

When removing bulbs use an oven mitt to protect your hand in case the bulb breaks.

LED Lights - Indoor Models

1. Unscrew bulb.
2. Replace the bulb with a 120 volt, Phillips R20 8-watt LED bulb (8R20/F90 2700 DIM).
Can be purchased locally.

Halogen Lights - Outdoor Hoods

1. Unscrew halogen bulb.
2. Replace the bulb with a 120 volt, 50-watt halogen bulb.

Infrared Heat Lamp

1. Unscrew infrared bulb from heat lamp socket.
2. Replace the bulb with an R40, 120 volt, 250-watt infrared bulb. (not included with product)

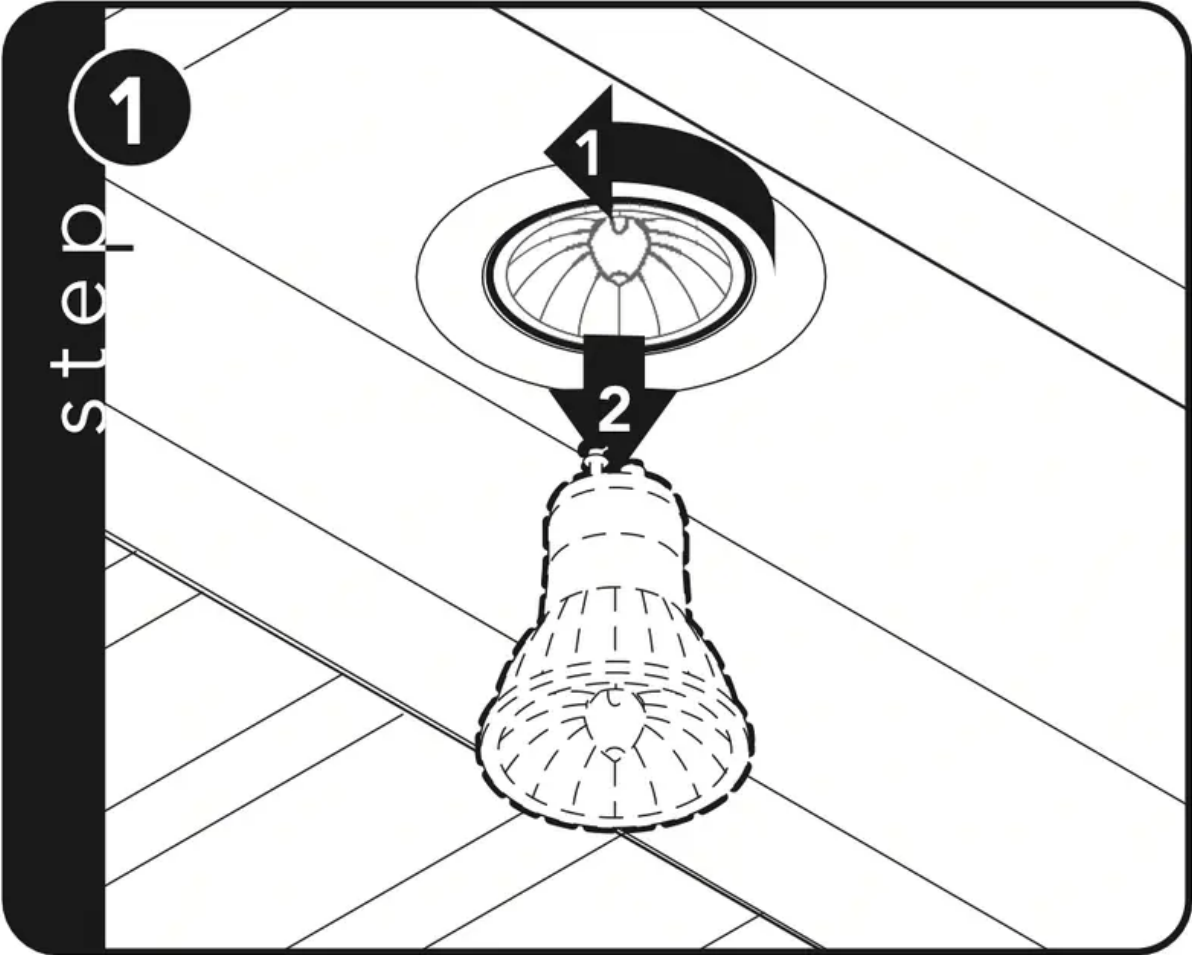

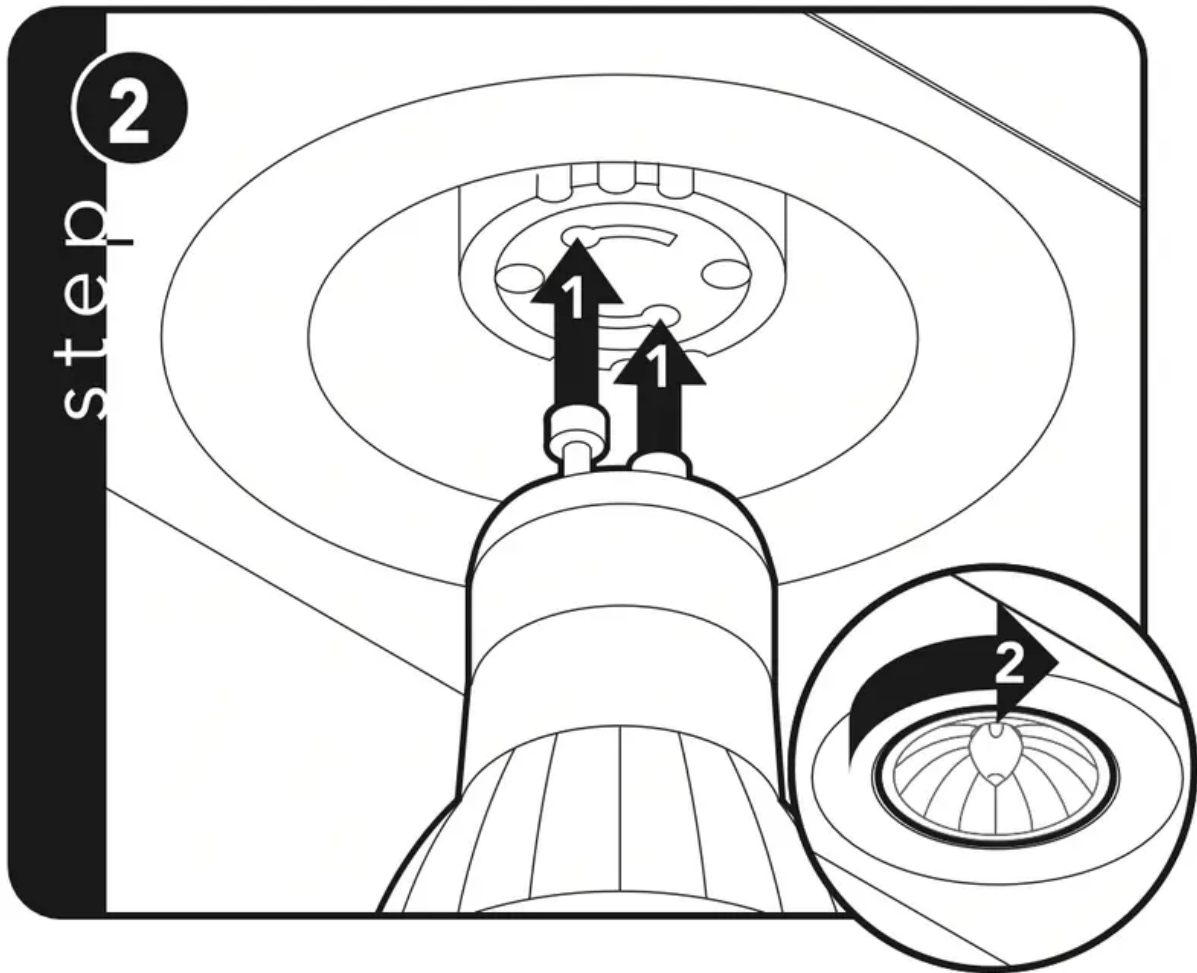

Warning

This content is compiled from multiple sources and is provided for reference purposes only. It may not be complete or fully applicable to all situations. If you are unable to resolve your issue, please contact the product manufacturer or an authorized service provider for official support.

