

## USING THE RANGE

### Surface Units

#### How Induction Surface Cooking Works

The elements beneath the cooking surface produce a magnetic field that generates heat in ferrous metal pans that are in close proximity.

The cooking surface itself does not heat. Heat is produced in the cooking pan, and cannot be generated until a pan is placed on the cooking surface. When the element is activated, the pan begins to heat immediately and in turn heats the contents of the pan.

Magnetic induction cooking requires the use of cookware made of ferrous metals—metals to which magnets will stick, such as iron or steel.

Use pans that fit the element size. The pan must be large enough for the element to detect the pan and be able to deliver full power.

The cooktop will not operate if a very small steel or iron utensil, such as a steel spatula, cooking spoon, knife or other small utensil, is placed on the cooking surface when the unit is turned on.

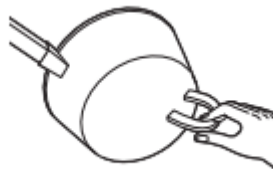

The pan material is correct if a magnet sticks to the bottom.

#### Operating the Cooktop Elements

Before using the cooktop for the first time, clean it with CERAMA BRYTE® Ceramic Cooktop Cleaner. This helps protect the top and makes cleanup easier.

Throughout this manual, features and appearance may vary from your model.

Place your Induction designed cookware on the cooking surface. Push the knob in and turn in either direction to the setting you want.

A knob indicator light will glow when any surface unit is on.

For glass cooktop surfaces:

A HOT COOKTOP indicator light will:

- come on when the unit is hot to the touch.
- stay on even after the unit is turned off.

- stay on until the unit is cooled to approximately 150°F.



At both **OFF** and **HI** the control clicks into position. You may hear slight clicking sounds during cooking, indicating the control is maintaining your desired setting.  
Be sure you turn the control knob to **OFF** when you finish cooking.

### Using the Warming Zone (on some models)

The WARMING ZONE, located in the back center of the glass surface, will keep hot, cooked food at serving temperature. Always start with hot food. Do not use to heat cold food. Placing uncooked or cold food on the WARMING ZONE could result in foodborne illness. To turn the WARMING ZONE on, turn knob clockwise to the setting you want.

For best results, all foods on the WARMING ZONE should be covered with a lid or aluminum foil. When warming pastries or breads, the cover should be vented to allow moisture to escape.

The initial temperature, type and amount of food, type of pan, and the time held will affect the quality of the food.

Always use pot holders or oven mitts when removing food from the WARMING ZONE, since cookware and plates will be hot.

### How To Synchronize Left Elements

NOTE: Sync burners is only intended for cookware that spans both burners.

Knob Operation

1. Ensure both left element knobs are Off.
2. Turn the Sync Knob to desired heat setting.

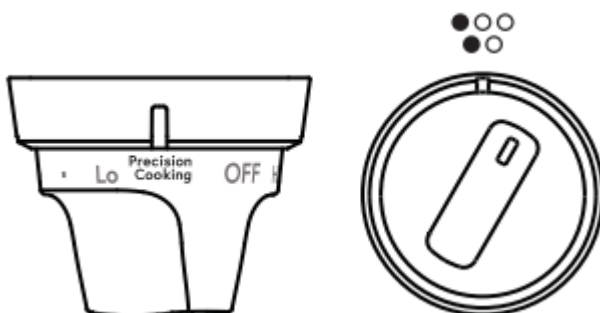

## Precision Cooking

The Precision Cooking feature allows precise temperature control of certain cooking devices for improved results.

### Pairing a Bluetooth® Device

To Activate Wifi refer to Settings section in this Owner's Manual.

Press the Settings pad and select Bluetooth®. Select Pair and activate your device to initiate the device's pairing mode. Refer to the table below for device specific instructions. The range will cancel pairing mode after two minutes if no mating device is detected. Select Remove to confirm product is paired or to un-pair from range.

| Supported Devices  | How to Initiate Pairing                    |
|--------------------|--|
| Hestan Cue fry pan | Firmly double tap the black plastic endcap |
| Hestan Cue pot     | Firmly double tap the black plastic endcap |
| Precision Probe    | Press side button once                     |

### Initiating a Precision Cooking Mode

Turn the knob to Precision Cooking on burner desired for use.

NOTE: Only one burner may run a Precision Cooking mode at a time. If another Precision Cooking mode is attempted, the burner in use for Precision Cooking will flash, and the following error message will be displayed:



Precision Cooking only works on one burner at a time.

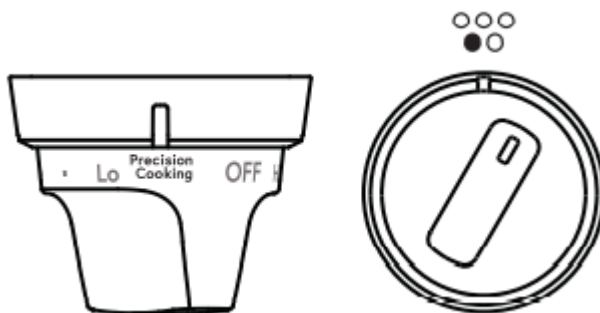

### Activating a Precision Cooking Device

1. The unit must identify which device you intend to use to adjust control parameters appropriately.
2. The display will read "Activate Cookware", instructing you to activate a device to use on the Precision Cooking burner.

Activate cookware

3. Activation instructions for approved devices are listed in the table below.

| Supported Devices  | How to Activate                            | Control with this App                |
|--------------------|--|--------------------------------------|
| Hestan Cue fry pan | Firmly double tap the black plastic endcap | Hestan Cue (by Hestan Smart Cooking) |
| Hestan Cue pot     | Firmly double tap the black plastic endcap | Hestan Cue (by Hestan Smart Cooking) |
| Precision Probe    | Press side button once                     | Café Kitchen (by Café)               |

### Precision Cooking Control Modes

There are two control modes available:

- App Control – the user interacts with an application on a smart phone.
- Local Control – the user interacts with the burner to set a target temperature and no App use is required.

#### App Control

After activating your device on your selected burner, open the App designed to control the selected device. Depending on the device and application, the set temperature may be shown in the unit display, in the App, or hidden from view. NOTE: Use of Local Control mode is blocked upon entering App Control mode.

#### Local Control

After activating your device on your selected burner, rotate the knob to desired temperature. The set temperature will be shown in the display. NOTE: Use of App Control mode is blocked upon entering Local Control mode

Use app or knob to  
set precision cooking  
temp

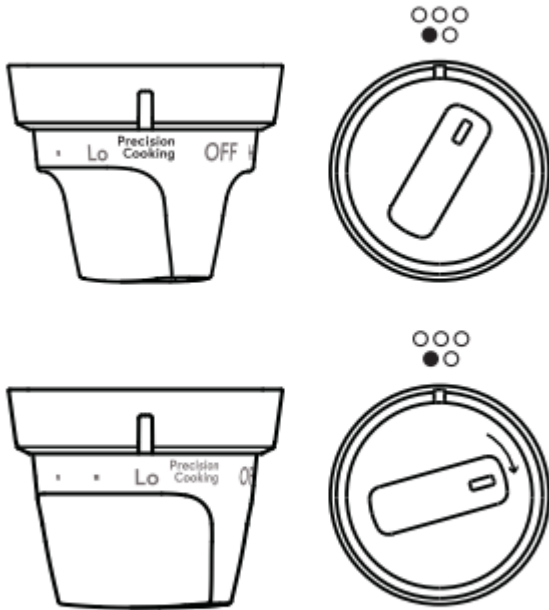

Precision Cooking 175 F

### Precision Cooking – Sync Burners

To start a Precision Cooking mode using the sync burners feature, ensure both left element knobs are Off. Then turn the Sync knob to Precision Cooking. You can now use either App Control or Local Control. For App Control, open the App designed to control the selected device. For Local Control, rotate the Sync Knob to desired temperature. The set temperature will be shown in the display



### App Control

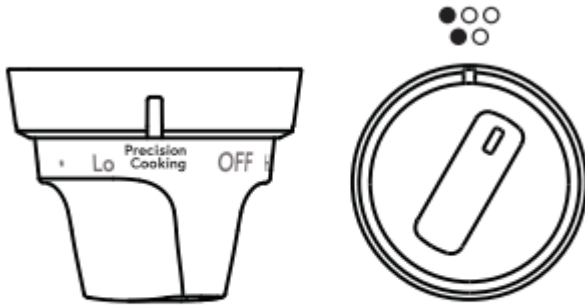

Both left element knobs must be in the OFF position in order to use Sync Burners

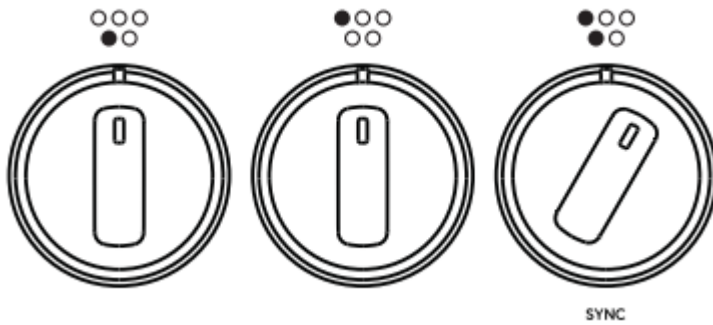

### Local Control

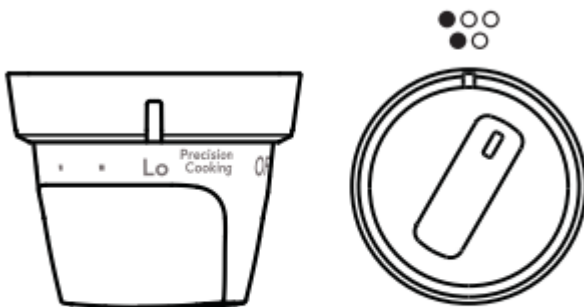

The display will show an error message:



Turn both left knobs  
OFF to use sync  
burners

- If either of the left burners is not at OFF position and sync knob is turned.

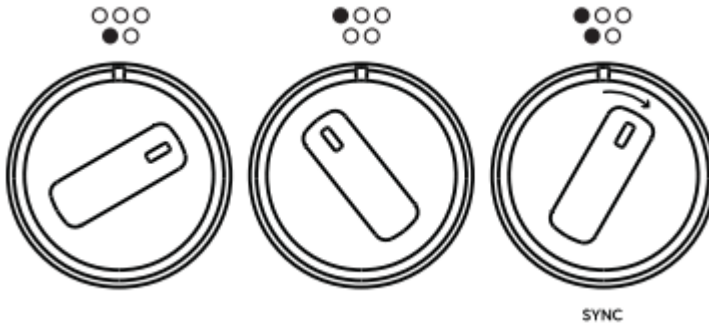

- If sync knob is turned and one of the left burners is moved from the OFF position.

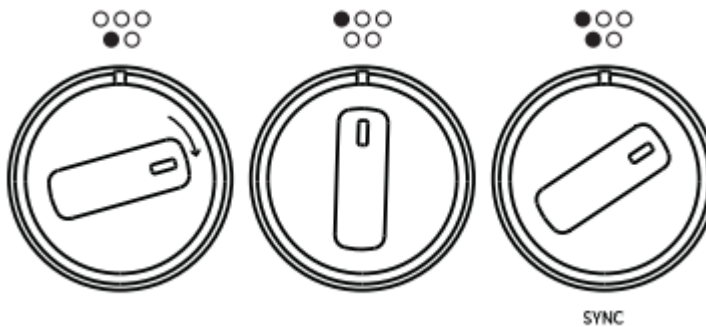

## Oven Controls

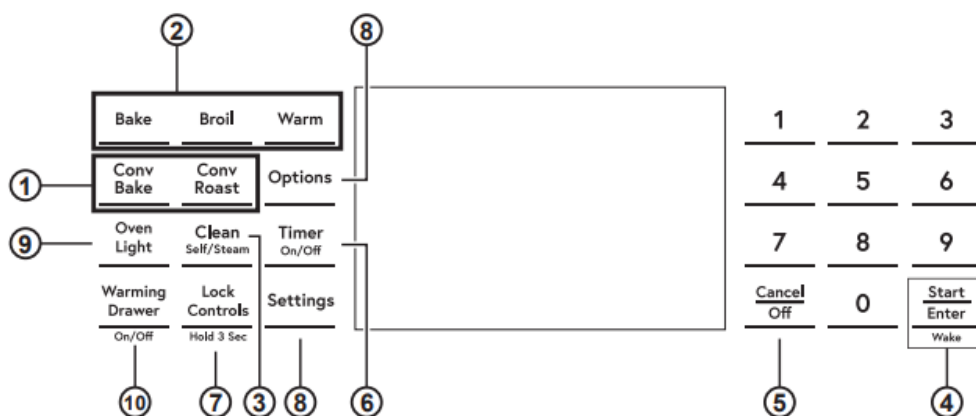

1. Convection Cooking Modes: Convection cooking mode uses increased air circulation to improve performance. See the Cooking Modes section for more information.

2. Traditional Cooking Modes: Your oven has the following traditional cooking modes: Bake and Broil. See the Cooking Modes section for more information.

3. Clean: Your oven has two cleaning modes: Self Clean and Steam Clean. See the Cleaning the Oven section for important information about using these modes.
4. Start/Enter: Must be pressed to start any cooking, cleaning, or timed function.
5. Cancel/Off: Cancels ALL oven operations except the clock, timer and warming drawer.
6. Timer: Works as a countdown timer. Press the Timer pad and use the number pads to program the time in hours and minutes. Press the Start/Enter pad. The oven will continue to operate when the timer countdown is complete. To turn the timer off, press the Timer pad.
7. Lock Controls: Locks out the control so that pressing the pads does not activate the controls. Press the Lock Controls pad, for three seconds to lock or unlock the control. Cancel/Off is always active, even when the control is locked.
8. Options and Settings: The Options and Settings pads open up more detailed menus in the display that allow access to additional functions and cooking modes. For each you select the function in the display using the associated number pad. You can exit at any time by pressing the Options or Settings pad again. See the Settings, Options, and Cooking Modes Sections for more details.
9. Oven Light: Turns the oven light on or off.
10. Warming Drawer: Will keep hot, cooked foods at serving temperature. See the Cooking Modes section for more information.

## **Options**

The options pad opens up a menu of more cooking modes when the oven is off. It opens a menu with additional features if a cooking mode is already in process. You can exit the menu at any time by pressing the Options pad again. You must first select a mode (bake, convection bake, convection roast) and then select Options to get to the following functions.

### **Cook Time**

Counts down cooking time and turns off the oven when the cooking time is complete. Select a desired cooking mode. Use the number pads to program a baking temperature. Press the Options pad and select Cook Time. Use the number pad to program cook time in hours and minutes. Then press Start/Enter. This can only be used with Bake, Convection Bake, and Convection Roast.

### **Delay Time**

Delays when the oven will turn on. Use this to set a time when you want the oven to start. Select a desired cooking mode. Use the number pad to program a baking temperature. Press the Options pad and select Delay Time. Use the number pads to program the time of day for the oven to turn on, and then press Start/Enter. Delay Time is not available with all modes.

NOTE: When using the Delay Time feature, foods that spoil easily – such as milk, eggs, fish, stuffing, poultry, and port – should not be allowed to sit for more than 1 hour before or after

cooking. Room temperature promotes the growth of harmful bacteria. Be sure that the oven light is off because heat from the bulb will speed harmful bacteria growth.

### **Oven Probe**

NOTE: Only accessible through traditional and convection cooking modes.

Monitors internal food temperature and turns the oven off when the food reaches the programmed temperature. Insert the probe, press the desired cooking mode, and program the probe temperature. See the Cooking Modes Section for more information. The probe can only be used with Bake, Convection Bake, and Convection Roast.

### **Settings**

The Options and Settings pads open up more detailed menus in the display that allow access to additional functions. For each you select the function in the display using the associated number pad. You can exit at any time by pressing the Options or Settings pad again.

### **WiFi Connect and Remote Enable**

Your oven is designed to provide you with two-way communication between your appliance and smart device. By using the WiFi Connect features, you will be able to control essential oven operations such as temperature settings, timers and cooking modes using your smartphone or tablet."

Select Settings then Wifi - follow the instructions on your oven display and phone app. It is necessary to turn on WiFi before using Remote Enable on your oven.

### **Connecting your WiFi Connect Enabled Oven**

What you will need

Your GE Appliances oven uses your existing home WiFi network to communicate between the appliance and your smart device. In order to setup your GE Appliances oven, you will need to gather some information:

1. Each GE Appliances oven has a connected appliance information label that includes an Appliance Network Name and Password. These are the two important details that you will need to connect to the appliance. The label is typically located inside the door of the oven or drawer.
2. Have your smart phone or tablet ready with the ability to access the internet and download apps.
3. You will need to know the password of your home WiFi router. Have this password ready while you are setting up your GE Appliances oven.

Connected Appliance Information

FCC: ZKJ-WCATA001

IC: 10229A-WCATA001

MAC ID:XX-XX-XX-XX-XX-XX



Network: GE\_XXXXX\_XXXX

Password: XXXXXXXX

PT. NO. 229C6272G001-0

Sample Label

### **Connect your Café oven**

1. On your smart phone to learn more about connected appliance features and to download the appropriate app.
2. Follow the app onscreen instructions to connect your GE Appliances oven.
3. Once the process is complete, the connection light located on your GE Appliances oven display will stay on solid and the app will confirm you are connected.
4. If the connection light does not turn on or is blinking, follow the instructions on the app to reconnect. If issues continue, please call the Connected Call Center 1.866.626.2000 and ask for assistance regarding oven wireless connectivity.

To connect additional smart devices, repeat steps 1 and 2.

Note that any changes or modifications to the remote enable device installed on this oven that are not expressly approved by the manufacturer could void the user's authority to operate the equipment.

### **REMOTE STARTING YOUR OVEN**

To be able to start the oven remotely once connected to WiFi, press the Remote Enable pad and the icon will turn on in the display. The oven can now be remotely started with a connected device. Opening an oven door or turning off the oven will turn off the icon. The icon must be lit to start the oven remotely. The icon is not required to change the oven temperature while it is running, set a timer or to turn the oven off from the phone app while the icon shows it is Wifi Connected.

After using the oven, remember to verify that the icon is lit if you wish to start the oven remotely in the future.

NOTE: Foods that spoil easily-such as milk, eggs, fish, stuffings, poultry and pork-should not be allowed to sit for more than 1 hour before or after cooking. Room temperature promotes the growth of harmful bacteria. Be sure that the oven light is off because heat from the bulb will speed harmful bacteria growth.

### **Clock**

This setting sets the oven clock time. Press the Settings pad and select Clock. Select Set Clock and follow the instructions to set the clock. This feature also specifies how the time of day will be displayed. You can select a standard 12-hour clock (12H), 24-hour military time display (24H), or no clock displayed (Off). Press the Settings pad, select Set Clock and select either 12/24 hr or On/Off.



## **Bluetooth® - Chef Connect**

This is a pairing feature for use with other compatible Chef Connect enabled products like an over-the range microwave oven or range hood. To pair those products to the range Press the Settings pad and select Bluetooth®. Select Pair and follow the corresponding instructions included with the mating Chef Connect enabled product. The range will cancel pairing mode after two minutes if no mating device is detected. Select

Remove to confirm product is paired or to un-pair from range. The Precision Cooking Probe can also be paired using the Bluetooth® feature.

## **Auto Conv (Auto Conversion)**

When using Convection Bake and Convection Roast cooking, Auto Recipe Conversion will automatically convert the regular baking temperatures entered to convection bake cooking temperatures when turned on. Note that this option does not convert convection bake cooking times, it only converts temperatures. This feature may be turned On or Off. Select Settings, Auto Conversion is 5th option and shows up on first display of settings, and Auto Conversion then follow the prompts to turn this feature on or off.

## **Auto Off**

This feature shuts the oven down after 12 hours of continuous operation. It may be enabled or disabled. Select Settings, More, and Auto Off to turn this feature on or off.

## **Sound**

You can adjust the volume and type of alert your appliance uses. Select Settings, More, and Sound. Follow prompts for making volume adjustments or for changing between continuous and single alert tones. A continuous setting will continue to sound a tone until a button on the control is pressed. The oven tone volume can be adjusted. The control will sound the oven tone at the new volume level each time the sound level is changed.

## **F/C (Fahrenheit or Celsius)**

The oven control is set to use Fahrenheit temperatures (F), but you can change it to use Celsius temperatures (C). Select Settings, More, and F/C to alter between temperature scales displayed.

## **Adjust the Oven temperature**

**This feature allows the oven baking and convection baking temperature to be adjusted up to 35°F hotter or down to 35°F cooler.** Use this feature if you believe your oven temperature is too hot or too cold and wish to change it. This adjustment affects Bake and Convection Bake modes. Does not change Proof or Cleaning modes. Select Settings and Oven Adjust to add More Heat or Less Heat and then press Save.

## **Oven Info**

Select Settings, More, and Oven Info to turn this feature on or off. This setting displays Model Number and Software Version

## Sabbath Mode

The Sabbath mode feature complies with standards set forth by Star K. Some of these standards that will be noticed by the consumer include the disabling of tones, disabling of oven lights, and delays of about 30 seconds to one minute on display changes. Only continuous baking or timed baking is allowed in the Sabbath mode. Cooking in the Sabbath mode is a two-step process, first the Sabbath mode must be set and then the bake mode must be set.

### Setting the Sabbath Mode

1. Press and hold Bake + Broil to enter special features menu.
2. Use number key 8 to navigate to "Sabb" menu, Enter the menu using number key 6.
3. Use number key 8 again to toggle the setting to ON. Use number key 6 to confirm the setting.
4. Use number key 4 to exit Special features menu.
5. A single left opening bracket will appear.

### Starting a Continuous Bake

1. Press the Bake pad. (For double ovens, this operates the upper oven. If desiring to use Lower Oven, press Lower Oven and then Bake. )
2. If the desired temperature is 350F, press Start/Enter. If a different cooking temperature is desired, use the 1 through 5 number pads to select a preset cooking temperature, then press Start/Enter. Refer to the graphic below to determine which pad sets the desired cooking temperature.

After a delay, a second bracket "]" will appear in the display indicating that the oven is baking.

|                  |                             |          |   |
|------------------|-----------------------------|----------|---|
| Temperature (°F) | <b>1</b>                    | <b>2</b> | <b>3</b>                                    |
|                  | 200                         | 250      | 300   |
| Time (hours)     | <b>4</b>                    | <b>5</b> | <b>6</b>                                    |
|                  | 325                         | 400      | 2h  |
|                  | <b>7</b>                    | <b>8</b> | <b>9</b>                                    |
|                  | 2.5h                        | 3h       | 3.5h  |
|                  | <b>Cancel</b><br><b>Off</b> | <b>0</b> | <b>Start</b><br><b>Enter</b><br><b>Wake</b> |
|                  |                             | 4h       |   |

1 = 200° F, 2 = 250° F, 3 = 300° F, 4 = 325° F, 5 = 400° F

6 = 2 hours, 7 = 2.5 hours, 8 = 3 hours, 9 = 3.5 hours, 0 = 4 hours

## Adjusting the Temperature

1. Press Bake or press Lower Oven and then Bake for lower oven in a double oven unit), use the 1 through number pads to select a different preset cooking temperature, and press Start/Enter.
2. Since no feedback is given during temperature change, an oven thermometer can be used to confirm temperature changes.

## Starting a Timed Bake

1. Press the Bake pad.
2. If the desired temperature is 350F, use the 6 through 0 number pads to select a cooking time. If a cooking temperature other than 350F is desired, use the 1 through 5 number pads to select a preset cooking temperature, then select the cooking time. Refer to the graphic on this page to determine which pad sets the desired cooking temperature and cooking time.
3. Press Start/Enter.

After a delay, a second bracket “[” [“ will appear in the display indicating that the oven is baking. When the cook time expires, the display will change back to a single bracket “]” indicating that the oven is no longer baking. No tone will sound when the cook time is complete.

## Exit the Sabbath Mode

Exiting the Sabbath mode should be done after the Sabbath is over.

1. Press Cancel/Off to end any bake mode that may be running.
2. Press and hold Settings pad until Sabbath Mode off is displayed.

## Sabbath Mode Power Outage Note

If a power outage occurs while the oven is in Sabbath Mode, the unit will return to Sabbath Mode when power is restored, however the oven will return to the off state even if it was in the middle of a bake cycle when the power outage occurred

## Oven Racks

Recommended rack positions for various types of foods are provided in the Cooking Guide. Adjusting rack position is one way to impact cooking results. For example, if you would prefer darker tops on cakes, muffins, or cookies, try moving food one rack position higher. If you find foods are too brown on top try moving them down next time.

When baking with multiple pans and on multiple racks, ensure there is at least 1½" between pans to allow sufficient space for air to flow.

To avoid possible burns, place the racks in the desired position before you turn the oven on.

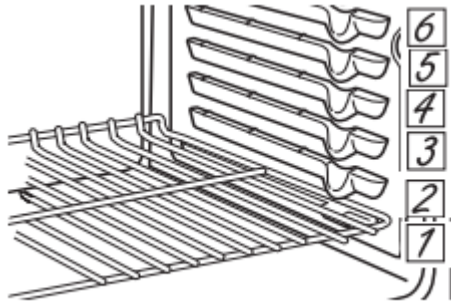

The number of rack positions may vary by model.

## Extension Racks

Always pull the rack out by its upper front rail to its fully open position, when placing or removing cookware.

If extension racks are difficult to extend, lubricate the racks with the graphite lubricant provided with your oven. Remove the rack from the oven, remove debris in the side tracks with a paper towel, shake the graphite lubricant and place 4 small drops on the two bottom tracks of the left and right sides. Open and close the rack several times to distribute the lubricant.

To order additional graphite lubricant, see the Accessories and Consumer Support sections at the end of this manual.

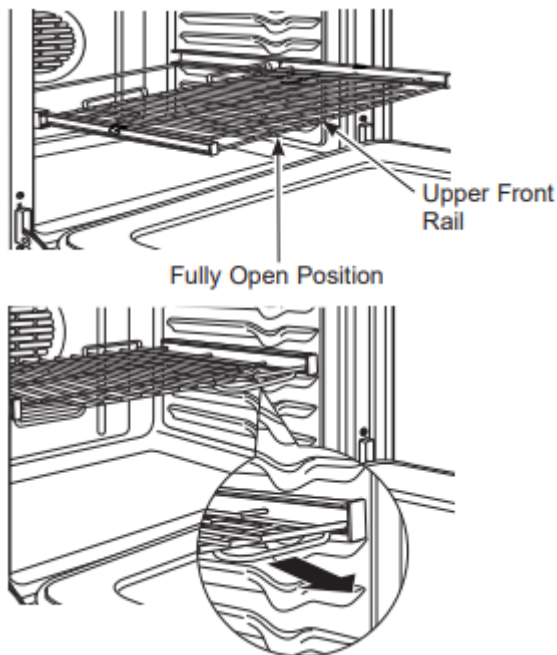

## To Remove An Extension Rack:

1. Make sure the rack is pushed all the way into the oven so that side paddles on the rack disengage from the oven support.
2. Slide the rack toward you to the bump (stop position) on the rack support.

3. Firmly grasp both sides of the rack frame and the sliding rack, tilt the front end up and pull it out.

#### To Replace An Extension Rack:

1. Firmly grasp both sides of the rack frame and the sliding rack.
2. Place the curved end of the rack (stop-locks) onto the oven supports, tilt up the front of the rack and push it in as far as it will go.

If extension racks are difficult to replace or remove, wipe the oven rack supports with vegetable oil. Do not wipe oil on the rack slides.

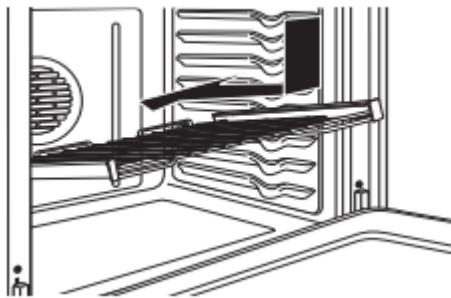
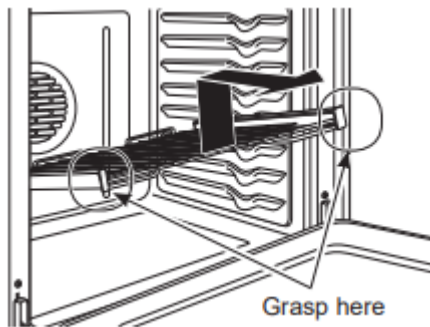

#### To Lubricate the Paddle:

Shake lubricant and apply to the moving parts of the paddle mechanisms as shown.

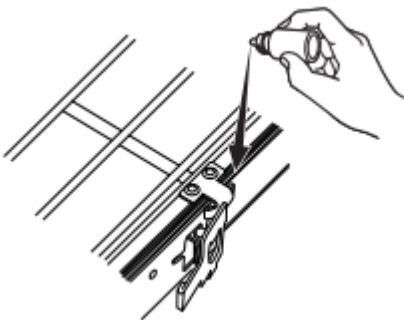

#### Aluminum Foil and Oven Liners

Foil may be used to catch spills by placing a sheet on a lower rack, several inches below the food. Do not use more foil than necessary and never entirely cover an oven rack with aluminum foil. Keep foil at least 1-1/2" from oven walls to prevent poor heat circulation

## **Cookware**

### **Cookware Guidelines**

The material, finish, and size of cookware affect baking performance.

Dark, coated and dull pans absorb heat more readily than light, shiny pans. Pans that absorb heat more readily can result in a browner, crisper, and thicker crust. If using dark and coated cookware check food earlier than minimum cook time. If undesirable results are obtained with this type of cookware consider reducing oven temperature by 25°F next time.

Shiny pans can produce more evenly cooked baked goods such as cakes and cookies.

Glass and ceramic pans heat slowly but retain heat well. These types of pans work well for dishes such as pies and custards.

Air insulated pans heat slowly and can reduce bottom browning.

Keep cookware clean to promote even heating.

### **Oven Cooking Modes**

#### **Bake**

The traditional bake mode is intended for single rack cooking. This mode uses heat primarily from the lower element but also from the upper element to cook food.

Preheating is generally recommended when using this mode. To use this mode press the Bake pad, enter a temperature with the number pads, and then press Start.

#### **Broiling Modes**

Always broil with the door closed. The broil element in this oven is very powerful. Monitor food closely while broiling. Use caution when broiling; placing food close to the broil element or burner increases smoking, spattering and the possibility of fats igniting. It is not necessary to preheat when using the Broil modes.

#### **Warm**

Warm mode is designed to keep hot foods at a higher temperature for up to 3 hours. Preheating is not required. Do not use warm to heat cold food other than crisping crackers, chips, or dry cereal. It is also recommended that food not be kept warm for more than 2 hours. Press the Warm pad and then press Star/Enter. Some models may also have warming drawers. Three settings are available - use High for items such as stews, meats, and potatoes; use Medium for items such as casseroles and pizzas; use Low for items such as breads, waffles, and also for warming oven-safe dishes.

#### **Broil Hi**

The Broil Hi mode uses intense heat from the upper element to sear foods. Use Broil Hi for thinner cuts surface and rare interior. To use this mode press the Broil pad once and then press Start.

## **Broil Lo**

The Broil Lo mode uses less intense heat from the upper element to cook food thoroughly while also browning the surface. Use Broil Lo thicker cuts of meat and/or foods that you would like cooked all the way through. To use this mode press the Broil pad twice and then press Start/Enter.

## **Frozen Snacks**

The Frozen Snacks modes are designed to cook frozen foods such as potato nuggets, French fries, and similar frozen snacks and appetizers. Most foods will cook within package recommended time. Adjust cooking time according to individual preferences.

Use Frozen Snacks Single when cooking frozen snacks on a single rack. This mode does not require preheating the oven. Food should be placed in the oven before or immediately upon starting this mode.

Use Frozen Snacks Multi when cooking frozen snacks on two racks simultaneously. This mode includes a preheating cycle to prepare the oven for multi-rack baking. Press Options and select Frozen then follow any display prompts to access this mode.

## **Frozen Pizza**

The Frozen Pizza modes are designed to cook frozen pizzas. Most pizzas will cook within package recommended times. Adjust cooking time according to individual preferences.

Use Frozen Pizza Single when cooking on a single rack.

This mode does not require preheating the oven. Food should be placed in the oven before or immediately upon starting this mode.

Use Frozen Pizza Multi when cooking on two racks simultaneously. This mode includes a preheating cycle to prepare the oven for multi-rack baking. Press Options and select Frozen then follow any display prompts to access this mode.

## **Baked Goods**

The Baked Goods mode is designed for cooking cakes, breads, cookies, and similar foods on a single rack. This mode is designed to provide lighter top browning and better volume. Some foods may require slightly longer cook times relative to when cooked in the traditional bake mode. Press Options and select Baked Goods then follow any display prompts to access this mode.

## **Convection Bake Multi Rack**

The Convection Bake mode is intended for baking on multiple racks at the same time. This mode uses air movement from the convection fan to enhance cooking evenness. Your oven is equipped with Auto Recipe Conversion, so it is not necessary to adjust the temperature when using this mode. Always preheat when using this mode. Baking times may be slightly longer for multiple racks than what would be expected for a single rack. To use this mode press the Conv Bake pad, enter a temperature with number pads, and then press Start/Enter.

## **Convection Roast**

The Convection Roast mode is intended for roasting whole cuts of meat on a single rack. This mode uses air movement from the convection fan to improve browning and reduce cooking time. Check food earlier than the recipe suggested time when using this mode, or use the probe (see the Probe section for more information). It is not necessary to preheat when using this mode. To use this mode press the Conv Roast pad, enter a temperature with the number pads, and then press Start/Enter.

## **Proof**

Proof mode maintains a warm environment for rising yeast-leavened dough. If the oven is too warm, Proof mode will not operate and the display will show "Oven too hot for Proof". For best results, cover the dough while proofing and check early to avoid over-proofing.

## **Oven Probe**

Internal food temperature is frequently used as an indicator of doneness, especially for roasts and poultry. The Probe mode monitors the internal food temperature and turns the oven off when the internal food temperature reaches the programmed temperature.

Always check the temperature at multiple locations in the food with a food thermometer after cooking to ensure that all portions of the food have reached the minimum safe internal temperature for that food.

## **Proper Probe Placement**

After preparing the meat and placing it on the cooking pan follow these guidelines for proper probe placement.

- Insert the probe completely into the meat, up to the handle, such that the point of the probe will rest in the center of the thickest part of the meat.
- The probe should not touch bone, fat or gristle.
- For whole poultry insert the probe into the thickest part of the breast.
- For bone less roasts, insert the probe into the center of the roast.
- For bone-in ham or lamb, insert the probe into the center of the lowest large muscle or joint.
- For casseroles or dishes such as meatloaf, insert the probe into the center of the dish.
- For fish, insert the probe from just above the gill into the meatiest area, parallel to the backbone.

Check the temperature at other locations in the food with a food thermometer once the probe temperature is reached to ensure that all portions of the food have reached desired temperatures.

## **Probe Usage**

The temperature probe can only be used with Bake,

Convection Bake, and Convection Roast.

To use the probe with preheating:

1. Select the desired cook mode (Bake, Convection Bake, or Convection Roast) pad and enter the desired cooking temperature with the number pads.
2. Insert the probe into the food (see Proper Probe Placement).
3. Once the oven is preheated, place the food in the oven and connect the probe to the probe outlet, making sure it is fully inserted. Use caution, the oven walls and probe outlet are hot.
4. When the probe is connected, the display will prompt you to enter the desired food temperature. The maximum internal food temperature that you can set is 200° F.

To use the probe without preheating:

1. Insert the probe into the food (see Proper Probe Placement).
2. Place the food in the oven and connect the probe into the probe outlet in the oven.
3. Press the Cook Mode pad (Traditional Bake, Convection Bake, or Convection Roast) and enter the desired cooking temperature with the number pads. Press Options and select Probe then follow the display prompts to enter the desired food temperature.

### **Probe Care Guidelines**

- Use of probes other than the one provided with this product may result in damage to the probe.
- Use the handles of the probe and plus when inserting and removing them from the meat and outlet
- To avoid damaging your probe, do not use tongs to pull on the cable when removing it.
- To avoid breaking the probe, make sure food is completely defrosted before inserting the probe.
- To prevent possible burns, do not unplug the probe from the outlet until the oven has cooled.
- Never leave the probe inside the oven during s self or steam clean cycle.
- Do not store the probe in the oven.

# Cooking Guide

| FOOD TYPE   | RECOMMENDED MODE(S)      | RECOMMENDED RACK POSITION(S)                | ADDITIONAL SUGGESTIONS  |
|---|--------------------------|---|---|
| <b>Baked Goods</b>  |                          |   |   |
| Layer cakes, sheet cakes, bundt cakes, muffins, quick breads on a Single Rack | Bake<br>Bake Goods       | 3   | Use shiny cookware.   |
| Layer cakes* on Multiple Racks  | Bake<br>Convection Bake  | 2 ext and 5 flat                            | Use shiny cookware. Ensure adequate airflow (see illustration below).   |
| Chiffon cakes (angel food)  | Bake<br>Bake Goods       | 1   | Use shiny cookware.   |
| Cookies, biscuits, scones on a Single Rack                                    | Bake<br>Bake Goods       | 3   | Use shiny cookware.   |
| Cookies, biscuits, scones on Multiple Racks                                   | Convection Bake          | 2 ext and 5 flat<br>1 flat, 3 flat, 5 ext   | Use shiny cookware. Ensure adequate airflow.  |
| Yeast Breads  | Proof                    | 2 or 3                                      | Cover dough loosely.  |
|   | Bake<br>Bake Goods       | 3   |   |
| <b>Beef &amp; Pork</b>  |                          |   |   |
| Hamburgers  | Broil High               | 6 flat                                      | Use a broil pan; move food down for more doneness/less searing. Watch food closely when broiling. For best performance center food below the broil heater.                                  |
| Steaks & Chops  | Broil High               | 6 flat or 5 ext                             | Use a broil pan; move food down for more doneness/less searing. Watch food closely when broiling. For best performance center food below the broil heater.                                  |
| Roasts  | Bake<br>Convection Roast | 2 or 3                                      | Use a low sided pan such as a broil pan. Preheating is not necessary.   |
| <b>Poultry</b>  |                          |   |   |
| Whole chicken   | Bake<br>Convection Roast | 2 or 3                                      | Use a low sided pan such as a broil pan. Preheating is not necessary.   |
| Bone-in chicken breasts, legs, thighs   | Broil Low<br>Bake        | 3   | If breaded or coated in sauce avoid Broil High modes. Broil skin side down first. Watch food closely when broiling. For best performance when broiling, center food below the broil heater. |
| Boneless chicken breasts  | Broil Low<br>Bake        | 3   | Move food down for more doneness/less searing and up for greater searing/browning when broiling. For best performance when broiling, center food below the broil element or burner.         |
| Whole turkey  | Bake<br>Convection Roast | 1   | Use a low sided pan such as a broil pan. Preheating is not necessary.   |
| Turkey Breast   | Bake<br>Convection Roast | 3   | Use a low sided pan such as a broil pan. Preheating is not necessary.   |
| Fish  | Broil Low                | 6 (1/2 inch thick or less)<br>5 (>1/2 inch) | Watch food closely when broiling. For best performance center food below the broil heater.  |
| Casseroles  | Bake                     | 3 or 4                                      |   |
| <b>Frozen Convenience Foods</b>   |                          |   |   |
| Pizza on a Single Rack  | Frozen Pizza Single      | 3   | Place food in oven prior to starting mode.  |
| Pizza on Multiple Racks   | Frozen Pizza Multi       | 2 ext and 5 flat                            | Stagger pizzas left to right, do not place directly over each other.  |
| Potato products, chicken nuggets, appetizers on a Single Rack                 | Frozen Snacks Single     | 4 or 5                                      | Place food in oven prior to starting mode. Use dark cookware for more browning/crisping; use shiny cookware for less browning.  |
| Potato products, chicken nuggets, appetizers on Multiple Racks                | Frozen Snacks Multi      | 2 ext and 5 flat                            | Use dark cookware for more browning/crisping; use shiny cookware for less browning.   |

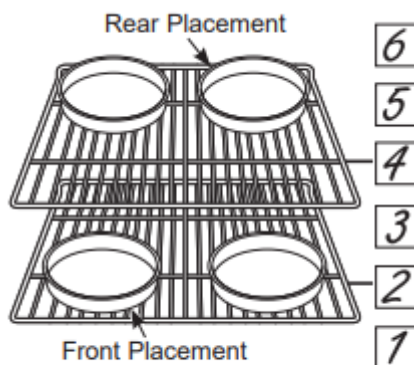

**Rack positions**



# CARE AND CLEANING

## Range – Exterior

Be sure all controls are off and all surfaces are cool before cleaning any part of the range.

**WARNING** If your range is removed for cleaning, servicing or any reason, be sure the anti-tip device is reengaged properly when the range is replaced. Failure to take this precaution could result in tipping of the range and can result in death or serious burns to children or adults.

### Control Lockout

If desired, the touch pads may be deactivated before cleaning.

See Lock Controls in the Oven Controls section in this manual.

Clean up splatters with a damp cloth.

You may also use a glass cleaner.

Remove heavier soil with warm, soapy water. Do not use abrasives of any kind.

Reactivate the touch pads after cleaning.

### Control Panel

It's a good idea to wipe the control panel after each use. Clean with mild soap and water or vinegar and water, rinse with clean water and polish dry with a soft cloth.

Do not use abrasive cleansers, strong liquid cleansers, plastic scouring pads or oven cleaners on the control panel—they will damage the finish, including Black Stainless Steel.

### Oven Exterior

Do not use oven cleaners, abrasive cleansers, strong liquid cleansers, steel wool, plastic scouring pads, or cleaning powders on the interior or exterior of the oven.

Clean with a mild soap and water or vinegar and water solution. Rinse with clean water and dry with a soft cloth. When cleaning surfaces, make sure that they are at room temperature and not in direct sunlight.

If stain on the door vent trim is persistent, use a mild abrasive cleaner and a sponge-scrubber for best results.

Spillage of marinades, fruit juices, tomato sauces and basting liquids containing acids may cause discoloration and should be wiped up immediately. Let hot surfaces cool, then clean and rinse.

### Painted Surfaces

Painted surfaces include the sides of the range and the door, top of control panel and the drawer front. Clean these with soap and water or a vinegar and water solution.

Do not use commercial oven cleaners, cleaning powders, steel wool or harsh abrasives on any painted surface, including Black Stainless Steel.

### Stainless Steel excluding Black Stainless Steel (on some models)

Do not use a steel wool pad; it will scratch the surface.

Cleaners with oxalic acid such as Bar Keepers Friend Soft Cleanser™ will remove surface rust,

tarnish and small blemishes. Use only a liquid cleanser free of grit and rub in the direction of the brush lines with a damp, soft sponge.

To clean the stainless steel surface, use warm sudsy water or a stainless steel cleaner or polish. Always wipe the surface in the direction of the grain. Follow the cleaner instructions for cleaning the stainless steel surface.

To inquire about purchasing cleaning products including stainless steel appliance cleaner or polish, see the Accessories and Consumer Support sections at the end of this manual.

## **Range – Interior**

The interior of your new oven can be cleaned manually or by using Self Clean mode.

Spillage of marinades, fruit juices, tomato sauces and basting liquids containing acids may cause discoloration and should be wiped up immediately. Let hot surfaces cool, then clean and rinse.

### **Manual Cleaning**

Do not use oven cleaners, strong liquid cleansers, steel wool, or scouring pads on the interior of the oven. For soils on the oven bottom and other enameled surfaces, use a gentle abrasive containing oxalic acid, such as Bar Keepers Friend®, with a non-scratch sponge. Take care not to apply any abrasive cleaners or sponges to the door glass, as it will scratch the reflective coating. The oven interior and door glass may be cleaned using a soft cloth with a mild soap and water, or vinegar and water solution. After cleaning, rinse with clean water and dry with a soft cloth.

### **Steam Clean Mode**

The Steam Clean feature is for cleaning light soil from your oven at a lower temperature than Self Clean.

To use the Steam Clean feature:

1. Start with the oven at room temperature
2. Wipe excess grease and soils from the oven
3. Pour one cup of water onto the bottom of the oven
4. Close the door
5. Press the Clean pad, select Steam Clean and then press Start/Enter.

You cannot open the door during 30 minutes Steam Clean cycle. At the end of the Steam Clean cycle, soak up the remaining water, and wipe the moisture-softened soil from the oven walls and door.

### **Self Clean Mode**

Read Self-Cleaning Oven Safety Instructions at the beginning of this manual before using the Self Clean Mode. Self Clean uses very high temperatures to clean the oven interior. For a moderately soiled oven, run a 3 hour self-clean cycle. For a heavily soiled oven, run a 5 hour self-clean cycle. Only self-clean (black) racks and grates may remain in the oven during the self-clean cycle. All other items, including nickel plated (silver) racks, should be removed. If nickel plated (silver) racks

are left in the oven during a self-clean cycle, the racks will tarnish. If either type of rack is left in the oven during a self-clean cycle, the rack may become difficult to slide. See the Oven Racks section for instructions on how to improve.

**IMPORTANT:** The health of some birds is extremely sensitive to the fumes given off during the self-cleaning cycle of any range. Move birds to another well ventilated room.

To use the Self Clean feature:

1. Start with the oven at room temperature.
2. Wipe excess grease and soils from the oven and interior door.
3. Remove all items other than self-clean (black) racks and grates, if desired. See Cleaning the Cooktop to determine if your grates may be self cleaned and for important details regarding grate placement.
4. Close the door.
5. Press the Clean pad, select Self Clean and then press Start/Enter

You cannot open the door during the self-clean cycle. The door will remain locked after the self-clean cycle until the oven cools below the unlocking temperature. At the end of the self-clean cycle, allow the oven to cool and wipe any ash out of the oven.

### **To Stop a Self-Clean Cycle**

Press Cancel/Off and wait for self clean light to go off. Wait until the oven has cooled below the locking temperature to unlatch the door. You will not be able to open the door right away unless the oven has cooled below the locking temperature.

### **On Some Models:**

The surface units are automatically disabled during the self-clean cycle. Make sure that all surface unit controls are turned off at all times during the self-clean cycle. Wait until the self-clean cycle is finished to set and use the sursurface units.

## **Racks**

All racks can be washed with warm, soapy water.

Racks may be more difficult to slide, especially after a self-clean. Put some vegetable oil on a soft cloth or paper towel and rub onto the left and right edges.

## **Oven Heating Elements**

Do not clean the bake element or the broil element. Any soil will burn off when the elements are heated. The bake element is not exposed and is under the oven floor. Clean the oven floor with warm, soapy water



Wipe up heavy soil on the oven bottom.

## Glass Cooktop

### Normal Daily Use Cleaning

ONLY use CERAMA BRYTE® Ceramic Cooktop Cleaner on the glass cooktop. Other creams may not be as effective.

To maintain and protect the surface of your glass cooktop, follow these steps:

1. Before using the cooktop for the first time, clean it with CERAMA BRYTE® Ceramic Cooktop Cleaner. This helps protect the top and makes cleanup easier.
2. Dally use of CERAMA BRYTE® Ceramic Cooktop Cleaner will help keep the cooktop looking new.
3. Shake the cleaning cream well. Apply a few drops of CERAMA BRYTE® Ceramic Cooktop Cleaner directly to the cooktop.
4. Use a paper towel or CERAMA BRYTE® Cleaning Pad for Ceramic Cooktops to clean the entire cooktop surface.
5. Use a dry cloth or paper towel to remove all cleaning residue. No need to rinse.



Clean your cooktop after each spill. Use CERAMA BRYTE® Ceramic Cooktop Cleaner.

NOTE: It is very important that you DO NOT heat the cooktop until it has been cleaned thoroughly.

### Burned-On Residue

NOTE: DAMAGE to your glass surface may occur if you use scrub pads other than those recommended.

1. Allow the cooktop to cool.

2. Spread a few drops of CERAMA BRYTE Ceramic Cooktop Cleaner on the entire burned residue area.
3. Using the included CERAMA BRYTE® Cleaning Pad for Ceramic Cooktops, rub the residue area, applying pressure as needed.
4. If any residue remains, repeat the steps listed above as needed.
5. For additional protection, after all residue has been removed, polish the entire surface with CERAMA BRYTE® Ceramic Cooktop Cleaner and a paper towel.



Use a CERAMA BRYTE® Cleaning Pad for Ceramic Cooktops.

### Heavy, Burned-On Residue

1. Allow the cooktop to cool.
2. Use a single-edge razor blade scraper at approximately a 45° angle against the glass surface and scrape the soil. It will be necessary to apply pressure to the razor scraper in order to remove the residue.
3. After scraping with the razor scraper, spread a few drops of CERAMA BRYTE® Ceramic Cooktop Cleaner on the entire burned residue area. Use a CERAMA BRYTE® Cleaning Pad to remove any remaining residue.
4. For additional protection, after all residue has been removed, polish the entire surface with CERAMA BRYTE® Ceramic Cooktop Cleaner and a paper towel.



The CERAMA BRYTE® Ceramic Cooktop Scraper and all recommended supplies are available through our Parts Center. See the Accessories and Consumer Support sections at the end of this manual.

**NOTE:** Do not use a dull or nicked blade.

### Metal Marks and Scratches

1 Be careful not to slide pots and pans across your cooktop. It will leave metal markings on the cooktop surface. These marks are removable using the CERAMA BRYTE® Ceramic Cooktop Cleaner with the CERAMA BRYTE® Cleaning Pad for Ceramic Cooktops.

2 If pots with a thin overlay of aluminum or copper are allowed to boil dry, the overlay may leave black discoloration on the cooktop. This should be removed immediately before heating again or the discoloration may be permanent.

### **Damage from Sugary Spills and Melted Plastic**

Special care should be taken when removing hot substances to avoid permanent damage of the glass surface. Sugary spillovers (such as jellies, fudge, candy, syrups) or melted plastics can cause pitting of the surface of your cooktop (not covered by the warranty) unless the spill is removed while still hot. Special care should be taken when removing hot substances.

Be sure to use a new, sharp razor scraper.

Do not use a dull or nicked blade.

1. Turn off all surface units. Remove hot pans.
2. Wearing an oven mitt:
  - a. Use a single-edge razor blade scraper to move the spill to a cool area on the cooktop.
  - b. Remove the spill with paper towels.
3. Any remaining spillover should be left until the surface of the cooktop has cooled.
4. Don't use the surface units again until all of the residue has been completely removed.

NOTE: If pitting or indentation in the glass surface has already occurred, the cooktop glass will have to be replaced. In this case, service will be necessary

### **Oven Probe**

The temperature probe may be cleaned with soap and water or a soap-filled scouring pad. Cool the temperature probe before cleaning. Scour stubborn spots with a soap filled scouring pad, rinse and dry.

To order additional temperature probes, see the

Accessories and Consumer Support sections at the end of this manual.

- Do not immerse the temperature probe in water.
- Do not store the temperature probe in the oven.
- Do not leave the temperature probe inside the oven during a self of steam clean cycle.

### **Drawer**

#### **Removable Warming Drawer**

However, the drawer may be removed if further cleaning is needed. Use soap and warm water to thoroughly clean.

To remove the drawer:

1. Pull drawer straight out until it stops.
2. Press the left rail release up and press the right rail release down, while pulling the drawer forward and free.

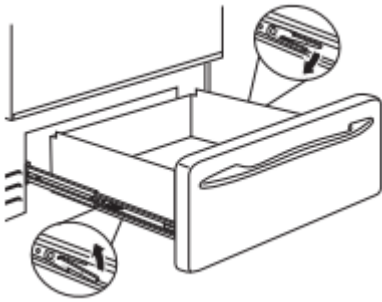

To replace the drawer:

1. Place the left drawer rail around the inner left rail guide and slide it in slightly to hook it.
2. Place the right drawer rail around the inner right rail guide and slide it in slightly to hook it.
3. Slide the drawer all the way in.

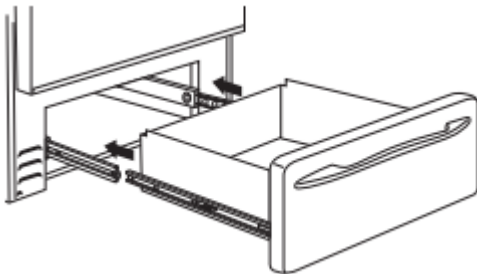

## Oven Light

**NOTE:** The glass cover should be removed only when cold. Wearing latex gloves may offer a better grip. Before replacing the bulb, disconnect electrical power to the oven at the main fuse or circuit breaker panel. Let the bulb cool completely before removing it. For your safety do not touch a hot bulb with a damp cloth. If you do the bulb may break.

**To remove:** Turn the glass cover counterclockwise  $\frac{1}{4}$  turn until the tabs of the glass cover clear the grooves of the socket and pull the cover off. Remove the bulb.

**To replace:** Put in a new 40-watt appliance bulb. Place the tabs of the glass cover into the grooves of the socket. Turn the glass cover clockwise  $\frac{1}{4}$  turn

NOTE:

- A 40-watt appliance bulb is smaller than a standard 40-watt household bulb.
- Reconnect electrical power to the oven once the new bulb is installed.
- For improved lighting inside the oven, clean the glass cover frequently using a wet cloth. This should be done when the oven is completely cool.

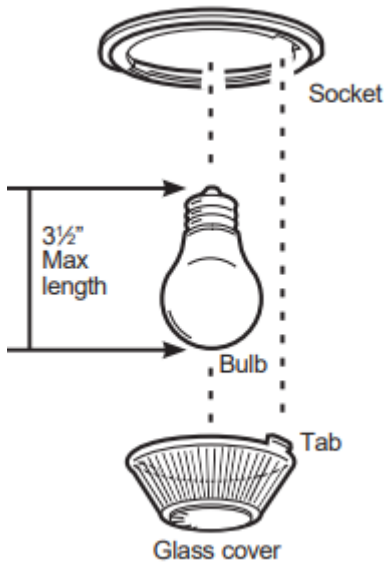

## Oven Door

### To Remove the door:

1. Fully open the door
2. Pull the hinge locks up and away from the range frame to the unlocked position.
3. Firmly grasp both sides of the door near the top.
4. Close door until the top of the door is approximately 6" from the range frame.
5. Lift door up and away from the range until both hinge arms are clear of the slots in the range frame.

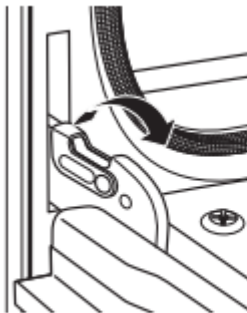

Pull hinge locks up to unlock



Removal position

## To Replace the Door:

1. Firmly grasp both sides of the door near the top
2. With the door at the same angle as the removal position, rest the notch on the underside of the left hinge arm on the bottom edge of the left hinge slot. The notch in the hinge arm must be fully seated into the bottom of the slot. Repeat for the right side.
3. Fully open the door. If the door will not fully open, the notches in the bottoms of the hinge arms have not seated correctly in the bottom edge of the slot. Lift the door off the range and repeat previous step.
4. Push the hinge locks toward the range cavity and down to the locked position.
5. Close the oven door.

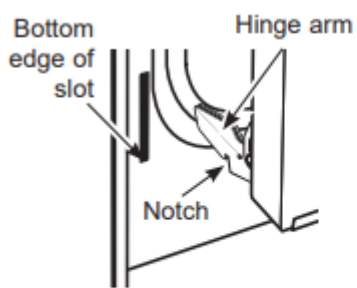

Rest notch on bottom edge of hinge slot

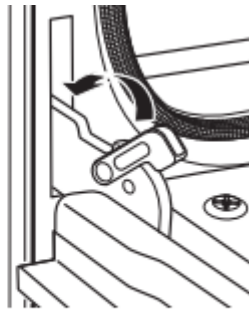

Push hinge locks down to lock

## TROUBLESHOOTING

Troubleshooting Tips ... Before you call for service

Save time and money! Review the charts on the following pages first and you may not need to call for service.

| Problem   | Possible Cause  | What To Do   |
|---|---|--|
| <p><b>Surface units do not work properly or flashing power setting.</b></p> | Improper cookware being used.   | Wrong pan type. Use a magnet to check that cookware is induction-compatible. Use a flat induction-compatible pan that meets the minimum size for the element being used. See the Pan size and shape section. |
|   | Pan is too small.   | Pan size is below the minimum size for the element being used. See the Pan size and shape section. Use smaller cookware.   |
|   | Pan not positioned correctly.   | Center the pan in the cooking zone.  |
|   | Pan is not in full contact with glass surface.  | Pan must be flat.  |
|   | In some areas, the power (voltage) may be low.  | Cover pan with a lid until desired heat is obtained.   |
|   | A fuse in your home may be blown or the circuit breaker tripped.  | Replace the fuse or reset the circuit breaker.   |
|   | Cooktop controls improperly set.  | Check to see that the control is set properly. Press the +/- button then + or -  |
| <p><b>Surface unit setting changed or turned off unexpectedly.</b></p>      | High cooktop temperature.   | Allow the internal fan to cool the cooktop. Check for liquid that has boiled dry.  |
| <p><b>Scratches (may appear as cracks) on cooktop glass surface.</b></p>    | Incorrect cleaning methods being used.  | Scratches are not removable. Tiny scratches will become less visible in time as a result of cleaning.  |
|   | Cookware with rough bottoms being used or coarse particles (salt or sand) were between the cookware and the surface of the cooktop. | To avoid scratches, use the recommended cleaning procedures. Make sure bottoms of cookware are clean and dry before use, and use cookware with smooth bottoms.   |



|  |  |   |
|--|--|---|
|  | cooktop. Cookware has been slid across the cooktop surface.  |   |
| <b>Areas of discoloration on the cooktop.</b>  | Food spillovers not cleaned before next use.   | See the Cleaning the glass cooktop section.   |
|  | Hot surface on a model with a light-colored cooktop.   | This is normal. The surface may appear discolored when it is hot. This is temporary and will disappear as it cools.   |
| <b>Plastic melted to the surface.</b>  | Hot cooktop came into contact with plastic placed on the hot cooktop.  | See the Glass surface—potential for permanent damage section in the Cleaning the glass cooktop section.   |
| <b>Pitting (or indentation) of the cooktop.</b>  | Hot sugar mixture spilled on the cooktop.  | Call a qualified technician for replacement.  |
| <b>My new oven doesn't cook like my old one. Is something wrong with the temperature settings?</b> | Your new oven has a different cooking system from your old oven and therefore may cook differently than your old oven. | For the first few uses, follow your recipe times and temperatures carefully. If you still think your new oven is too hot or too cold, you can adjust the temperature yourself to meet your specific cooking preferences. This adjustment affects Bake, and Convection Bake temperatures; it will not affect Broil or Clean. |
| <b>Food does not bake properly.</b>  | Oven controls improperly set.  | See the Cooking Modes section.  |
|  | Rack position is incorrect or rack is not level.   | See the Cooking Modes section and Cooking Modes section.  |
|  | Incorrect cookware or cookware of improper size being used.  | See the Cookware section.   |
|  | Oven temperature needs adjustment.   | See the Special Features section.   |



|  |   |  |
|--|---|--|
|  | Ingredient substitution.  | Substituting ingredients can change the recipe.  |
| <b>Food does not broil properly.</b>         | Oven controls improperly set.   | Make sure you select the appropriate broil mode. |
|  | Improper rack position being used.  | See Cooking Guide for rack location suggestions. |
|  | Food being cooked in a hot pan.   | Make sure cookware is cool.                      |
|  | Cookware not suited for broiling.   | Use a pan specifically designed for broiling.    |
|  | The probe is plugged into the outlet in the oven.   | Unplug and remove the probe from the oven.       |
|  | Aluminum foil used on the broiling pan and grid has not been fitted properly and slit as recommended. | If using aluminum foil conform to pan slits.     |
|  | In some areas the power (voltage) may be low.   | Preheat the broil element for 10 minutes.        |
| <b>Oven temperature too hot or too cold.</b> | Oven temperature needs adjustment.  | See the Special Features section.                |



|  |   |  |
|--|---|--|
| <b>Oven does not work or appears not to work.</b>                    | Plug on range is not completely inserted in the electrical outlet.                                    | Make sure electrical plug is plugged into properly grounded outlet.  |
|  | A fuse in your home may be blown or the circuit breaker tripped.                                      | Replace the fuse or reset the circuit breaker.   |
|  | Oven controls improperly set.   | See the Using the Oven section.  |
|  | Oven is in Sabbath Mode.  | Verify, that the oven is not in Sabbath Mode. See the Special Features section.  |
| <b>“Crackling” or “popping” sound.</b>                               | This is the sound of the metal heating and cooling during both the cooking and cleaning functions.    | This is normal.  |
| <b>Why is my range making a "clicking" noise when using my oven?</b> | Your range cycles the heating elements by turning relays on and off to maintain the oven temperature. | This is normal.  |
| <b>Clock and timer do not work.</b>                                  | A fuse in your home may be blown or the circuit breaker tripped.                                      | Replace the fuse or reset the circuit breaker.   |
|  | Plug on range is not completely inserted in the electrical outlet.                                    | Make sure electrical plug is plugged into properly grounded outlet.  |
|  | Oven controls improperly set.   | See the Using the kitchen timer section.   |
| <b>Oven door is crooked.</b>   | The door is out of position.  | Because the oven door is removable, it gets out of position during installation. To straighten the door, re-install the door. See the "Lift-Off Oven Door" instructions in the "Cleaning" section. |
| <b>Oven light does not work.</b>                                     | Light bulb is loose or defective.   | Tighten or replace bulb.   |



|   |   |   |
|---|---|---|
|   | Pad operating light is broken.                            | Call for service.   |
| <b>Oven will not self-clean.</b>                    | The temperature is too high to set a selfclean operation. | Allow the oven to cool and reset the controls.  |
|   | Oven controls improperly set.                             | See the Cleaning the Oven section.  |
|   | The probe is plugged into the outlet in the oven.         | Remove the probe from the oven.   |
| <b>Oven will not steam clean.</b>                   | Display flashes HOT.                                      | Allow the oven to cool to room temperature and reset the controls.  |
|   | Oven controls improperly set.                             | See the Using Steam Clean section.  |
|   | Oven door is not closed.                                  | Make sure you close the door to start steam clean cycle.  |
| <b>Excessive smoking during clean cycle.</b>        | Excessive soil or grease.                                 | Press the <b>Cancel/Off</b> pad. Open the window to rid the room of smoke. Wait until the <b>LO</b> light goes off. Wipe up the excess soil and grease at the end of the clean cycle. |
| <b>Excessive smoking during broiling.</b>           | Food too close to burner element.                         | Lower the rack position of the food.  |
| <b>Oven door will not open after a clean cycle.</b> | Oven too hot.   | Allow the oven to cool below locking temperature.   |
| <b>Oven not clean after a clean cycle.</b>          | Oven controls improperly set.                             | See the Cleaning the Oven section.  |
|   | Oven was heavily soiled.                                  | Clean up heavy spillovers before starting clean cycle. Heavily soiled ovens may need to be cleaned again or for a longer period of time.  |



|   |   |   |
|---|---|---|
| <p><b>"LOCK DOOR" flashes in the display.</b></p>               | <p>The self-clean cycle has been selected but the door is not closed.</p>   | <p>Close the oven door.</p>   |
| <p><b>DOOR LOCK light is on when you want to cook.</b></p>      | <p>The oven door is locked because the temperature inside the oven has not dropped below the locking temperature.</p> | <p>Press the <b>Cancel/Off</b> pad. Allow the oven to cool.</p>   |
| <p><b>"F— and a number or letter" flash in the display.</b></p> | <p>You have a function error code.</p>  | <p>Press the <b>Cancel/Off</b> pad. Allow the oven to cool for one hour. Put the oven back into operation.</p>  |
|   | <p>If the function code repeats.</p>  | <p>Disconnect all power to the oven for at least 30 seconds and then reconnect power. If the error code repeats, visit <b>cafeappliance.com</b> for <b>service</b>.</p> |



|  |   |   |
|--|---|---|
| <b>Display goes blank.</b>   | A fuse in your home may be blown or the circuit breaker tripped.  | Replace the fuse or reset the circuit breaker.  |
|  | The clock is turned off.  | See the Special features section.   |
| <b>Oven or cooktop will not stay set.</b>  | Function error.   | Disconnect all power for at least 30 seconds, then reconnect power. If repeating, visit <a href="http://cafeappliances.com/service">cafeappliances.com/ service</a> .   |
| <b>Power outage, clock flashes.</b>  | Power outage or surge.  | Reset the clock. If the oven was in use, reset it by pressing the <b>Cancel/Off</b> pad, the clock and resetting any cooking functions.   |
| <b>"Burning" or "oily" odor emitting from the vent.</b>  | This is normal in a new oven and will disappear in time.  | To speed the process, set a self-clean cycle for a minimum of 3 hours. See the Cleaning section.  |
| <b>Strong odor.</b>  | An odor from the insulation around the inside of the oven is normal for the first few times the oven is used.   | This is temporary and will go away after a few uses or a selfclean cycle.   |
| <b>Fan noise.</b>  | A convection fan may automatically turn on and off.   | This is normal. The fan is designed to operate intermittently to maximize cooking evenness. The convection fan will operate during preheat and bake cycle. The fan will turn off after the oven is cooled to the set temperature. This is normal. |
|  | A cooling fan may automatically turn on and off.  | This is normal. The cooling fan will turn on to cool internal parts. It may run after the oven is turned off.   |
| <b>My oven door glass appears to be "tinted" or have a "rainbow" color. Is this defective?</b> | No. The inner oven glass is coated with a heat barrier to reflect the heat back into the oven to prevent heat loss and keep the outer door cool while baking. | This is normal. Under certain light or angles, you may see this tint or rainbow color.  |



|  |   |   |
|--|---|---|
| <b>Sometimes the oven takes longer to preheat to the same temperature.</b> | Cookware or food in oven.   | The cookware or food in the oven will cause the oven to take longer to preheat. Remove the cookware or food to reduce preheat time.                       |
|  | Number of racks in oven.  | Adding more racks to the oven will cause the oven to take longer to preheat. Remove the extra racks.  |
|  | Different cooking modes.  | The different cooking modes use different methods to heat the oven for the specified mode. Some modes will take longer to preheat (i.e. convection bake). |
| <b>Display flashes.</b>  | Power failure.  | Reset the clock.  |
| <b>Control signals after entering cooking time or start time.</b>          | You forgot to enter a bake temperature or cleaning time.  | Touch the <b>Bake</b> pad and desired temperature or the <b>Self Clean</b> pad and desired clean time.  |
| <b>Oven racks are difficult to slide.</b>                                  | The shiny, silver-colored racks were cleaned in a self-clean cycle.   | Apply a small amount of vegetable oil to a paper towel and wipe the edges of the oven racks. Do not spray with Paraflex or other lubricant sprays.        |
| <b>Steam from the vent.</b>  | When using the ovens, it is normal to see steam coming out of the oven vents. As the number of racks or amount of food being cooked increases, the amount of visible steam will increase. | This is normal.   |
| <b>Warming drawer will not work.</b>                                       | A fuse in your home may be blown or the circuit breaker tripped.  | Replace the fuse or reset the circuit breaker.  |
|  | Controls improperly set.  | See the Using the warming drawer section.   |
| <b>Excessive condensation in the drawer.</b>                               | Liquid in drawer.   | Remove liquid.  |

|   |                               |   |
|---|-------------------------------|---|
|   | Uncovered foods.              | Cover food with lid or aluminum foil.         |
|   | Temperature setting too high. | Reduce temperature setting.                   |
| <b>Food dries out in the warming drawer.</b>                  | Moisture escaping.            | Cover food with lid or aluminum foil.         |
|   | Drawer not fully closed.      | Push drawer in until latch engages.           |
| <b>Water remaining on oven floor after Steam Clean cycle.</b> | This is normal.               | Remove any remaining water with a dry sponge. |



|   |  |  |
|---|--|--|
| <b>“Probe” appears in the display.</b>  | This is reminding you to enter a probe temperature after plugging in the probe.                        | Enter a probe temperature.   |
| <b>Probe actual temperature is not stable while charger is inserted</b>                                   | Electrical noise is impacting the signal.  | Probe should be charged before cooking. Leave probe plugged in while cooking.  |
| <b>My precision probe JXSOUV1 won't pair</b>  | Existing precision probes are not compatible with new features.  | Connect a model compatible precision probe.  |
| <b>My precision probe is not accurately maintaining low temperatures</b>                                  | The pot size, pot set-up, and/or burner size you are using may be unsuitable to hold low temperatures. | Remove the lid, use a larger diameter burner, or a smaller burner. Please keep your unit on a flat surface and install upcoming updates to improve performance.                                      |
| <b>Pan won't pair or activate when tapping handle</b>   | Tapping force is too light.  | Double tap the pan with firm taps (or knock the black plastic endcap).   |
|   | Battery in pan is low or dead.   | Replace AAA battery, installing with positive end of handle.   |
|   | Using different pan hardware.  | Check that your pan has a black endcap with two screws from the end of the handle. Remove the screws and install an oval module reading "Hestan Cue" which is required to work with Cafe appliances. |
| <b>Experiencing performance or minor technical issues including seeing 20F or 100F as set temperature</b> | Old unit or pan software.  | Connect your unit to the Cafe app and update the software. Connect your unit and pan to the Hestan Smart Cooking app and update the software.  |
| <b>The unit cancelled my precision cooking mode</b>   | Battery in device is low or dead.  | Replace AAA battery in pan, or charge the unit.  |
|   | Old unit or pan software.  | Connect your unit to the Cafe app and update the software. Connect your unit and pan to the Hestan Smart Cooking app and update the software.  |



|  |   |  |
|--|---|--|
|  |   | Hestan Smart Cooking app and update software.  |
|  | Your precision cooking device has gone out of range.  | This could indicate a problem with the the problem persists, please contact the manufacturer.                                    |
|  | Your precision cooking device had a computation malfunction.  |  |
|  | The unit lost communication with your precision cooking device.   | This could indicate a problem with the the unit. If the problem persists, please the device or unit manufacturer.                |
|  | Some cooking techniques and set temperatures in combination may trigger a fault in the temperature sensing algorithm. | Re-start the precision cooking mode a problem persists under the same cond not consistent in other use cases, cont manufacturer. |

**Warning**

This content is compiled from multiple sources and is provided for reference purposes only. It may not be complete or fully applicable to all situations. If you are unable to resolve your issue, please contact the product manufacturer or an authorized service provider for official support.

