

Instructions for use OVEN

YOUR OVEN

Control panel

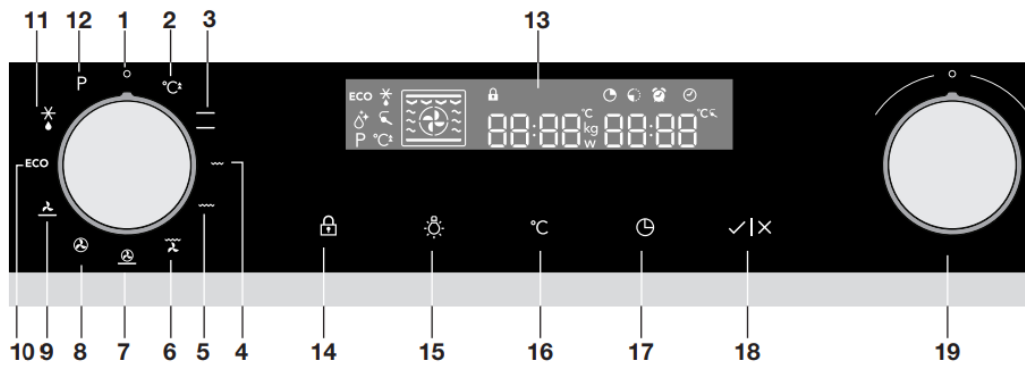

1. Off
2. Quick preheat
3. Top heat + bottom heat
4. Small grill
5. Large grill
6. Grill with fan
7. Hot air + bottom heat
8. Hot air
9. Bottom heat with fan
10. ECO cooking
11. Defrosting
12. Pyrolysis
13. Display (cooking information and timer)
14. Child lock
15. Oven lamp
16. Temperature
17. Timer
18. Start/Stop
19. Selection dial

Note:

For the best touch response, touch the buttons with the main part of your fingertip. Every time you press a button during use, a short signal will sound.

Description

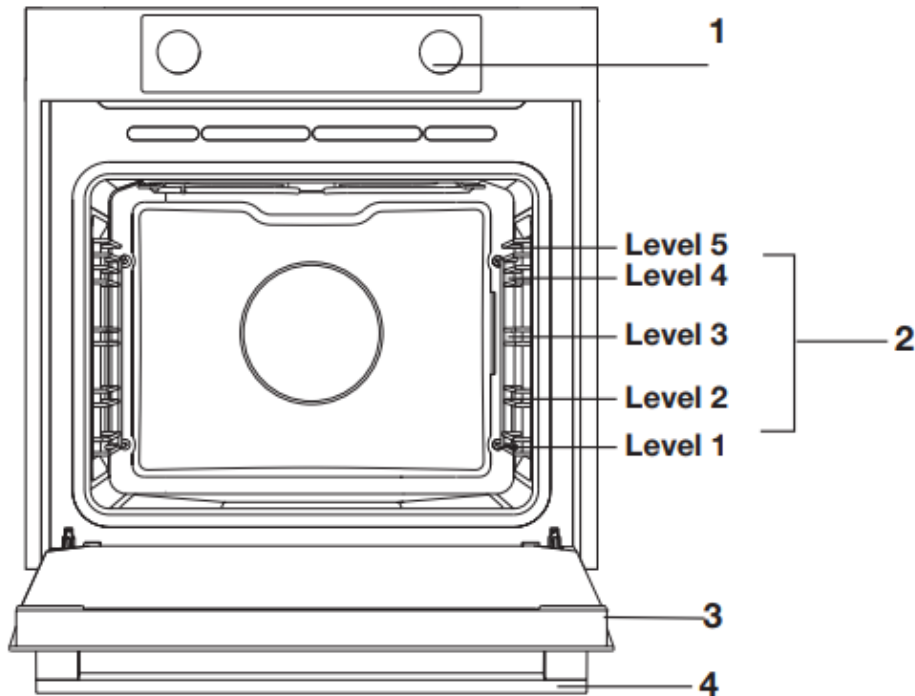

- 1. Control panel
- 2. Rack levels
- 3. Oven door
- 4. Handle

Guide rails/Telescopic guide rails

- The oven has four or five guide rails (Level 1 to 4/5), depending on the model. Level 1 is mainly used in combination with bottom heat. The two upper levels are mainly used for the grill function.
- Place the oven rack, baking tray or steam dish in the gap between the guide rail sliders.
- A number of shelf levels can have fully-retractable telescopic guide rails, depending on the model.
 - Pull the telescopic guide rails out of the oven cavity completely and place the oven rack / baking tray / steam dish on them. Then slide the oven rack / baking tray / steam dish on the telescopic guide rails, back into the oven cavity.





- Only close the oven door when the telescopic guide rails have been returned completely back into the oven cavity.



Note: remove the guide rails / telescopic guide rails out of the oven if you are going to use the Pyrolysis function!

Accessories

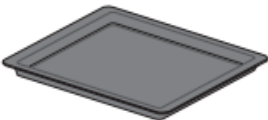
Your appliance is accompanied by a range of accessories, depending on the model. Only use original accessories; they are specially suited to your appliance. Be sure that all the accessories that are being used are able to withstand the temperature settings of the chosen oven function.

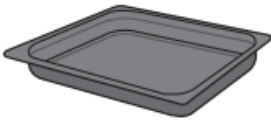
Note: not all accessories are suitable/available for every appliance (it may also differ by country). When purchasing, always provide the exact identification number of your appliance. Please see the sales brochures or check online for more details about optional accessories.

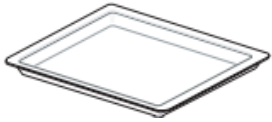
Accessories that can be supplied with your appliance (depending on the model)	
	<p>Enamelled baking tray; to be used for pastries and cakes.</p> <ul style="list-style-type: none"> • Do not use the enamelled baking tray for microwave functions! • Suitable for pyrolysis cleaning.
	<p>Oven rack; mainly used for grilling. A steam dish or pan with food can also be placed on the oven rack.</p> <ul style="list-style-type: none"> • The oven rack is equipped with a safety peg. Lift the rack slightly at the front to slide it out of the oven. • Do not use the oven rack for microwave functions!
	<p>Deep enamelled baking tray; to be used for roasting meat and baking moist pastry. It can also be used as a drip tray. Place the deep baking tray into the first level for use as a drip tray during grilling.</p> <ul style="list-style-type: none"> • Do not use the deep enamelled baking tray for microwave functions!

	<ul style="list-style-type: none"> • Suitable for pyrolysis cleaning.
	<p>Glass baking tray; for microwave and oven use.</p> <ul style="list-style-type: none"> • NOT suitable for pyrolysis cleaning.
	<p>Culisensor; can be used to measure the core temperature of the dish. When the desired temperature is reached, the cooking process will be stopped automatically.</p>
	<p>Pyrolysis guide rails; only use these guide rails to clean an enamelled baking tray during pyrolysis (replace the guide rails / telescopic guide rails with these special pyrolysis guide rails). Please note: the high temperature during pyrolysis may cause the pyrolysis guide rails to discolour.</p>

Door

- The door switches interrupt the operation of the oven when the door is opened during use. The oven continues operating when the door is closed.
- This oven has a 'Soft close door system'. When closing the oven door, this system dampens the movement, from a certain angle, and silently closes the oven door.

Cooling fan

- The appliance is equipped with a cooling fan that cools the casing and control panel.

USE

Initial use

Set the current time

When you connect the appliance to the mains electricity for the first time, the display lights up. After three seconds the clock symbol and '12:00' will flash on the display.

Set the current time

When you connect the appliance to the mains electricity for the first time, the display lights up. After three seconds the clock symbol and '12:00' will flash on the display.

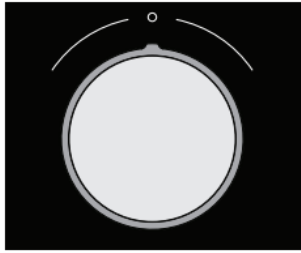

Selection dial



Start/stop button



Timer button

1. Turn the 'selection dial' to set the current time.

You can set the values in the display faster by turning the selection dial further to the left or right.

2. Confirm the settings by pressing 'start/stop'.

If you do not press anything, the settings will be saved automatically after three seconds.

You can always set the current time by pressing the 'timer button' twice. Then turn the 'selection dial' to set the current time. Confirm the settings by pressing 'start/stop'.

If nothing is pressed, the settings are stored automatically after three seconds.

Using your oven

The oven has 10 oven functions and 1 cleaning function. Consult the table to select the correct oven function for the dish.



Oven function dial



Temperature button

1. Place the dish in the oven.

For most dishes you should first preheat the oven.

2. Turn the 'oven function dial' to the desired setting.

The selected pictogram will appear on the display.

3. Press the 'temperature button'.

4. Set the oven to the desired temperature using the 'selection dial' (between 30-275 °C / for ECO between 120-275 °C).

5. If desired, set a cooking time by pressing the 'timer button' and use the 'selection dial' to set the desired time.

6. Press the 'start/stop' button.

The set oven function will be started and the oven will be heated to the selected temperature. The temperature symbol in the display will flash. When the oven has reached the selected temperature, the temperature symbol in the display will stay lit.





Notes

- The temperature can be changed during cooking.
- Cooking times are rough estimates and can vary depending on a number of conditions.
- For certain dishes, the oven should be preheated.
- If you use baking paper, this should be able to withstand high temperatures.
- A lot of steam is released when cooking larger pieces of meat or dishes using dough, such as pies. This can cause condensation on the oven door. This is a normal occurrence and does not influence the functioning of the appliance. When the cooking process has ended, dry the door and the glass.
- Prevent condensation from forming and do not allow hot food to cool in a closed oven.
- Any glass dishes you use must be able to withstand temperatures of 275 °C.





Oven settings

Use the table to select the right oven function. Also consult the cooking instructions on the food packaging.

Function	Description	Recommended temp. °C
	Quick preheat Use this function to heat the oven quickly to the desired temperature. This function is not suitable for cooking food! The preheat process is	160

	complete once the oven has been preheated to the desired temperature.	
	Top heat + bottom heat Heat is generated by the heating elements at the top and bottom of the appliance. This setting is suitable for baking and roasting.	200
	Small grill Food is heated by the top grill heating element.	240
	Large grill Food is heated by the heating element (the grill) at the top of the oven. The top heating element is activated simultaneously to increase the effect of the elements.	240
	Grill + fan The fan distributes the heat generated from the top heating element. You can use this function for grilling meat and fish.	170
	Hot air + bottom heat The combination of hot air and bottom heat provides a crispy and browned result.	200

Each oven function has a number of basic or standard settings that you can adjust.

	<p>Hot air</p> <p>Food is heated by hot air supplied from the back of the oven. This setting uses even heating and is ideal for baking.</p>	<p>180</p>
	<p>Bottom heat + fan</p> <p>The bottom element heats the dish and the heat is distributed by the fan.</p>	<p>180</p>
	<p>ECO cooking</p> <p>In this mode, power consumption during the cooking process is optimized. This mode is used for roasting meat and baking pastry.</p> <p>By making use of the residual heat this setting gives a low energy consumption (energy class in accordance with EN 60350-1). On this setting the oven does not display the actual temperature in the oven.</p>	<p>180</p>
	<p>Defrosting</p> <p>The air circulates with no heaters activated. Only the fan will be activated. This is used to slowly thaw frozen food.</p>	
	<p>Pyrolysis</p> <p>This function allows automatic cleaning of the oven cavity/ interior using high temperature (approx. 460 °C), which incinerates the fat residues</p>	

You adjust the settings by pressing the relevant button (before pressing the 'start/stop' button).

	and other impurities, reducing them to ashes.	
--	---	--

Certain settings are not available for all programmes; if this is the case you will be alerted by a sound signal.

Adjusting the cooking temperature

- Turn the 'oven function dial' to the desired oven function. *The selected pictogram will appear on the display and the prior set temperature will flash.*
- Press the 'temperature button'. Set the oven to the desired temperature using the 'selection dial'.

Oven functions

Quick preheat



Quick preheat

Use this function to heat the oven quickly to the desired temperature. **This function is not suitable for cooking food!**

- Turn the 'oven function dial' to the 'quick preheat' position. *The prior set temperature will be displayed. You can alter this temperature.*

Note:

Preheat will begin after you have started the oven using the 'start/stop' button.

Preheat is complete when the set temperature is reached and a signal sounds.

Top heat + bottom heat



Top and bottom heat

Heat is generated by the heating elements at the top and bottom of the appliance. This setting is suitable for traditional baking and roasting.

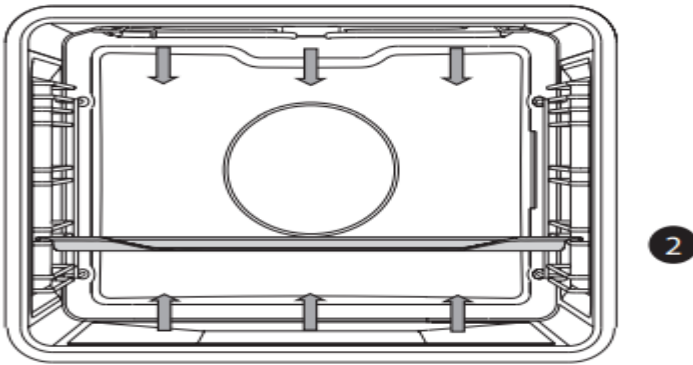

- The baking tray or the grill rack is usually placed at level 2.
- Preheating is recommended.

Small Grill



Small grill

Food is heated by the grill element.

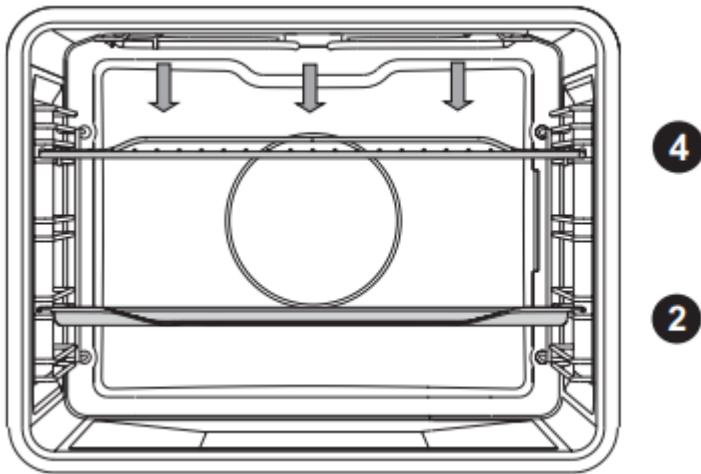

- For grilling, the grill rack is usually placed at level 4 and the baking tray at level 2.
- Keep an eye on the cooking process. At high temperatures, meat can burn quickly.
- Preheat the oven for 5 minutes.

Large grill



Large grill

The heat comes from the top element and the grill element. This setting is particularly useful for dishes and baked food that require a real bottom crust or browning. Use this just before the end of the baking or roasting time.

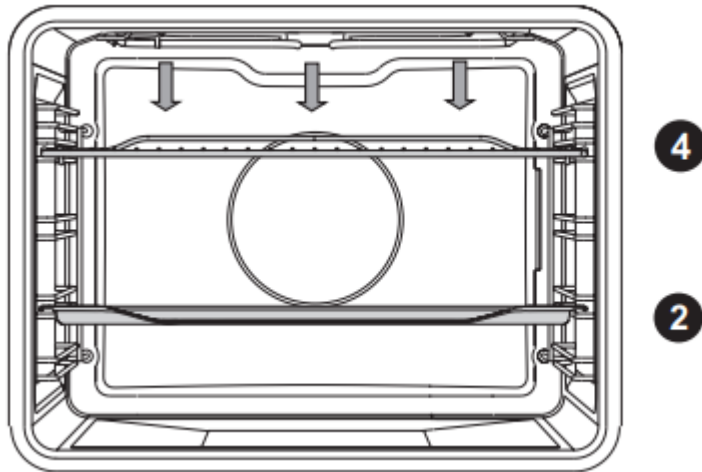

- For grilling place the oven rack on the fourth guide rail level and the baking tray on the second guide rail level.

Grill + fan



Grill and fanr

The fan distributes the heat generated from the top heating element. You can use this function for grilling meat, fish, poultry and vegetables. It gives food a crispy texture without it needing to be turned over.

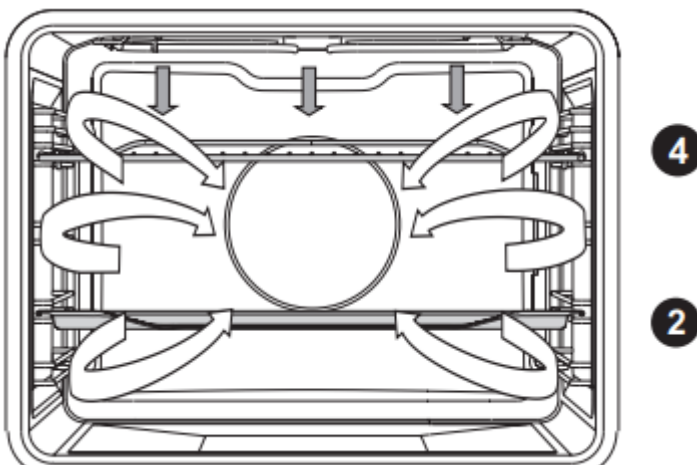

- For grilling, the grill rack is usually placed at level 4 and the baking tray at level 2.
- Keep an eye on the cooking process. At high temperatures, meat can burn quickly.

- Preheat the oven for 5 minutes.

Hot air + bottom heat



*Hot air and bottom
heat*

Food is heated using a combination of hot air and bottom heat.

This setting is used for a crispy and browned result.

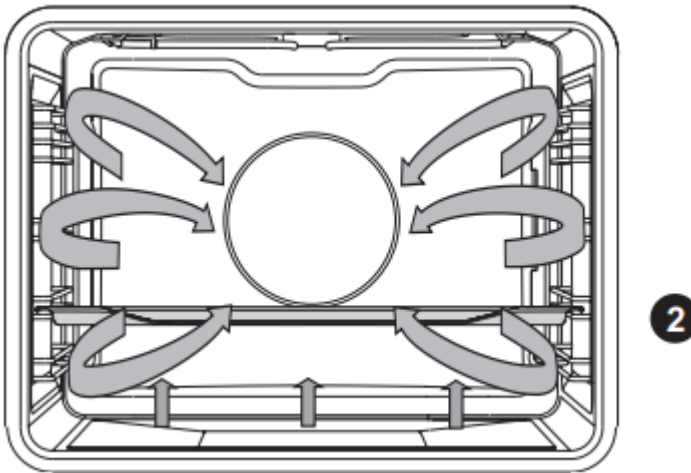

- The baking tray or the grill rack is usually placed at level 2.
- Preheating is recommended.

Hot air



Hot air

Food is heated by hot air from a fan and the heating element at the back of the oven. This setting uses even heating and is ideal for baking.

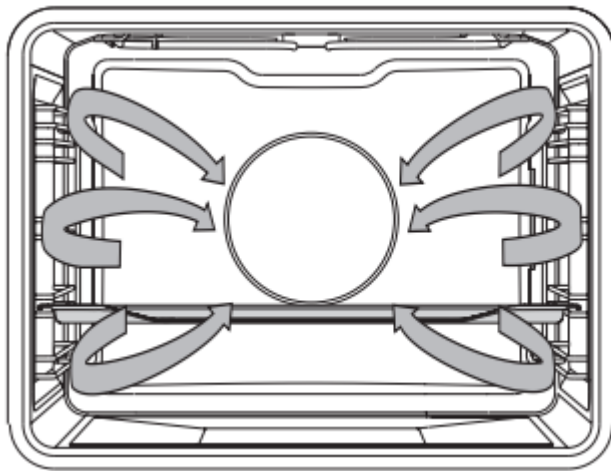

- Place the tray at level 2.
- Preheating is recommended.

Bottom heat + fan



Bottom heat and fan

The bottom element heats the dish and the heat is distributed by the fan. This setting is used for baking yeasted pastry and preserving fruit and vegetables.

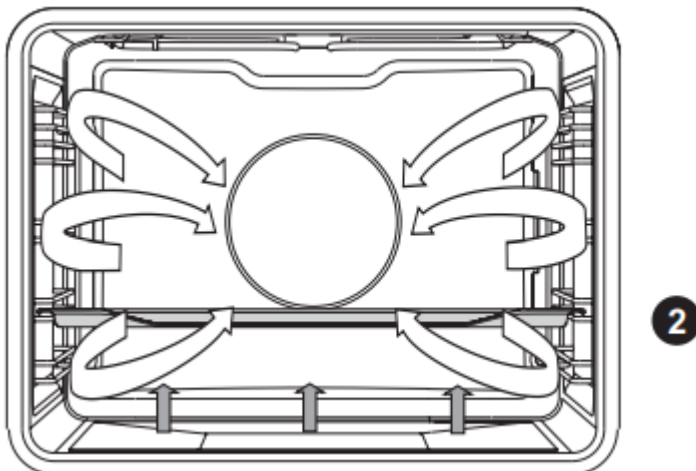

- Place the tray at level 2.
- Preheating is recommended.

ECO cooking



ECO heating

In this mode, power consumption during the cooking process is optimized. This mode is used for roasting meat and baking pastry. By making use of the residual heat this setting gives a low energy consumption (energy class in accordance with EN 60350-1). On this setting the oven does not display the actual temperature in the oven.

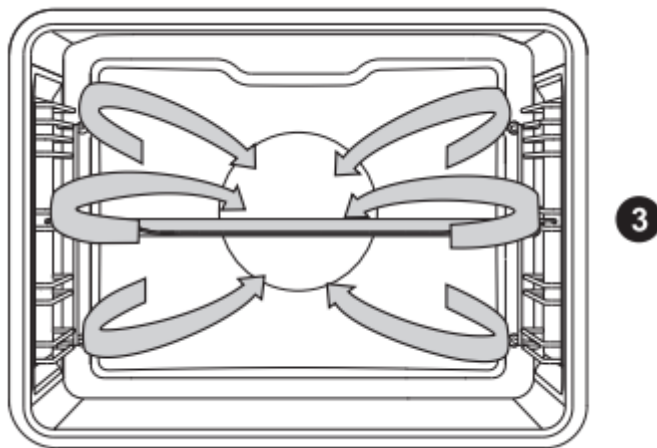

- Place the tray at level 3.

Defrosting



Defrosting

In the defrost function the fan circulates the air. No heat elements are switched on. Use this function for slow defrosting of frozen dishes (cakes, biscuits, cookies, bread, bread rolls and frozen fruit).

- If desired, set a different defrost time by pressing the 'timer button' and setting the time using the 'selection dial'.

- Turn the food over after half the defrosting time has elapsed; stir the food or break up large pieces if these are frozen together.

Timer

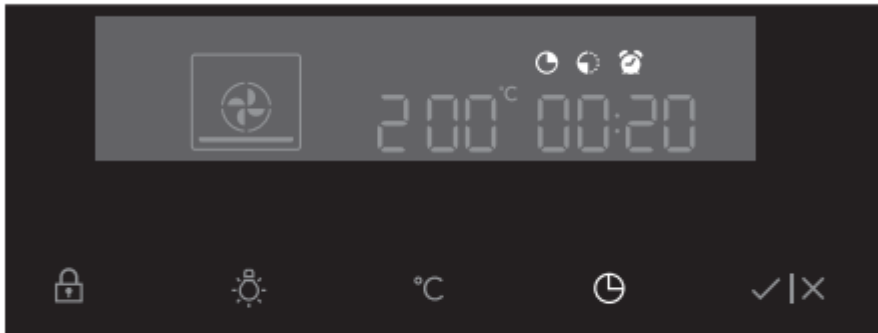

Setting the timer

- Press the 'timer button' twice.
- To set the time, turn the 'selection dial' to the current time.

Timer function

- Select an oven function using the 'oven function dial' and set the temperature.
- Press the 'timer button' several times to select a timer function. *The pictogram for the selected timer function lights up on the display and the adjustable start/end time will flash. The other pictograms are dimmed.*
- Press the 'start/stop button' to start the cooking process. *The elapsed cooking time will be displayed.*

'Setting the 'cooking time'



- In this setting you can set how long the oven needs to operate (cooking time).

'Setting the 'end time'



- In this setting you can set the time the oven should switch off. A cooking time first needs to be set. Ensure that the clock is set precisely to the current time.

Example:



- Current time: 12:00
- Cooking time: 2 hours
- End of cooking: 18:00 hours



First set the cooking time, for example 2 hours. The sum of the current time and the cooking time is displayed automatically (14:00 hours). Press the 'timer button' again to select the 'end time' pictogram and set the time when the cooking should be ended (18:00 hours).

- **Press the 'start/stop button' to start the cooking process.** *The timer will delay the cooking process until the appropriate time. The pictogram will now light up. The oven will switch on automatically (16:00 hours) and switch off at the selected time (18:00 hours).*

'Timer alarm' function \



- The 'timer alarm' function can be used independently of the oven.

The highest possible setting is 10 hours.

The last minute of the run time is displayed in seconds.

The oven will switch off automatically once the set time has elapsed (end of cooking). A signal will sound that you can switch off by pressing the 'start/stop' or 'timer' button. The sound signal will stop automatically after one minute.



You can cancel all timer functions by setting the time to '0'. If the appliance has been inactive for a few minutes, it will switch to standby. The current time appears and the selected timer function will light up.

Selecting additional functions

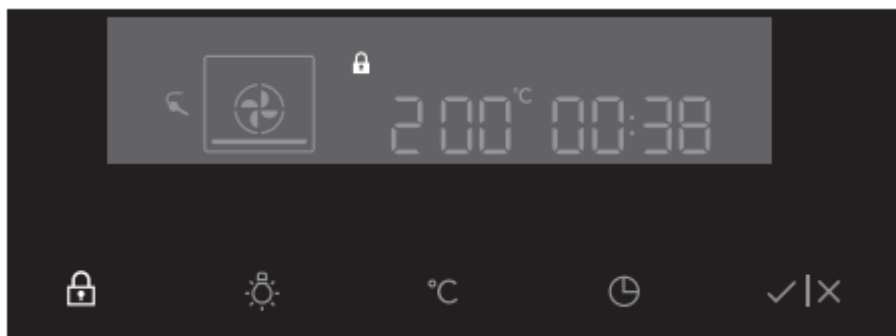

Certain settings are not available for all programmes; if this is the case you will be alerted by a sound signal.

Child lock



Child lock button

With the oven's childproof lock you can lock the control panel to prevent unintended use of the oven.

You can activate the child lock by pressing the 'child lock button' for a few seconds.

A pictogram in the form of a lock appears in the display. This indicates that all functions are locked.

- To deactivate the child lock, press the button again for a few seconds.

The lock pictogram disappears from the display, indicating that all functions are unlocked.

Note:

Once the child lock is activated and no timer function has been set (only the clock is displayed), the oven will not work. If the child lock is activated after a timer function has been set, the oven will work; however, the settings cannot be changed.

When the child lock is activated, oven functions or additional functions cannot be changed. The cooking process can only be ended by turning the 'oven function dial' to '0'.

The child lock remains activated even after the oven has been switched off. The child lock needs to be deactivated before you can select a new programme.

Oven lamp



Lamp button

- The oven lamp will light automatically if the oven door is opened or if the oven is switched on.
- After the end of the cooking process, the lamp stays lit for another minute.
- You can switch off the oven lamp by pressing the 'lamp button'.

Sound signal



Temperature button

The volume of the sound signal can be set if no timer function has been activated (only the time is displayed).

- The 'Oven function dial' must be in the '0' position.
- Press and hold the 'temperature button'.

Bars appear on the display that are (partly) fully lit.

- Turn the 'selection dial' to select one of three volume levels (one, two or three bars lit) or no sound (no bar lit).
- The setting will be saved automatically after 3 seconds and the time will be displayed.

Reduce display contrast



Lamp button

- The 'oven function dial' must be in the '0' position.
- Press and hold the 'lamp button' for 5 seconds.

Bars appear on the display that are (partly) fully lit.

- Turn the 'selection dial' to adjust the dimming level of the display (one, two or three bars).

The setting will be saved automatically after three seconds.

Standby



If you do not wish to use the display lighting, this can be disabled.

- Press the 'child lock button + timer button' to disable the display.
 - 'Off' and the 'timer' pictogram will appear on the display.
- Press the 'child lock button + timer button' again to reactivate the display.

'On' and the 'timer' pictogram will appear on the display.



Following a power failure the additional function settings will only be saved for a few minutes. All settings, except the sound signal and child lock, will then revert to factory settings.

Culisensor

If the culisensor is plugged in, the culisensor screen will be shown and a small culisensor icon will appear. The oven operates until the food core reaches the set temperature. The core temperature is measured by means of the temperature probe.

1. Screw the metal cover from the connection point (front top corner of the right side wall).
2. Put the culisensor plug in the connection and insert the culisensor completely into the food.

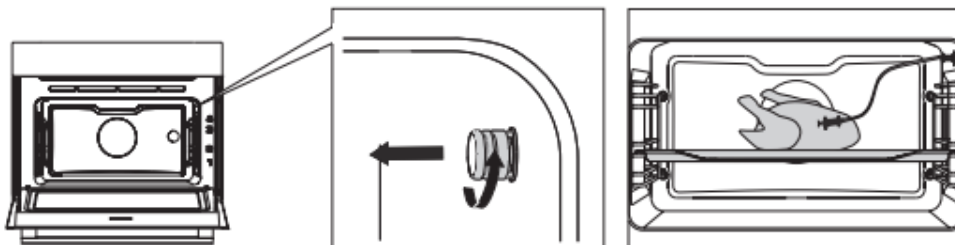

The display will show the culisensor screen and icon.

3. Set the function and temperature. Instead of the time, you need to set the core temperature (between 30 -100 °C).



4. Start the process by pressing the 'start/stop' button.

- During cooking, the rising temperature of the core will be displayed (the desired core temperature may be adjusted during the cooking process).
- When the set core temperature is reached, the cooking process will stop. An acoustic signal will sound, which you may turn off by pressing any button. After one minute, the acoustic signal will be switched off automatically. The current time appears on the display.



- **Always place the culisensor's entire metal sensor in the dish. Please note! After the cooking process always replace the metal cap on the culisensor's connection.**
- **Only use the culisensor in your oven.**
- **Ensure that the culisensor does not come into contact with the heating element during cooking.**
- **The culisensor will be extremely hot after the cooking process. Be careful! Avoid burns.**

Recommended core temperature values

Beef		
Fillet/sirloin	medium	55 - 58 °C
Roast beef	medium	55 - 60 °C
Round steak	well-done	85 - 90 °C
Roast beef	well-done	80 - 85 °C

CLEANING

Cleaning the oven

Clean the oven regularly to prevent fat and leftover food from accumulating, especially on interior and

Stewed beef	well-done	90 °C
• Pork		
Hoof/leg	well-done	75 °C
Hoof/leg	slightly pink	65 - 68 °C
Pork loin	slightly pink	65 - 70 °C
•		
Pork shoulder	well-done	75 °C
Pork belly/stuffed	well-done	75 - 80 °C
Pork belly	well-done	80 - 85 °C
Roast pork hoof	well-done	80 - 85 °C
• Pork hoof	well-done	80 - 85 °C
Cooked ham	very tender	64 - 68 °C
•		
Kassel ribs	well-done	65 °C
• Breaded ham		65 - 68 °C
Veal		
•		
• Veal loin	slightly pink	58 - 65 °C
Veal hoof/leg of veal	well-done	78 °C
Fried kidneys	well-done	75 - 80 °C
Roast veal/shoulder	well-done	75 - 80 °C

exterior surfaces,
the door and seal.

Clean exterior
surfaces with a
soft cloth and
soapy warm water.

Wipe afterwards
with a clean, damp
cloth and dry the
surfaces.

Remove splashes
and stains on the
interior surfaces
with a soapy
cloth. Wipe
afterwards with a
clean, damp cloth
and dry the
surfaces.

Clean the interior
of the oven

Important

Take care that NO
water enters the
vents.

NEVER use
abrasive cleaning
materials or
chemical solvents.

ALWAYS ensure
that the door seal
stays clean.

This prevents
accumulation of
dirt and allows you
to close the door
properly.

Leg of veal	well-done	75 - 78 °C
Mutton		
Mutton loin	pink	65 - 70 °C
Mutton loin •	well-done	80 °C
Mutton hoof	pink	70 - 75 °C
• Leg of mutton		82 - 85 °C
Lamb		
Leg of lamb	pink	60 - 62 °C
Leg of lamb	well-done	68 - 75 °C
Lamb loin	pink	54 - 58 °C
Lamb loin	well-done	68 - 75 °C
Lamb shoulder	well-done	78 - 85 °C
Poultry		
Chicken	well-done	85 °C
Goose/Duck	well-done	90 - 92 °C
Turkey	well-done	80 - 85 °C
Pastries etc		
Pastries		72 - 85 °C

Removing and cleaning the guide rails.

Only use conventional cleaners to clean the guides.

Remove the screws using a screwdriver.

Remove the guides from the holes in the back wall.



Terrines		60 - 70 °C
Fish		
Salmon	soft	60 °C
Fish fillet		62 - 65 °C
Entire fish		65 °C
Terrine		62 - 65 °C

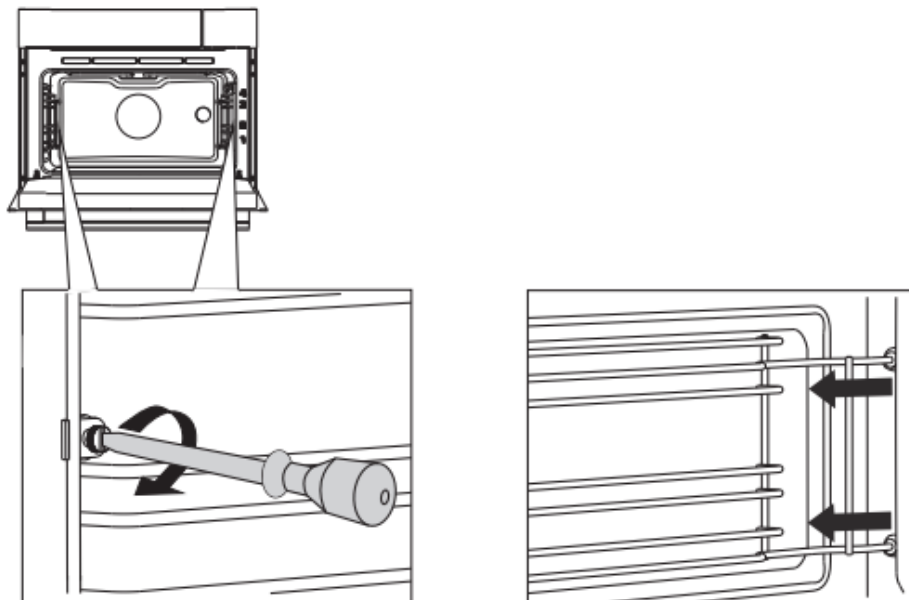

Removal and installation of the oven door

Keep your fingers away from the hinges of the oven door. The hinges are spring loaded and can cause injury if they spring back.

Make sure that the hinge latches are applied correctly to lock the hinges.

Remove the oven door

1. Open the door to the fully open position.
2. Lift both hinge latches (A) and pull them towards the oven door (B).

The hinges will be locked in the 45° position.

3. Gently close the door until it reaches a 45° angle.
4. Remove the door by lifting and tilting it towards the oven (C).

The hinges need to come out of the slots in the oven.

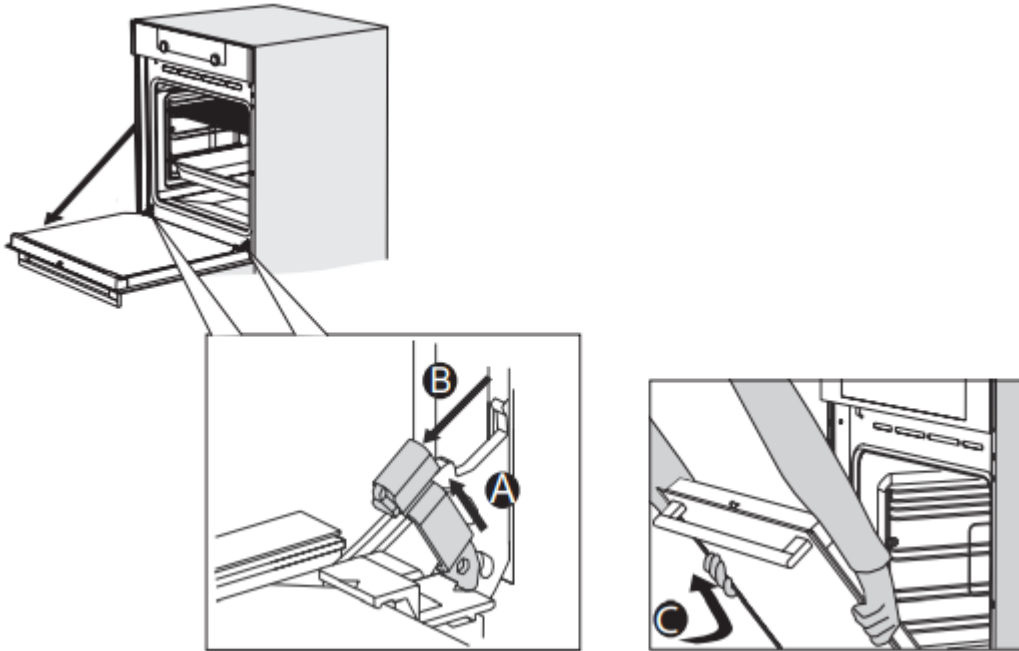

Install the oven door

1. Hold the door at an angle of approximately 45° in front of the oven.
2. Insert the hinges into the slots and make sure they are both positioned correctly.
3. Open the door to the fully open position.
4. Lift both hinge latches and move them towards the oven.
5. Gently close the oven door and make sure that it closes correctly.

If the door does not open or close correctly, then make sure that the hinges are positioned correctly in their slots.

Removing the oven window

The glass in the oven door can be cleaned from the inside, but you do need to remove the glass from the door to do this. First remove the oven door (see chapter 'Removing the oven door').

1. Lift the brackets on the left and right side of the door upwards slightly (to marker 1 on the bracket) and pull this away from the glass slightly (to marker 2 on the bracket).
2. Grasp the glass at the bottom and gently lift this upwards to remove it from the support.
3. The inner third glass (depending on the model) can be removed by lifting this carefully and removing it. Also remove the rubber seals around the glass.

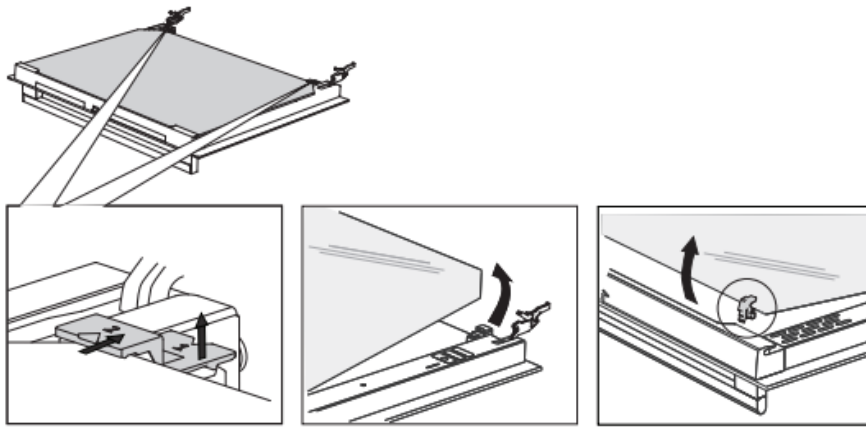

To replace the glass pane, observe the reverse order. The markings (semicircle) on the door and the glass pane should overlap.

The Cleaning function (pyrolysis)

Instead of cleaning manually, you can clean the oven space or an enamelled baking tray using the 'Pyrolysis' oven feature. During pyrolysis the oven space is heated to a very high temperature. Contaminants that are present incinerate at this high temperature and only ash remains.

With average use of the oven, we recommend running the pyrolysis function once per month.

Caution!

- First, remove all accessories and guide rails / telescopic guide rails from the oven (see 'Removing and cleaning the guide rails').
- Then remove any remaining food from the oven space and wipe the space with a damp cloth. Chunks of food and fat may ignite during the pyrolysis process. Fire hazard!

Note! The oven space and an enamelled baking tray cannot be cleaned at the same time using the pyrolysis function. If you want to clean an enamelled baking tray using pyrolysis, then do this first (the oven space can become dirty due to the cleaning of the baking tray). Insert one baking tray at a time. After that, the oven space can be cleaned.

Caution! Do NOT clean the glass baking tray using the 'Pyrolysis' oven feature.

Starting the Pyrolysis function



Pyrolysis

1. Make sure the oven space is completely empty and no chunks of food and fat are present!
2. If you want to clean an enamelled baking tray first, place the special pyrolysis guide rails in position. Wipe the baking tray with a damp cloth and slide the baking tray into the oven on Level 2.
 - Remove these special pyrolysis guide rails after the cleaning process.
3. Turn the 'oven function dial' to 'Pyrolysis'. The cleaning intensity level and time are displayed.
4. To choose the desired cleaning intensity level, press the 'temperature button' and turn the 'selection dial' to select one of three cleaning levels (one, two or three bars lit).
5. After a certain period of time, oven door will be automatically locked for your safety. The key symbol will appear on the display.
 - Unpleasant smell may be emitted from the oven during the cleaning process.
 - When the oven has cooled down, wipe it with a damp cloth. Wipe the oven door and the adjacent surfaces in the gasket area. Do not rub the gasket.

Please note: Do not attempt to open the oven door while the automatic cleaning programme is in progress. The programme may be terminated. Risk of burns!

Replacing the oven lamp

The lamp in this household appliance is only suitable for illumination of this appliance. The lamp is not suitable for household room illumination.

The lamp (E14, 230-240 V, 25 W, 300 °C) is a consumer item and therefore does not fall under the guarantee. First remove the baking tray, oven rack and guide rails.

Cut the power to the appliance by removing the plug from the socket or switching off the fuse in the fuse box!

Please note: the lamp can be very hot! Use protection to remove the lamp.

Rear wall lamp

1. Turn the cover to the left to remove it.

2. Turn the bulb out of the fitting.

Side wall lamp

1. Use a flat-blade screwdriver to snap and remove the lamp cover from the holder.

Be careful not to damage the enamel.

2. Turn the bulb out of the fitting.

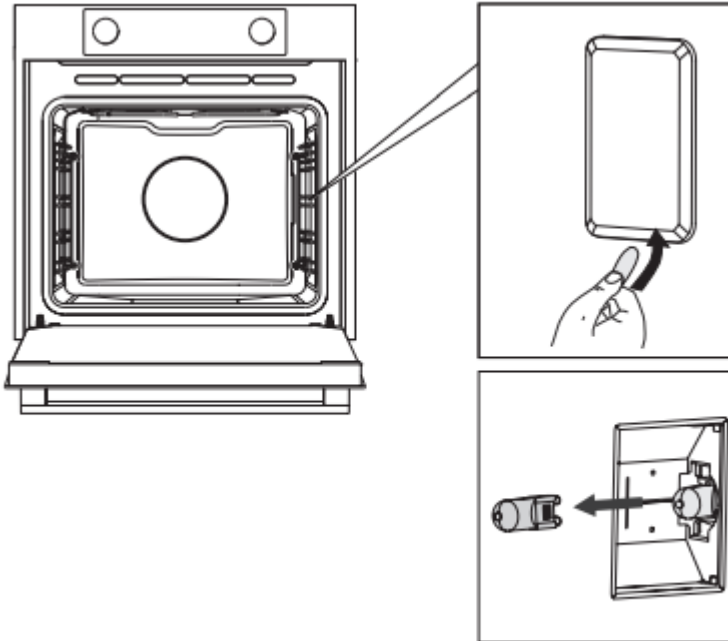

SOLVING PROBLEMS

General

Try the solutions below if you have problems with your oven. You could save yourself the time and effort of an unnecessary phone call to customer services.

The food is not cooked

- Check whether the timer has been set and you have pressed the 'start button'.
- Close the door properly.
- Check whether a fuse has blown and whether a circuit breaker has been activated.

Food is overcooked or undercooked

- Check whether the correct cooking time has been set.
- Check whether the temperature has been set.

The display will be reset following power failure

- Remove the plug from the socket and put it back in again.

- Set the time again.

There is condensation on the interior of the oven

- This is normal. Wipe the oven clean after use.

The fan keeps working after the oven is switched off

- This is normal. Once the oven has been switched off, the cooling fan may continue to run for a little while.

Air flow can be felt at the door and the exterior of the appliance

- This is normal.

Light reflects on the door and the exterior of the appliance

- This is normal.

Steam escapes from the door or the vents

- This is normal.

Clicking sounds can be heard when the oven is working, particularly in the defrost setting

- This is normal.

Storing and repairing the oven

Repairs may only be performed by a qualified service technician.

If maintenance is required, remove the plug from the socket and contact ASKO customer services.

Have the following information to hand when you call:

- The model number and serial number (stated on the inside of the oven door)
- Guarantee details
- A clear description of the problem

Choose a clean, dry place if you have to store the oven temporarily, as dust and moisture can damage the appliance.

YOUR OVEN AND THE ENVIRONMENT

Disposal of the appliance and packaging

This product is manufactured from sustainable materials. However, the appliance must be disposed of responsibly at the end of its useful life. The government can provide you with information about this.

The appliance packaging is recyclable. The following materials have been used:

- cardboard
- polyethylene wrapping (PE)

- CFC-free polystyrene (hard PS foam)

Dispose of these materials responsibly in accordance with legal provisions.



The product has a pictogram of a rubbish bin with a cross through it. This indicates that household appliances must be disposed of separately. This means that the appliance may not be processed via the regular waste flow at the end of its useful life. You should take it to a special municipal waste depot or a sales outlet that offers to do this for you.

Collecting household equipment separately prevents harm to the environment and public health. The materials used in manufacturing this appliance can be recycled, which provides considerable savings in energy and raw materials.

Declaration of conformity



We hereby declare that our products comply with the relevant European directives, standards and regulations as well as all requirements referred to in the standards.

COOKING TEST

Food tested in compliance with the EN 60350-1 standard

Baking					
Dish	Equipment	Guide (from the bottom)	Temperature (°C)	Cooking time (min)	System
Shortbread - single level	Shallow enamel-coated baking tray	3	140-150 *	20-35	Ⓜ

Shortbread - single level	Shallow enamel-coated baking tray	3	140-150 *	25-40	—
Shortbread - two levels	Shallow enamel-coated baking tray	2, 3	140-150 *	25-40	⌚
Shortbread - three levels	Shallow enamel-coated baking tray	2, 3, 4	130-140 *	30-50	⌚
Cupcakes - single level	Shallow enamel-coated baking tray	3	140-150 *	20-35	⌚
Cupcakes - single level	Shallow enamel-coated baking tray	3	150-160 *	20-35	—
Cupcakes - two levels	Shallow enamel-coated baking tray	1, 3	140-150 *	30-45	⌚
Cupcakes - three levels	Shallow enamel-coated baking sheet	2, 3, 4	140-150 *	35-50	⌚

* Preheat for 10 minutes. Do not use fast preheat function.



Sponge cake	Round metal mould, diameter 26 cm/Oven rack	2	160-170 *	20-35	☐
Sponge cake	Round metal mould, diameter 26 cm/Oven rack	2	160-170 *	20-35	☐
Apple pie	2 x round metal mould, diameter 20 cm/Oven rack	2	170-180	65-85	☐
Apple pie	2 x round metal mould, diameter 20 cm/Oven rack	3	160-170	65-85	☐
Grilling					
Dish	Equipment	Guide (from the bottom)	Temperature (°C)	Cooking time (min)	System
Toast	Oven rack	5	240	3:00-6:00	☐
Beefburgers	Oven rack + baking sheet as drip tray	5	240	25-35 **	☐

** Turn after 2/3 of the cooking time.

Warning

This content is compiled from multiple sources and is provided for reference purposes only. It may not be complete or fully applicable to all situations. If you are unable to resolve your issue, please contact the product manufacturer or an authorized service provider for official support.

Document generated by [ManualsFile](#)

