

INSTALLATION INSTRUCTIONS

Unpack the Refrigerator

Remove the Packaging

- Remove tape and glue residue from surfaces before turning on the refrigerator. Rub a small amount of liquid dish soap over the adhesive with your fingers. Wipe with warm water and dry
- Dispose of/recycle all packaging materials.

Clean Before Using

After you remove all of the package materials, clean the inside of your refrigerator before using it. See the cleaning instructions in "Refrigerator Care."

Location Requirements

IMPORTANT: This refrigerator is designed for indoor, household use only.

To ensure proper ventilation for your refrigerator, it is recommended to allow a ½" (1.25 cm) space on each side. Allow 3" (7.5 cm) of space between overhead cabinets and refrigerator top. Allow at least 1" (2.5 cm) between back of cabinet and the wall. If your refrigerator has an ice maker, make sure you leave some extra space at the back for the water line connections.

- If you are installing your refrigerator next to a fixed wall, leave enough space on the hinge side to allow for the door to swing open.
- Level the refrigerator. See "Adjust the Doors."

NOTE: This refrigerator is intended for use in a location where the temperature ranges from a minimum of 55°F (13°C) to a maximum of 110°F (43°C). The preferred room temperature range for optimum performance, which reduces electricity usage and provides superior cooling, is between 60°F (15°C) and 90°F (32°C). It is recommended that you do not install the refrigerator near a heat source, such as an oven or radiator.

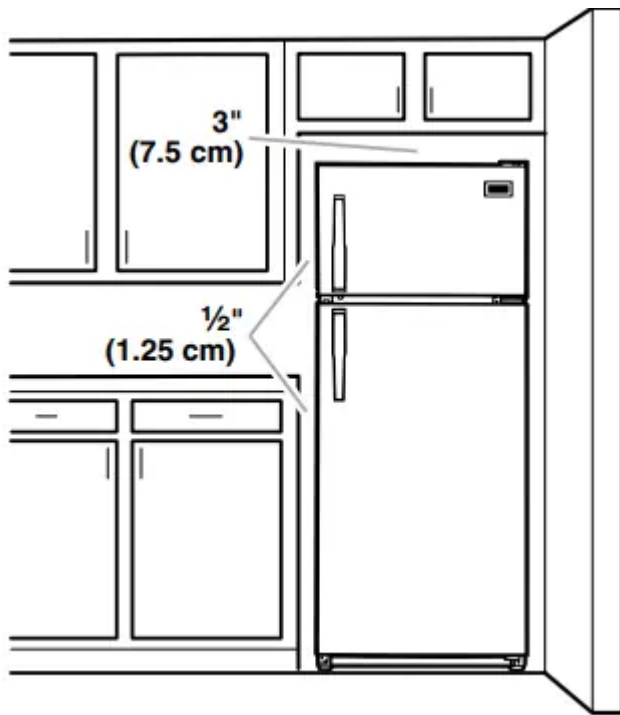

Electrical Requirements

Before you move your refrigerator into its final location, it is important to make sure you have the proper electrical connection.

Recommended Grounding Method

A 115 volt, 60 Hz, AC only, 15- or 20-amp fused, grounded electrical supply is required. It is recommended that a separate circuit serving only your refrigerator be provided. Use an outlet that cannot be turned off by a switch. Do not use an extension cord.

NOTE: Before performing any type of installation or cleaning, or removing a light bulb, turn cooling off or turn the control (Thermostat, Refrigerator or Freezer Control depending on the model) to OFF, and then disconnect the refrigerator from the electrical source. When you are finished, reconnect the refrigerator to the electrical source and turn cooling on or reset the control (Thermostat, Refrigerator or Freezer Control depending on the model) to the desired setting. See “Using the Controls” in the User Instructions, User Guide, or Use & Care Guide.

Water Supply Requirements

Read all directions before you begin. Gather the required tools and parts before starting installation. Read and follow the instructions provided with any tools listed here.

TOOLS NEEDED: Flat-blade screwdriver, $\frac{7}{16}$ " and $\frac{1}{2}$ " open-end wrenches or 2 adjustable wrenches, $\frac{1}{4}$ " nut driver and drill bit, cordless drill.

IMPORTANT:

- If you turn the refrigerator on before the water line is connected, turn the ice maker OFF.
- All installations must meet local plumbing code requirements.
- Use copper tubing and check for leaks. Install copper tubing only in areas where the household temperatures will remain above freezing.

NOTE: Your refrigerator dealer has a kit available with a ¼" (6.35 mm) saddle-type shutoff valve, a union, and copper tubing. Before purchasing, make sure a saddle-type valve complies with your local plumbing codes. Do not use a piercing-type or ⅜" (4.76 mm) saddle valve which reduces water flow and clogs more easily

Water Pressure

IMPORTANT: A cold water supply with water pressure between 30 and 120 psi (207 and 827 kPa) is required to operate the ice maker.

NOTE: If the water pressure is less than what is required, ice cubes could be hollow or irregular shaped.

If you have questions about your water pressure, call a licensed, qualified plumber.

Reverse Osmosis Water Supply

If a reverse osmosis water filtration system is connected to your cold water supply, the water pressure to the reverse osmosis system needs to be a minimum of 40 to 60 psi (276 to 414 kPa). If the ice maker is still not operating properly:

- Check to see whether the sediment filter in the reverse osmosis system is blocked. Replace the filter if necessary.
- Allow the storage tank on the reverse osmosis system to refill after heavy usage.

Connect the Water Supply (on some models)

Connect to Water Line

1. Unplug refrigerator or disconnect power.
2. Turn OFF main water supply. Turn ON nearest faucet long enough to clear line of water.
3. Locate a ½" to 1¼" (1.27 cm to 3.18 cm) vertical cold water pipe near the refrigerator
4. Determine the length of copper tubing you will need. Measure from the connection on lower left rear of refrigerator to the water pipe. Add 7 ft (2.1 m) to

allow for cleaning. Use ¼" (6.35 mm) O.D. (outside diameter) copper tubing. Be sure both ends of copper tubing are cut square.

5. Using a cordless drill, drill a ¼" hole in the cold water pipe you have selected.

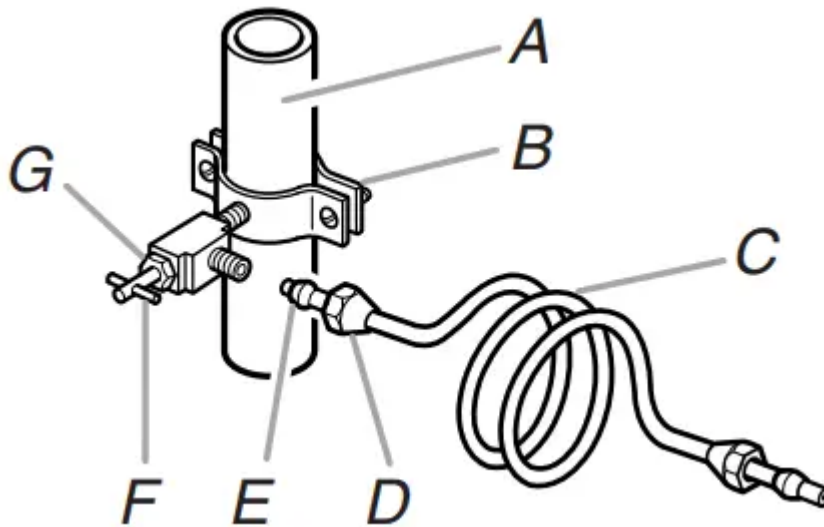

- A. Cold water pipe
- B. Pipe clamp
- C. Copper tubing
- D. Compression nut
- E. Compression sleeve
- F. Shutoff valve
- G. Packing nut

6. Fasten the shutoff valve to the cold water pipe with the pipe clamp. Be sure the outlet end is solidly in the ¼" drilled hole in the water pipe and that the washer is under the pipe clamp. Tighten the packing nut. Tighten the pipe clamp screws slowly and evenly so washer makes a watertight seal. Do not overtighten.

7. Slip the compression sleeve and compression nut on the copper tubing as shown. Insert the end of the tubing into the outlet end squarely as far as it will go. Screw compression nut onto outlet end with adjustable wrench. Do not overtighten.

8. Place the free end of the tubing in a container or sink, and turn ON the main water supply. Flush the tubing until water is clear. Turn OFF the shutoff valve on the water pipe. Coil the copper tubing.

Connect to Refrigerator

Style 1

1. Unplug refrigerator or disconnect power.
2. Attach the copper tube to the valve inlet using a compression nut and sleeve as shown. Tighten the compression nut. Do not overtighten.
3. Use the tube clamp on the back of the refrigerator to secure the tubing to the refrigerator as shown. This will help avoid damage to the tubing when the refrigerator is pushed back against the wall.
4. Turn shutoff valve ON.
5. Check for leaks. Tighten any connections (including connections at the valve) or nuts that leak.

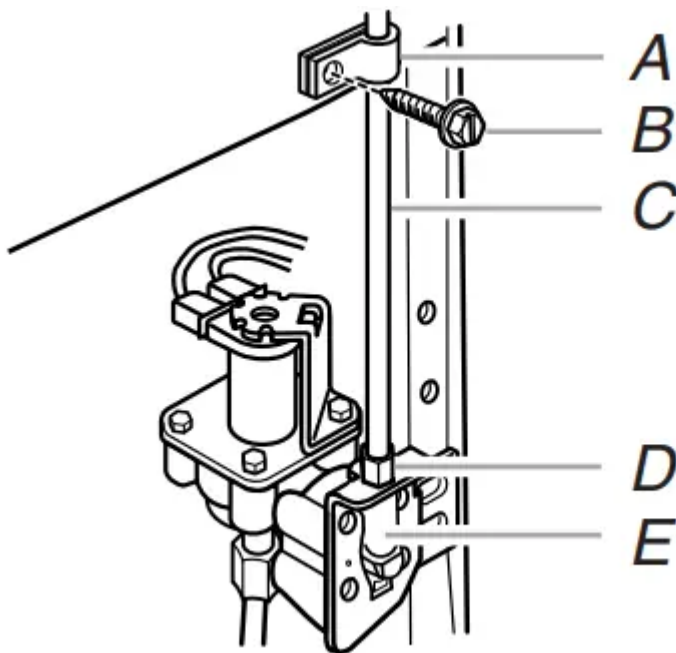

- A. Tube clamp
- B. Tube clamp screw
- C. Copper tubing
- D. Compression nut
- E. Valve inlet

6. The ice maker is equipped with a built-in water strainer. If your water conditions require a second water strainer, install it in the $\frac{1}{4}$ " (6.35 mm) water line at either tube connection. Obtain a water strainer from your nearest appliance dealer.

Style 2

1. Unplug refrigerator or disconnect power.

2. Disconnect the tube clamp on the back of the product and insert the copper tubing through the clamp as shown.
3. Attach the copper tube to the valve inlet using a compression nut and sleeve as shown.
4. Tighten the compression nut. Do not overtighten. Reattach the tube clamp and tube to the back of the cabinet.

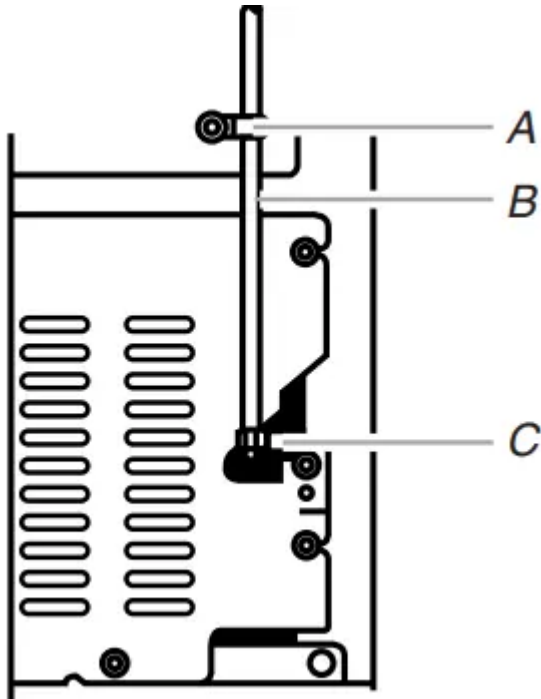

- A. Tube clamp
- B. Copper tubing
- C. Compression nut

5. Turn shutoff valve ON. Check for leaks. Tighten any connections (including connections at the valve) or nuts that leak.
6. The ice maker is equipped with a built-in water strainer. If your water conditions require a second water strainer, install it in the $\frac{1}{4}$ " (6.35 mm) water line at either tube connection. Obtain a water strainer from your nearest appliance dealer.

Complete the Installation

1. Plug into a grounded 3 prong outlet.

NOTE: Allow 24 hours to produce the first batch of ice. Discard the first three batches of ice produced. Allow 3 days to completely fill ice container

Refrigerator Doors

TOOLS NEEDED:

- $\frac{5}{16}$ " hex head socket wrench
- $\frac{5}{16}$ " open-end wrench
- #2 Phillips screwdriver
- flat 2" putty knife
- Flat-blade screwdriver

IMPORTANT :

- Before you begin, turn the refrigerator control OFF. Unplug refrigerator or disconnect power.
- Remove food and adjustable door or utility bins from doors.
- If you are only removing and replacing the doors, see the "Remove Doors and Hinges" and "Replace Doors and Hinges" sections.
- Depending on your model, you may have standard (Style 1) or contoured (Style 2) doors. If you are also going to reverse the door swing, follow the instructions for the appropriate door style.
- All graphics referenced in the following instructions are included later in this section after "Final Steps."

Remove Doors and Hinges



$\frac{5}{16}$ " Hex Head Hinge Screw

1. Unplug refrigerator or disconnect power.
2. Close the refrigerator door and keep both doors closed until you are ready to lift them free from the cabinet. NOTE: Provide additional support for the doors while the hinges are being moved. Do not depend on the door magnets to hold the doors in place while you are working.
3. Remove the parts for the top hinge as shown in Top Hinge graphic. Lift the freezer door free from the cabinet.
4. Remove the parts for the center hinge as shown in the Center Hinge graphic. Lift the refrigerator door free from the cabinet.
5. Remove the parts for the bottom hinge as shown in the Bottom Hinge graphic.

Reverse Doors (optional)

IMPORTANT: If you want to reverse your doors so that they open in the opposite direction, follow these steps. If you are not reversing the doors, see “Replace Doors and Hinges.”

Style 1 - Standard

Graphics follow these instructions.



Door Stop Screw



Door Handle Sealing Screw



Flat-Head Handle Screw



Dome Cap

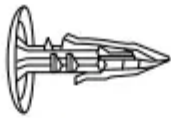

Door Handle Hole Plug



Door Hinge Hole Plug

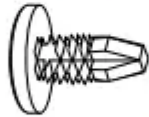

Cabinet Hinge Hole Plug



Dome Cap Washer

Cabinet

1. Remove $\frac{5}{16}$ " hex head hinge screws from handle side and move them to opposite side. See Graphic 1-1.
2. Remove cabinet hinge hole plugs from cabinet top and move them to opposite side hinge holes as shown. See Graphic 1-2.

Freezer door

1. Remove the screw cover. See Graphic 2.
2. Remove the freezer handle assembly as shown. Keep all parts together. See Graphic 2.
3. Remove door hinge hole plug from freezer door. Move to opposite side hinge hole as shown. See Graphic 3.
4. Remove the brand badge. Replace it with the badge provided in the Reversibility Kit located inside the crisper. For proper placement, see the Brand Badge Placement template (the last page of this manual).
5. Remove door stop. Move to opposite side of refrigerator door as shown. See Graphic 5.
6. Position freezer handle on opposite side of the freezer door as shown. See Graphic 2. First, drive the bottom two screws into handle. Align upper portion of handle and drive top screw into handle.

7. Replace screw cover. See Graphic 2.
8. Tighten all screws. Set aside door until hinges and refrigerator compartment door are in place.

Refrigerator door

1. Remove the screw cover. See Graphic 6.
2. Remove refrigerator handle assembly as shown. Keep all parts together. See Graphic 6.
3. Remove door hinge hole plug from refrigerator door. Move to opposite side hinge hole as shown. See Graphic 3.
4. Remove door handle sealing screws. Move to opposite side of refrigerator door as shown. See Graphic 4.
5. Remove door handle hole plug, see Graphic 7. Replace with the door handle hole plug provided in the Reversibility Kit located in the crisper.
6. Remove door stop. Move to opposite side of refrigerator door as shown. See Graphic 5.
7. Position refrigerator handle on opposite side of the refrigerator door as shown. See Graphic 6. First, drive top two screws in handle first. Align lower portion of handle and drive bottom screw into handle.
8. Replace screw cover. See Graphic 6.
9. Tighten all screws. Set aside refrigerator door until bottom hinge is installed on refrigerator.

Style 2 - Contoured

Graphics follow these instructions.



Cabinet

1. Remove $\frac{5}{16}$ " hex head hinge screws from handle side and move them to opposite side. See Graphic 1-1.

2. Remove cabinet hinge hole plugs from the cabinet top and move them to opposite side hinge holes as shown. See Graphic 1-2.

Doors

1. Remove door hinge hole plug from top of freezer door. Move to opposite side as shown. See Graphic 2.
2. Remove door stop from both the freezer and refrigerator doors and move to the other side. See Graphic 3.

Replace Doors and Hinges

1. Replace the parts for the bottom hinge as shown. Tighten screws. Replace the refrigerator door.
2. Assemble the parts for the center hinge as shown and tighten all screws. See Center Hinge graphic. Replace the freezer door.
3. Assemble the parts for the top hinge as shown. See Top Hinge graphic. Do not tighten screws completely.
4. Line up the doors so that the bottom of the freezer door aligns evenly with the top of the refrigerator door. Tighten all screws.

Final Steps

1. Check all holes to make sure that hole plugs and screws are in place. Reinstall top hinge cover. See Top Hinge graphic.
2. Plug into a grounded 3 prong outlet.
3. Reset the controls. See "Using the Control(s)."
4. Return all removable door parts to doors and food to refrigerator.

Style 1 - Standard

Door Removal & Replacement

Top Hinge

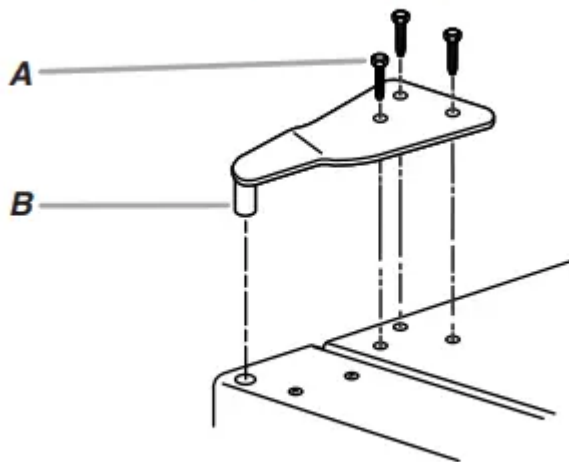

- A. $\frac{5}{16}$ " Hex-Head Hinge Screws
- B. Top Hinge

Center Hinge

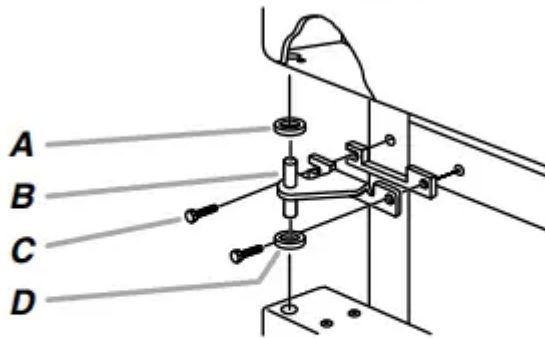

- A. Spacer
- B. Center Hinge
- C. $\frac{5}{16}$ " Hex-Head Hinge Screws
- D. Spacer

Bottom Hinge

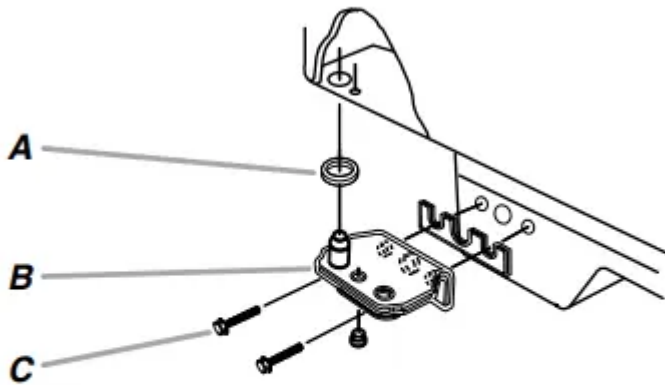

- A. Spacer
- B. Bottom Hinge
- C. $\frac{5}{16}$ " Hex-Head Hinge Screws

Door Swing Reversal (optional)

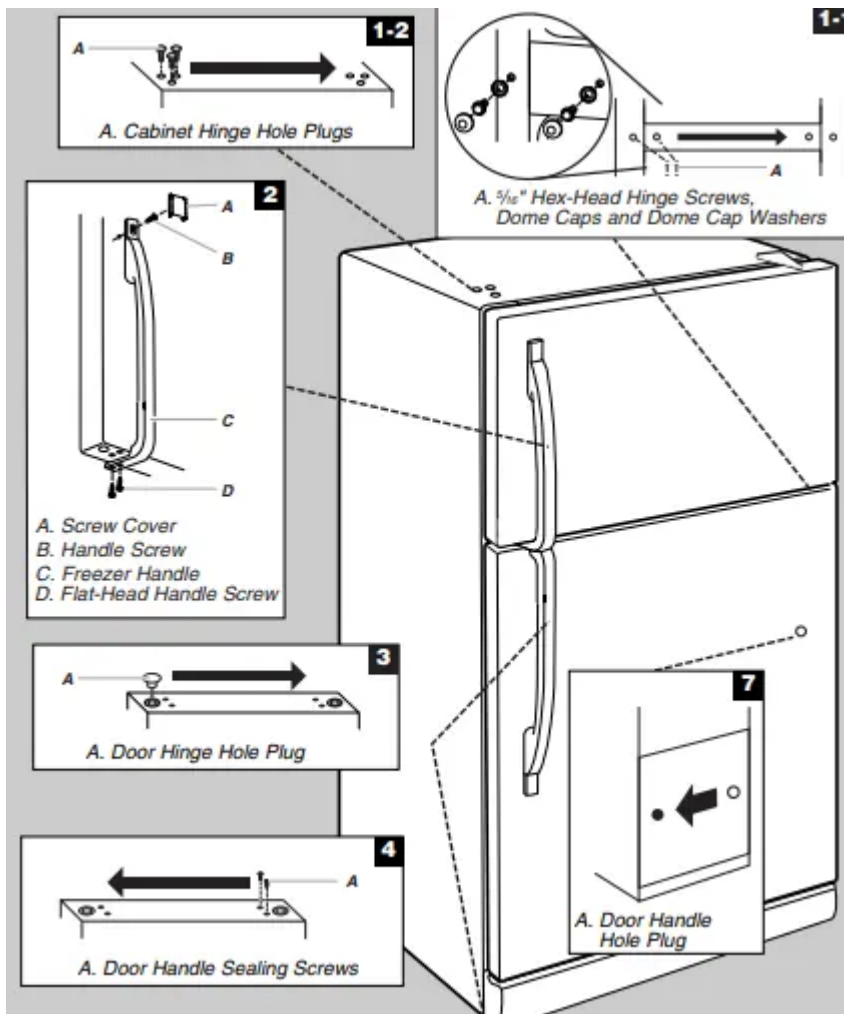

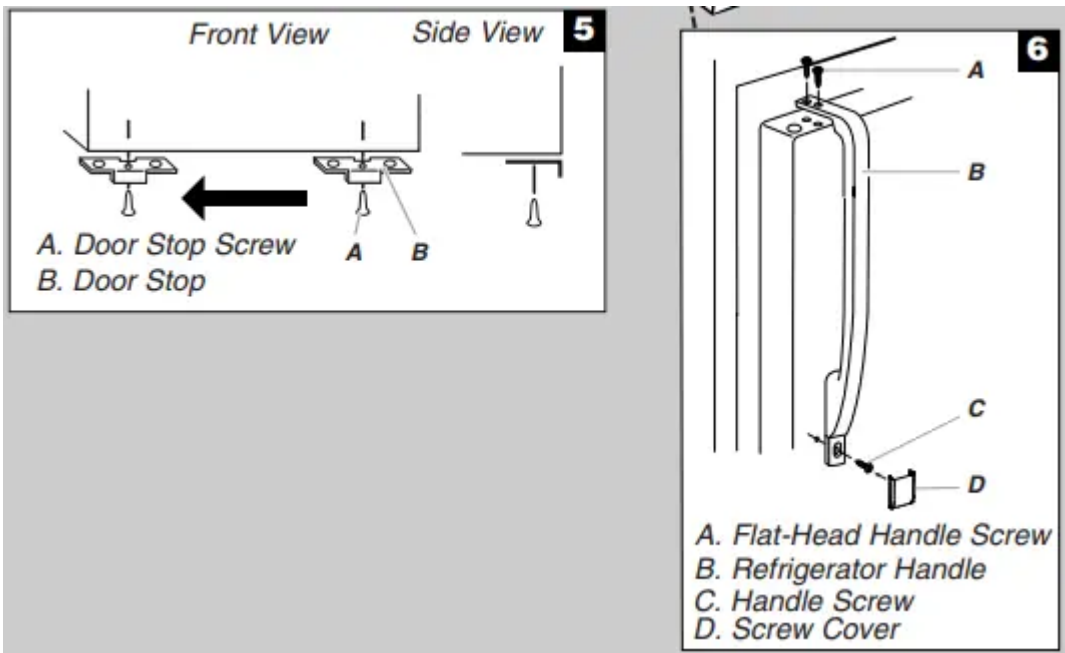

Style 2 - Contour

Door Removal & Replacement

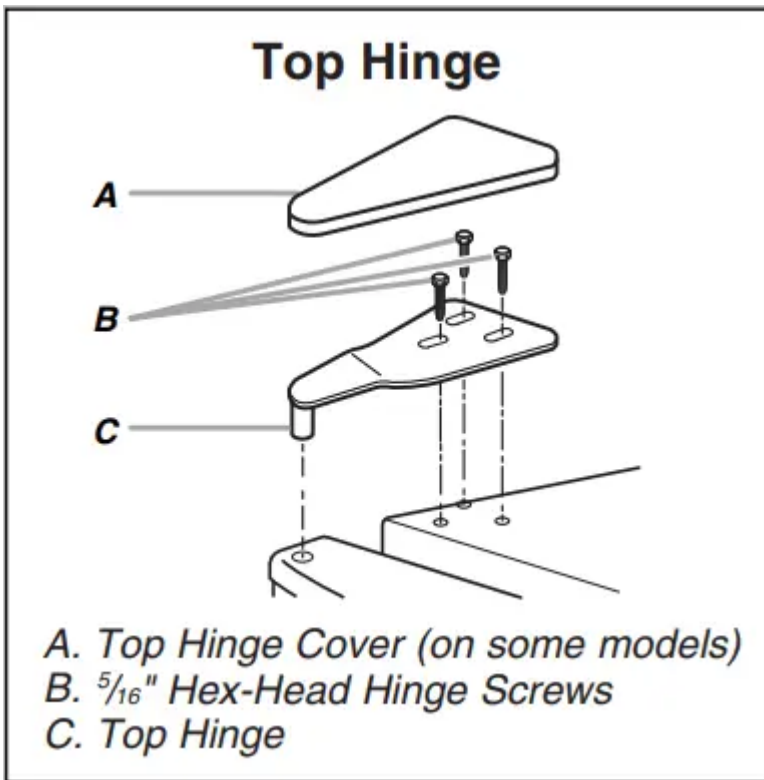

Center Hinge

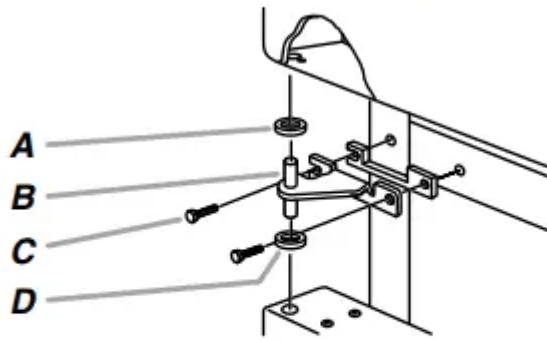

- A. *Spacer*
- B. *Center Hinge*
- C. *$\frac{5}{16}$ " Hex-Head Hinge Screws*
- D. *Spacer*

Bottom Hinge

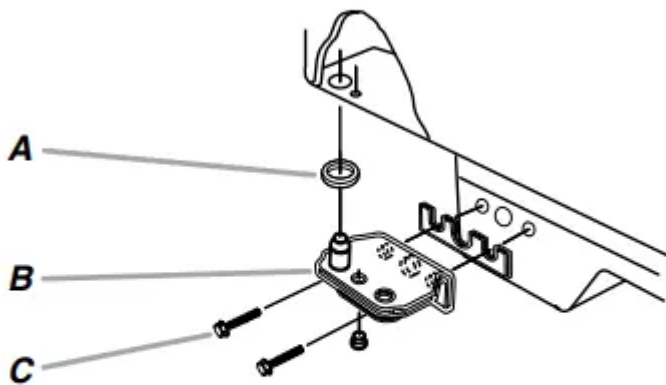

- A. *Spacer*
- B. *Bottom Hinge*
- C. *$\frac{5}{16}$ " Hex-Head Hinge Screws*

Door Swing Reversal (optional)

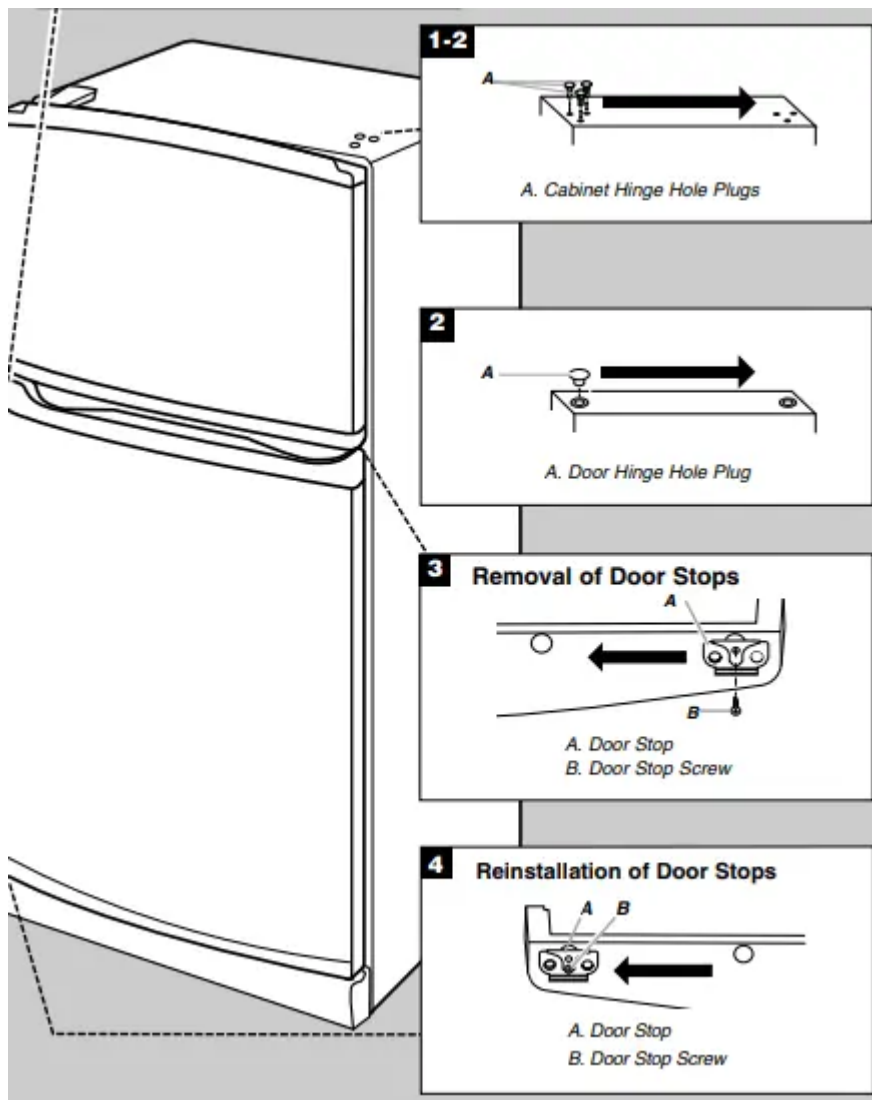
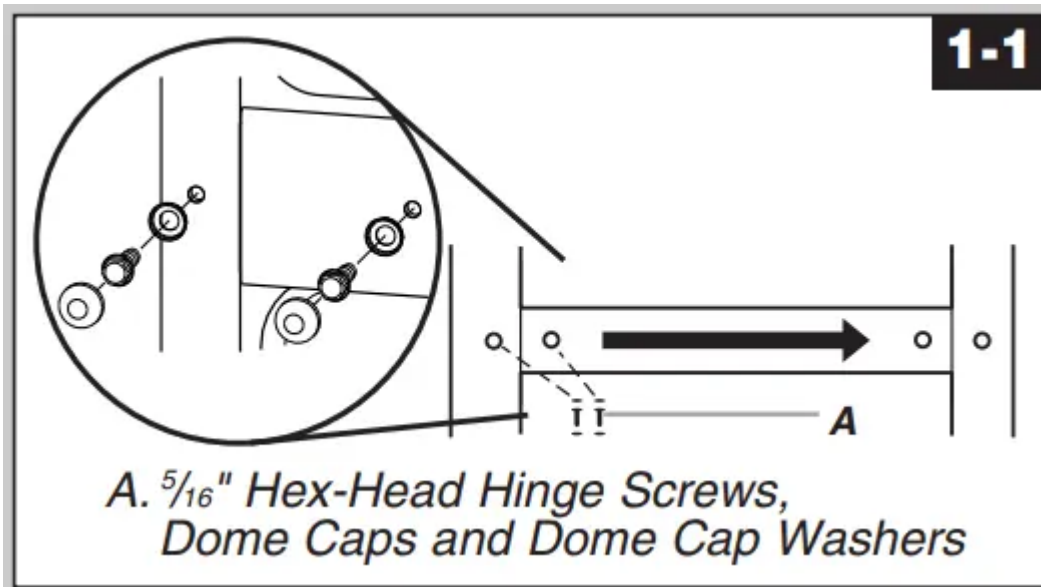

Adjust the Doors

Your refrigerator has two adjustable rollers - one on the right and one on the left. If your refrigerator seems unsteady or you want the doors to close easier, adjust the refrigerator's tilt using the instructions below.

1. Turn the leveling leg to lower or raise that side of the refrigerator. It may take several turns to adjust the tilt of the refrigerator.

- To raise, turn the leveling leg to the left.
- To lower, turn the leveling leg to the right.

NOTE: Having someone push against the top of the refrigerator takes some weight off the leveling legs and rollers which makes it easier to adjust.

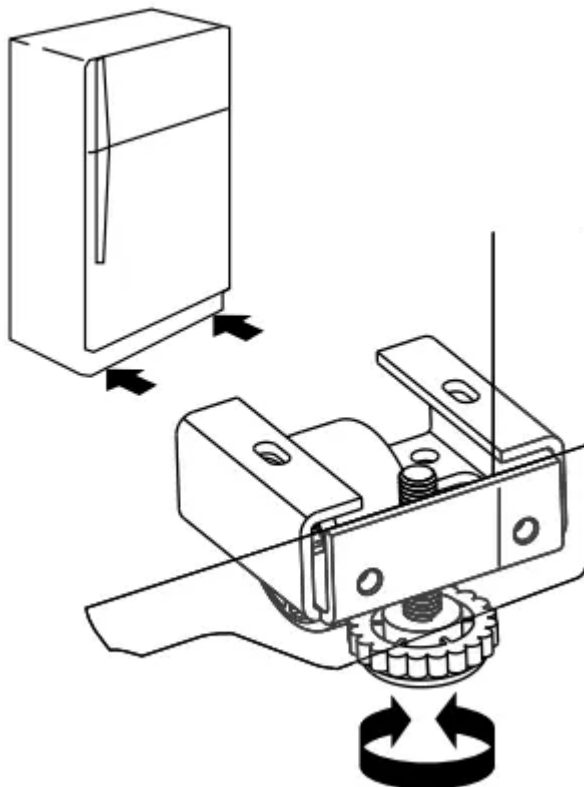

2. Open both doors again to make sure they close as easily as you like. If not, tilt the refrigerator slightly more to the rear by turning both leveling legs to the left; it may take several more turns.

NOTE: To keep the refrigerator level you should turn both leveling legs the same amount.

3. Using a level, be sure that the refrigerator is still level side to side. Readjust if necessary

REFRIGERATOR USE

Using the Controls

Your refrigerator has two controls that affect the temperature. The Temperature control is located at the top front of the refrigerator compartment and the Air Flow control is located on the back wall of the freezer compartment.

Temperature Control

The Temperature control regulates the coldness of the air flowing into the compartments. For your convenience, your refrigerator controls are preset at the factory. When you first install your refrigerator, make sure that the controls are still preset to the mid-setting as shown. NOTE: To turn your refrigerator off, turn the refrigerator control to the word OFF. Turning the Temperature Control to OFF stops cooling in the refrigerator and freezer compartments, but it does not disconnect the refrigerator from the power supply.

Mid-setting “3”

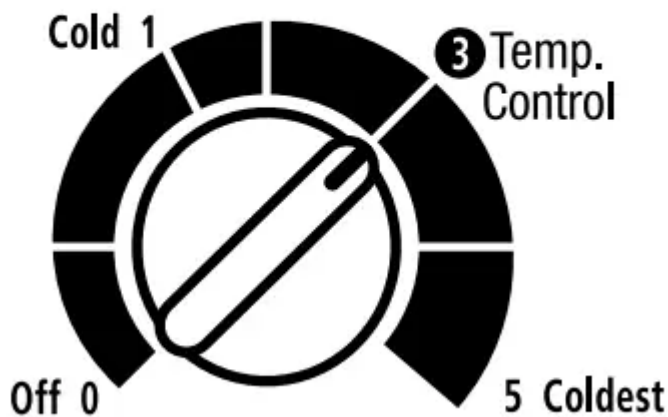

Adjust the Temperature Control

The mid-settings should be correct for normal household usage. The controls are set correctly when milk or juice is as cold as you like and when ice cream is firm. If the temperature is too warm or too cold in the refrigerator or freezer, first check the air vents to be sure they are not blocked. If you need to adjust temperatures, use the settings listed in the chart below as a guide. On models with two controls, adjust the refrigerator temperature first. Wait at least 24 hours between adjustments and then recheck the temperatures.

REFRIGERATOR section too warm

- Door opened often, large amount of food added or room temperature very warm
- Adjust REFRIGERATOR Control one setting higher

FREEZER section too warm/ice not made fast enough

- Door opened often, or large amount of food added or very cold room temperature (can't cycle often enough)

- Heavy ice usage

→ Adjust AIR FLOW or REFRIGERATOR Control one setting higher

REFRIGERATOR section too cold

- Controls not set correctly for your conditions

→ Adjust REFRIGERATOR Control one setting lower

Adjust REFRIGERATOR Control one setting lower

- Controls not set correctly for your conditions

→ Adjust AIR FLOW or REFRIGERATOR Control one setting lower

Air Flow Control

The Air Flow control regulates the amount of air flowing between the freezer and the refrigerator compartments. When you plug in the refrigerator for the first time, turn the Air Flow control to the Recommended setting.

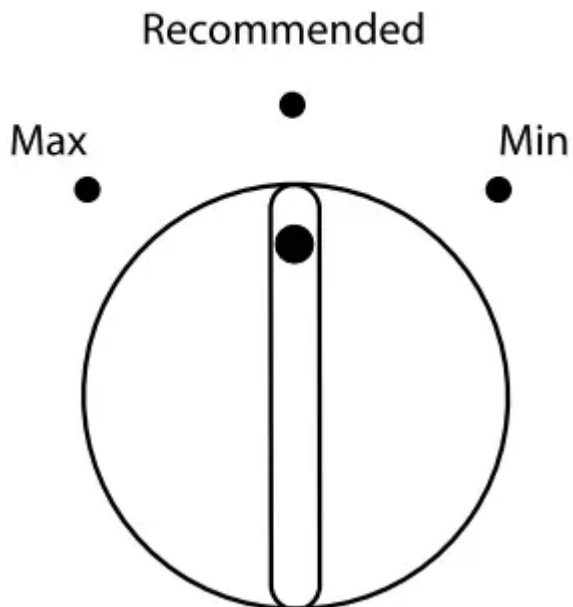

Adjust the Air Flow Control

If you want to temporarily increase the cold air flow to a specific compartment, adjust the control.

- Max - Increase air flow to the freezer
- Min - Increase air flow to the refrigerator

IMPORTANT: Once the performance is achieved, return the Air Flow control to the Recommended setting to keep the refrigerator operating at optimum efficiency.

Heavy ice use : Max

Hot room temperature : Max - To maintain ice making production rate

Large quantity of groceries : Min - To quickly chill food and beverages

Ice Maker (on some models - Accessory)

Turning the Ice Maker On/Off

NOTE: Do not force the wire shutoff arm up or down.

- To turn the ice maker on, simply lower the wire shutoff arm. **NOTE:** Your ice maker has an automatic shutoff. As ice is made, the ice cubes will fill the ice storage bin and the ice cubes will raise the wire shutoff arm to the OFF (arm up) position.
- To manually turn the ice maker off, lift the wire shutoff arm to the OFF (arm up) position and listen for the click to make sure the ice maker will not continue to operate.

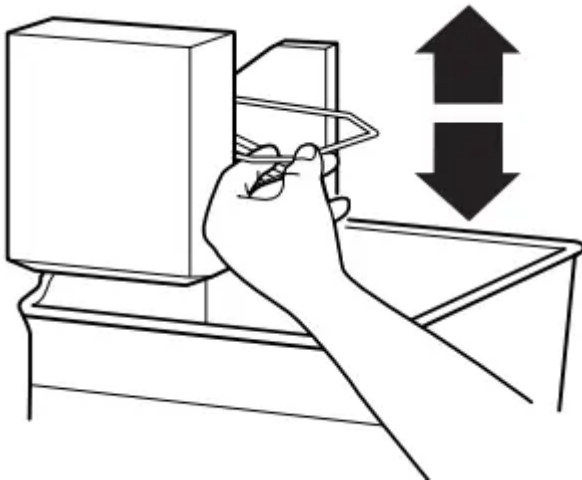

Ice Production Rate

- **NORMAL Ice Production:** The ice maker should produce approximately 8 to 12 batches of ice in a 24-hour period. If ice is not being made fast enough, turn the Freezer Control toward a higher (colder) number in half number steps. (For example, if the control is at 3, move it to between 3 and 4.) Wait 24 hours and, if necessary, gradually turn the Freezer Control to the highest setting, waiting 24 hours between each increase.

- **MAXIMUM Ice Production** (on some models): The ice maker should produce approximately 16 to 20 batches of ice in a 24-hour period. If your refrigerator has the maximum ice production feature, push the switch to MAX.

Remember

- Allow 24 hours to produce the first batch of ice. Allow 3 days to completely fill the ice storage bin. Discard the first three batches of ice produced.
- The quality of your ice will be only as good as the quality of the water supplied to your ice maker. Avoid connecting the ice maker to a softened water supply. Water softener chemicals (such as salt) can damage parts of the ice maker and lead to poor quality ice. If a softened water supply cannot be avoided, make sure the water softener is operating properly and is well maintained.
- Do not store anything on top of the ice maker or in the ice storage bin.

REFRIGERATOR FEATURES

Refrigerator Shelves (Glass shelves on some models)

The shelves in your refrigerator are adjustable to match your individual storage needs. Storing similar food items together in your refrigerator and adjusting the shelves to fit different heights of items will make finding the exact item you want easier. It will also reduce the amount of time the refrigerator door is open, and save energy.

Shelves and Glass Shelves (on some models)

To remove and replace a shelf:

1. Remove items from the shelf.
2. Slide the shelf straight out to the stop.
3. Depending on your model, lift back or front of the shelf past the stop. Slide shelf out the rest of the way.
4. Replace the shelf by sliding the back of the shelf into the track in the wall of the cabinet.
5. Guide the front of the shelf into the shelf track. Be sure to slide the shelf in all the way

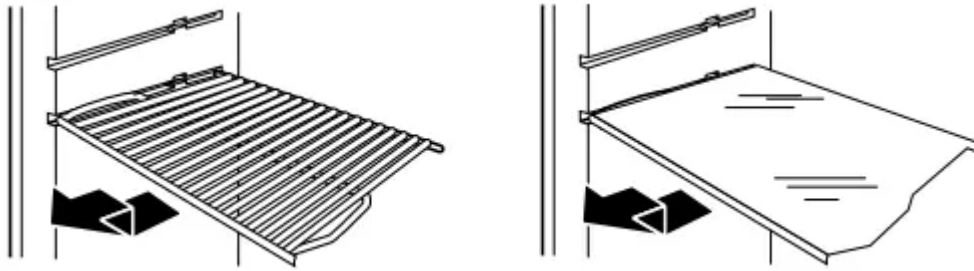

Deli Drawer (on some models)

To remove and replace the deli drawer:

1. Slide deli drawer out to the stop.
2. Lift front of deli drawer with one hand while supporting bottom of drawer with other hand. Slide drawer out the rest of the way.
3. Replace the drawer by sliding it back in fully past the drawer stop

Deli Drawer Cover (on some models)

To remove and replace the deli drawer cover:

1. Remove the deli drawer.
2. Push the cover back to release the rear clips from the shelf. Tilt the cover up at the front, and pull it forward.
3. Replace the deli drawer cover by fitting the notches and clips on the cover over the rear and center crossbars on the shelf.
4. Lower cover into place and pull the cover forward to secure the rear clips onto the shelf.
5. Replace the deli drawer. NOTE: In some models the deli drawer moves sideways on the shelf to allow for flexible positioning.

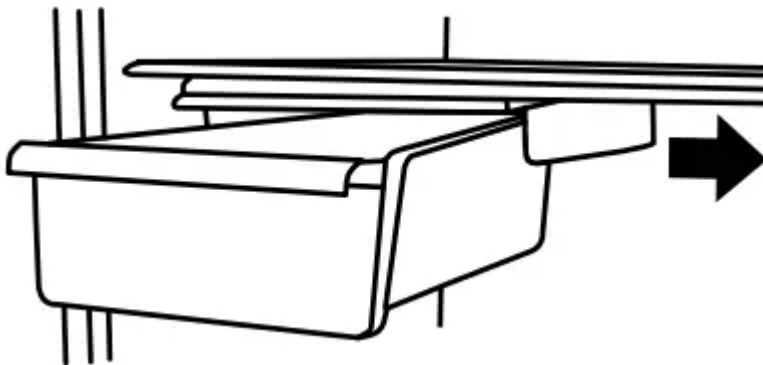

Meat Storage Guide

Store most meat in original wrapping as long as it is airtight and moisture-proof. Rewrap if necessary. See the following chart for storage times. When storing meat longer than the times given, freeze the meat. Fresh fish or shellfish use same day as purchased Chicken, ground beef, variety meats (liver)..... 1-2 days Cold cuts, steaks/roasts 3-5 days Cured meats 7-10 days Leftovers - Cover leftovers with plastic wrap, aluminum foil, or plastic containers with tight lids.

Crisper

Crisper Drawers

To remove and replace the crisper drawer:

1. Slide the crisper drawer straight out to the stop. Lift the front and slide the drawer out the rest of the way.
2. Replace the drawer by sliding the drawer in fully past the stop.

Crisper Cover

Style 1 - Plastic Cover

To remove and replace the crisper cover:

1. Remove the crisper(s).

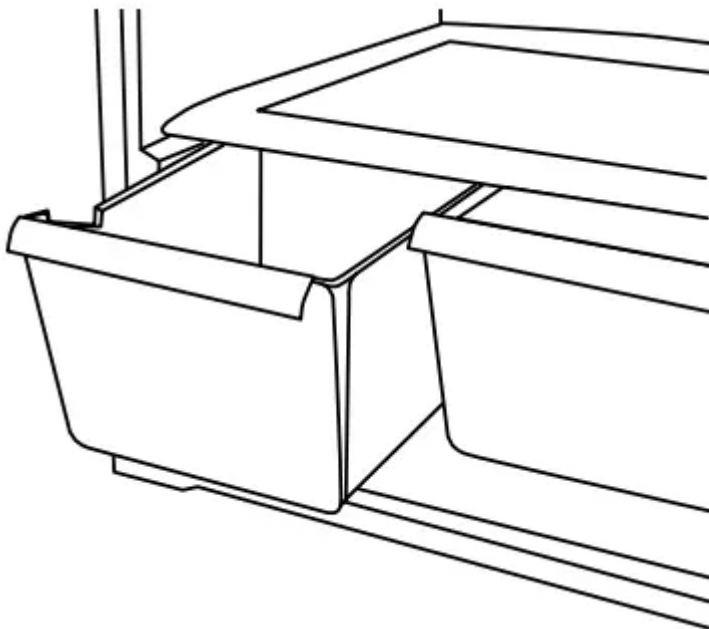

2. Lift the cover up and slide it out.
3. Replace the cover by fitting the cover tabs into lowest cabinet slots and pushing them in. Lower the front retainers into place.

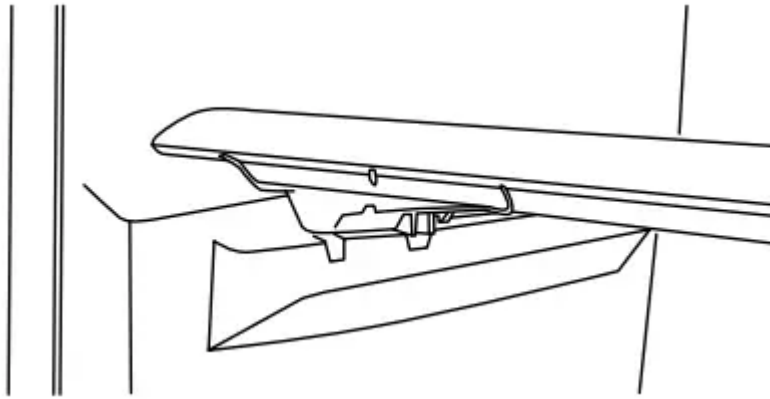

Style 2 - Glass Cover

To remove and replace the crisper cover:

1. Pull the glass straight out.
2. Replace the glass by pushing it straight in.

FREEZER FEATURES

Freezer Shelf (on some models)

To remove and replace the freezer shelf:

1. Remove items from the shelf.
2. Lift back of shelf over stop and slide shelf straight out.
3. Replace the shelf by sliding the back of the shelf into the tracks on walls of cabinet.
4. Be sure to slide the shelf in all the way.

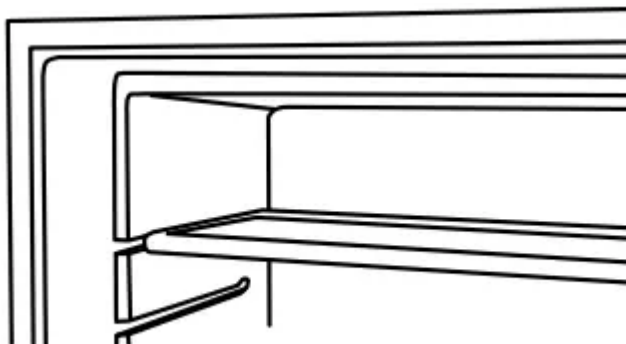

Frozen Food Storage Guide

Storage times will vary according to the quality and type of food, the type of packaging or wrap used (should be airtight and moisture-proof), and the storage temperature. Seal the package or container securely to avoid taste and odor

transfer throughout the product. Ice crystals inside a sealed package are normal. This simply means that moisture in the food and air inside the package have condensed, creating ice crystals. Put no more unfrozen food into the freezer than will freeze within 24 hours (no more than 2 to 3 lbs of food per cubic foot [907 to 1,350 g per L] of freezer space). Leave enough space in the freezer for air to circulate around packages. The freezer door must close tightly.

NOTE: For more information on preparing food for freezing, check a freezer guide or reliable cookbook.

DOOR FEATURES

Door Rails

Snap on Door Rails (on some models)

To remove and replace the rails:

1. Depending on your model, remove the rails by pushing in slightly on the front of the bracket while pulling out on the inside tab. Repeat these steps for the other end.
2. Replace the rails by aligning the ends of the brackets with the buttons on the sides of the door liner. Firmly snap bracket and assembly onto the tabs above the shelf as shown.



Drop-in Door Rails (on some models)

To remove and replace the rails:

1. Remove the rails by pulling straight up on each end of the rail.
2. Replace the rails by sliding the shelf rail into the slots on the door and pushing the rail straight down until it stops.

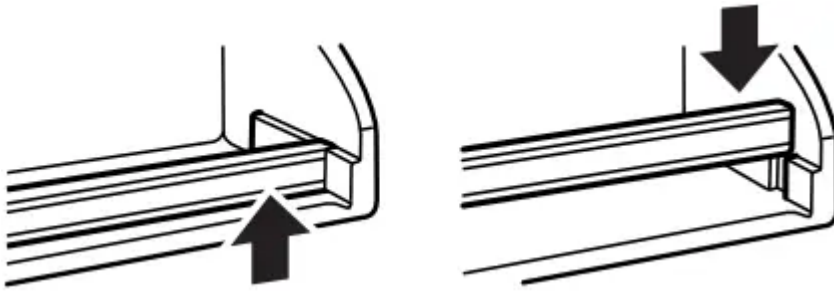

REFRIGERATOR CARE

Cleaning

Both the refrigerator and freezer sections defrost automatically. However, clean both compartments about once a month to avoid buildup of odors. Wipe up spills immediately.

IMPORTANT: Because air circulates between both sections, any odors formed in one section will transfer to the other. You must thoroughly clean both sections to eliminate odors. To avoid odor transfer and drying out of food, wrap or cover foods tightly.

To Clean Your Refrigerator:

NOTE: Do not use abrasive or harsh cleaners such as window sprays, scouring cleansers, flammable fluids, cleaning waxes, concentrated detergents, bleaches or cleansers containing petroleum products on plastic parts, interior and door liners or gaskets. Do not use paper towels, scouring pads, or other harsh cleaning tool.

1. Unplug refrigerator or disconnect power.
2. Hand wash, rinse, and dry removable parts and interior surfaces thoroughly. Use a clean sponge or soft cloth and a mild detergent in warm water.
3. Wash stainless steel and painted metal exteriors with a clean sponge or soft cloth and a mild detergent in warm water. Dry thoroughly with a soft cloth.

NOTE: To keep your stainless steel refrigerator looking like new and to remove minor scuffs or marks, it is suggested that you use the manufacturer's approved Stainless Steel Cleaner and Polish. To order the cleaner, see the "Accessories" section.

IMPORTANT: This cleaner is for stainless steel parts only! Do not allow the Stainless Steel Cleaner and Polish to come into contact with any plastic parts such as the trim pieces, dispenser covers or door gaskets. If unintentional contact does occur, clean plastic part with a sponge and mild detergent in warm water. Dry thoroughly with a soft cloth.

4. Clean the condenser coils regularly. Coils may need to be cleaned as often as every other month. This may help save energy.

- Pull refrigerator out away from the wall. See “Unpack the Refrigerator.”
 - Vacuum coils when they are dusty or dirty.
 - Roll refrigerator back into place. Make sure to leave 1" (2.5 cm) between the cabinet back and the wall.
 - Check to see that the refrigerator is level.
5. Plug in refrigerator or reconnect power.

Changing the Light Bulbs

Refrigerator Light

1. Unplug refrigerator or disconnect power.
2. Reach behind the control panel and unscrew the bulb.
3. Replace the bulb with a 40-watt, appliance bulb.
4. Plug in refrigerator or reconnect power.

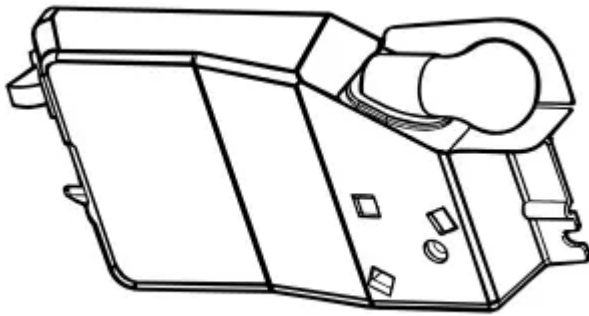

Vacation and Moving Care

Vacations

If You Choose to Leave the Refrigerator On While You're Away:

1. Use up any perishables and freeze other items.
2. If your refrigerator has an automatic ice maker, and is connected to the household water supply, turn off the water supply to the refrigerator. Property damage can occur if the water supply is not turned off.
3. If you have an automatic ice maker, turn off the ice maker. NOTE: Raise the wire shutoff arm to OFF (up) position.
4. Empty the ice bin.

If You Choose to Turn Off the Refrigerator Before You Leave:

1. Remove all food from the refrigerator.
2. If your refrigerator has an automatic ice maker:

- Turn off the water supply to the ice maker at least one day ahead of time.
 - When the last load of ice drops, raise the wire shutoff arm to the OFF (up) position.
3. Turn off the Temperature control(s). See “Using the Control(s).”
 4. Clean refrigerator, wipe it, and dry well.
 5. Tape rubber or wood blocks to the tops of both doors to prop them open far enough for air to get in. This stops odor and mold from building up.

Moving

When you are moving your refrigerator to a new home, follow these steps to prepare it for the move.

1. If your refrigerator has an automatic ice maker:
 - Turn off the water supply to the ice maker at least one day ahead of time.
 - Disconnect the water line from the back of the refrigerator.
 - When the last load of ice drops, raise the wire shutoff arm to the OFF (up) position.
2. Remove all food from the refrigerator and pack all frozen food in dry ice.
3. Empty the ice bin.
4. Turn off the Temperature control(s). See “Using the Control(s).”
5. Unplug refrigerator.
6. Clean, wipe, and dry thoroughly.
7. Take out all removable parts, wrap them well, and tape them together so they don't shift and rattle during the move.
8. Depending on the model, raise the front of the refrigerator so it rolls more easily OR raise the leveling screws so they don't scrape the floor. See “Adjust the Door(s)” or “Door Closing and Door Alignment.”
9. Tape the doors closed and tape the power cord to the back of the refrigerator.

When you get to your new home, put everything back and refer to the “Installation Instructions” section for preparation instructions. Also, if your refrigerator has an automatic ice maker, remember to reconnect the water supply to the refrigerator.

PROBLEM SOLVER



| If you experience | Possible Causes and/or Recommended Solutions |
|-----------------------------------|---|
| The refrigerator will not operate | <ul style="list-style-type: none"> ■ Not connected to an electrical supply - Plug the power cord into a grounded 3-prong outlet. Do not use an extension cord. ■ No power to the electrical outlet - Plug in a lamp to see if the outlet is working. ■ Household fuse blown or circuit breaker tripped - Replace the fuse or reset the circuit breaker. If the problem continues, contact an electrician. ■ Control is not turned on - Turn the refrigerator control on. ■ New Installation - Allow 24 hours following installation for the refrigerator to cool completely |
| The motor seems to run too much | <p>Your new refrigerator may run longer than your old one. Energy efficient refrigerators run longer at lower, more energy efficient speeds. Your refrigerator may run even longer if the room is warm, a large food load is added, the door is opened often, or if the door has been left open.</p> |
| The refrigerator is noisy | <p>Refrigerator noise has been reduced over the years. Due to this reduction in operating noise, you may notice unfamiliar noises that are normal. Following are some normal sounds with an explanation:</p> <ul style="list-style-type: none"> ■ Buzzing - heard when the water valve opens to fill the ice maker ■ Clicking/Snapping - valves opening or closing ■ Pulsating - fans/compressor adjusting to optimize performance ■ Rattling - flow of refrigerant, water line, or from items placed on top of the refrigerator ■ Sizzling/Gurgling - water dripping on the heater during defrost cycle ■ Popping - contraction/expansion of inside walls, especially during initial cool-down |



| | |
|--|--|
| | <ul style="list-style-type: none"> ■ Water running - may be heard when ice melts during the defrost cycle and water runs into the drain pan ■ Creaking/Cracking - occurs as ice is being ejected from the ice maker mold. |
| The door will not close completely | The door is blocked open - Move food packages away from door. Push bin or shelf back into the correct position. Make sure the crisper cover is fully pushed in, so that the back rests on the supports. |
| The door is difficult to open | Gaskets are dirty or sticky - Clean gaskets and contact surfaces with mild soap and warm water. Rinse and dry with soft cloth. |
| Temperature is too warm | <ul style="list-style-type: none"> ■ New Installation - Allow 24 hours following installation for the refrigerator to cool completely. ■ Door(s) opened often or not closed completely - Allows warm air to enter refrigerator. Minimize door openings and keep doors fully closed. ■ A large amount of warm food has been recently added - Allow several hours for refrigerator to return to normal temperature. ■ Check that the Temperature Control(s) are set correctly for the surrounding conditions - Adjust the controls to one setting colder. Check temperature in 24 hours. See "Using the Control(s)." |
| There is interior moisture buildup NOTE: Some moisture buildup is normal | <ul style="list-style-type: none"> ■ Humid room - Contributes to moisture buildup in the refrigerator. ■ Door(s) opened often or not closed completely - Allows humid air to enter the refrigerator. Minimize door openings and keep door fully closed. |
| The ice maker is not producing ice or not enough ice (on some models) | <ul style="list-style-type: none"> ■ The ice maker is not connected to a water supply - Connect refrigerator to water supply and turn water shutoff valve fully open. ■ A kink in the line can reduce water flow - Straighten the water source line. |



| | |
|--|---|
| | <ul style="list-style-type: none"> ■ Ice maker is not turned on - Make sure the ice maker wire shutoff arm or switch (depending on model) is in the ON position. ■ New installation - Wait 24 hours after ice maker installation for ice production to begin. Wait 3 days for full ice production. ■ Large amount of ice recently removed - Allow sufficient time for ice maker to produce more ice. ■ Ice cube jammed in the ice maker ejector arm - Remove ice from the ejector arm with a plastic utensil. ■ A reverse osmosis water filtration system connected to your cold water supply can decrease water pressure - See "Water Supply Requirements." |
| <p>The ice cubes are hollow or small (on some models) NOTE: This is an indication of low water pressure.</p> | <ul style="list-style-type: none"> ■ The water valve is not completely open - Turn the water shutoff valve fully open. ■ A kink in the line can reduce water flow - Straighten the water source line. ■ A reverse osmosis water filtration system connected to your cold water supply can decrease water pressure - See "Water Supply Requirements." ■ If questions regarding water pressure remain, call a licensed, qualified plumber. |
| <p>Off-taste, odor or gray color in the ice (on some models)</p> | <ul style="list-style-type: none"> ■ New plumbing connections can cause discolored or off-flavored ice - Discard the ice and wash the ice storage bin. Allow 24 hours for the ice maker to make new ice, and discard the first 3 batches of ice produced. ■ Ice stored too long can develop an off-taste - Discard ice. Wash ice bin. Allow 24 hours for ice maker to make new ice. ■ Food odor transferring to ice - Use airtight, moisture proof packaging to store food. ■ There are minerals (such as sulfur) in the water - A water filter may need to be installed to remove the minerals. |



Warning

This content is compiled from multiple sources and is provided for reference purposes only. It may not be complete or fully applicable to all situations. If you are unable to resolve your issue, please contact the product manufacturer or an authorized service provider for official support.

Document generated by [ManualsFile](#)