

Overview

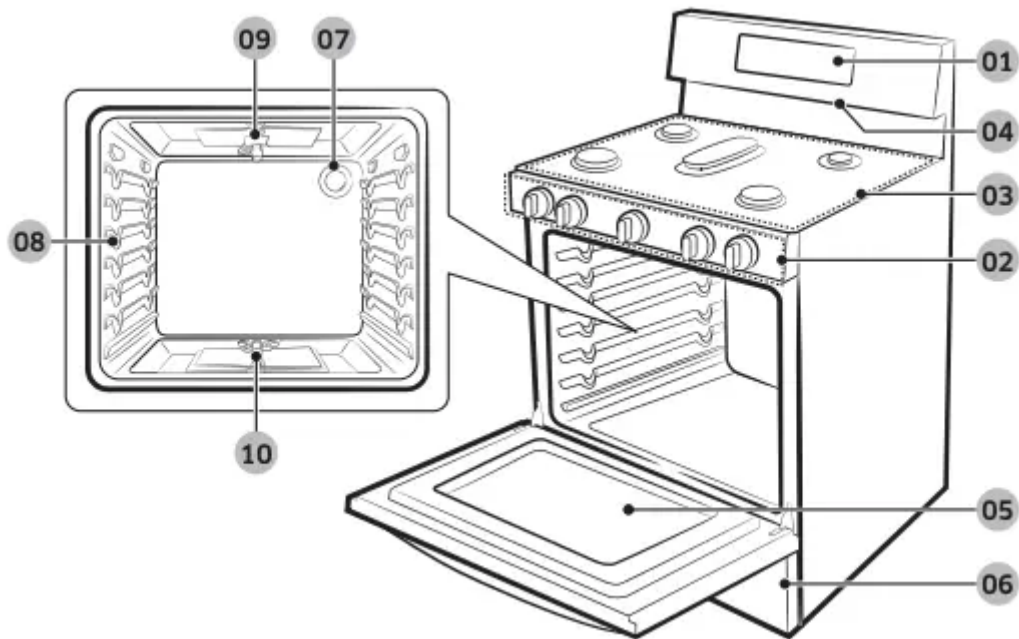

01 Display

02 Surface burner knobs (5 pcs)

03 Surface burners

04 Oven Vent

05 Removable oven door

06 Storage drawer

*07 Oven light **

08 Oven rack system

09 Broil oven burner

10 Bake oven burner

NOTE If you need a part marked with a "*", you can buy it from the Samsung Contact Center (1-800-726-7864).

What's included

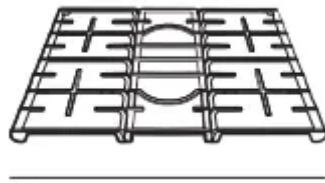

Surface burner grates (3) *

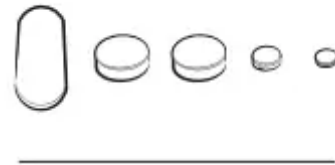

Surface burners and caps (5) *



Flat rack (2) *

NOTE If you need an accessory marked with an * (asterisk), please contact the Samsung Call Center at 1-800-726-7864 or visit our on-line parts web site at samsungparts.com.

Control panel

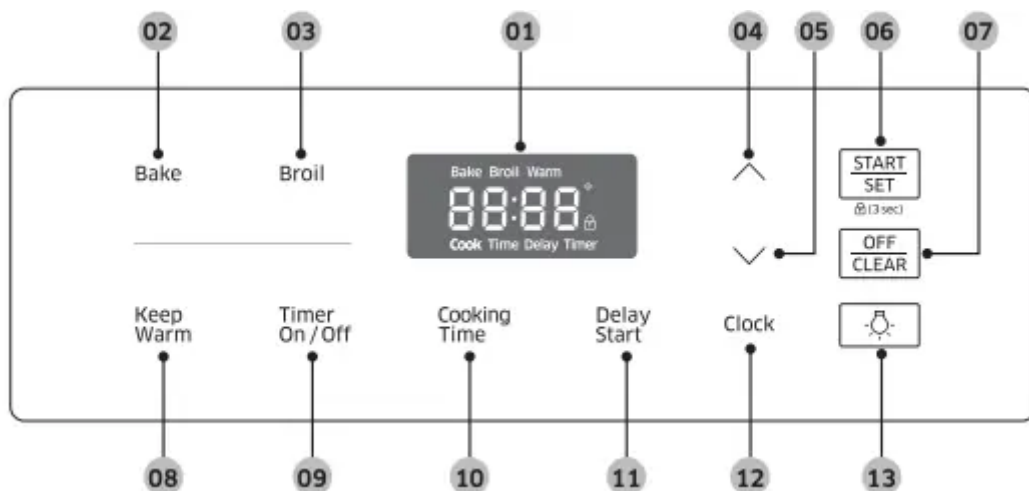

01 Display: Shows the time of day, oven temperature, whether the oven is in the bake or broil mode, and displays the time set for the timer or for automatic oven operations.

02 Bake: Bake food using the oven burner.

03 Broil: Broil food using the upper oven burner only.

04 ^ (Up): Set the cooking temperature and time.

05 v (Down): Set the cooking temperature and time.

06 START/SET (Lock): Start a function or set the time. Lock the control panel to prevent accidents.

07 OFF/CLEAR: Cancel the current operation but not the timer.

08 Keep Warm: Keep cooked food warm at lower temperatures.

09 Timer On/Off: Activate or deactivate the timer.

10 Cooking Time: Set the cooking time.

11 Delay Start: Set the oven to start at a certain time.

12 Clock: Set the clock time.

13 Oven Light: Turn on/Turn off the oven light.

NOTES

- The Door Lock function is not available on this model. Only the Control Lock function is provided.
- To change the cooking temperature rapidly 10 degrees at a time, press and hold the up or down arrow button.

Clock

You must set the clock correctly to ensure the automatic features work properly. Only a 12-hour clock is available on this model.

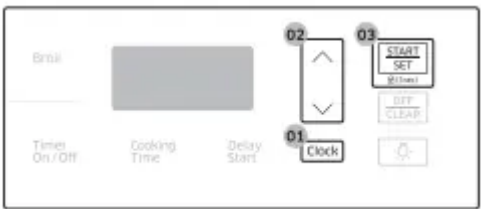
	<p>To set the clock time</p> <ol style="list-style-type: none">1. Press the CLOCK button.2. Enter the current time using the arrow buttons.3. Press the START/SET button to confirm the settings.
---	--

NOTE You can set/change the clock or the kitchen timer before you start a cooking mode or while most cooking modes are operating. However, you cannot set or change the time if a time based function is operating (Time Bake, for example) or the Sabbath option is enabled.

Kitchen timer

The kitchen timer gives you an extra timer you can use to time cooking tasks such a boiling eggs. It does not, however, start or stop any cooking operation. You can set the timer from 1 minute to 9 hours and 59 minutes.

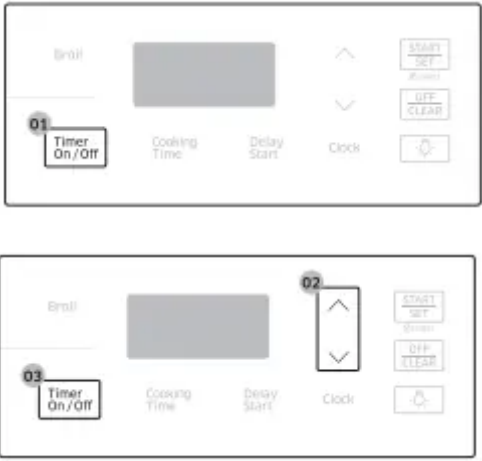

1. Press the Timer On/Off button.

Once	Twice
Hours/ Minutes	Turn off or Cancel the timer

2. Press the arrow buttons to enter the amount of time you want in minutes or hours and minutes.

3. Press the Timer On/Off button to start the timer.

Gas range

General cooktop instructions



STEP 1

Put all ingredients into a cooking container (pan, pot, etc).

STEP 2

Place the container on a surface burner.

STEP 3

Ignite the surface burner.

Oven vent/cooling vent

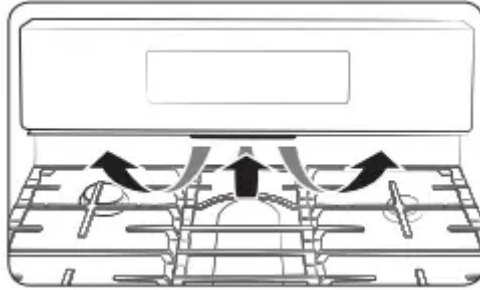

The oven vent is located under the oven Control panel. Proper air circulation prevents oven burner combustion problems and ensures good performance.

- Do not block the vent or the area around the vent.
- Use caution when placing items near the vent. Hot steam can cause them to overheat or melt.

Cookware

Requirements

- Flat bottom and straight sides.
- Tight-fitting lid.
- Well-balanced with the handle weighing less than the main portion of the pot or pan.

Material characteristics

- Aluminum: An excellent heat conductor. Some types of food may cause the aluminum to darken. However, anodized aluminum cookware resists staining and pitting.
- Copper: An excellent heat conductor but discolors easily.
- Stainless steel: A slow heat conductor with uneven cooking performance but is durable, easy to clean, and resists staining.
- Cast-Iron: A poor conductor but retains heat very well.
- Enamelware: Heating characteristics depend on the base material.
- Glass: A slow heat conductor. Use only glass cookware that is specified for range top cooking or oven use.

Size limitations

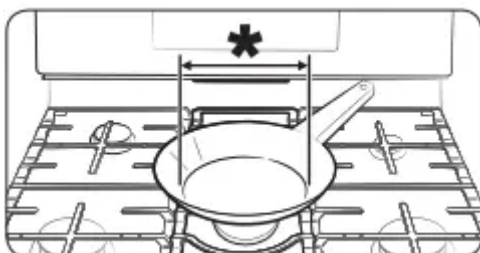

CAUTION

- Do not place a small pan or pot with a bottom diameter of about 6 inches or less on the center grate. This cookware may tip over. Use the rear burners for this small sized cookware.

* : 6 inches or less

- Always make sure cookware handles are turned to the side or rear of the cooktop and not over other surface burners. This will minimize the chance of burns, spillovers, and the ignition of flammable materials that can be caused if pots or pans are bumped accidentally.
- When using glass cookware, make sure it is designed for top-of-range cooking.
- Never leave plastic items on the cooktop. Hot air from the vent can melt or ignite plastic items or cause a building up of dangerous pressure in closed plastic containers.
- Make sure you hold the handle of a wok or a small one-handed pot while cooking.

Gas burners

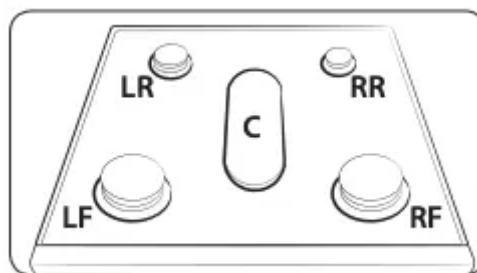

Each burner has a corresponding knob that lets you to set the flame level from LO to HI. In addition, each burner knob has a LITE setting. Turning a knob to LITE ignites the corresponding burner. The burner indicators are located above each knob, showing which burner the knob controls. Each burner is designed for specific cooking purposes. See the table below.

Position	Purpose	Food type	Characteristics
Right Front (RF) 17,000 BTU	Power heating	Boiling food	Maximum output
Right Rear (RR) 5,000 BTU	Low simmering	Chocolate, casseroles, sauces	Delicate food that requires low heat for a long time
Center (C) 9,500 BTU	Grilling/Griddling	Pancakes, hamburgers, fried eggs, hot sandwiches	General-purpose cooking
Left Front (LF) 15,000 BTU	Quick heating	General	General-purpose cooking
Left Rear (LR) 9,500 BTU	General heating/ Low simmering	General food, casseroles, tomato sauce*	General-purpose cooking

* Tomato sauce needs to be stirred while it is simmering.

Ignition

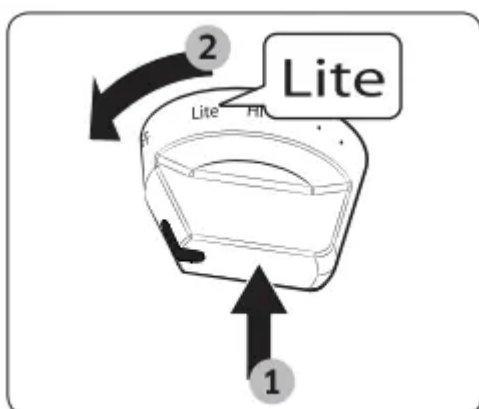

Make sure all surface burners are properly installed. To light a burner:

1. Push in the control knob, and then turn it to the LITE position. You will hear a "clicking" sound indicating the electronic ignition system is working properly.
2. After the surface burner lights, turn the control knob to shift it out of the LITE position and turn off the electronic ignition system.
3. Turn the control knob to adjust the flame level.

Manual ignition

If there is a power failure, you can ignite the burner manually. Use caution when doing this.

1. Hold a long gas grill lighter to the surface burner you want to light.
2. Push in the control knob for that burner, and then turn it to the LITE position. Turn on the grill lighter to ignite the burner.
3. After the burner is lit, turn the control knob to adjust the flame level.

Flame level

The flames on the burners should always stay under the cookware, and should not extend beyond the cookware bottom at any time.



WARNING

- Flames larger than the cookware bottom may result in a fire or physical injury.
- When you set a burner to simmer, do not turn the burner knob quickly. Watch the flame to make sure it stays on.
- After turning on a surface burner, check to make sure that the burner has ignited. Adjust the level of the flame by turning the burner knob.
- Always turn off the surface burner controls before removing cookware. All surface burner controls should be turned OFF when you are not cooking.
- Always turn the burners off before you go to sleep or go out.
- If you smell gas, turn off the gas to the range and call a qualified service technician. NEVER use an open flame to locate a leak.

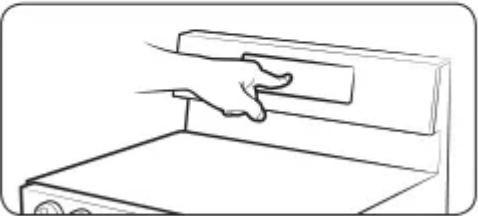
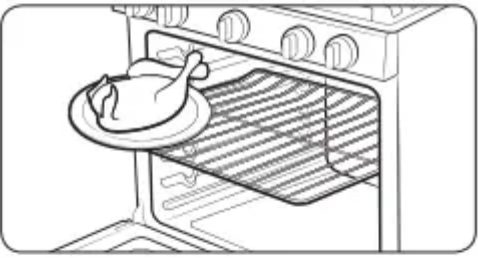

Gas oven

General oven instructions

	<p>STEP 1 Put all ingredients in a heat-safe container.</p>
	<p>STEP 2 Select a cooking mode, and then start preheating.</p>
	<p>STEP 3 Place the container on a rack.</p>
	<p>STEP 4 Close the door and start cooking.</p>

Cooking mode

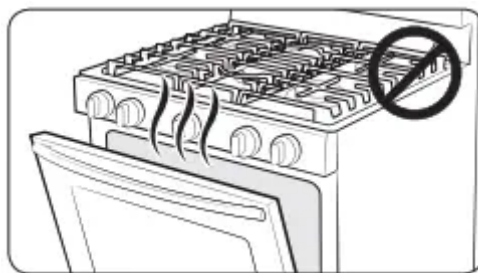

- Make sure to close the door before you start cooking.

- If you leave the door open for 20-30 seconds while the oven is in the baking or broiling modes, the oven burner shuts off. To restart the burner, close the door.

Baking

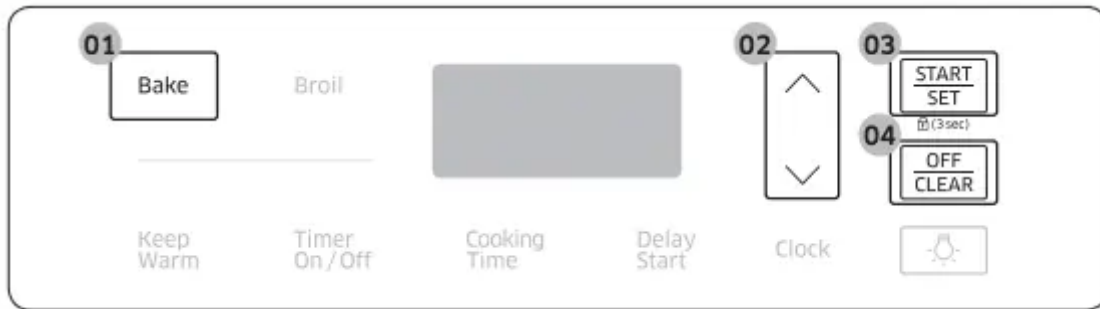

1. Press the Bake button.
2. If necessary, use the arrow buttons to change the default temperature (350 °F). You can set the oven to any temperature from 175 °F to 550 °F.
3. Press the START/SET button.
 - The oven preheats until it reaches the temperature you set.
 - When preheating is complete, place the food in the oven, and then close the door.
4. When cooking is complete, press the OFF/CLEAR button, and then take out the food.

NOTES

- To change the temperature during cooking, repeat steps 1 through 3 above.
- When pre-heating is complete, the oven beeps 6 times.
- To change the cooking temperature rapidly 10 degrees at a time, press and hold the up or down arrow button.

Broiling

Broiling uses the oven broil burner at the top of the oven to cook and brown food. Meat or fish must be put on a broiling grid in a broiling pan. Preheating for 5 minutes before broiling is recommended.

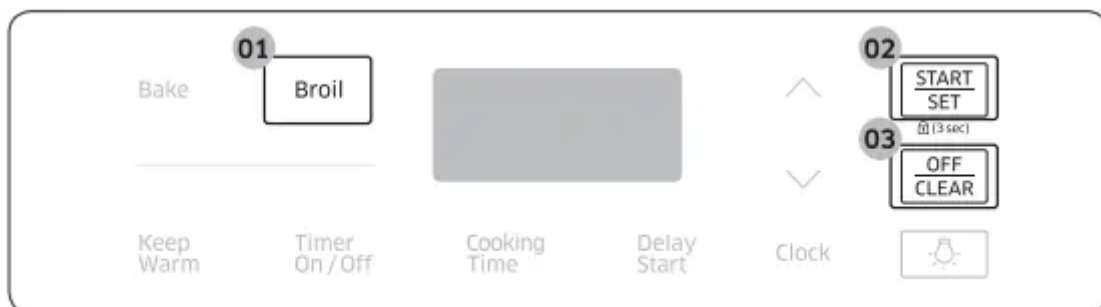

1. Put food on a broiling grid in a broiling pan.

2. Press the Broil button once for HI temperature broiling or twice for LO.
3. Press the START/SET button to start the broiler.
4. Let the oven pre-heat for 5 minutes.
5. Place the pan on the desired rack, and then close the oven door.
6. When one side of the food is browned, turn it over, close the oven door, and start cooking the other side.
7. When cooking is complete, press the OFF/CLEAR button.

NOTE For a detailed broil rack guide, see page 16.

Temperature Limitations by Mode

Feature	Min	Max
Bake	175 °F (80 °C)	550 °F (285 °C)
Broil	LO	HI
Keep Warm	-	3 hours

Using the oven racks

Your gas oven range comes with 3 racks and 7 rack positions. The rack positions are delineated by rack guides which support the racks. Each rack guide has a stop that prevents racks from loosening during the oven's operation. Each rack has stoppers that need to be placed correctly on the rack guides. The stoppers prevent the racks from accidentally coming out of the oven completely when you pull the racks out.

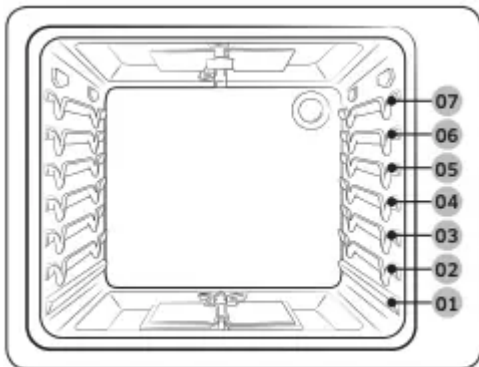

Type of food	Rack position
Broiling hamburgers	6
Broiling meats or small cuts of poultry, fish	6-4
Bundt cakes, pound cakes, frozen pies, casseroles	4 or 3
Fresh pizza, angel food cakes, small roasts	2
Turkey, large roasts, hams	1

CAUTION

- Do not cover an oven rack with aluminum foil. This will hamper heat circulation, resulting in poor baking.
- Do not place aluminum foil on the oven bottom. The aluminum can melt and damage the oven.
- Arrange the oven racks only when the oven is cool.
- When placing an oven rack in the topmost rack position (position 7), make sure the rack is situated stably on the embossed stop.

NOTE

This table is for reference only

Inserting and removing an oven rack

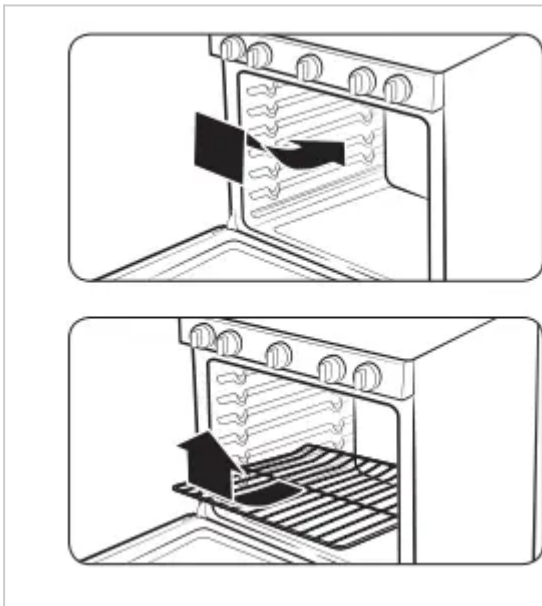

To insert an oven rack

1. Place the rear end of the rack on a rack guide.
2. Slide the rack into the rack guide while holding the front end of the rack.

To remove an oven rack

1. Pull out the rack until it stops.
2. Pull up the front end of the rack and remove it from the rack guide.

Rack and Pan Placement

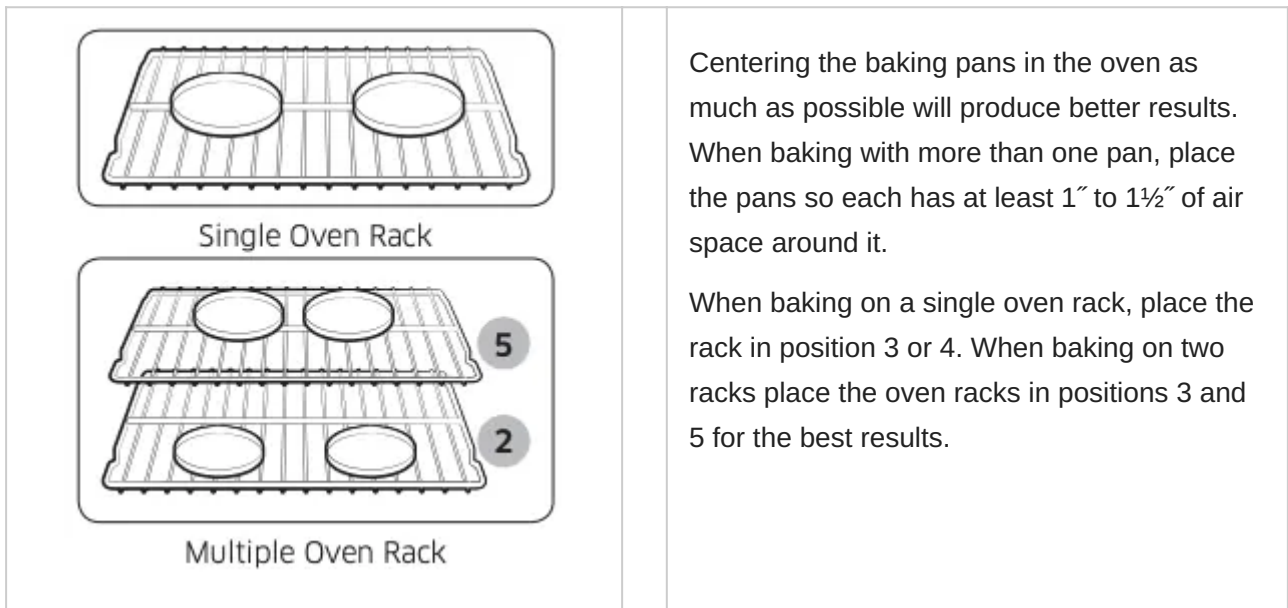

Cooking options

CAUTION Food that can easily spoil, such as milk, eggs, fish, poultry, and meat, should be chilled in a refrigerator before they are placed in the oven. Even when chilled, they should not stand for more than 1 hour before cooking begins and should be removed promptly when cooking is completed.

Timed Cook

Timed cooking sets the oven to cook foods at a set temperature for a set length of time. The oven automatically turns off when it finishes.

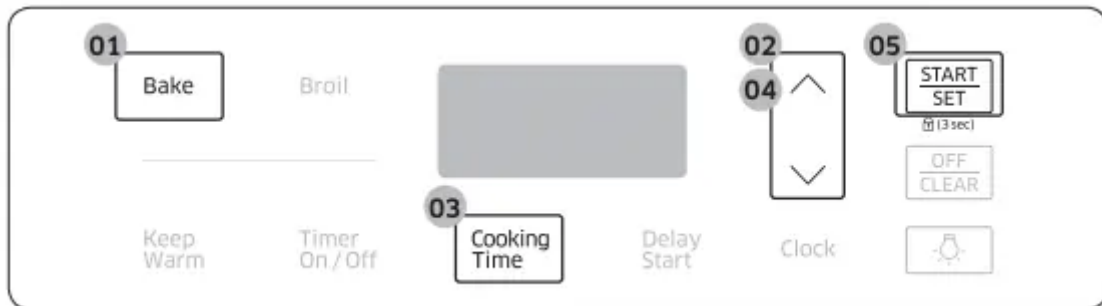

1. Press the Bake button.
2. If necessary, change the temperature using the arrow buttons.
3. Press the Cooking Time button.
4. Set the cooking time between 1 minute and 9 hours and 59 minutes (9:59) using the arrow buttons.
5. Press the START/SET button. The oven will automatically light and start preheating. The temperature will increase until it reaches the temperature you set.
6. When preheating is complete, put the container with the food on a rack, and then close the door. The oven starts cooking for the amount of time you set.

7. When the cooking time has elapsed, the oven will automatically shut off and then beep.

NOTE To change the programmed cooking time, press the Cooking Time button, and then enter a different time. Then, press the START/SET button.

Delay Start

The Delay Start function lets you use the kitchen timer to automatically start and stop another cooking program. Delay Start can be set before other cooking operations for up to 12 hours.

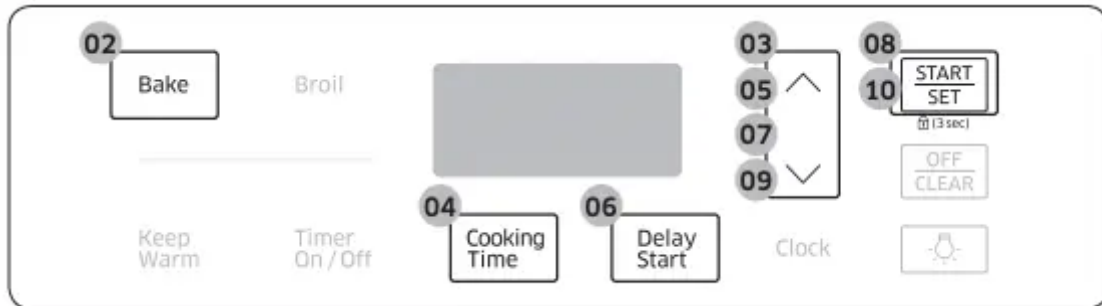

1. Place the container with the food on a rack, and then close the door.
2. Press the Bake button.
3. If necessary, change the temperature using the arrow buttons.
4. Press the Cooking Time button.
5. Set the cooking time between 1 minute and 9 hours and 59 minutes (9:59) using the arrow buttons
6. Press the Delay Start button.
7. Set the starting hour using the arrow buttons.
8. Press the START/SET button.
9. Set the starting minutes using the arrow buttons.
10. Press the START/SET button.
11. The oven starts cooking at the set time, and turns off automatically when it completes cooking.

NOTES

- To change the starting time, press the Delay Start button, enter a new starting time, and then press the START/SET button.
- To change the programmed cooking time, press the Cooking Time button, enter a different time, and then press the START/SET button.

Keep Warm

Keep cooked food warm at a low temperature up to 3 hours.

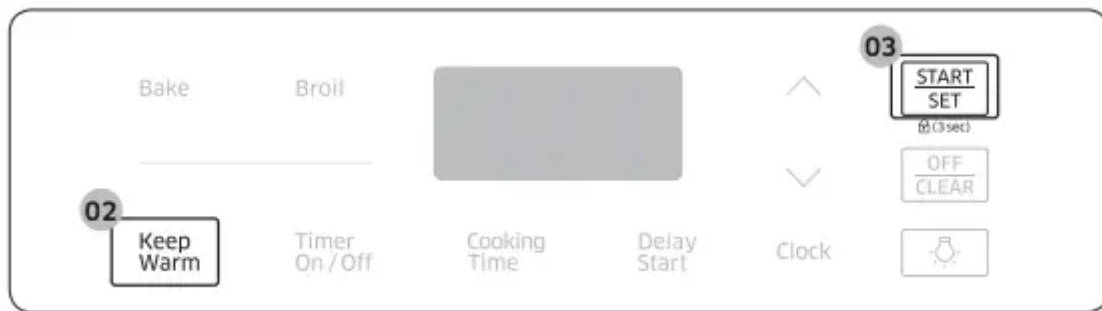

1. Place the container with the food on a rack, and then close the door.
2. Press the Keep Warm button.
3. Press the START/SET button. The oven heats up to 170 °F (77 °C).

NOTES

- You can cancel warming at any time by pressing the OFF/CLEAR button.
- To set the warming function during a timed cooking, press the Keep Warm button in timed cooking mode. When the timed cooking is complete, the oven will lower the temperature to the warming default, and keep that temperature until the warming mode ends or is canceled.

Oven Light

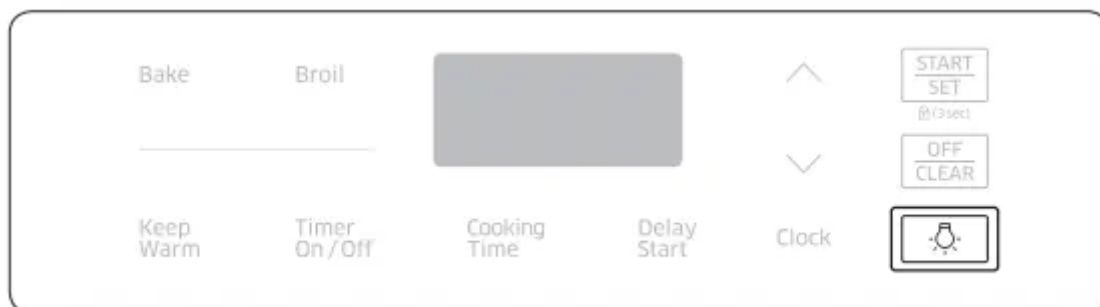

Press the Oven Light button to turn the oven light on and off.

The Sabbath Option

- The oven temperature can be set higher or lower after you have set this option.
- The display doesn't change and no beep sounds when you change the temperature.
- Once the oven is properly set for baking with the Sabbath option active, the oven will remain continuously on until the Sabbath feature is cancelled. This will override the factory preset 12 hour energy saving feature.
- If the oven light is needed during the Sabbath, press OVEN LIGHT before activating the Sabbath feature. Once the oven light is turned on and the Sabbath option is active, the oven light will remain on until the Sabbath option is turned off.
- If you want the oven light off, be sure to turn it off before activating the Sabbath feature.
- Do not use the surface cooktop when the Sabbath option is on.

To enable the Sabbath option

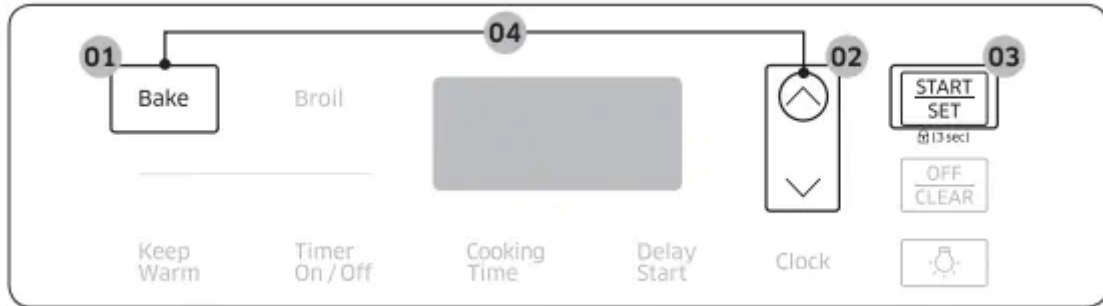

1. Press the Bake button.
2. Enter a desired temperature using the arrow buttons. The default temperature is 350 °F.
3. Press the START/SET pad. The display temperature changes after the oven temperature reaches 175 °F.
4. Press the Bake and ^ (Up) buttons simultaneously for 3 seconds to display "SAb". Once "SAb" appears, the oven control no longer beeps or displays any further changes

NOTES

- You can change the oven temperature once baking starts, but the display will not change or beep. After changing the temperature, it takes 15 seconds before the oven recognizes the change.
- You can turn off the oven at any time by pressing OFF/CLEAR. However, this doesn't deactivate the Sabbath option.
- To deactivate the Sabbath option, hold down Bake and ^ (Up) simultaneously for 3 seconds.
- You can set the cooking time before activating the Sabbath option.
- After a power failure, the oven will not resume operation automatically. "SAb" will appear in the control panel, but the oven will not go back on. Food can be safely removed from the oven, but you should not turn off the Sabbath option and turn the oven back on until after the Sabbath/Holidays.
- After the Sabbath observance, turn off the Sabbath option by pressing and holding Bake and (Up) simultaneously for at least 3 seconds.

CAUTION

- Do not attempt to activate any other functions except for Bake when the Sabbath option is on. Only the following buttons will function properly: the Arrow buttons, Bake, Oven START/SET, and Oven OFF/CLEAR.
- Do not open the oven door or change the oven temperature for about minutes after you have started the Sabbath option. Let the oven reach the set temperature. The oven fan operates only when the oven temperature increases.

Non-Cooking functions

Temperature adjust

The oven temperature has been calibrated at the factory. When first using the oven, follow the recommended recipe times and temperatures. If it appears that the oven is too hot or too cool, you can recalibrate the oven temperature. Before recalibrating, test a recipe by using a temperature setting that is higher or lower than recommended. The baking results should help you decide how much of an adjustment is needed. The oven temperature can be adjusted by $\pm 35^{\circ}\text{F}$ ($\pm 19^{\circ}\text{C}$).

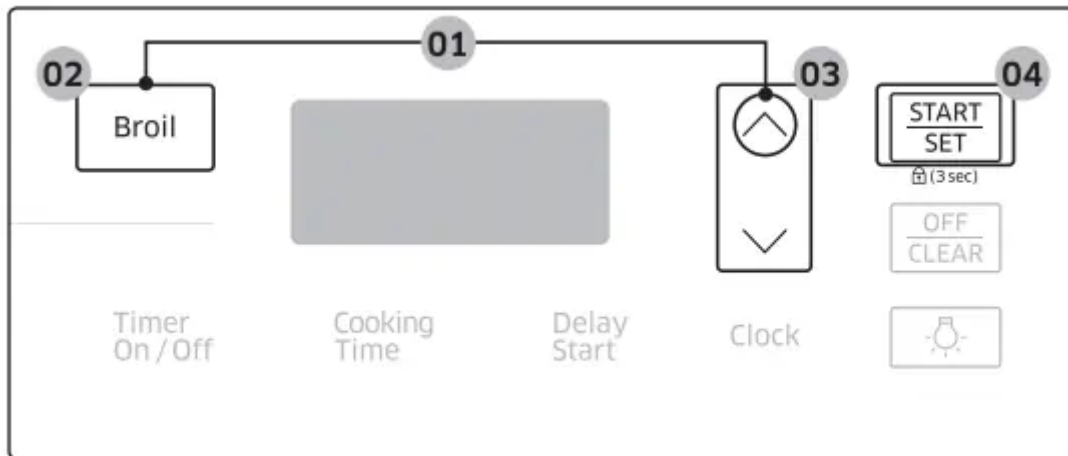

1. Press the Broil button and (Up) button simultaneously for 3 seconds.
2. Press the Broil button to select a higher(+) or lower(-) temperature.
3. Enter an adjusting temperature value using the arrow buttons.
4. Press the START/SET button to save the changes.

NOTE

This adjustment does not affect the broiling temperature, and is retained in memory after a power failure.

Sound

Mute/unmute the oven.

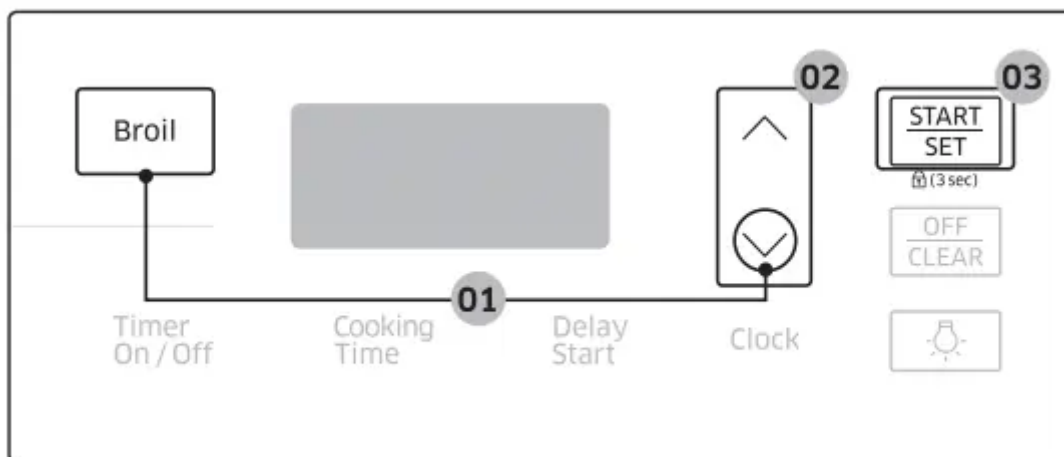

1. Press the Broil button and (Down) button simultaneously for 3 seconds.
2. Press the arrow buttons to select unmute or mute.
3. Press the START/SET button to save the changes.

Maintenance

Cleaning

Control panel

First, lock the control panel to prevent accidental operations and/or product tipping.

1. Press and hold the START/SET button for 3 seconds to lock the control panel.
2. Clean the control panel using a soft cloth dampened with plain water, warm soapy water, or glass cleaner. Do not spray cleansers directly onto the control panel.
3. When done, press and hold the START/SET button again for 3 seconds.

WARNING

- Make sure the control panel turns off and all surfaces of the gas oven are cool before cleaning. Otherwise, you can get burned.
- If the gas oven has been moved away from the wall, make sure the anti-tip device is reinstalled properly when the gas oven has been put into place again. Otherwise, the gas oven may tip over, causing physical injuries.
- Do not use steel-wool or abrasive cleansers of any kind. These can scratch or damage the surface.

Stainless steel surface

1. Remove any spills, spots, and grease stains using a soft, wet cloth.
2. Apply an approved stainless steel cleanser to a cloth or paper towel.
3. Clean one small area at a time, rubbing with the grain of the stainless steel if applicable.

4. When done, dry the surface using a soft, dry cloth.
5. Repeat steps 2 through 4 as many times as necessary.

CAUTION

- Do not use a steel-wool pad or abrasive cleanser on stainless steel surfaces. It will scratch the surface.
- Do not spray any type of cleanser into the manifold holes. The ignition system is located in those holes and must be kept free of moisture.

Racks

To keep the racks clean, remove them from the cavity, and soak them in lukewarm soapy water. Then, scour impurities off the racks using a plastic scouring pad. If the racks do not slide in and out smoothly after you have cleaned them, rub the side rail guides with wax paper or a cloth containing a few drops of cooking oil. This will help the racks glide more easily on their tracks.

NOTES

- Do not use a dishwasher to clean the racks.
- If a rack does not slide in and out smoothly, apply a few drops of cooking oil to the oven rack guides.
- If a rack becomes too difficult to slide in or out, lubricate the rack.
- To purchase the graphite lubricant, contact us at 1-800-SAMSUNG (726-7864).
- For online shopping, visit samsungparts and search for part DG81-01629A.

Door

Do not remove the inner gasket of the oven door for cleaning.

Inner side

- Inner surface: Clean the inner side of the door manually using a soapy plastic scouring pad, and then wipe with a dry cloth. Take care not to get the gasket wet or allow moisture into the door.

Outer side

- Outer surface: Follow the cleaning instructions for the stainless steel surface in the previous section.
- Outer glass: Clean the outer glass using a glass cleanser or soapy water. Rinse and dry thoroughly. Take care not to get the gasket wet or allow moisture into the door.

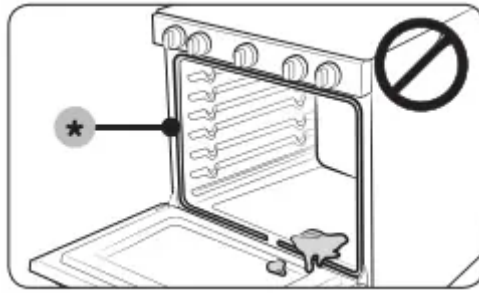

CAUTION

- Do not let moisture enter the door or contact the door gasket (*). Moisture may reduce the gasket's performance.
- Do not let moisture or water enter the burner, electrical controls, or switches.

Surface burners

Burner controls

Make sure all surface burner knobs are in the OFF position.

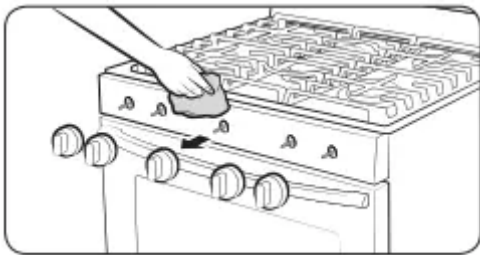

1. Pull the knobs off the control valve stems as shown.
2. Clean the knobs in warm, soapy water. Then, rinse and dry them thoroughly.
3. Clean the stainless steel surfaces using stainless steel cleaner.
4. Push the knobs back onto the control valve stems.

CAUTION

- Do not clean the control knobs in a dish washer.
- Do not spray cleansers directly onto the control panel. Moisture entering the electric circuits may cause electric shock or product damage.

Cooktop surface

The porcelain-enameled cooktop surface needs to be kept clean. We recommend that you remove food spills immediately after they take place.

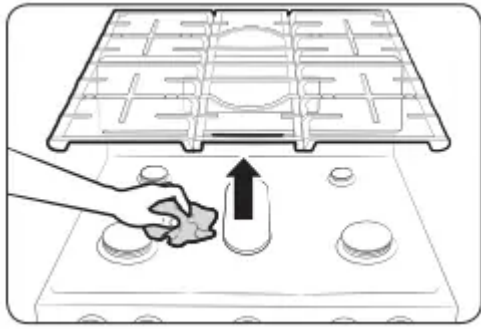

1. Turn off all surface burners.
2. Wait until all burner grates cool down, and then remove them.
3. Clean the cooktop surface using a soft cloth. If food spills run into gaps of the burner components, remove the burner cap and the head, and then wipe up the spills.
4. When you are done cleaning, reinsert the burner components, and then put the burner grates back into position.

CAUTION

- Do not use a steel-wool pad or abrasive cleaner, which can scratch or damage the enamel surface.
- Do not remove the cooktop surface to clean it. The gas lines leading to the burner manifolds can be damaged, resulting in a fire or system failure.

Burner grates and components

Turn off all surface burners and make sure they have all cooled down

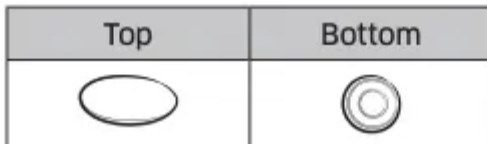
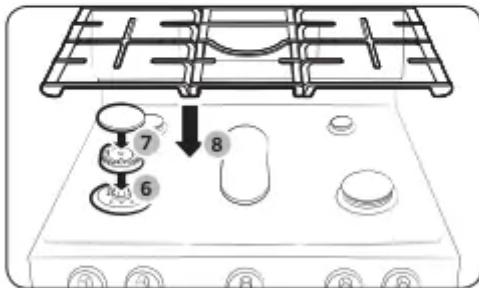
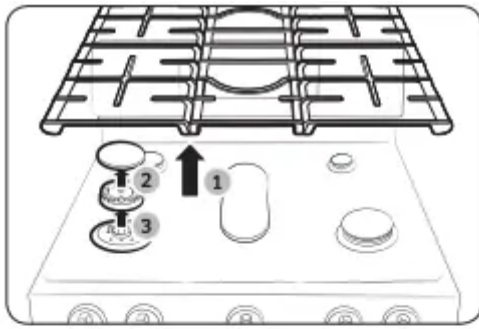

1. Remove the burner grates.
2. Remove the burner caps from the burner heads.
3. Remove the burner heads from the valve manifolds to reveal the starter electrodes.
4. Clean all removable grates and burner components in warm, soapy water. Do not use steel-wool pads or abrasive cleaners.
5. Rinse and dry the grates and burner components thoroughly
6. Return the burner heads to their positions on top of the manifold valves. Make sure a starter electrode is inserted through the hole in each burner head.
7. Return the burner caps to their positions on top of burner heads. To ensure proper and safe operation, make sure the burner caps lie flat on top of the burner heads.
8. Reinstall the burner grates in their respective positions.
9. Turn on each burner and check if it operates properly. After verifying that a burner operates normally, turn it off.

CAUTION

- The starter electrodes are not removable. Do not attempt to remove them by force.
- Make sure all burner components (heads and caps) are reinstalled properly. They are stable and rest flat when installed properly.
- To avoid chipping, do not bang grates and caps against each other or against hard surfaces such as cast iron cookware.

Replacement

Oven light

The oven light is a standard 40-watt appliance bulb. It comes on when you open the oven door.

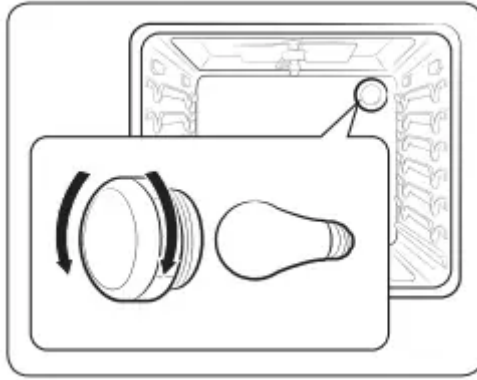

1. Turn off the oven.
2. Make sure the oven and oven light are cool.
3. Open the door, and remove the glass cover by turning it counterclockwise.
4. Remove the oven light from the socket by turning it counterclockwise.
5. Insert a new 40-watt appliance bulb into the socket, and then turn it clockwise to tighten.
6. Reinsert the glass cover, and then turn it clockwise to tighten.

CAUTION

To prevent electric shock, make sure the gas oven is turned off and cool before replacing the oven light.

NOTE

Remove the racks if they prevent you from accessing the oven light.

Reinstallation

Oven door

To remove the oven door

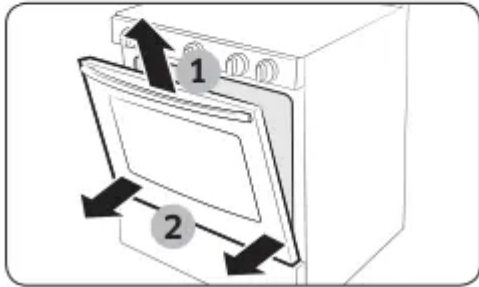
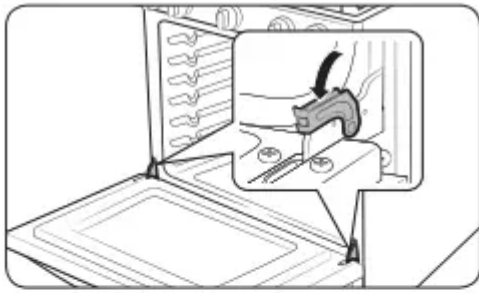

1. Turn off the oven.
2. Fully open the oven door.
3. Pull the hinge locks away from the oven body and down toward the door frame into the unlocked position.
4. Close the door to 5 degrees from vertical. This is the removal position.
5. While holding both sides of the oven door tightly, lift it up and out until the hinge arms come clear of the slots at the bottom of the oven door.
6. Place the door in a safe location.

WARNING

- The door is very heavy. Be careful when removing and lifting the door. Do not lift the door by the handle.
- Take care when moving the oven door. Improper handling could result in physical injury.
- To prevent electric shock, make sure the oven is turned off before removing the oven door.

To re-install the oven door



1. Firmly grasp both sides of the door at the top.
2. With the door set at the same angle as the removal position (about 5 degrees from vertical), slide the hinge arms into the hinge slots at the bottom of the door.
3. Open the door fully. If you cannot open the door fully, the hinge arms are not properly in the hinge slots.
4. Lock the hinge arms by pushing them up against the front frame of the oven.
5. Close the door, and make sure it opens and closes normally.

Storage drawer

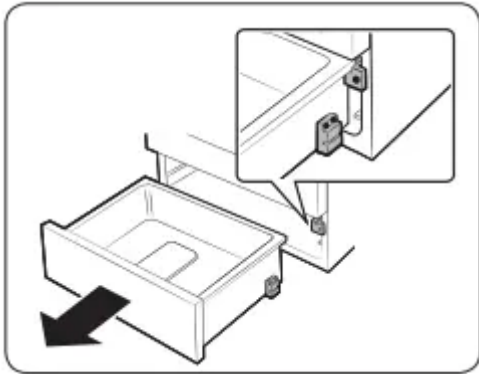

1. Pull out the drawer and remove any stored content.
2. While supporting the drawer, pull it out until the top of the drawer sides come out of the two nylon drawer guides. Then, lift to remove the drawer.
3. Clean the drawer with warm, soapy water. Rinse and dry thoroughly.
4. Place the top of both drawer sides in the openings on the two nylon drawer guides and push in enough to support the drawer.
5. Replace any stored content, and then push in the drawer while slightly lifting the front to close it.

Troubleshooting

If you encounter a problem with the range, check the tables starting below, and then try the suggested actions.

Checkpoints

Gas safety

Problem	Possible cause	Action
You smell gas.	The surface burner knob is not in the OFF position and the burner is not lit.	Turn the burner knob to OFF
	There is a gas leak.	Clear the room, building, or area of all occupants. Immediately call your gas supplier from a neighbor's phone. Do not call from your phone. It is electrical and could cause a spark that could ignite the gas. Follow the gas supplier's instructions. If you cannot reach your gas supplier, call the fire department.

Surface burner





Problem	Possible cause	Action
All burners do not light.	The power cord is not plugged into the electrical outlet.	Make sure the electrical plug is plugged into a live, properly grounded outlet.
	A fuse in your home may be blown or a circuit breaker may have tripped.	Replace the fuse or reset the circuit breaker.
	The gas supply is not properly connected or turned on.	See the Installation Instructions that came with your range.
A surface burners do not light.	The control knob is not set properly.	Push in the control knob and turn it to the LITE position.
	The burner caps are not in place. The burner base is misaligned.	Clean the electrodes. Put the burner cap on the burner head. Align the burner base
A surface burner clicks during operation.	The control knob has been left in the LITE position.	After the burner lights, turn the control knob to a desired setting. If the burner still clicks, contact a service technician.
The burners do not burn evenly	The surface burner components and caps are not assembled correctly and level.	See page 21.
	The surface burners are dirty.	Clean the surface burner components. (See page 21.)
Very large or yellow surface burner flames.	The wrong burner orifice is installed.	Check the burner orifice size and contact your installer if you have the wrong orifice (LP gas instead of natural gas or natural gas instead of LP gas).
The surface burners light but oven burners do not light	The oven door lock is turned on.	The display will show the Lock icon. Hold the oven door open and press the START/SET button for 3 seconds. The oven will beep and the Lock icon will turn off.
		Call a qualified service technician.

The Gas Pressure
Regulator shut off switch
is in the off position.

Oven



Problem	Possible cause	Action
The oven control beeps and displays an information code.	There may be a malfunction. See the "Information codes" chart on page 28.	Press the OFF/CLEAR button and restart the oven. If the problem persists, disconnect all power to the range for at least 30 seconds, and then reconnect the power. If this does not solve the problem, call for service.
Very large or yellow oven burner flames.	The oven burner air adjustment shutters need to be adjusted.	Call for a qualified service technician.
	The gas supply is not properly connected or turned on.	See the Installation Instructions that came with your range.
The oven temperature is too hot or cold.	The oven thermostat needs adjustment.	See page 19.
The oven burner will not shut off.	The oven door lock is turned on.	The display will show the Lock icon. Hold the oven door open and press the START/SET button for 3 seconds. The oven will beep and the Lock icon will turn off.
	The Sabbath function has been activated.	SAb and the time of day will show in the display. All other controls and signals will be deactivated. To turn off the oven only, press the OFF/ CLEAR button. To cancel the Sabbath function and reactivate the controls and signals, hold down Bake and  (Up) simultaneously for 3 seconds.
The oven light (lamp) will not turn on.	The oven door lock is turned on.	The display will show the Lock icon. Hold the oven door open and press the START/SET button for 3 seconds. The oven will beep and the Lock icon will turn off.
	The Sabbath function has been activated.	SAb and the time of day will show in the display. All other controls and signals will be deactivated. To cancel the Sabbath function and reactivate the controls and signals, hold down Bake and  (Up) simultaneously for 3 seconds
		See page 23.

	A loose or burned-out bulb.	
	The switch operating the oven light needs to be replaced.	Call for a qualified service technician.
The oven smokes excessively during broiling.	Meat or food was not properly prepared before broiling.	Cut away excess fat and/or fatty edges that may curl.
	Improperly positioned top oven rack.	See the broiling guide on page 16.
	The controls are not being set properly.	See page 15.
	Greasy buildup on oven surfaces.	Regular cleaning is necessary when broiling frequently.
Crackling or popping sound.	This is normal.	This is the sound of the metal heating and cooling during any cooking or cleaning function.
Steam or smoke is coming from under the control panel.	This is normal.	The oven vent is located there. More steam is visible when using the convection functions or when baking or roasting multiple items at the same time.
Burning or oily odor coming from the vent.	This is normal for a new oven and will disappear within 1/2 hour of the first bake cycle	To speed the process, remove all food from the oven, and then set it to Bake at 550 °F for a minimum of 1 hour.
Strong odor.	This is temporary.	The insulation around the inside of the oven emits an odor the first few times the oven is used.
The oven racks are difficult to slide.	This is normal.	Apply a small amount of vegetable oil to a paper towel and wipe the edges of the oven racks with the paper towel.

Others

Problem	Possible cause	Action
The product is not level.	The appliance has been installed improperly. The leveling leg(s) is (are) damaged or uneven.	Make sure the floor is level, strong, and stable. If the floor sags or slopes, contact a carpenter. Check and level the range. (See the Installation Instructions.)
	The kitchen cabinets are not properly aligned and make the range appear to be not level.	Ensure that cabinets are square and provide sufficient room for installation.
The display goes blank.	The electrical outlet Ground Fault Interrupter (GFI or GFCI) has been tripped and needs to be reset. Your digital control has been damaged.	Replace the fuse or reset the circuit breaker.
Food does not bake or roast properly in the oven.	The wrong cooking mode is selected.	See page 15.
	The oven racks have not been positioned properly for the foods being cooked.	See page 16.
	Incorrect cookware or cookware of improper size is being used.	See page 12.
	The oven thermostat needs adjustment.	See page 19.
	There is aluminum foil on the racks and/or oven bottom.	Remove the foil.
	The clock or timers are not set correctly.	See page 11.
Food does not broil properly in the oven.	The oven controls are not set properly.	See page 15.
	The oven door was not closed during broiling.	See page 15.
	The rack has not been properly positioned.	See the broiling guide page on 16.

Information codes

Code symbol	Meaning	Solution
C-20	Check the oven sensor	1. Press the OFF/CLEAR button, and then restart the oven. 2. If the problem persists, disconnect all power to the range for at least 30 seconds, and then then reconnect the power.
C-21	Oven overheating.	
C-30	Check the PBA NTC Sensor.	
C-31	Check the PBA NTC Sensor.	
C-F0	Check the PCB signals.	
C-d0	Check the control panel pads	

**** If these solutions do not solve the problem, contact a local Samsung service center 1-800-SAMSUNG (1-800-726-7864).**

Warning

This content is compiled from multiple sources and is provided for reference purposes only. It may not be complete or fully applicable to all situations. If you are unable to resolve your issue, please contact the product manufacturer or an authorized service provider for official support.