

Installation

Your refrigerator at a glance

NOTE: Your refrigerator and the provided component parts of your refrigerator may differ from the illustrations in this manual, depending on the model and your country.

- 01 Auto Ice Maker (Ice Master)
- 02 EZ Fresh Vegetable & Fruit Drawers
- 03 Fridge Multi-Purpose Guard
- 04 Easy Slide-Shelf
- 05 Dry Food and Meat Storage Drawers
- 06 Freezer door Bins
- 07 Quick Space Shelf
- 08 Water filter
- 09 Wine Rack
- A. Fridge
- B. Freezer
- C. FlexZone

NOTE

- For energy efficiency, keep all shelves, drawers, and baskets in their original positions.
- When closing the door, make sure the vertical hinged section is in the correct position to avoid scratching the other door.
- If the vertical hinged section is reversed, put it back into the correct position, and then close the door.
- Moisture may form at times on the vertical hinged section
- If you close a door forcefully, the other door may open.
- When the door is opened, the interlock switch automatically disables the auger motor of the ice maker for safety reasons.
- If the internal or external LED lamp is out of order, contact a local Samsung service center.

Door bins

Your refrigerator ships with door bins of different types and sizes. If the door bins for your refrigerator were packaged separately, use the figure below to help you position the bins properly. The number of door bins provided may differ with the model.

Door removal for entrance

If the refrigerator cannot pass through the entrance to your home or kitchen due to its size, follow these instructions to remove and then re-install the refrigerator's doors. If you do not need to remove the doors, go to page 28 for the installation instructions.

Tools required (not provided)

Detaching the fridge doors

1. With the door closed, use a Phillips head screwdriver to remove the screws (x3) from the top cover. Pull up and remove the top cover with the connectors.
2. Disconnect the two wire connectors on the left door. The position of the connectors differs with the model.
3. Disconnect the water tube from the coupler on the left door as shown.
4. Gently draw up the clamp in several steps. To prevent finger injuries, do not apply a sudden force to the clamp.
5. Pull up the clamp to remove.
6. Open the door 90 degrees. While holding the door, pull up and remove the top hinge. Be careful not to damage the connector wires when you remove the hinge.
7. Gently pull up the door vertically to remove. Do not apply excessive force to the door. The door may fall, causing physical injury.
8. Lay the door down on a flat surface.
9. Repeat the steps above for the other door, except for Step 3. There is no water tube on the right side door.

Detaching the freezer doors

1. With the freezer door open, use a Phillips head screwdriver to remove the screw holding the cover (A) of the adjustable leg.
2. Disconnect the wire connectors.
3. Locate the hinge shaft. While holding the door with one hand, use a flat-head screwdriver or wrench to press the shaft down. Make sure to hold the door to prevent the door from falling.
4. To prevent contact with the middle hinge, slightly tilt the door to the front, and then lift it up to remove.
5. Repeat the steps above for the other door.

Re-attaching the freezer doors

CAUTION

- Before re-attaching the doors, make sure all the electrical connectors are properly connected.
- The freezer doors must be re-attached before the fridge doors.
- Be careful not to damage or step on the wires during this process.

1. Insert the freezer door into the bottom hinge while pushing the freezer door in the direction of the arrow.

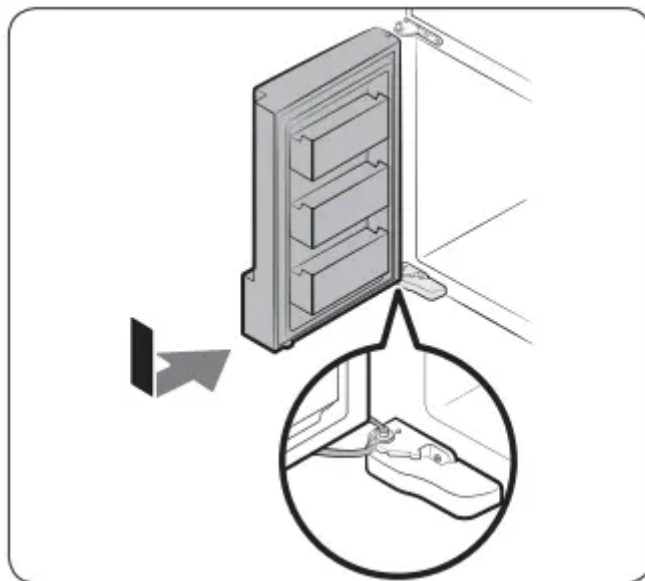

CAUTION

- Be careful not to damage or step on the wires during this process.

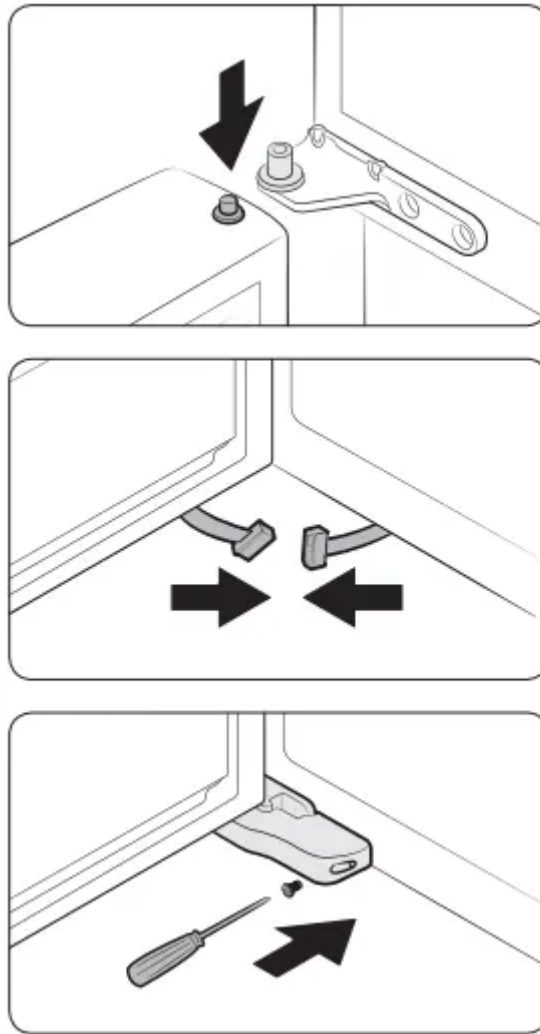

2. While pressing the hinge shaft down, position the door so that the hinge shaft is below the shaft hole in the middle hinge. Release the hinge shaft so that it enters the shaft hole.
3. With the door open, connect the bottom connectors in the direction of the arrows.
4. Attach the levelling foot cover using a Phillips head screwdriver. Be careful not to damage or step on the connectors.
5. Repeat the steps above for the other door.

Re-attaching the fridge doors

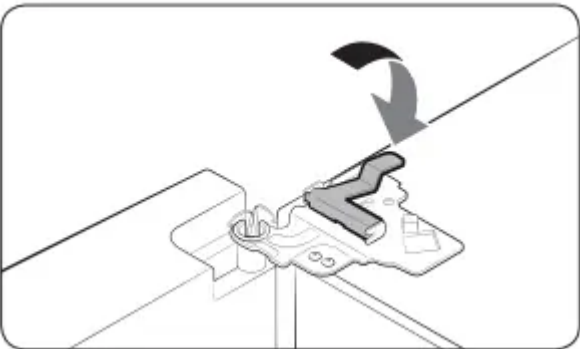
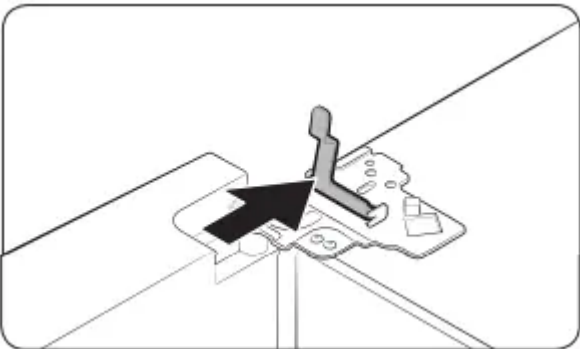
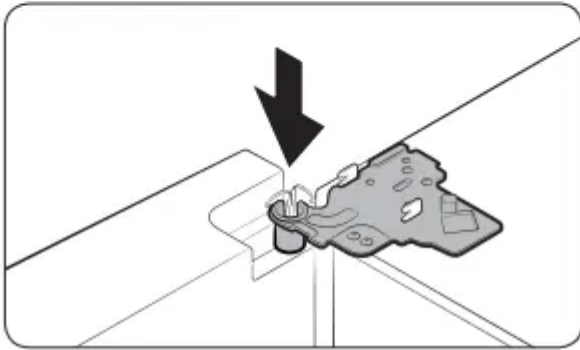
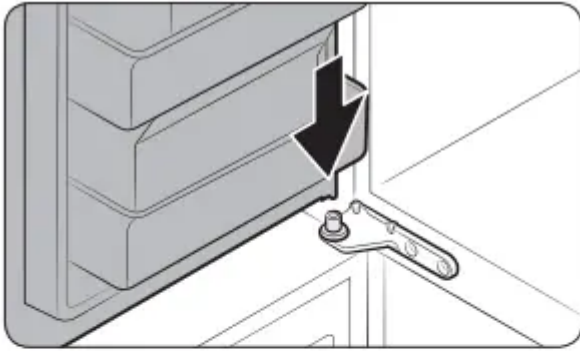

1. While holding the door open by more than 90 degrees, insert the shaft on the middle hinge into the hole on the bottom of the door.
2. Put the top hinge into position on the top of the refrigerator, and then insert the hinge shaft into the top hole of the door. Make sure the wires from the door pass through the hole in the hinge shaft.
3. Insert the clamp in the direction of the arrow.

4. Push back the clamp as shown.

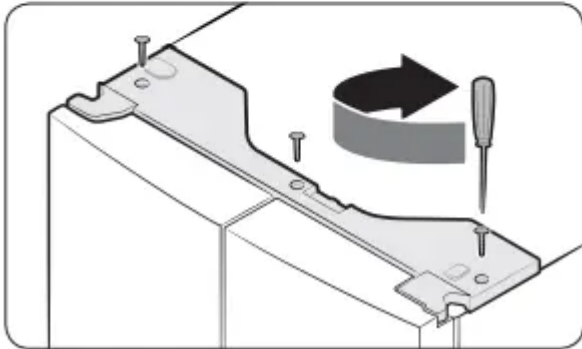
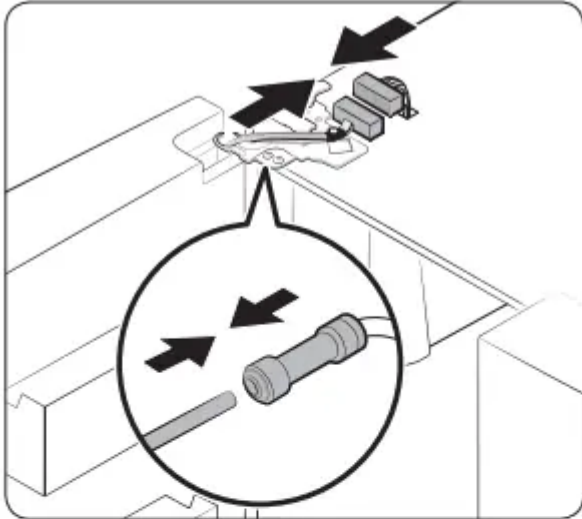

5. Connect the wire connectors.

CAUTION

- Make sure the wire connectors are connected properly. Otherwise, the display will not operate.

6. Connect the water tube.

CAUTION

- To prevent water leaks, make sure the red clips tighten the coupler properly.
- Keep the clips out of children's reach.

7. Repeat the above steps for the other door, except for Step 6. The right door does not have a water tube.

8. Attach the top cover with the front side first, and then press down on its back to get it into position. Then, tighten the screws (x3).

Step-by-step installation

STEP 1 Select a site



The site must:

- Have a solid level surface without carpeting or flooring that may obstruct ventilation
- Be out of direct sunlight
- Have adequate room for opening and closing the door
- Be away from any heat source
- Provide room for maintenance and servicing
- Have a temperature range between 50 °F (10 °C) and 110 °F (43 °C)

Clearance

See the pictures and table below and on the next page for installation space requirements.

NOTE

The measurements of your refrigerator may differ from those listed above, depending on the measuring method.

STEP 2 Flooring

- The surface of the installation location must support a fully loaded refrigerator.
- To protect the floor, put a large piece of cardboard under each leg of the refrigerator when you move it for installation.
- To protect the floor once the refrigerator is in its final position, do not move it unless necessary. If you have to move it, place thick paper or cloth such as an old carpet, along the movement path.

STEP 3 Adjust the levelling feet

Level the refrigerator using the special screws (levellers) on the front legs. Use a flat-head screwdriver to turn the levellers.

- To adjust the height of the left side: Insert a flat-head screwdriver into the leveller of the left side front leg. Turn the leveller clockwise to raise or turn it counterclockwise to lower.
- To adjust the height of the right side: Insert a flat-head screwdriver into the leveller of the right side front leg. Turn the leveller clockwise to raise or turn it counterclockwise to lower.

STEP 4 Adjust the door height as well as the door gap

Snap ring

- The height of a door can be adjusted using the provided snap rings, which come in 4 different sizes (1 mm, 1.5 mm, 2 mm, and 2.5 mm).

To adjust the height of a door

1. Check the height difference between the doors, and then raise and hold the lower door.

2. Insert a suitable-sized snap ring (A) between the door and the hinge as shown.

To correct the door gap

Door gaps can be corrected using the gap bolt on the top right corner of the refrigerator.

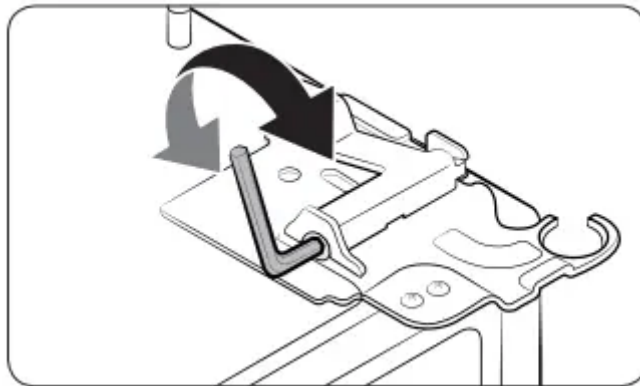
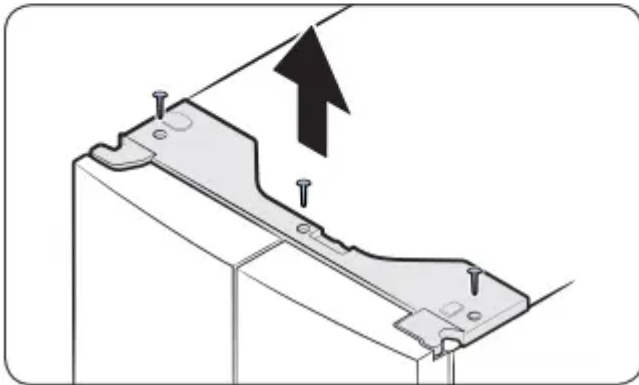
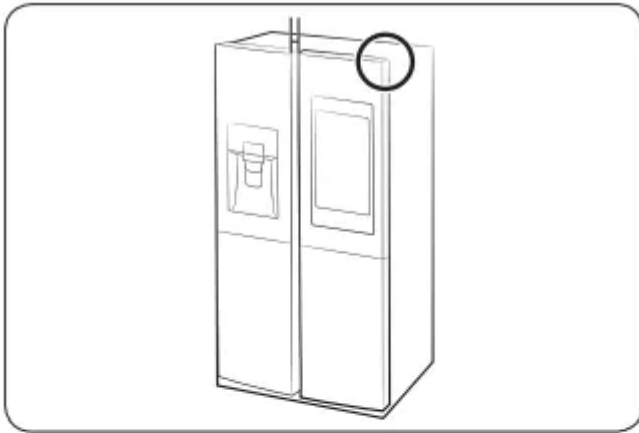

1. With the door closed, use a Phillips head screwdriver to remove the screws (x3) in the top cover. Then, carefully remove the top cover along with the wire connectors.
2. Use a 4 mm Allen wrench (not provided) to correct the door gap between two doors.
 - To widen the gap, turn the gap bolt clockwise.
 - To narrow the gap, turn the gap bolt counterclockwise.
3. When done, reinsert the top cover, and then reinsert the screws that hold it in place. Tighten the screws.

STEP 5 Connect the water dispenser line

A water dispenser with a filter is one of the helpful features on your new refrigerator. To help promote better health, the water filter removes unwanted particles from your water. However, it does not sterilize or destroy microorganisms. You may need to purchase a water purifying system to do that.

The water line also connects to the ice maker. For the ice maker to operate properly, a water pressure of 20-125 psi is required.

If the refrigerator is installed in an area with low water pressure (below 20 psi), you can install a booster pump to compensate for the low pressure.

After you have connected the water line, make sure the water storage tank inside the refrigerator is properly filled. To do this, press the water dispenser lever until the water runs from the water outlet.

WARNING

- Keep ventilation openings, in the appliance enclosure or in the built-in structure, clear of obstruction. Connect to potable water supply only.

1. Shut off the main water source.
2. Insert the pipe clamp (B) and the shut off valve (C) into the cold water line (A).
3. Connect the water line installation kit (A) to the shut off valve (B)

Connect the water supply line to the refrigerator

There are several items you must purchase to complete this connection. You may find these items sold as a kit at your local hardware store.

A. Refrigerator

B. Household water supply line

01 Compression Nut (1/4") (Assembled)

02 Ferrule (Not supplied)

03 Copper tubing (Not supplied)

04 Plastic Tubing (Assembled)

05 Compression Fitting (Assembled)

06 Molded end (Bulb)

07 Compression nut (B) (1/4") (Not supplied)

08 Plastic Tubing (A) (Not supplied)

1. Connect the household water line to the assembled compression fitting.
 - If you are using copper tubing, slip the compression nut (B) (not supplied) and ferrule (not supplied) on the copper tubing (not supplied) as shown.
 - If you are using plastic tubing (A), insert the molded end (Bulb) of the plastic tubing (A) into the compression fitting.
2. Tighten the compression nut (B) onto the compression fitting. Do not over-tighten the compression nut (B).
3. Turn the water on and check for any leakage. If you find water drops or leakage in the connection areas, turn off the main water supply. Check the connections and, if necessary, tighten.
4. Flush 1 gallon of water through the filter before drinking or using the water from the refrigerator. (Flush approximately 6 minutes.) To flush, press a large glass or cup against the water dispenser lever. Fill the glass, empty it, and then repeat.
5. After you turn on the refrigerator, let the ice maker make ice for 1 to 2 days. Over that period of time, throw out the first 1 or 2 buckets of ice the ice maker makes to ensure all impurities have been removed from the water line.

STEP 6 Initial settings

After you complete the following steps, the refrigerator should be fully functional.

1. Plug the power cord into the wall socket to turn the refrigerator on.
2. Open the door, and check if the interior light lights up.
3. Set the temperature to the coldest setting, and then wait for about an hour. Then, the freezer will be slightly chilled, and the motor should be running smoothly.
4. Wait until the refrigerator reaches the set temperature. Now the refrigerator is ready to use.

STEP 7 Final check

When installation is complete, confirm that:

- The refrigerator is plugged into an electrical outlet and grounded properly.
- The refrigerator is installed on a flat, level surface with appropriate clearance between it and any walls or cabinets.
- The refrigerator is level and is sitting firmly on the floor.
- The door opens and closes freely, and the interior light turns on automatically when you open the door.

Operations

User interface

NOTE

- For detailed information about the refrigerator's functions, and apps, see the on-screen user manual available on the LCD display of your refrigerator.
- The content of apps and widgets and their design is subject to change. Support for apps and widgets may be discontinued without notice, depending on the content provider's policy.
- Children's use of the refrigerator's functions, apps, and services must be supervised by adults.
- The PANDORA apps are only available in the United States.



01 Home screen

02 Soft buttons

01 Home screen



01 Apps & Widgets

- Tap a desired app or widget to launch it.
- Tap and hold an app or widget to enter Edit mode. A grid appears. In Edit mode, you can drag and drop an app or widget to a new position on the grid. When you move the app or widget to a new grid location, the location turns blue if it is available. If it is not available, it turns red.
- You can add an app or widget that has been removed from the Apps list.

02 Status bar

- Displays the status of various functions. (Refer to the following Icon descriptions table.)

Icon descriptions

Bluetooth (📶)	Indicates Bluetooth connection status.
USB (📁)	Indicates USB connection status. NOTE The refrigerator supports USB memory that is formatted in the FAT32 or exFAT file systems. NTFS is not supported. Be sure to convert NTFS to FAT32 or exFAT before use.
Remote Management (🔌)	Turns on when Remote Management is enabled and running.
Network (📶)	Indicates network connection status in 5 levels (Off, 1-4).
Software Update (🔄)	Indicates that the newest version of the refrigerator's software has been downloaded from the server and is ready to update.

Notification (🔔)	Indicates there is a notification message.
Cloud sync (☁️)	Indicates Family Hub is receiving data from the cloud server.

02 Soft buttons



01 Microphone

- Tap to turn the microphone on or off.

02 Task Manager

- Tap to open the Task Manager.
- See the Task Manager section for details.

03 Home

- Tap to open the Home screen.

04 Return

- Tap to return to the previous screen.

05 Notification

- Tap to display the Quick Panel.

06 Hide/Show

- Tap to hide or show Soft buttons.
- The Hide/Show button only appears when an app is active.

Fridge Manager

To access Fridge Manager, swipe the Home screen to the left, and then tap the Fridge Manager widget.

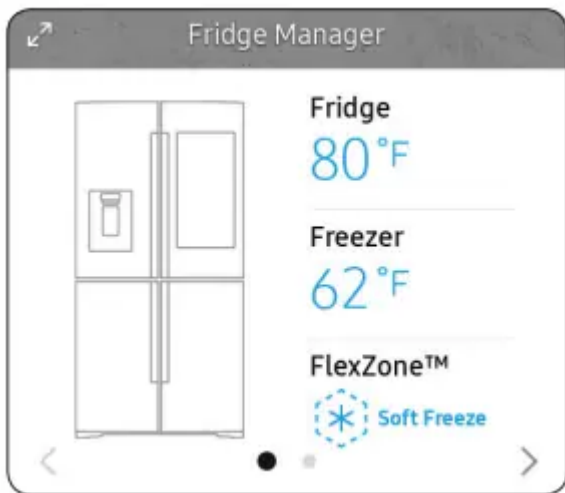

- Tap < or > on the bottom of the widget to move between pages.
- On the first page, you can check the current temperatures or modes of each compartment as well as active special functions.
- Tap the first page to open the Fridge Manager for detailed settings.
- On the second page, you can check the filter status.
- Tap Buy Filter on the second page to open the website where you can purchase a water filter.

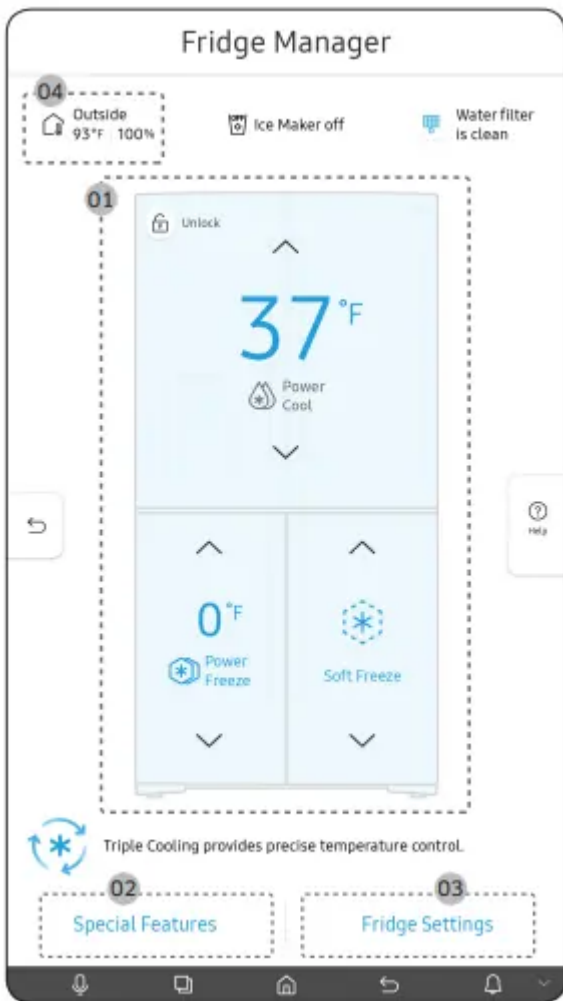

The Fridge Manager is a graphical representation of your refrigerator. The top half represents the refrigerator compartment, the bottom left the freezer compartment, and the bottom right the FlexZone. The temperature or mode settings for each are displayed over each section.

Fridge Manager At a Glance

01 Temperature

Change the set temperature in the fridge, freezer, and FlexZone. You can also turn on and turn off the refrigerator's Power Cool function and the freezer's Power Freeze function.

- Power Freeze speeds up the freezing process at maximum fan speed. The freezer keeps running at full speed for several hours and then returns to the previous temperature.

- To freeze large amounts of food, activate Power Freeze at least 20 hours before putting food in the freezer.

NOTE

Using Power Freeze increases power consumption. Make sure you turn it off so the freezer returns to its previous temperature if you do not need it any longer.

02 Special Features View a short explanation of some of the refrigerator's special features.

03 Fridge Settings Change many of the fridge's settings including settings for ice making, the door alarm, and the temperature units (°F or °C). See the next page for details.

04 External Conditions Displays the external (ambient) temperature and humidity.

Display reset (applicable models only)

If the display is not working correctly, try resetting the display. This may resolve the problem.

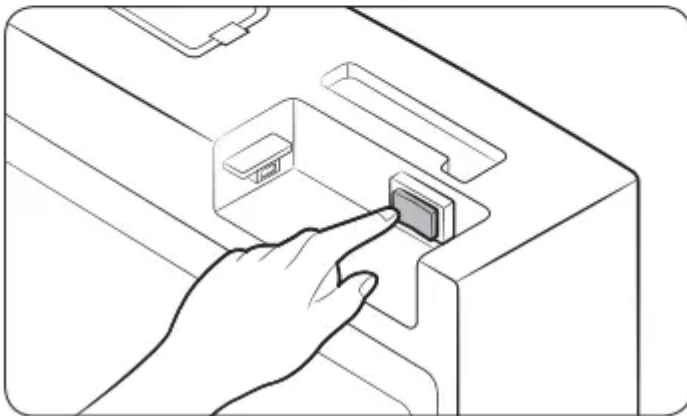
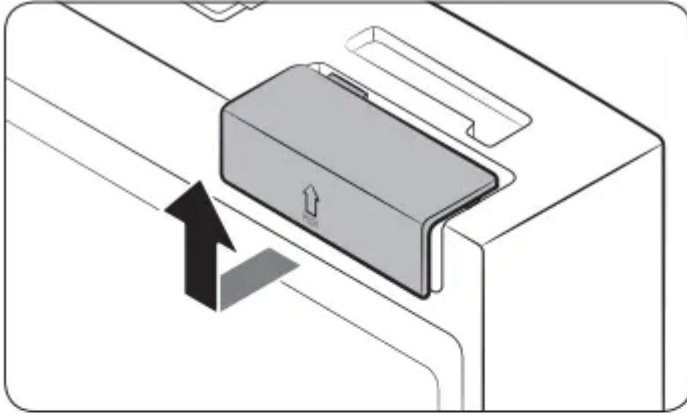

1. Open the right-side fridge door and locate the switch cover on the top right corner of the door.
2. Push up the cover to reveal the power switch.
3. Turn the switch off, and then turn it on again.
4. Reinsert the switch cover. You will hear a click when the cover is in place.

SmartThings

Installation

Visit the Google Play Store, Galaxy Apps, or Apple App Store and search for “SmartThings”.

Download and install the SmartThings app provided by Samsung Electronics to your smart device.

NOTE

- The SmartThings app is designed for Android 6.0 (Marshmallow) or later, iOS 10.0 or later, iPhone 6 or later, and is optimized for Samsung smartphones (Galaxy S and Galaxy Note series).
- For improved performance, the SmartThings app is subject to change without notice or discontinued support according to the manufacturer's policy.
- Recommended encryption systems include WPA/TKIP and WPA2/AES. Any newer or non-standard Wi-Fi authentication protocols are not supported.
- Wireless networks may be affected by the surrounding wireless communication environment.
- If your Internet service provider has registered the MAC address of your PC or modem for identification, your Samsung Smart Refrigerator may fail to connect to the Internet. If this happens, contact your Internet service provider for technical assistance.
- The firewall settings of your network system may prevent your Samsung Smart Refrigerator from accessing the Internet. Contact your Internet service provider for technical assistance. If this symptom continues, contact a local Samsung service center or retailer.
- To configure the wireless access point (AP) settings, see the user manual of the AP (router).
- Samsung Smart Refrigerators support both Wi-Fi 2.4 GHz with IEEE 802.11 b/g/n and Soft-AP protocols. (IEEE 802.11 n is recommended.)
- Unauthorized Wi-Fi wireless routers may fail to connect to applicable Samsung Smart Refrigerators.

Samsung account

- You are required to register your Samsung account to use the app. If you don't have a Samsung account, follow the app's onscreen instructions to create a free Samsung account

Getting started

Turn on the device you want to connect, open the SmartThings app on your phone, and then follow the instructions below.

If a pop-up appears saying that a new device has been found, tap ADD NOW.

If a pop-up doesn't appear, tap the + button, and then select the device you want to connect from the list of available devices.

If your device isn't in the list of available devices, tap Supported Devices, select the device type (Refrigerator), and then select the specific device model.

Follow the instructions in the app to set up your device. Once setup is complete, your refrigerator will appear as a "card" on your Devices screen.

Refrigerator app

Integrated control

You can monitor and control your refrigerator at home and on the go.

Tap the refrigerator icon on the SmartThings Dashboard or tap the Devices icon at the bottom of the Dashboard, and then tap the refrigerator "card" to open the Refrigerator page.

Check the operation status or notifications related to your refrigerator, and then change options or settings if necessary.

NOTE Some options or settings of the refrigerator may not be available for remote control.

Category	Item	Description
Monitoring	Fridge temperature	Displays the current temperature setting of the fridge.
	Freezer temperature	Displays the current temperature setting of the freezer.
	FlexZone™ settings	Displays the settings of the FlexZone™.
	Self Check	Detects abnormal operations of the refrigerator.
	Energy monitoring	Checks the accumulated power consumption of the refrigerator for the last 180 days.
Functions	Ice making	You can turn the ice making function on or off, and check the current settings of the function.
		You can also check the status and progress of ice making.
	Power Cool	You can turn Power Cool on or off, and check the current settings.
	Power Freeze	You can turn Power Freeze on or off, and check the current settings.

Alarms	Abnormally high temperature	This alarm is triggered when the fridge, the freezer, or the FlexZone™ has abnormally high temperatures.
	Door opening	This alarm is triggered if the fridge or freezer door or the FlexZone™ door is left open for a specific length of time.
	Water filter replacement	This alarm reminds you that the water filter must be replaced.
Inside Image		You can view the inside of the refrigerator and can see if you need to replace food items.
Family Hub App Link		You can connect to the App Store and download the Refrigerator app.

Special features

Water dispenser

With the water dispenser, you can dispense water without opening the fridge door.

The water dispenser offers 3 options: chilled water, cubed ice, and crushed ice. If you do not want to dispense ice, simply press the water lever (B).

With the Ice Maker enabled,

1. Press to select an ice type.
2. Put a water glass on the ice lever (A) and push it. Ice is dispensed from the dispenser.
3. If you want water, put the glass on the water lever (B) and push it. Water is dispensed from the dispenser.

NOTE

- To get ice and water, push the ice lever (A) first for ice, then move your glass down and press the water lever (B) for water.
- If you push both levers at once, only the first pushed lever operates.
- To prevent spills, wait 1 second before removing the glass after dispensing.
- Make sure the glass is in line with the dispenser to prevent the dispensed water from spilling out.
- If you do not use the water dispenser for 2-3 days, the dispensed water may have an abnormal smell or taste. This is not a system failure. Discard the first 1-2 glasses of water.

Ice maker

The refrigerator has a built-in ice maker that automatically dispenses ice so that you can enjoy filtered water with cubed or crushed ice.

Ice making

After you have installed your refrigerator and plugged it in, follow these instructions to ensure proper ice making and to keep the ice bucket full of ice:

1. Let the refrigerator run at least 24 hours without dispensing ice for optimal performance.
2. Dispense the first 4 to 6 ice cubes into a glass.
3. Wait another 8 hours and dispense another 4 to 6 ice cubes.
4. Then, wait another 16 hours and dispense the first glass-full of ice.

Diagnosis

If ice does not dispense, first check the ice maker. To check the ice maker

1. Press Test on the side of the ice maker. You will hear a chime (ding-dong) when you press the button.
2. You will hear another chime if the ice maker is operating properly.

Ice Maker Off

To disable the icemaker, tap Fridge Manager > Fridge Settings > Ice Maker on the Home screen, and then select Off. Make sure to empty the ice bucket. Remaining ice cubes may clump together, making it difficult to remove them.

To remove the ice bucket

1. Hold the bottom of the ice bucket with one hand and hold the side with the other hand.
2. Gently lift it up and pull out.
3. Remove the remaining ice cubes, and then put the ice bucket back into place.

If the bucket does not fit in, turn the helix screw 90 degrees, and then try again.

Water clouding

- Water supplied to the refrigerator flows through a core alkaline filter. During this filtering process, the water pressure of the water increases and the water becomes saturated with oxygen and nitrogen. This causes the water to look misty or cloudy temporarily when dispensed. This is normal and the water will look clear after a few seconds.

Wine Rack

The refrigerator ships with a wine rack, which can be positioned in one of 3 positions: under the shelf, in the partition guide, or on top of the sliding shelf of the FlexZone. The position or positions available to you depends on your model.

CAUTION

When you remove or insert the wine rack, make sure that the wine rack is empty.

Under the shelf

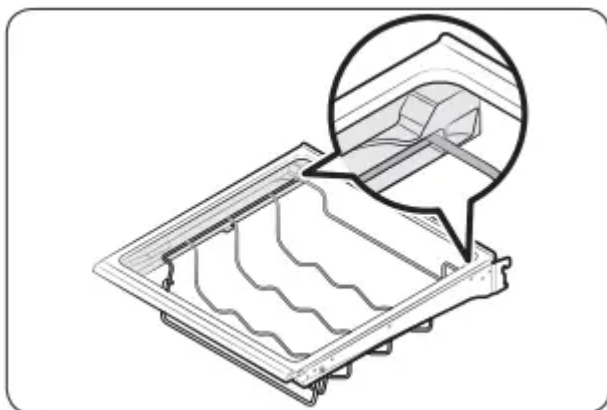

Insert the wine rack under the shelf of the fridge. Make sure to insert it all the way to the end as shown in the figure.

In the partition guide

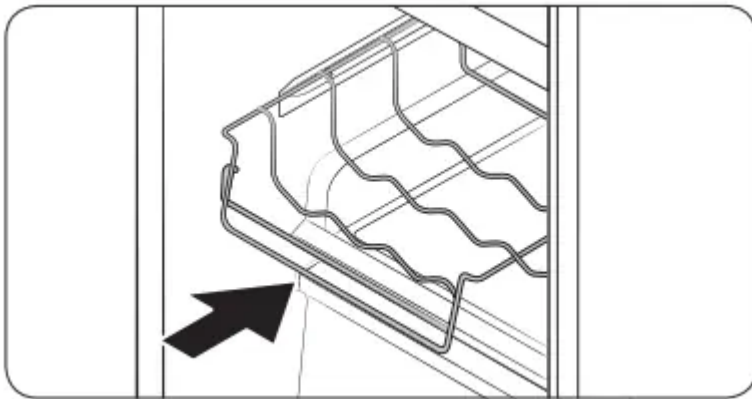

Insert the wine rack in the partition guide of the FlexZone.

- Make sure the front of the wine rack fits in the partition guide on the inner left-hand side of the FlexZone.
- Set the temperature of the FlexZone to White Wine.

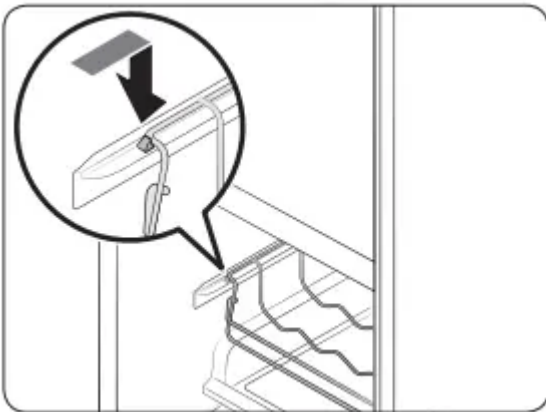

On the sliding shelf

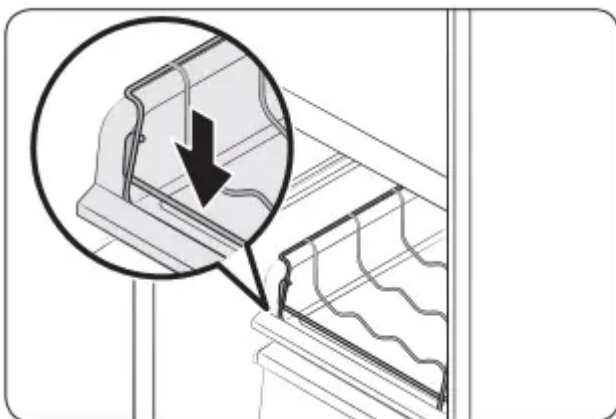

Insert the wine rack on top of the sliding shelf of the FlexZone, which is normally below the partition guide.

- Set the temperature of the FlexZone to White Wine.

Maintenance

Handling and care

Ice bucket

If you do not dispense ice for an extended period, ice may form clumps inside the bucket. If this happens, remove and empty the ice bucket.

1. To remove the ice bucket, gently lift it up, and then pull it out slowly while holding the bottom of the bucket with one hand and the side with the other hand.
2. Empty the bucket.
3. When done, put the bucket back into position. If the bucket does not fit in, turn the helix screw 90 degrees, and then try again.

Tempered glass shelves (fridge)

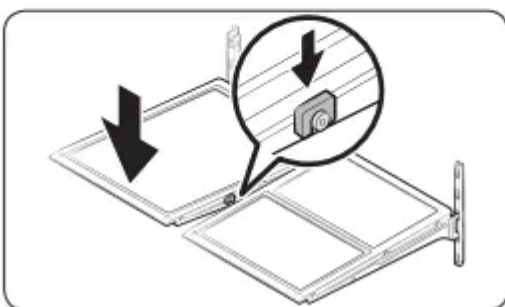
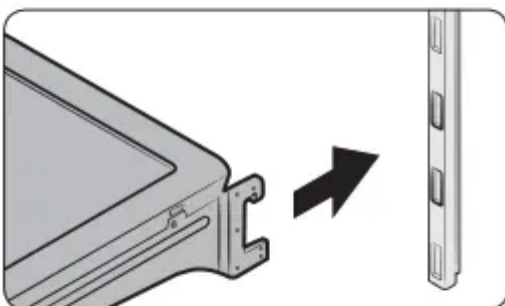
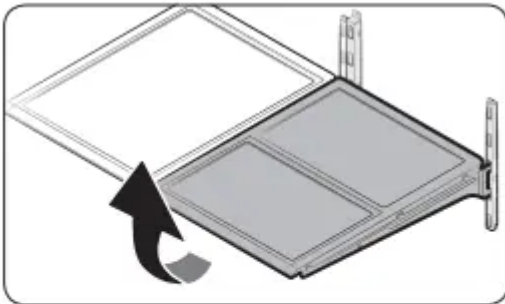

- To remove a shelf, fully open the corresponding door. Hold the front of the shelf, and then gently lift up and slide out.
- To reinsert, hold the shelf at an angle so the front is higher than the back, and then insert the top hook into the top shelf notch. Then, lower the shelf and insert the bottom shelf hook into the bottom shelf notch.

CAUTION

- The tempered glass shelves are heavy. Use caution when removing them.
- The shelf must be inserted correctly. Do not insert upside down.
- Glass containers may scratch the surface of glass shelves.

Door bins

The top door bin section has a marked line to ensure easy removal and proper reinsertion.

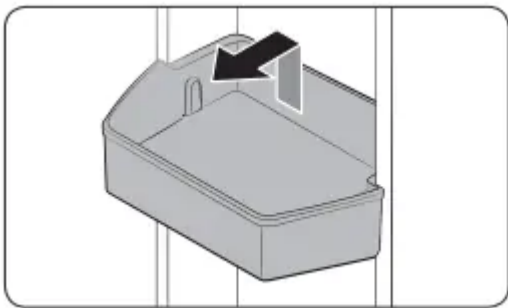

Lift up the door bin, and then pull out straight.

CAUTION

Do not allow children to play with the bins. Sharp-edged corners may cause injury.

Vegetable & fruit drawers (EZ fresh zone)

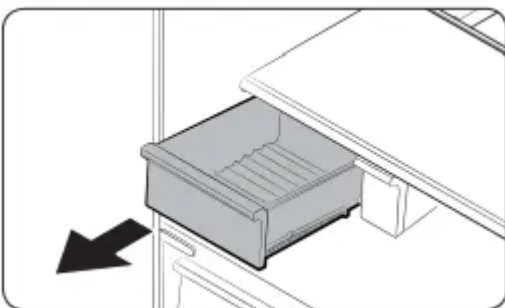

Gently lift up the front of the drawer and slide out.

We recommend that you remove the door bins before removing the drawer. This is to prevent damage to the door bins.

Vegetable shelf

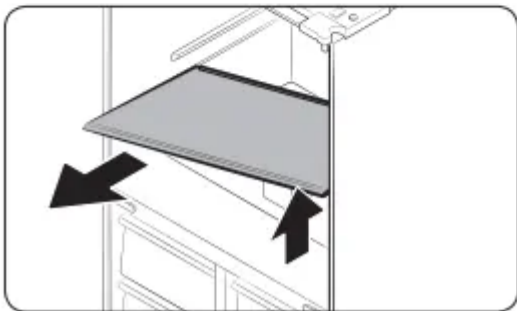
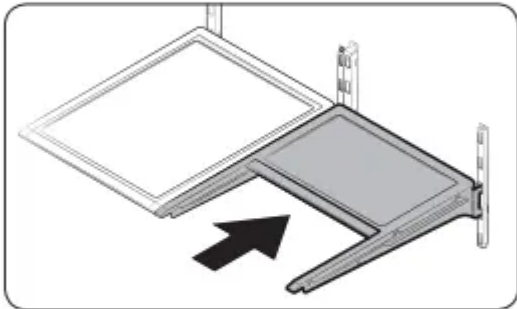
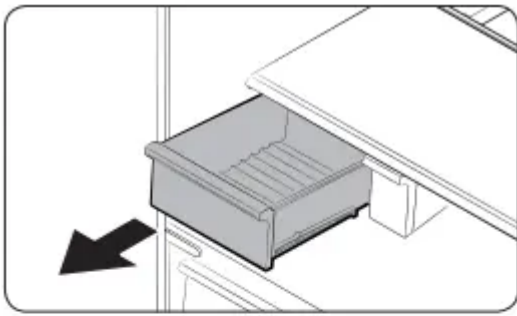

1. Slide out the left-side vegetable drawer.
2. Slide in the right-side foldable shelf.
3. While supporting the vegetable shelf with one hand, slide it out with the other hand.

NOTE

To use the space that is opened up after removing the foldable shelf, take out the vegetable shelf.

To reinsert, follow the steps above in the reverse order.

Ice bucket

To remove the ice bucket, see the Maintenance section on page 61

Cleaning

Interior and exterior

WARNING

- Do not use benzene, thinner, home/car detergent, or Clorox™ to clean the refrigerator. They may damage the surface of the refrigerator or cause a fire.

- Do not spray water onto the refrigerator. This may cause electric shock.
- Do not put fingers or any objects into the dispenser outlet.

CAUTION

- Do not spray water directly on the LCD display or speaker. This may cause fire, electric shock, or damage.
- Do not scratch the LCD display or speaker. This may cause permanent damage

Regularly use a dry cloth to remove all foreign substances such as dust or water from the power plug terminals and contact points.

To clean the refrigerator

1. Unplug the power cord.
2. Use a moistened, soft, lint-free cloth or paper towel to clean the refrigerator's interior and exterior.
3. When done, use a dry cloth or paper towel to dry well.
4. Plug in the power cord.

Inner-view camera

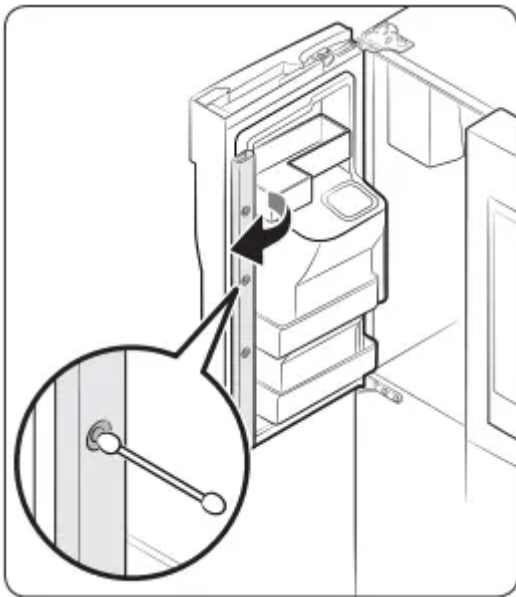

NOTE Use a cotton swab or microfiber cloth to clean the camera on the left-side door of the fridge.

Water filter

WARNING

- Do not use third-party water filters. Use only Samsung-provided or -approved filters.
- Unapproved filters may leak and damage the refrigerator, causing electric shock. Samsung is not responsible for any damage that may occur from use of third-party water filters.

The filter indicator () turns red to let you know it is time to replace the water filter. Before replacing the filter, make sure the water supply line is shut off.

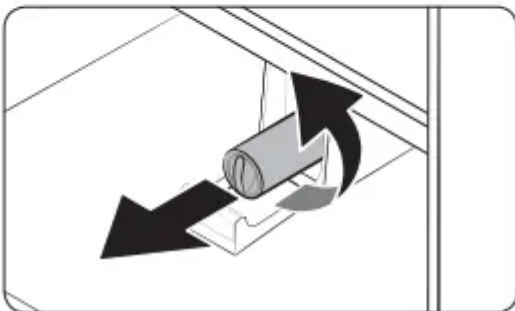
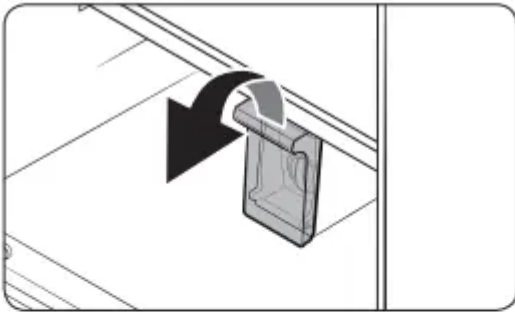

1. Open the filter cover.

- Some models may not have a filter cover. If your model does not, skip this step.

2. Turn the knob of the filter cartridge counter clockwise 90 degrees (1/4 turn). The filter cartridge unlocks.

3. Pull out to remove the cartridge.

- If the water filter is severely contaminated, the cartridge may not be easy to remove. If that is the case, use force to remove the cartridge.

- To prevent water leaks from the filter opening, pull the cartridge straight out while removing it.

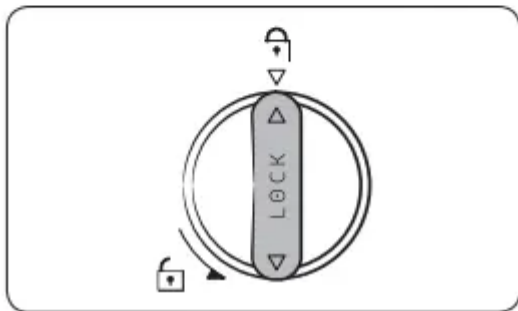
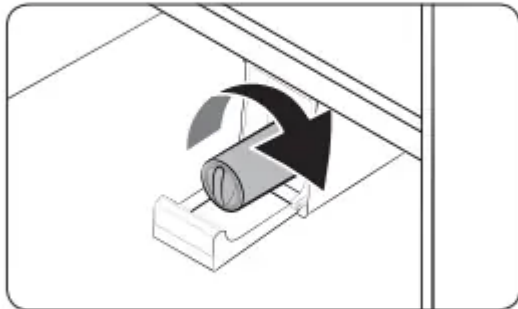
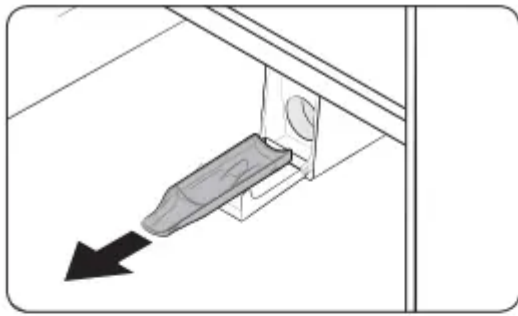

NOTE To prevent overflow, empty and dry the water filter tray.

4. Insert a new filter cartridge. Use only Samsung-provided or approved filters.
5. Turn the cartridge knob clockwise to lock into place.
6. On the Home screen, tap Fridge Manager > Fridge Settings > Water Filter, and then select Reset. The filter indicator turns off.
7. When you are done replacing the filter, open the water valve and run water through the dispenser for about 7 minutes. This is to remove impurities and air from the water line.

Reverse osmosis water filtration system

The water pressure of the water supply system to a reverse osmosis water filtration system must be between 35 psi and 120 psi (241 kPa and 827 kPa). The water pressure of the reverse osmosis water filtration system to the refrigerator's cold water line must be at least 40 psi (276 kPa). If the water pressure is below these specifications:

- Check if the sediment filter in the reverse osmosis system is blocked. Replace the filter if necessary.
- Refill the water tank in the reverse osmosis system with water.

- If your refrigerator has a water filter, it may further reduce the water pressure when used in conjunction with a reverse osmosis system. Remove the water filter.

For more information or servicing, contact a licensed plumbing professional.

Ordering a new filter

To purchase a new water filter, contact a local Samsung service center or visit www.samsungparts.com on the web.

LED Lights

To replace the LED lights on the refrigerator, contact a local Samsung service center.

WARNING

The LED lights are not user-serviceable. Do not attempt to replace an LED light yourself. This can cause electric shock.

Troubleshooting

Before calling for service, review the checkpoints below. Any service calls regarding normal situations (No Defect Cases) will be charged to users.

General

Temperature

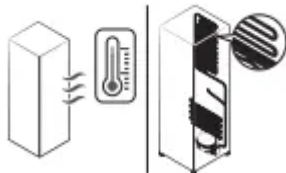
Symptom	Possible causes	Solution
Fridge/freezer does not operate. Fridge/freezer temperature is warm.	<ul style="list-style-type: none"> • Power cord is not plugged in properly. 	<ul style="list-style-type: none"> • Properly plug in the power cord.
	<ul style="list-style-type: none"> • Temperature control is not set correctly. 	<ul style="list-style-type: none"> • Set the temperature lower.
	<ul style="list-style-type: none"> • Refrigerator is located near a heat source or direct sunlight. 	<ul style="list-style-type: none"> • Keep the refrigerator away from direct sunlight or a heat source.
	<ul style="list-style-type: none"> • Not enough clearance between refrigerator and nearby walls or cabinets. 	<ul style="list-style-type: none"> • Make sure there is a gap of at least 2.5 inches (5 cm) between the refrigerator back and sides and any nearby walls or cabinets.
	<ul style="list-style-type: none"> • Energy Saver mode is activated. 	<ul style="list-style-type: none"> • Deactivate Energy Saver mode.
	<ul style="list-style-type: none"> • The refrigerator is overloaded. Food is blocking the refrigerator vents. 	<ul style="list-style-type: none"> • Do not overload the refrigerator. Do not allow food to block vents.
Fridge/freezer is over-cooling.	<ul style="list-style-type: none"> • Temperature control is not set correctly. 	<ul style="list-style-type: none"> • Set the temperature higher.
Interior wall is hot.	<ul style="list-style-type: none"> • Refrigerator has heat-proof piping in the interior wall. 	<ul style="list-style-type: none"> • To prevent condensation from forming, the refrigerator has heat-proof piping in the front corners. If the ambient temperature rises, this equipment may not work effectively. This is not a system failure. 

Odors

Symptom	Possible causes	Solution
Refrigerator has odors.	• Spoiled food.	• Clean the refrigerator and remove any spoiled food.
	• Food with strong odors.	• Make sure strong smelling food is wrapped airtight.

Frost

Symptom	Possible causes	Solution
Frost around the vents.	• Food is blocking the vents.	• Make sure no food blocks the refrigerator vents.
Frost on interior walls.	• Door is not closed properly.	• Make sure food does not block the door. Clean the door gasket.
Fruits or vegetables are frozen.	• Fruits or vegetables are stored in the Cool Select Zone.	• Do not store most kinds of fruit or vegetables in the Cool Select Zone.

Condensation

Symptom	Possible causes	Solution
Condensation forms on the interior walls.	• If door is left open, moisture enters the refrigerator.	• Remove the moisture and do not leave a door open for extended periods of time.
	• Food with high moisture content.	• Make sure food is wrapped airtight.

Water/ice (dispenser models only)

Symptom	Possible causes	Solution
Water flow is weaker than normal.	<ul style="list-style-type: none"> • Water pressure is too low. 	<ul style="list-style-type: none"> • Make sure the water pressure is between 30 to 120 psi (206 to 827 kPa).
Ice maker makes a buzzing sound.	<ul style="list-style-type: none"> • The ice maker function is activated, but the water supply to the refrigerator has not been connected. 	<ul style="list-style-type: none"> • Press Ice Maker.
Ice maker does not make ice.	<ul style="list-style-type: none"> • Ice maker has just been installed. 	<ul style="list-style-type: none"> • You must wait for 12 hours for the refrigerator to make ice.
	<ul style="list-style-type: none"> • Freezer temperature is too high. 	<ul style="list-style-type: none"> • Set the freezer temperature below 0 °F (-18 °C) or -4 °F (-20 °C) in warm ambient air.
	<ul style="list-style-type: none"> • Dispenser panel Lock is activated. 	<ul style="list-style-type: none"> • Deactivate dispenser panel Lock.
	<ul style="list-style-type: none"> • Ice maker is off. 	<ul style="list-style-type: none"> • Turn on the ice maker.



Ice does not dispense	<ul style="list-style-type: none"> • Ice may jam if the ice dispenser is not used for a long time (approx. 3 weeks). 	<ul style="list-style-type: none"> • If you won't be using the refrigerator for a long time, empty the ice bucket and turn off the ice maker.
	<ul style="list-style-type: none"> • Ice bucket is not properly inserted. 	<ul style="list-style-type: none"> • Make sure the ice bucket is properly inserted.
	<ul style="list-style-type: none"> • Water line is not connected properly or water supply is not on. 	<ul style="list-style-type: none"> • Check if the water line is installed correctly. Check if the water line stop cock is closed.
Water does not dispense.	<ul style="list-style-type: none"> • Water line is not connected properly or water supply is not on. 	<ul style="list-style-type: none"> • Check if the water line is installed correctly. Check if the water line stop cock is closed.
	<ul style="list-style-type: none"> • Dispenser panel Lock is activated. 	<ul style="list-style-type: none"> • Deactivate dispenser panel Lock.
	<ul style="list-style-type: none"> • A third-party water filter was installed. 	<ul style="list-style-type: none"> • Use only Samsung-provided or approved filters. • Unapproved filters may leak and damage the refrigerator.
	<ul style="list-style-type: none"> • Water filter indicator turns on or blinks. 	<ul style="list-style-type: none"> • Replace the water filter. After replacing, reset the filter indicator sensor.

SmartThings

Symptom	Action
Could not find "SmartThings" in the app market.	The SmartThings app is designed for Android 6.0 (Marshmallow) or later, iOS 10.0 or later, iPhone 6 or later, and is optimized for Samsung smartphones (Galaxy S and Galaxy Note series).
The SmartThings app fails to operate.	<p>The SmartThings app is available for applicable models only.</p> <p>The old Samsung Smart Refrigerator app cannot connect with Samsung Smart Home models.</p>
The SmartThings app is installed but is not connected to my refrigerator.	<p>You must log into your Samsung account to use the app.</p> <p>Make sure that your router is operating normally.</p> <p>If you have not connected your refrigerator to the SmartThings App after the app was installed, you must make the connection using the device registration function of the app.</p>
Could not log into the app.	<p>You must log into your Samsung account to use the app.</p> <p>If you don't have a Samsung account, follow the app's onscreen instructions to create one.</p>
An error message appears when I try to register my refrigerator.	Easy Connection may fail due to the distance from your access point (AP) or electrical interference from the surrounding environment. Wait a moment and try again.
The SmartThings app is successfully connected to my refrigerator but does not run.	<p>Exit and restart the SmartThings app or disconnect and reconnect the router.</p> <p>Unplug the power cord of the refrigerator, and then plug it in again after 1 minute.</p>

Samsung Family Hub

Symptom	Action
Could not find "Samsung Family Hub" in the app market.	The Samsung Family Hub app is available for smartphones that run Android 4.4 (KitKat) or higher, or iOS 8.0 or higher.
Could not log into the app.	You must log into your Samsung account to use the app. If you don't have a Samsung account, follow the app's onscreen instructions to create one.

LCD

Symptom	Action
Cannot connect to my TV.	This refrigerator can connect only with Samsung Smart TV. Launched in 2015-17: J/K/MU6400 series or above. Launched in 2018: NU7400 series or above. Launched in 2018: Q60R series or above. Please check the model name of your TV first. Network connections may suffer temporary interruptions. Turn your TV off, and then try again.
The inner view picture looks bulged out or incomplete.	The edges of the inner view may look bulged out. The bulging is caused by the convex lens of the camera. The inner view may be incomplete due to the blind spots on the left and right corners or screened depending on the layout of food items. Make sure to place food items in the front center.
The displayed measurement on the Fridge Manager is not correct.	The displayed conditions may differ from the actual temperature and humidity.

Do you hear abnormal sounds from the refrigerator?

Before calling for service, review the information below. If you still have questions about sounds your refrigerator is making, please call Samsung Customer Care at 1-800-SAMSUNG (726-7864). Note that you will be charged for any service visits related to normal operating sounds in which no defects were found.

These sounds are normal.

- When starting or ending an operation, the refrigerator may make sounds similar to a car engine ignition. As the operation stabilizes, the sounds will decrease.
- While the fan is operating, these sounds may occur. When the refrigerator reaches the set temperature, the fan sound will stop.

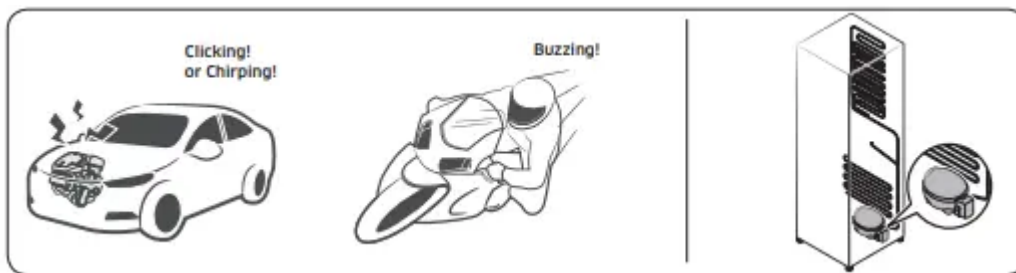

- During a defrost cycle, water may drip on the defrost heater, causing sizzling sounds.



- As the refrigerator cools or freezes, refrigerant gas moves through sealed pipes, causing bubbling sounds.



- As the refrigerator temperature increases or decreases, plastic parts contract and expand, creating knocking noises. These noises occur during the defrosting cycle or when electronic parts are working.

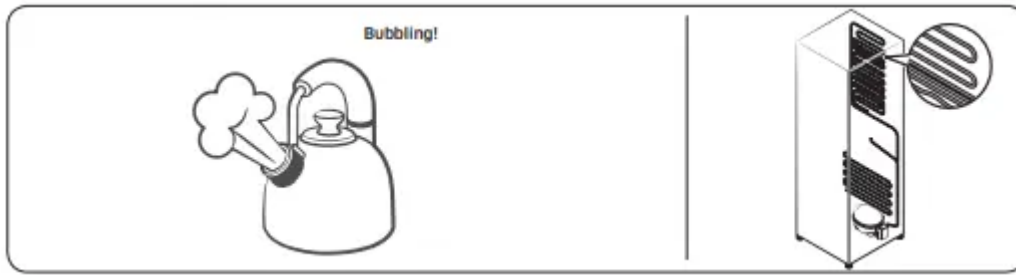

- For ice maker models: When the water valve opens to fill the ice maker, you may hear a buzzing sound.
- Due to pressure equalizing when you open and close the refrigerator door, you may hear a whooshing sound.

Warning

This content is compiled from multiple sources and is provided for reference purposes only. It may not be complete or fully applicable to all situations. If you are unable to resolve your issue, please contact the product manufacturer or an authorized service provider for official support.