

Introducing your new oven

Overview

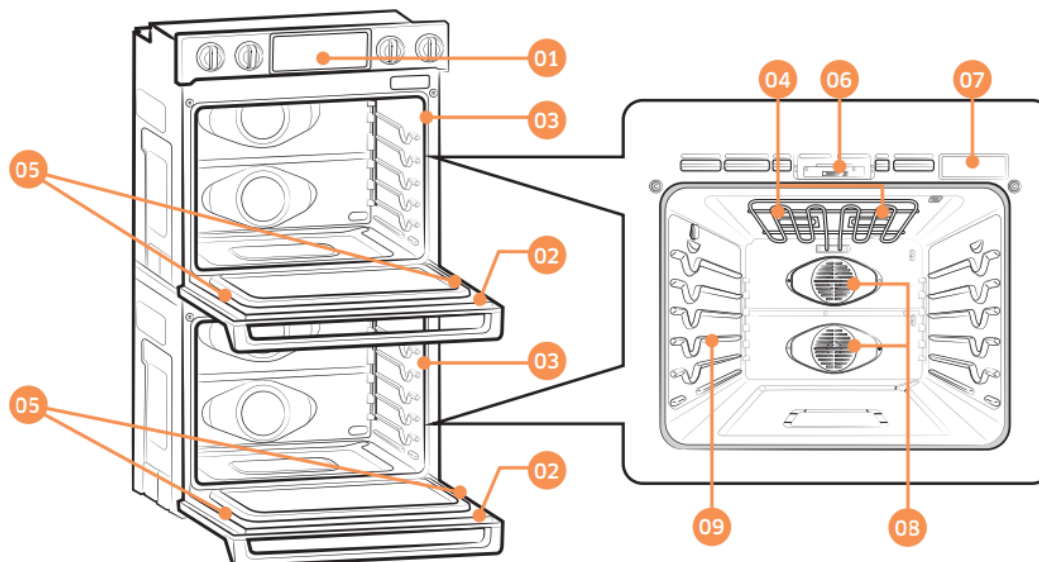

01. Oven control panel

02. Oven door

03. Oven gasket

04. Halogen lamp *

05. Door LED light

06. Door latch

07. Water reservoir

08. Convection fan

09. Shelf position

What's included with your oven

Wire racks (4)*

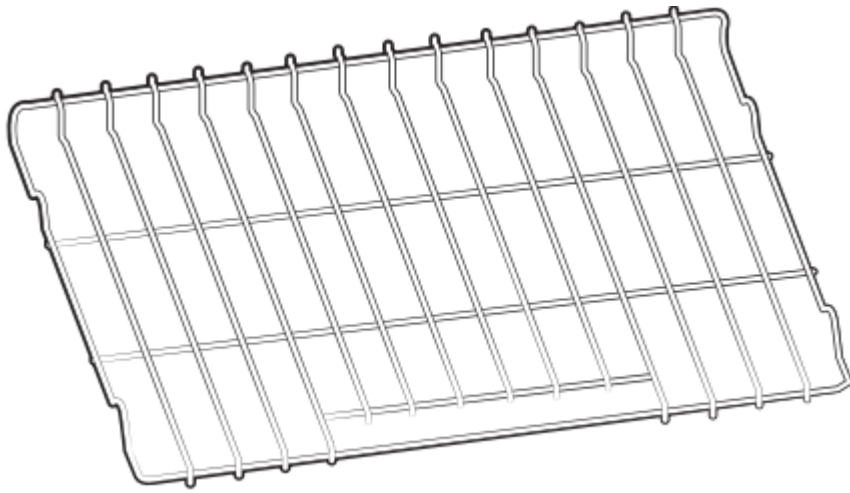

Gliding rack (2)*

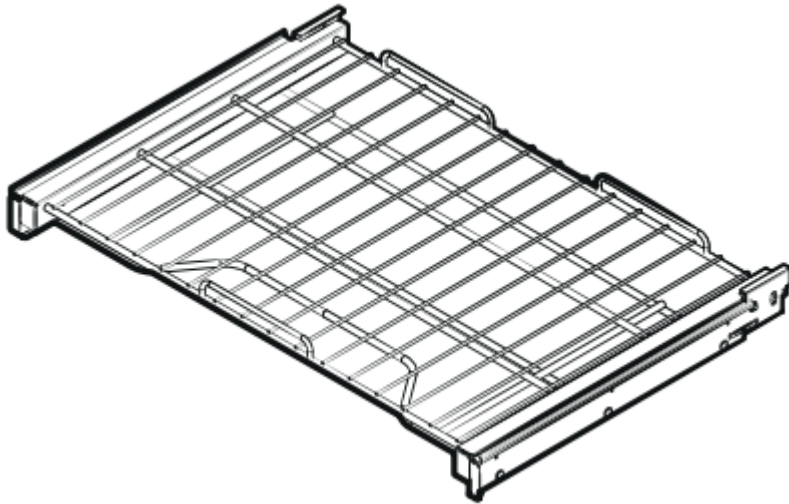

Divider (1)*

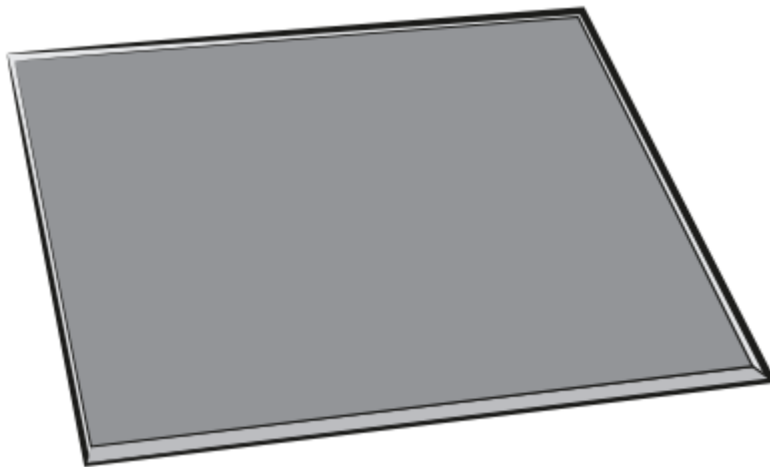

Temp probe (1)*

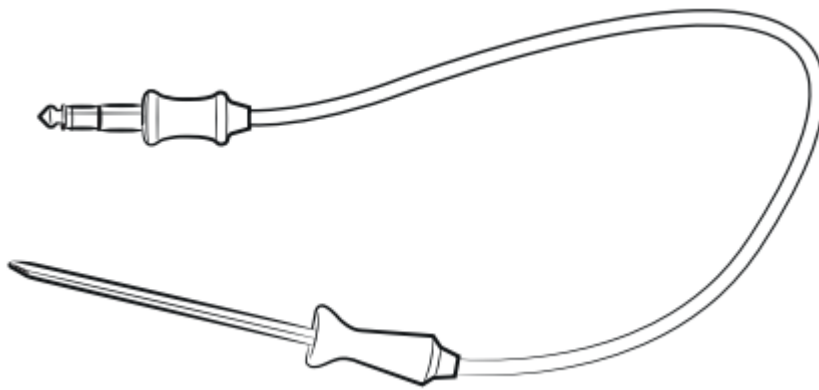



If you need an accessory marked with a *, you can buy it from the Samsung Contact Center (1-800-726-7864).

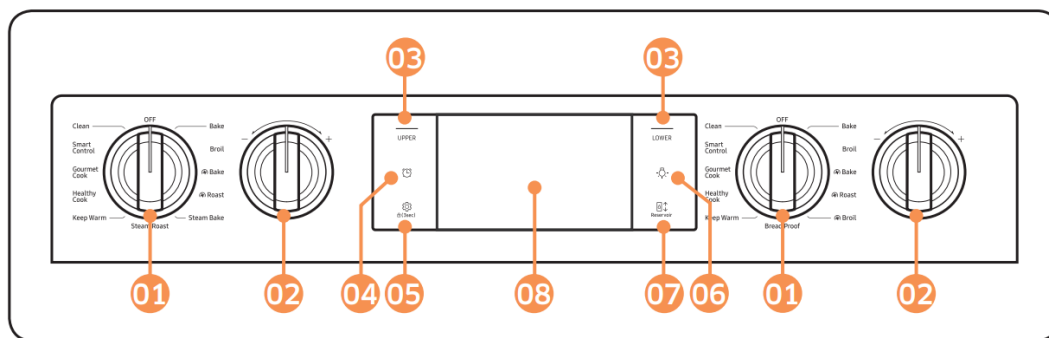

Operating the oven

Control panel



01. Upper or lower mode knob: Use to select the mode of the upper or lower oven.

- Upper: Bake, Broil,  Bake (Convection Bake),  Roast (Convection Roast), Steam Bake, Steam Roast, Keep Warm, Healthy Cook, Gourmet Cook, Smart Control, Clean.

- Lower : Bake, Broil,  Bake (Convection Bake),  Roast (Convection Roast),  Broil (Convection Broil). Bread Proof, Keep Warm, Healthy Cook, Gourmet Cook, Smart Control, Clean.

02. Temperature knob: Use to set the temperature for the upper or lower oven respectively.

03. UPPER, LOWER: Use to display the upper oven or lower oven mode screen on the display. Touching here does not turn the ovens on or off. It only displays their current status.

04. Timer  : Use to display the set Timer screen.

05. Settings and Control Lockout  (3sec) : Use to display the Setting screen. If you touch and hold this key for 3 seconds, all oven functions will be disabled.

06. Lamp  : Use to turn the oven light on or off.



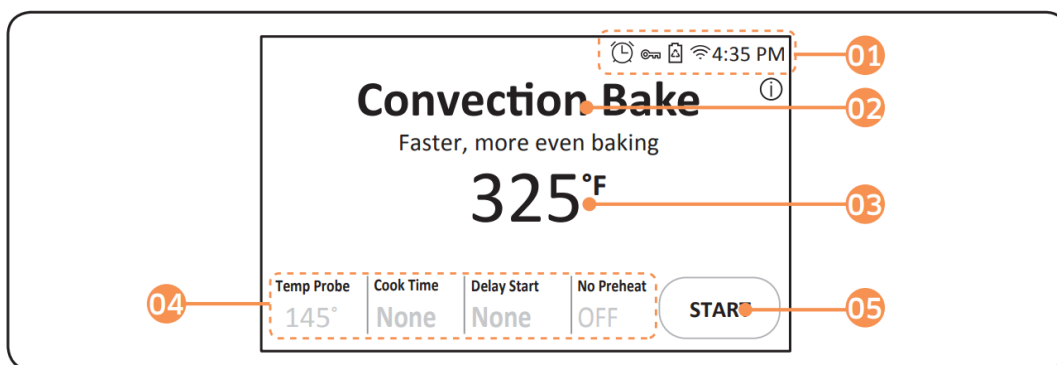

07. Reservoir  : Touch to open the water reservoir.

08. Display: Swipe to navigate through the menus and tap to select a desired setting

Display



01 Indicator area

- Timer  : When the timer is set, the timer indicator is displayed. When more than 2 timers are set, the number of set timers is shown.
- Door lock  : Displayed when the oven door is locked.
- Wi-Fi  : Shows Wi-Fi signal strength in 5 steps.
- 12 hour energy saving  : Displayed when 12 hour energy saving is turned on.
- Current time: The current time is displayed.

02 Mode: The current or selected menu is displayed with a mode description.

03 Temperature: The current or selected temperature is displayed. When you tap this area, the temperature adjustment screen is displayed.

04 Information area

- **Temp Probe:** The set temperature of the temp probe is displayed. When you tap this area, the Temp Probe screen is displayed.
- **Cook Time:** The cooking time is displayed. When you tap this area, the cooking time screen is displayed.
- **Delay Start:** The delay start time is displayed. When you tap this area, the Delay Start screen is displayed.
- **No preheat:** Indicates if the No Preheat feature is on or off. (Only displayed when you are using the Convection Bake or Convection Roast mode.)
- **Steam:** The steam level is displayed. When you tap this area, the steam level screen is displayed. (Only displayed when you are using the Steam Bake or Steam Roast mode.)

05 START: Tap to start the oven using the displayed settings.

Setting the temperature

Temperature knob

- Use the Temperature knob on the left or right side of the control panel to set the temperature for the upper or lower oven respectively.
- Turn the appropriate knob clockwise (+) or counterclockwise (-) and then release. The temperature will rise or fall by 5 °F.
- To change the temperature quickly by more than 5 °F, turn and hold the knob at the + or - position.

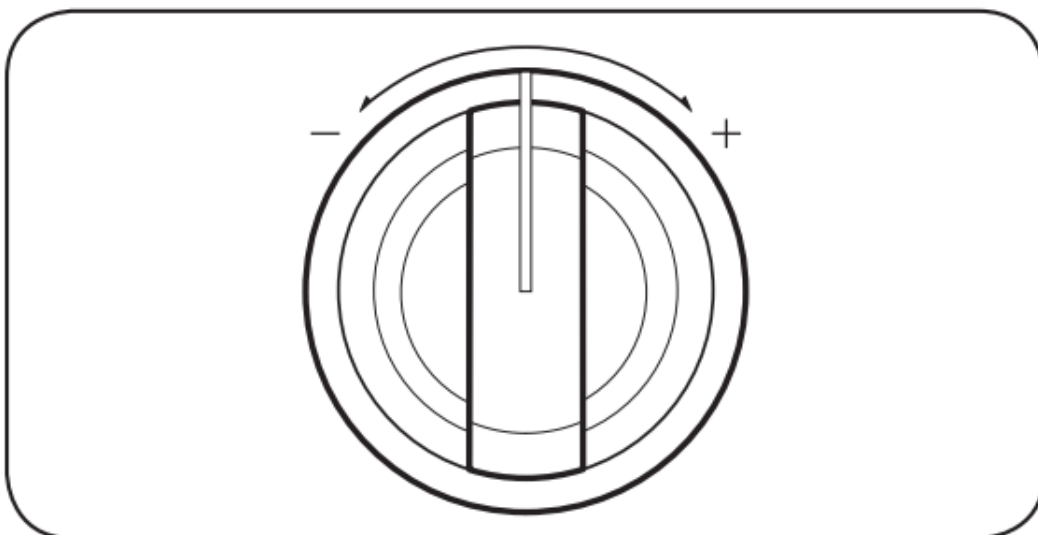

Numeric pad

- Tap the temperature area to display the numeric pad.
- Tap the numbers in the numeric pad to set the temperature.

- Tap OK

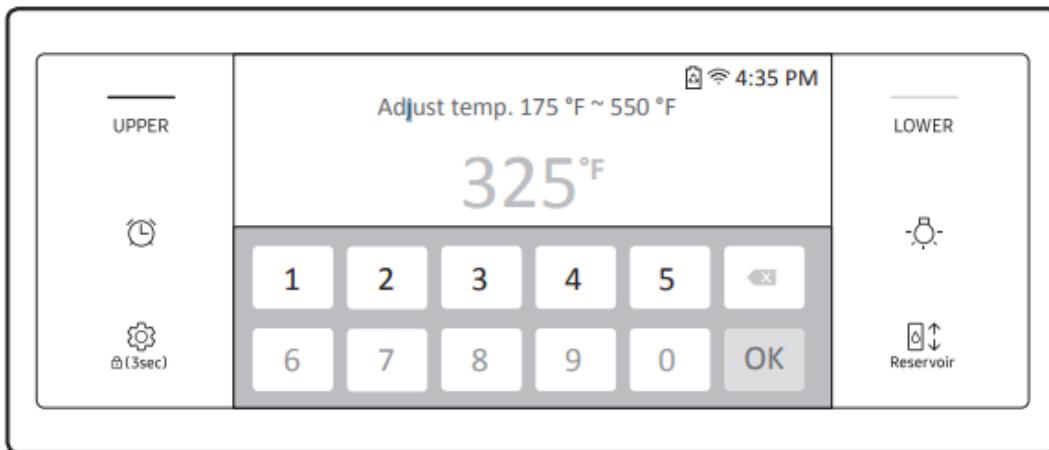
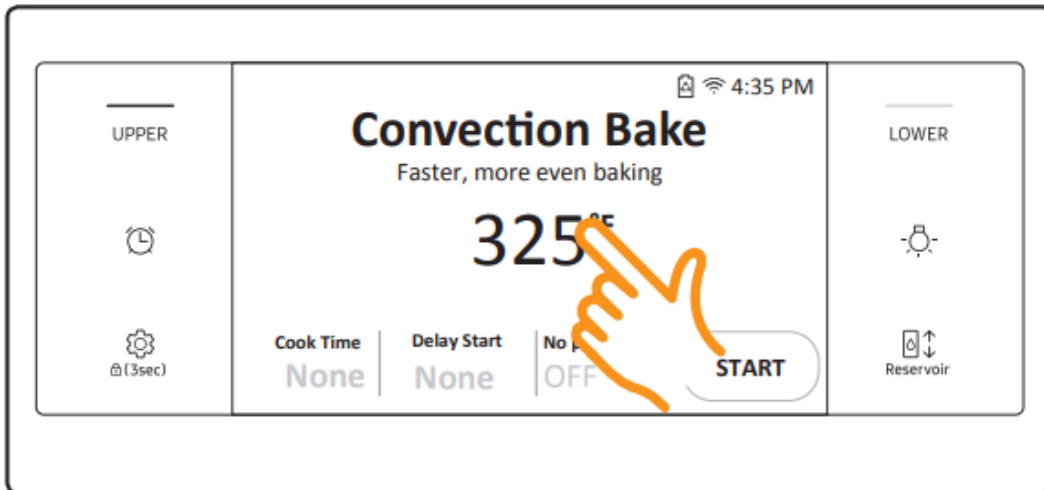

Wheel picker

- Tap and hold the temperature area. The wheel picker appears.
- Set the temperature you want by flicking the wheel picker on the screen.
- Tap OK.

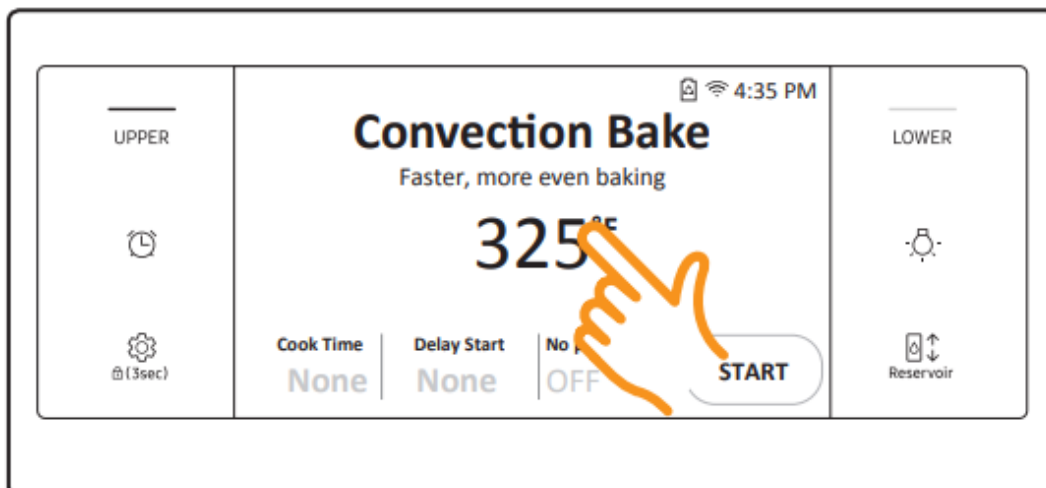

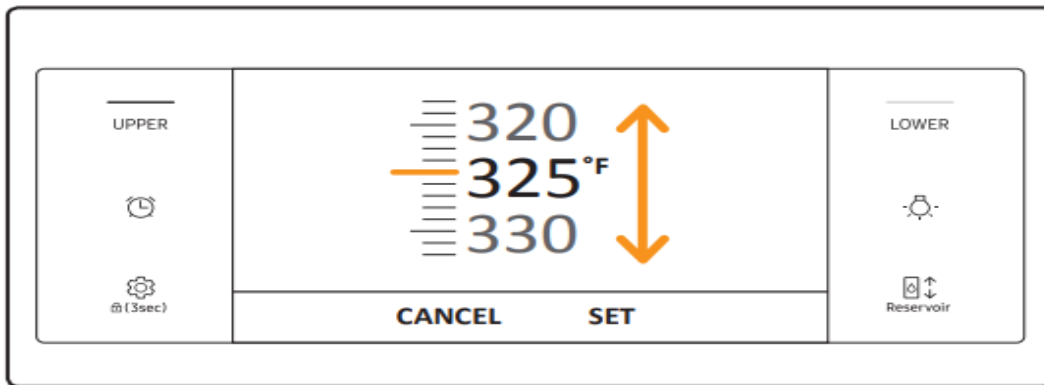



Control Lockout

How to activate the Control Lockout feature

1. Cancel or turn off all functions.

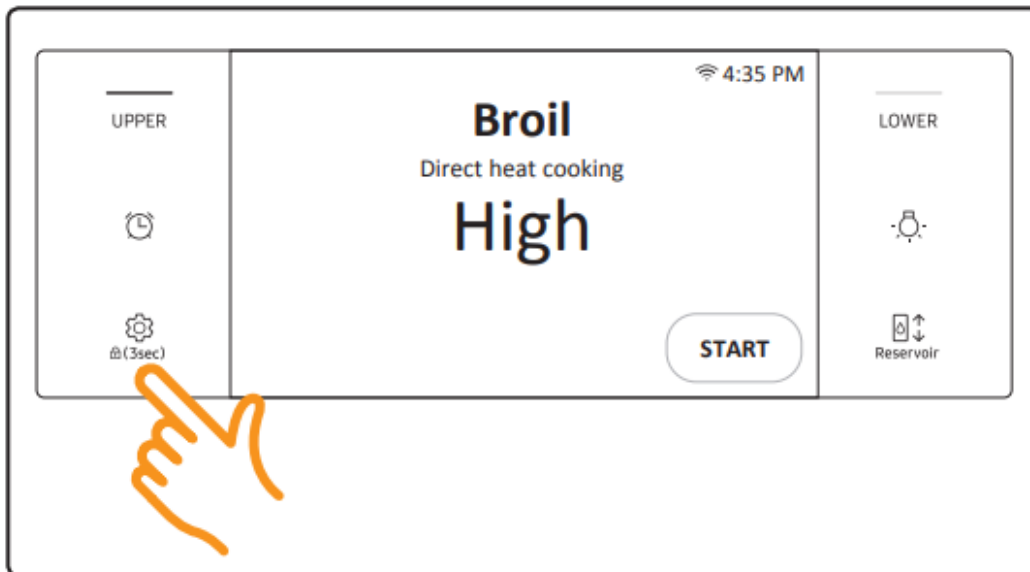

2. Touch Control Lockout   (3sec) for 3 seconds

3. The display will change to the control lock screen and the control lock confirmation will appear at the bottom of the screen.

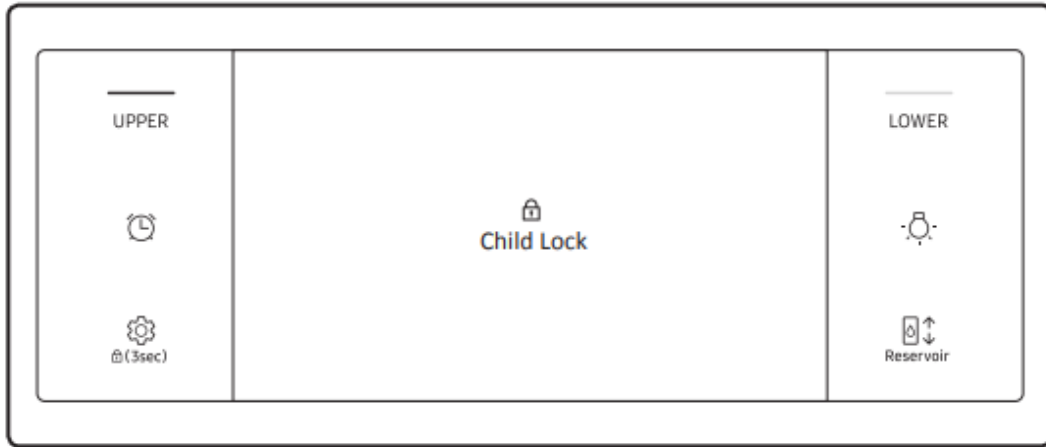



How to unlock the controls

1. Touch Control Lockout   for 3 seconds. The control lock confirmation and the lock icon will disappear from the display.

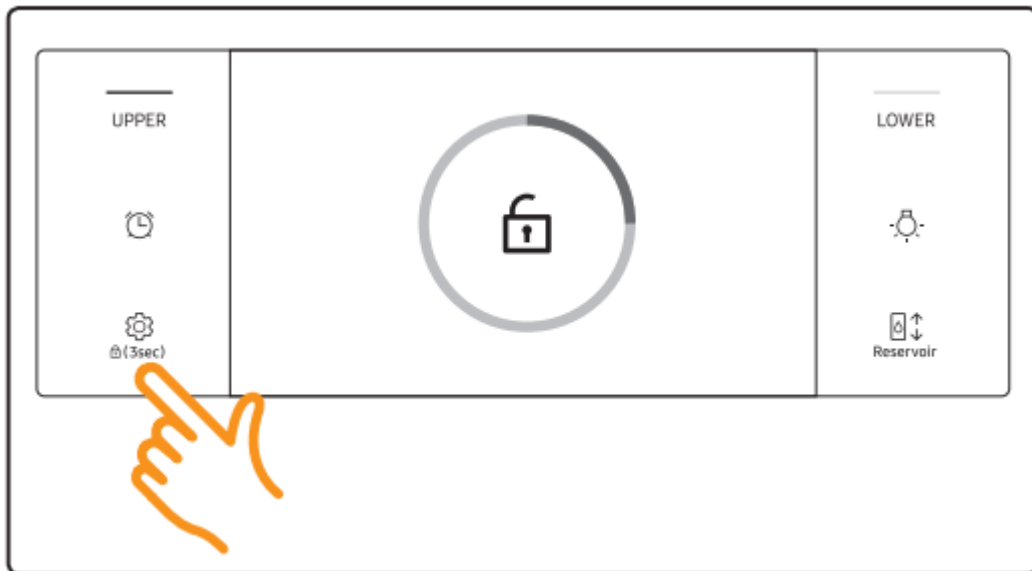

Kitchen Timer

How to set the timer

1. Touch Timer .

The display will be change to the timer screen.

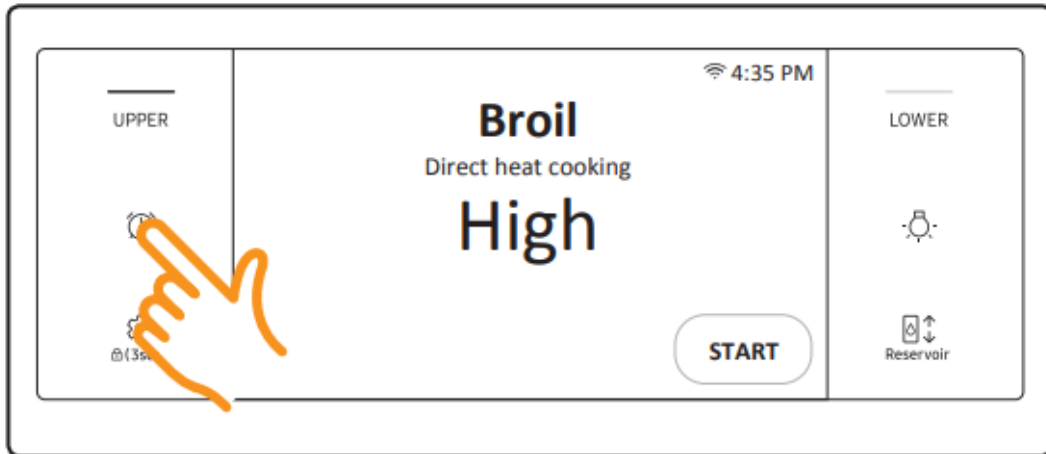

2. Tap + Add timer.

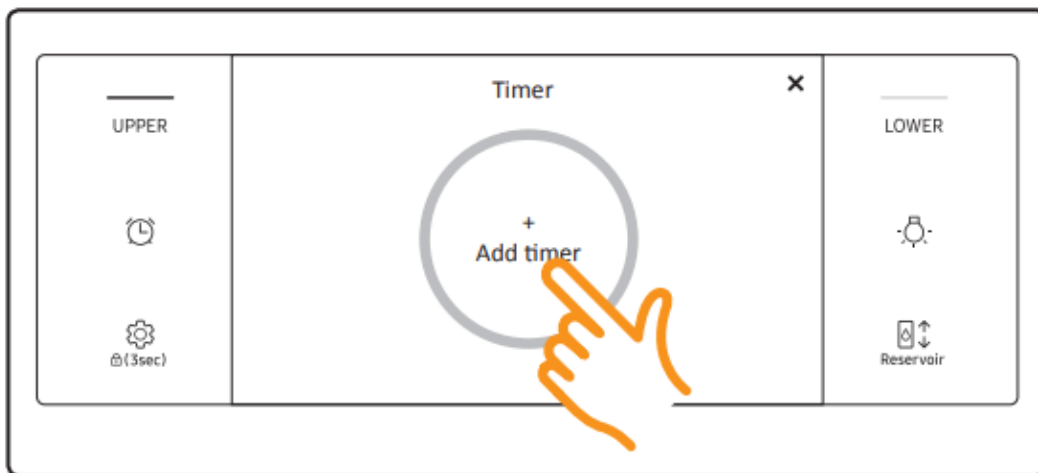

3. Flick screen or tap the time area to set time. (You can set the timer for any amount of time from 1 sec to 24 hr).

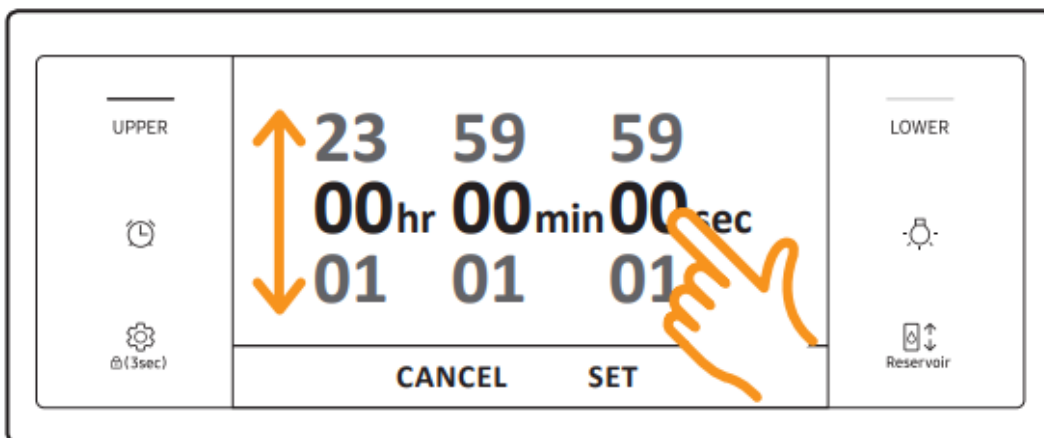

4. Tap SET. The timer is displayed on the screen



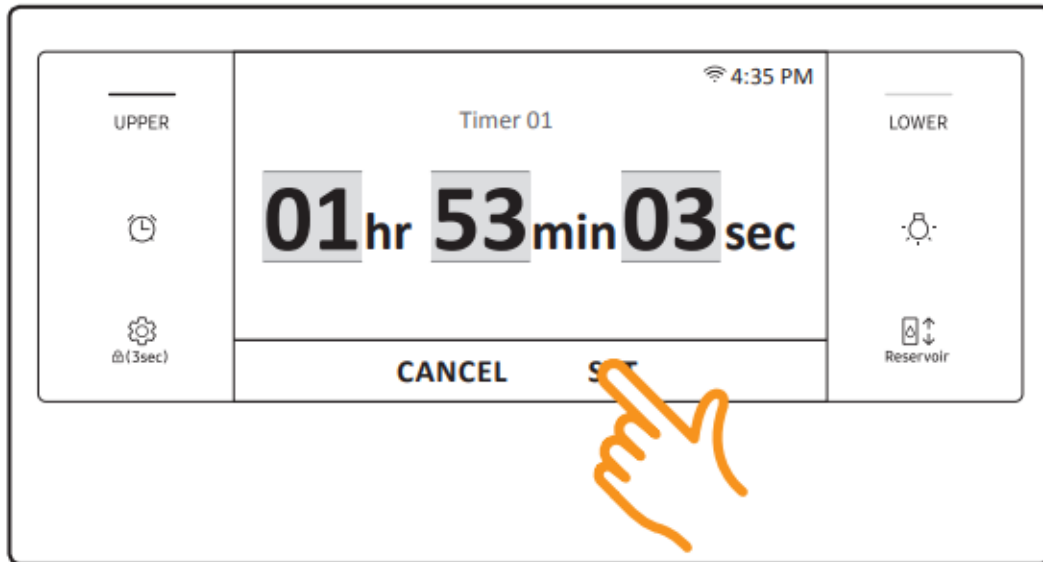

5. Tap START. When the set time has elapsed, the oven will beep and the display will show the Timer has finished.

You can pause, reset, or delete the timer at any time by touching the screen.

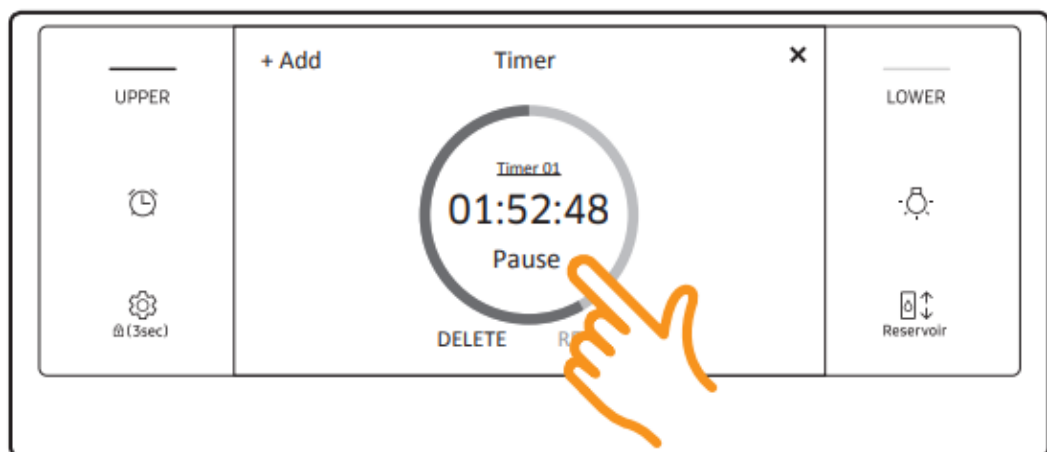
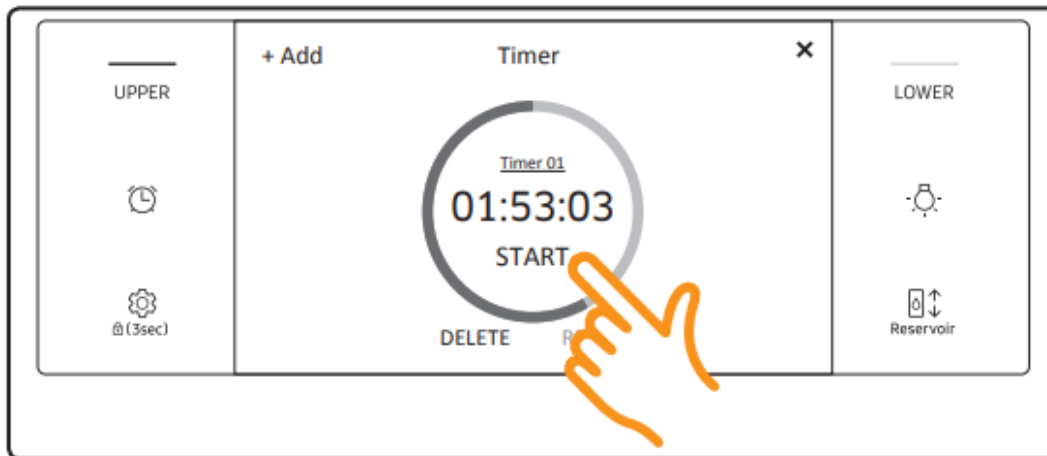

How to change timer name

You can change the timer name to identify what you are timing, for example, a chicken defrosting.

1. Tap the timer name area.

- The keyboard appears.

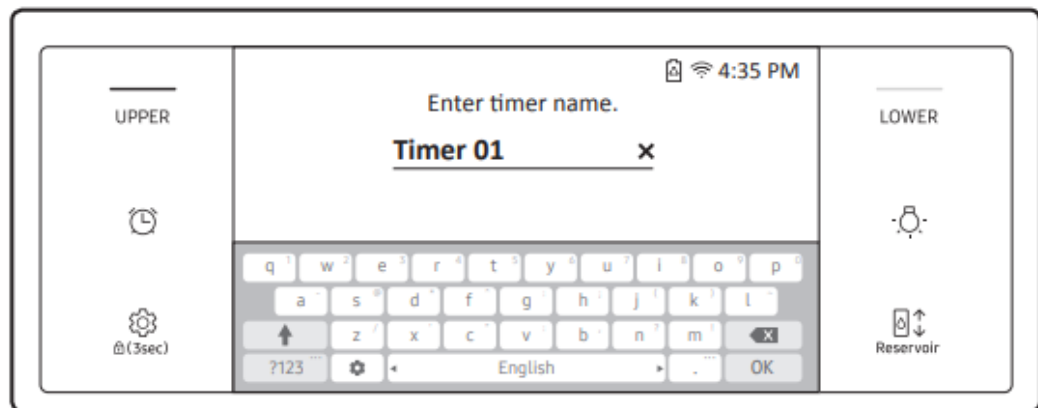
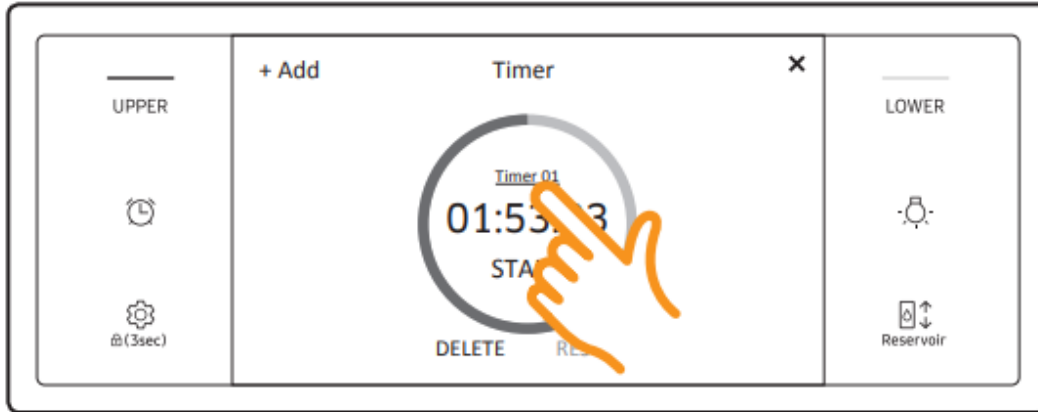

2. Enter the new timer name, and then tap SET

- The display shows the changed timer name.

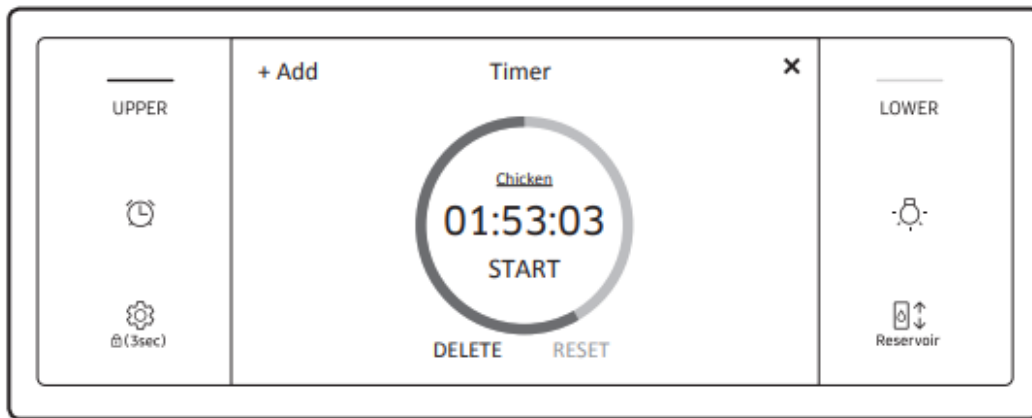
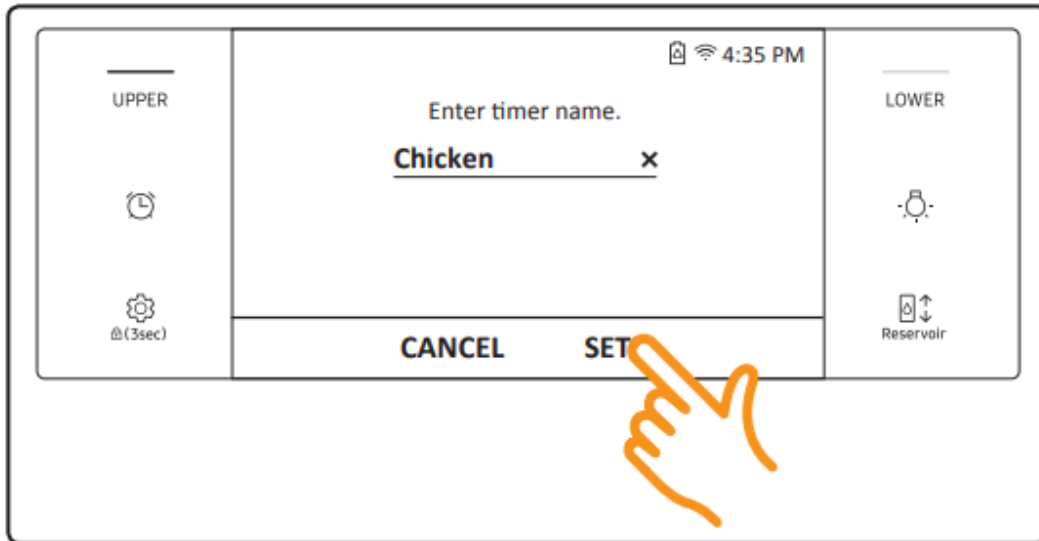

Timed cooking

How to set the oven for timed cooking

1. Turn the upper or lower Oven Mode knob to the cooking operation you want.

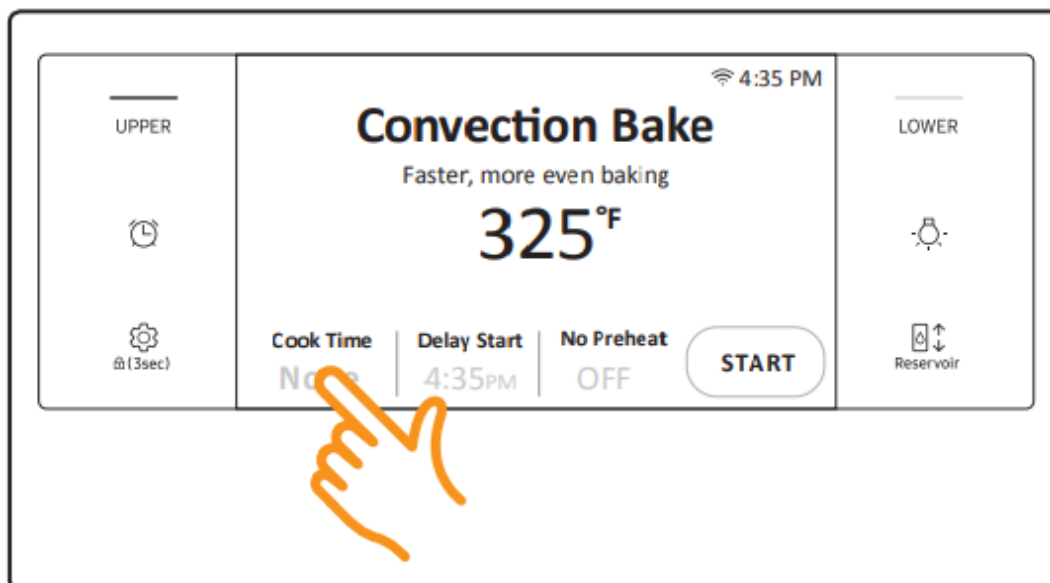

2. Tap Cook Time. The display will change to the cooking time screen.

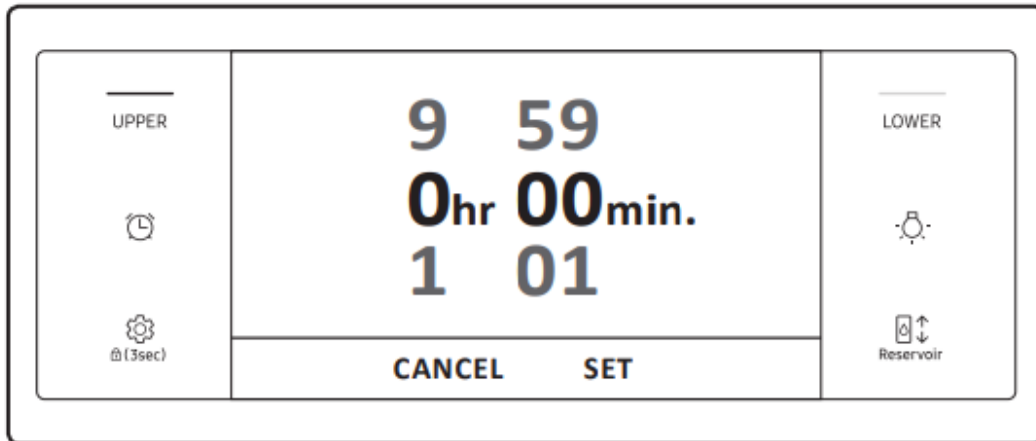

3. Flick the screen or tap the time area to set the cooking time. If you tap the time area, the numeric pad appears. Tap numbers in the numeric pad to set the cooking time. (You can set the cooking time for any amount of time from 1 minute to 9 hours and 59 minutes).

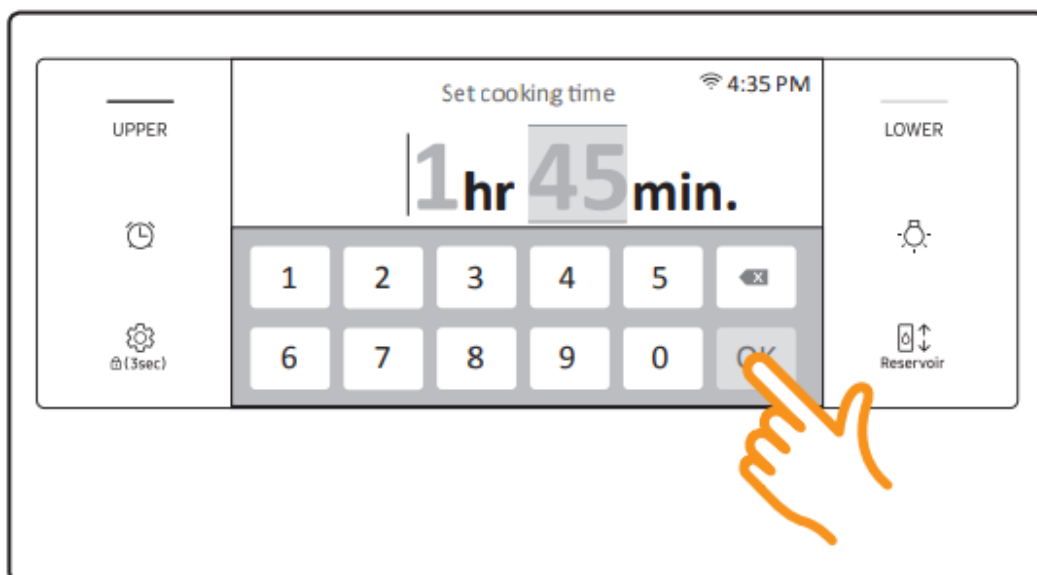

4. Tap SET. The cooking time screen closes. The cooking time is displayed in the Cook Time area on the screen.

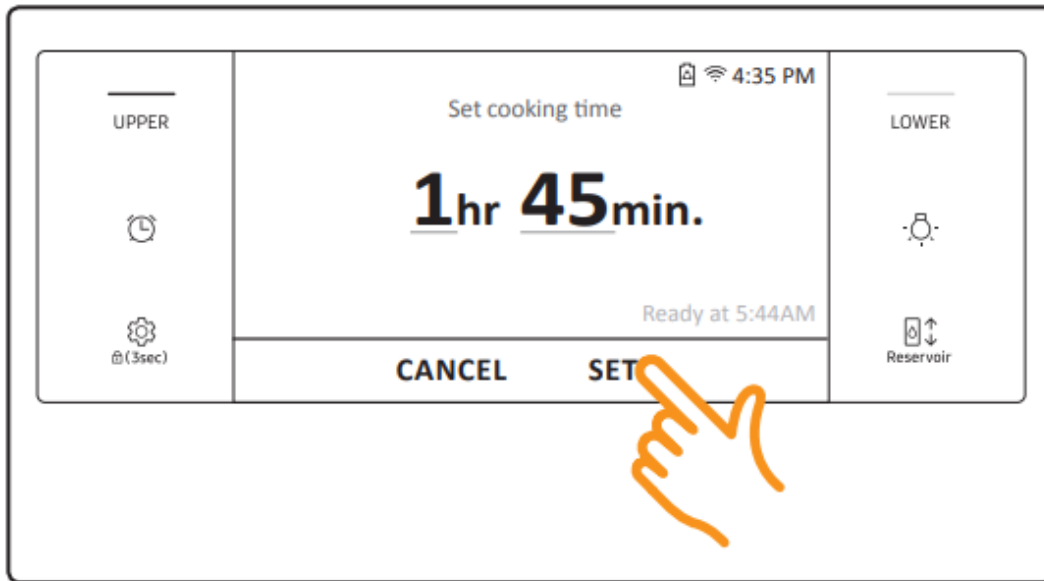

5. You can cancel a cook time at any time by setting the Cook Time to 0 minutes.

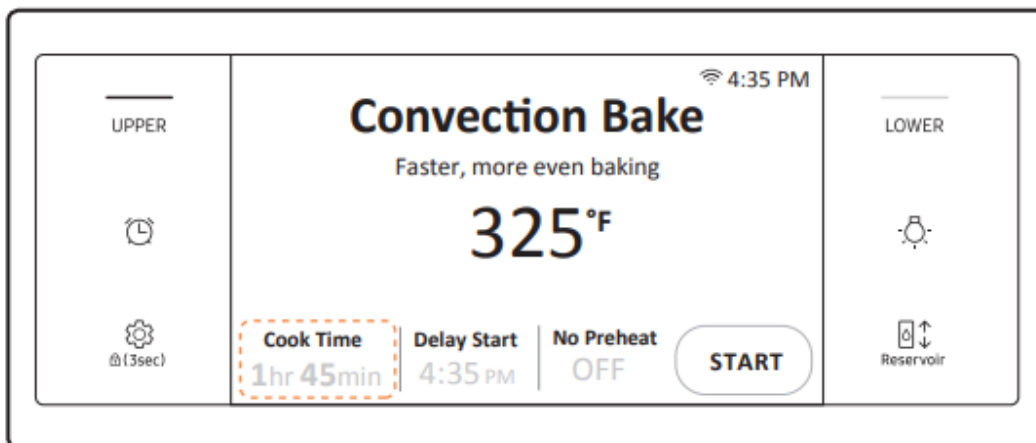

NOTE : See pages 31 through 33 for basic baking and broiling instructions.

Delay Start

How to set the oven for delay timed cooking

1. Position the oven rack(s) and place the food in the oven.
2. Turn the upper or lower Oven Mode knob to the cooking operation you want.
3. Set the cooking time if you want the oven to turn off automatically after a set time. (See the Timed cooking section on page 24).

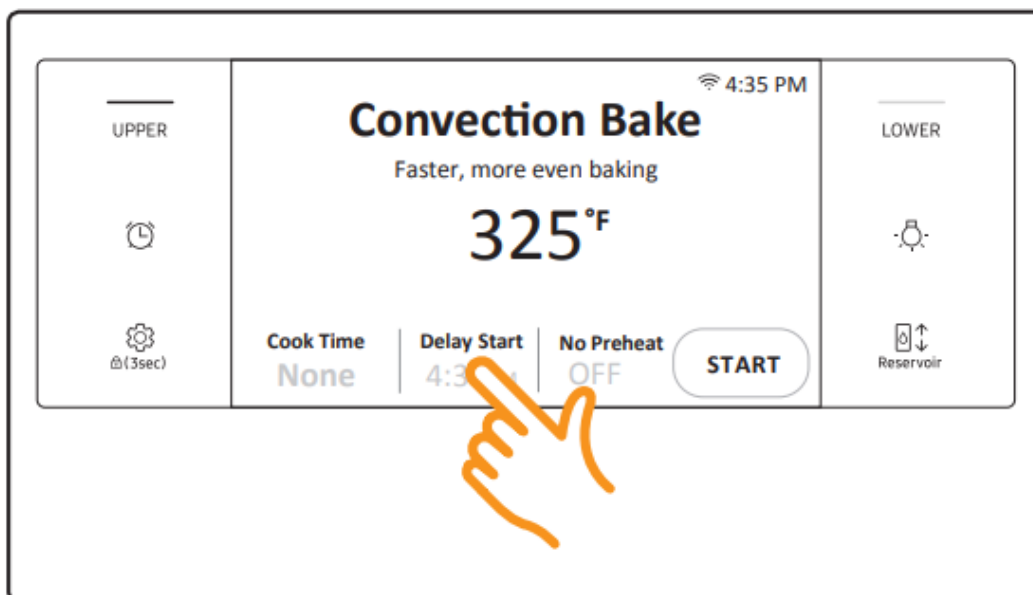

4. Tap Delay Start. The current time is displayed as the first entry
5. Flick the screen or tap the time area to set the start time. If you tap the time area, the numeric pad appears. Tap numbers in the numeric pad to set the time you want the oven to start.
6. Tap SET. The Delay Start screen closes. The start time, and, if you set it, the cooking time, is displayed on the screen.

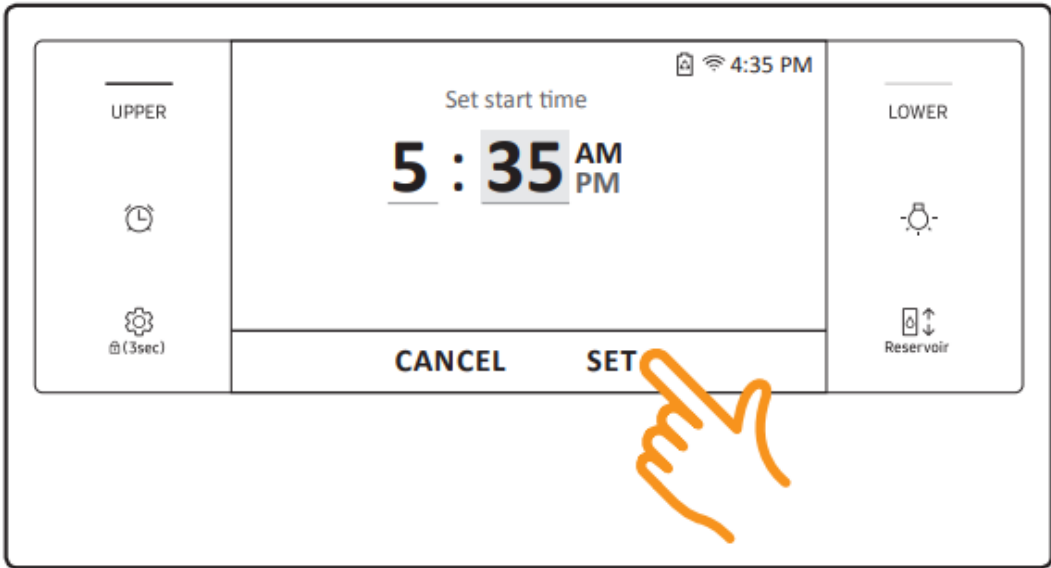
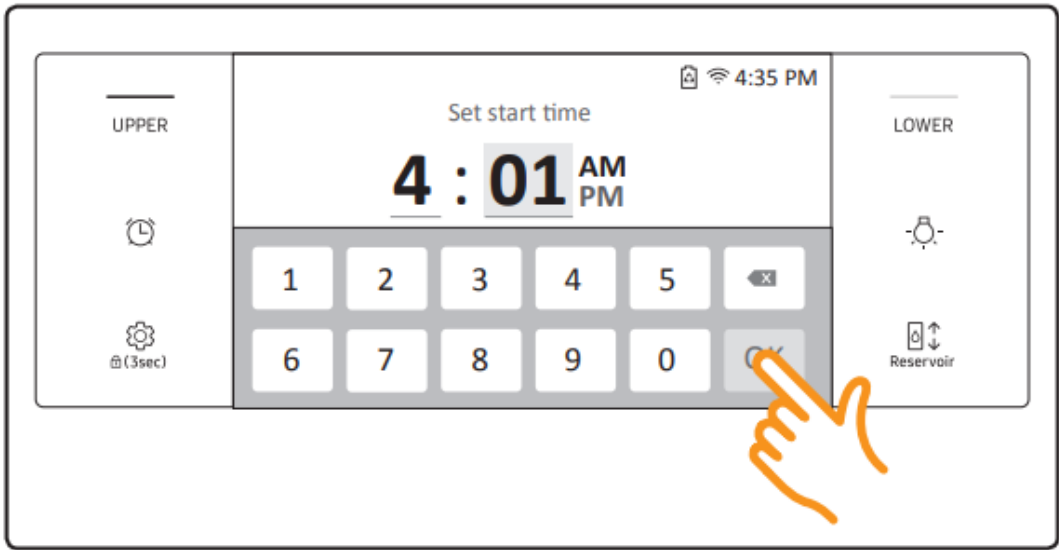
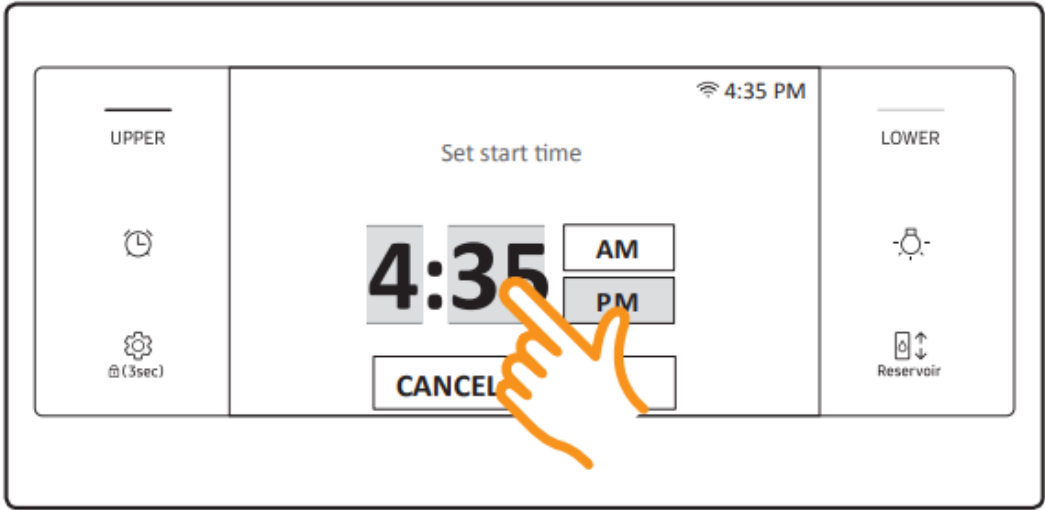

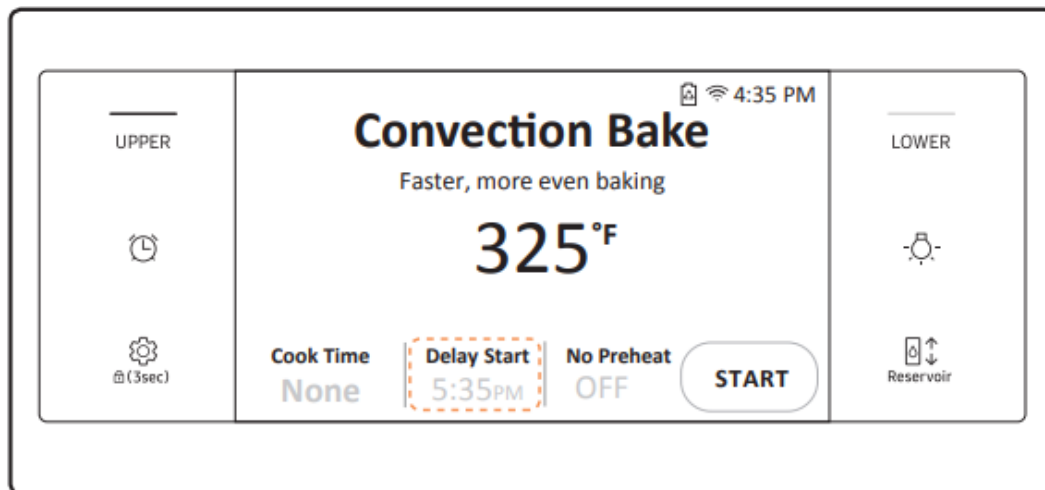

Using the Temp probe

How to use the Temp probe

1. Push the tip of the Temp probe into the meat as fully as possible, so that the tip is in the center of the meat.
 - Insert the probe completely into the meat as shown in the illustrations. It should not touch bone, fat, or gristle.
 - If you do not fully insert the probe into the meat, the Temp Probe function will not work correctly because the probe will sense the oven temperature, not the temperature of the meat.
 - For bone-in meats, insert the probe into the center of the lowest and thickest portion of the piece.
 - For whole poultry (turkey, large chickens, etc.), insert the probe into the thickest part of the inner thigh, parallel to the leg.
 - If you activate the Keep Warm function to keep the meat warm after you have cooked it using the Temp Probe function, the meat's internal temperature will exceed the temperature you want.

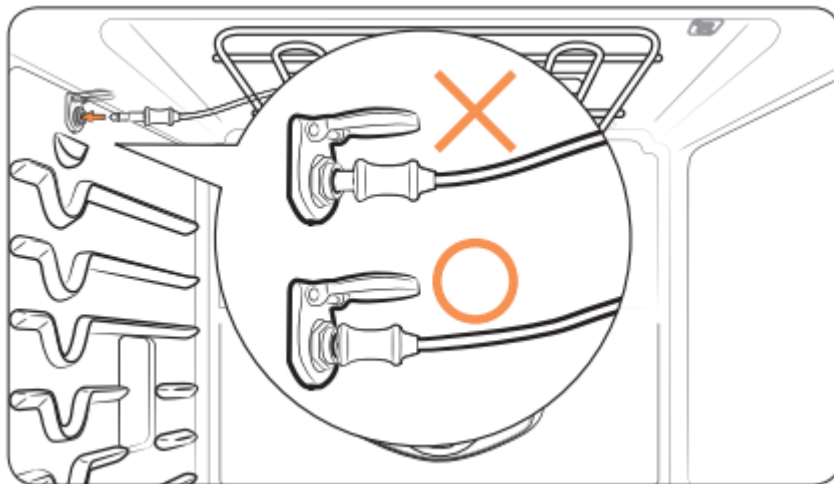
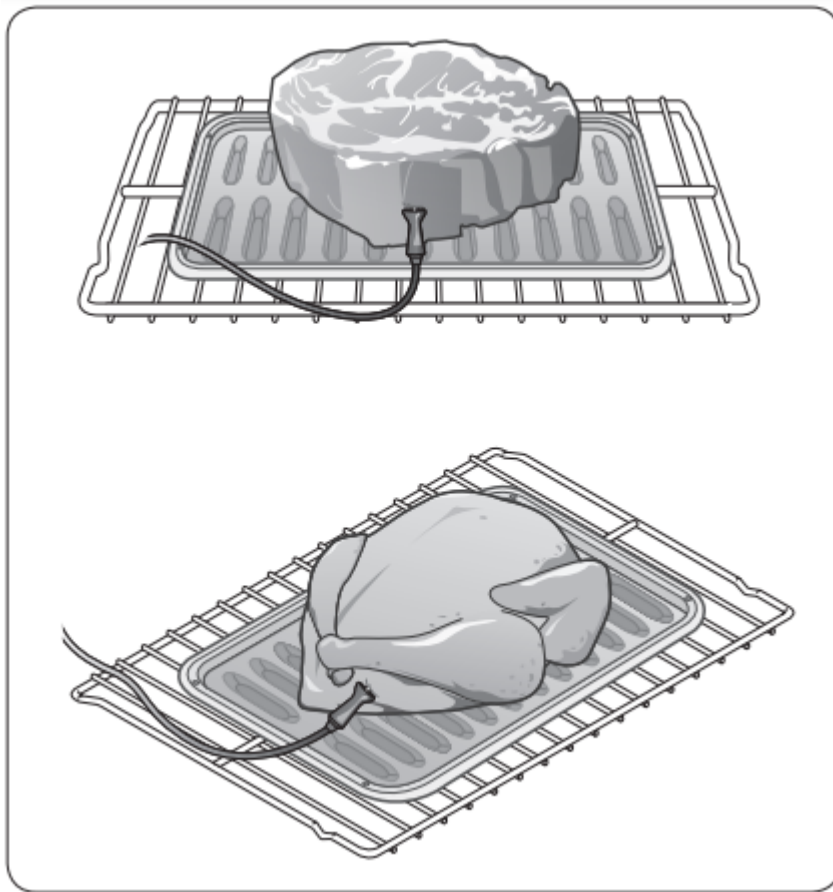

2. Insert the temp probe plug into the socket on the top side wall of the oven as far as it will go.
3. Turn the upper or lower oven Mode knob to select the desired cooking mode (Bake, Convection Bake or Convection Roast). Set the cooking temperature. (See pages 21 and 31.)
4. Tap Temp Probe to set the desired internal temperature.
5. Set the desired internal temperature using the numeric pad.

Available temperatures	100 °F to 200 °F
------------------------	------------------

6. If you want to use the Cook time or Delay start, set each function.
7. Tap START.
8. When the desired internal temperature is reached, the function automatically stops and an alarm sounds.



Temp probe table

Type of Food		Internal temperature
Beef / Lamb	Rare	140 °F
	Medium	160 °F
	Well done	170 °F
Pork		170 °F
Poultry		180-185 °F

Removing the Temp probe

Remove the temp probe plug from the socket.

Oven functions

Oven			Oven functions
 Without a divider	Single oven	Upper	Bake, Broil, Convection Bake, Convection Roast, Steam Bake, Steam Roast, Keep Warm, Healthy Cook, Gourmet Cook, Smart Control, Clean
		Lower	Bake, Broil, Convection Bake, Convection Roast, Convection Broil, Bread Proof, Keep Warm, Healthy Cook, Gourmet Cook, Smart Control, Clean
 With a divider	*Twin oven	Upper	Broil, Convection Bake, Convection Roast, Steam Bake, Healthy Cook, Smart Control
		Lower	Bake, Convection Bake, Healthy Cook, Smart Control

* To use the twin flex oven functionality, you must insert the divider into the upper oven and divide it into an upper and lower compartment. See page 40.

Cooking mode

Turn the Upper or Lower oven mode knob to select the cooking mode. Set the temperature using the Upper or Lower oven Temp knob, the numeric pad, or the wheel picker. See Setting the Temperature on pages 21 and 22 and Basic Baking and Broiling Instructions starting on page 31.

Mode	Temperature range		Single oven		*Twin oven		Temp probe	No preheat
	Single oven	*Twin oven	Upper	Lower	Upper	Lower		
Bake	175 °F (80 °C) - 550 °F (285 °C)	175 °F (80 °C) - 480 °F (250 °C)	0	0	-	0	0	-
Broil	LO / HI	LO / HI	0	0	0	-	-	-
Convection Bake	175 °F (80 °C) - 550 °F (285 °C)	175 °F (80 °C) - 480 °F (250 °C)	0	0	0	0	0	0
Convection Roast	175 °F (80 °C) - 550 °F (285 °C)	175 °F (80 °C) - 480 °F (250 °C)	0	0	0	-	0	0
Steam Bake	230 °F (110 °C) - 550 °F (285 °C)	230 °F (110 °C) - 480 °F (250 °C)	0	-	0	-	-	-
Steam Roast	230 °F (110 °C) - 550 °F (285 °C)	230 °F (110 °C) - 480 °F (250 °C)	0	-	-	-	-	-
Conv.broil	175 °F (80 °C) - 550 °F (285 °C)	-	-	0	-	-	-	-
Bread Proof	**None	-	0	0	-	-	-	-
Keep Warm	**None	-	0	0	-	-	-	-

* To use the twin flex oven functionality, you must insert the divider into the upper oven and divide it into an upper and lower compartment. See page 40.

** None means that a factory set temperature is applied for the best performance. You cannot adjust this temperature.

Mode	Instruction
Bake	<ul style="list-style-type: none"> • Bake is used to cook cakes, cookies, and casseroles. Always preheat the oven first. • Baking temperatures and times will vary depending on the ingredients and the size and shape of the baking pan used. • Dark or nonstick coatings may cook faster with more browning
Broil	<ul style="list-style-type: none"> • Broiling is a method of cooking tender cuts of meat by direct heat under the broil element of the oven. • The high heat cooks quickly and gives a rich, brown outer appearance. Broil mode is best for meats, fish, and poultry up to 1 inch thick. • Always preheat the oven for 5 minutes before broiling. • See the Broiling recommendation guide section starting on page 30.
Convection Bake	<ul style="list-style-type: none"> • Convection Bake uses a fan to circulate the oven's heat evenly and continuously within the oven. • This improved heat distribution allows for even cooking and excellent results while using multiple racks at the same time. • Breads and pastries brown more evenly
Convection Roast	<ul style="list-style-type: none"> • Convection Roast is good for cooking large tender cuts of meat, uncovered. The convection fan circulates the heated air evenly over and around the food. • Meat and poultry are browned on all sides as if they were cooked on a rotisserie. • The heated air seals in juices quickly for moist and tender results while, at the same time, creating a rich golden brown exterior
Steam Bake	<ul style="list-style-type: none"> • Steam Bake provides excellent baking conditions for breads, pastries, and desserts by increasing moisture content and improving texture and flavor. • See the Steam cook recommendation guide section starting on page 31.



Steam Roast	<ul style="list-style-type: none"> • Steam Roast provides excellent cooking conditions for roasted meats or poultry by maintaining a crispy surface while sealing in the juices for a moist and tender result. • See the Steam cook recommendation guide section starting on page 31
Convection Broil	<ul style="list-style-type: none"> • Convection Broil is similar to Broil, but with the additional benefit of air circulation by the motorized fan in the rear of the oven. • During Convection Broil mode, the broil element will cycle on and off in intervals to maintain oven temperature, while the fan circulates the hot air. • Use this mode for thicker cuts of meat, fish, and poultry. Convection Broil gently browns the exterior and seals in the juices. • For optimum browning, preheat the broil element for 5 minutes
Bread Proof	<ul style="list-style-type: none"> • Bread Proof provides an optimal temperature for the bread proofing process, and therefore does not require a temperature adjustment. • For the best results, always start the Bread Proof option with a cool oven.
Keep Warm	<ul style="list-style-type: none"> • The keep warm mode will keep cooked food warm for serving up to 3 hours after cooking has finished. • You can use the keep warm mode without any other cooking operations or you can set it to activate after a timed or delay timed cooking operation. • You should not use this mode to reheat cold food.

Broiling recommendation guide

The size, weight, thickness, starting temperature, and your doneness preference will affect broiling times. This guide is based on meats at refrigerator temperature. Always use a broiler pan and its grid when broiling. Always preheat the oven for 5 minutes before broiling.



Food	Doneness	Size	Thickness	Level	Rack position	Cooking time(min)	
						1st side	2nd side
Hamburgers	Medium	9 patties	3/4"	Hi	6	3:00	2:00
	Medium	9 patties	1"	Hi	6	3:20	2:20
Beef steaks	Rare	-	1"	Hi	5	5:00	4:00
	Medium	-	1- 1 1/2"	Hi	5	6:00-6:30	4:30-4:00
	Well done	-	1- 1 1/2"	Lo	4	7:00-8:00	4:00-5:00
Chicken pieces	Well done	4.5 lbs.	1/2-3/4"	Lo	3	16:00-18:00	13:00-15:00
	Well done	2 lbs.	1/2-3/4"	Lo	3 or 4	15:00-16:00	10:00-12:00
Pork chops	Well done	1 lbs.	1"	Lo	3	8:00-10:00	6:00-8:00
Fish fillets	Well done	-	1/4-1/2"	Lo	3 or 4	7:00-8:00	4:00-5:00

Using the smart control feature

To use the oven's Smart Control feature, you must download Samsung's Smart Home app to a mobile device. Functions that can be operated using Samsung's Smart Home app may not work smoothly if communication conditions are poor or the oven is installed in a place with a weak Wi-Fi signal. Please refer to the following table for the main functions that can be operated from the app.

When Smart Control on the oven is off	Monitoring (Oven, Probe), Oven off
When Smart Control on the oven is on.	Monitoring (Oven, Probe), Oven start, Oven off, Error check

How to connect the oven

1. Download and open the Samsung Smart Home app on your smart device.
2. Follow the app's on-screen instructions to connect your oven.
3. Once the process is complete, the connected  icon located on your oven displays and the app will confirm you are connected.
4. If the connection icon does not turn on, follow the instruction in the app to reconnect.

To start the oven remotely

1. Turn the Mode knob to Smart Control. The oven can now be started and controlled remotely by a connected mobile device.

- Remotely change oven settings (mode, time, temperature) using your mobile device.

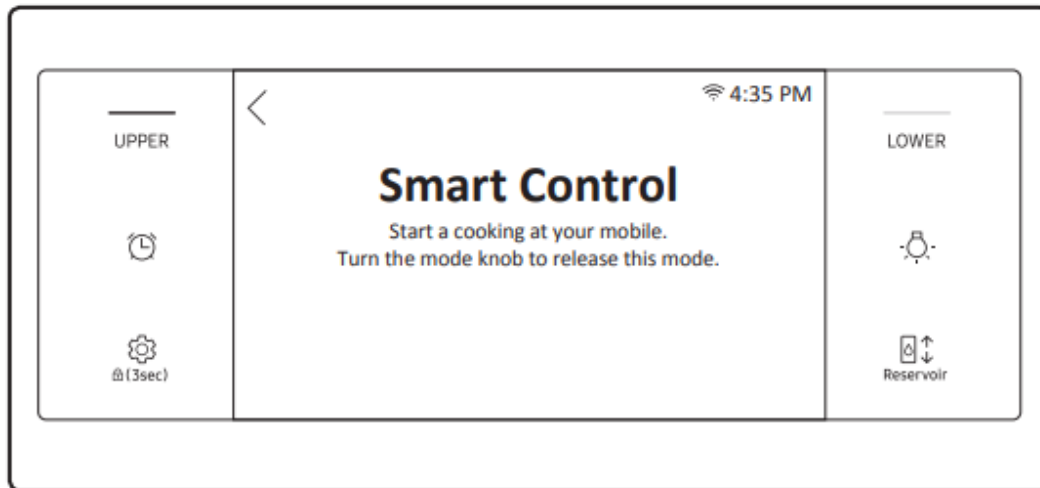

When Smart Control is on you can:

- Remotely start the oven.
- Remotely turn off the oven.
- Once cooking starts, you can change the cooking time and temperature remotely

Using the oven racks

Upper and lower oven rack positions (single mode)

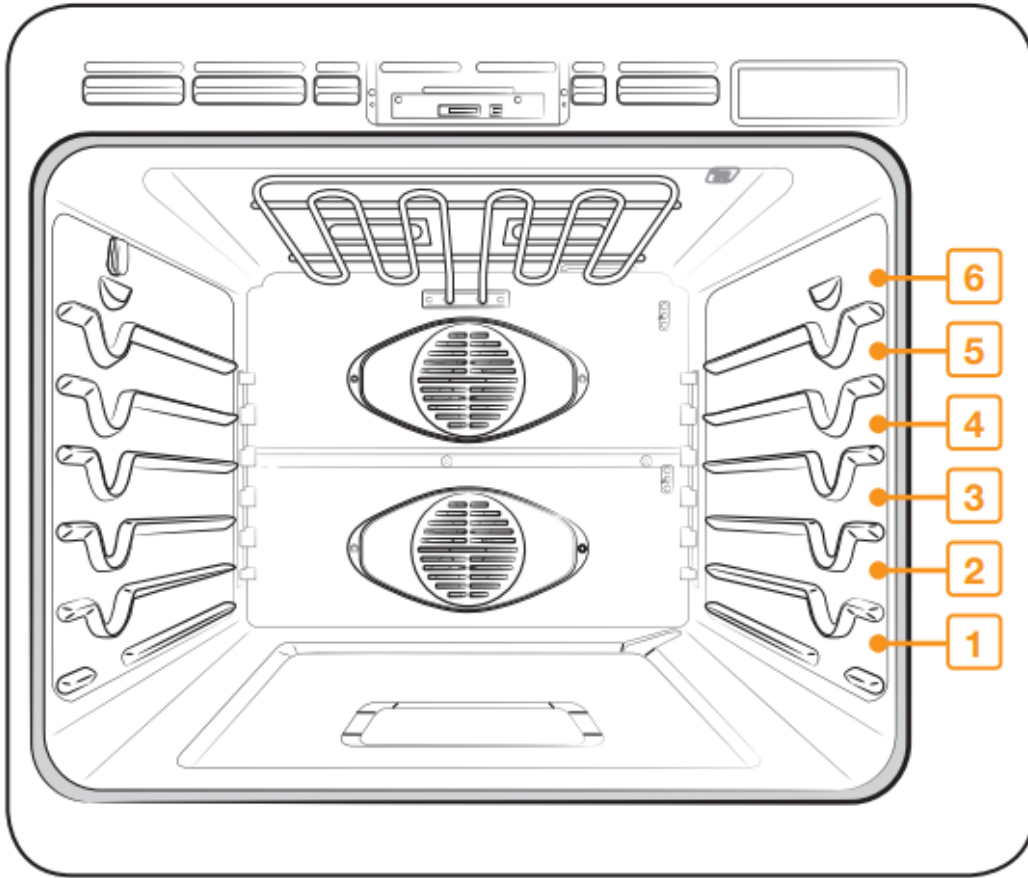

Recommended rack positions for cooking

TYPE OF FOOD	RACK POSITION
Broiling hamburgers	6
Broiling meats or small cuts of poultry, fish	3-5
Bundt cakes, pound cakes, frozen pies, casseroles	4 or 3
Angel food cakes, small roasts	2
Turkeys, large roasts, hams, fresh pizza	1

Upper oven rack positions with divider (twin mode)

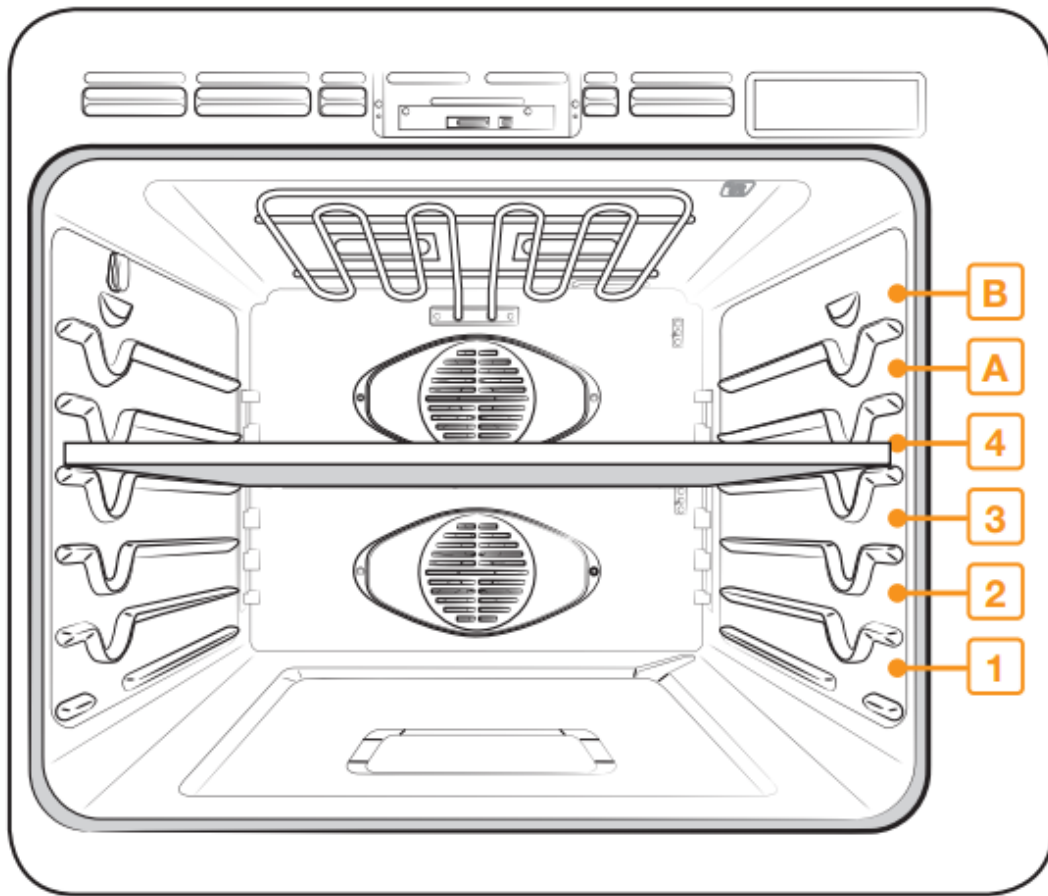

The upper compartment has 2 rack positions (A, B). The lower compartment has 3 rack positions (1-3).

TYPE OF FOOD	RACK POSITION	
	Upper	Lower
Frozen pies	A	1
Angel food cakes	-	1
Bundt or pound cakes	-	1
Muffins, brownies, cookies, cupcakes, layer cakes, Pies, Biscuits	A	1
Casseroles	A	1
Small roast, hams	A	1
Small turkeys, medium roasts	-	1

Rack and Pan placement

Centering baking pans in the oven as much as possible will produce better results. If baking with more than one pan, place the pans so each has at least 1" to 1½" of air space around it. When baking on a single oven rack, place the oven rack in position 3 or 4. See the figure on the left. When baking cakes and cookies on multiple racks, place the oven racks in positions 3 and 5

Single Oven Rack

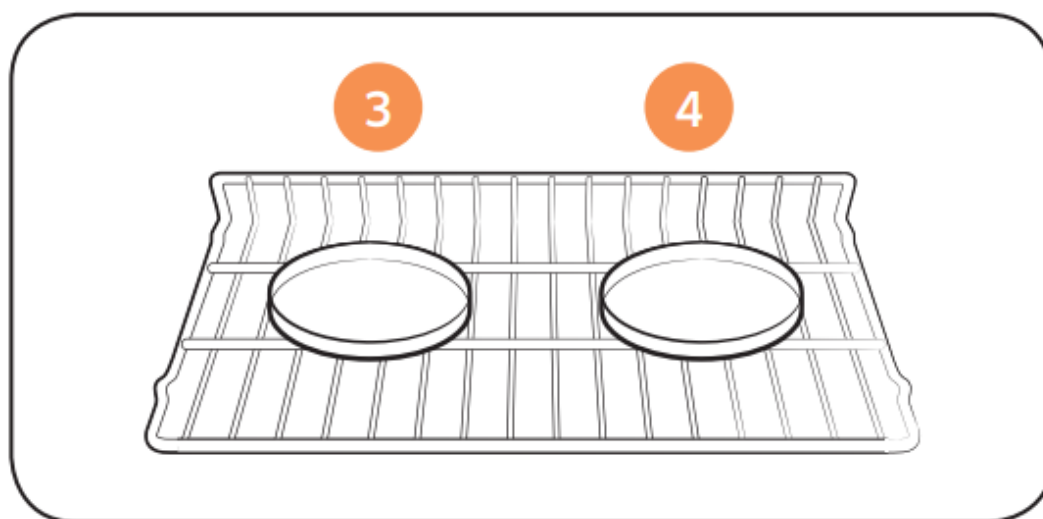

Multiple Oven Racks

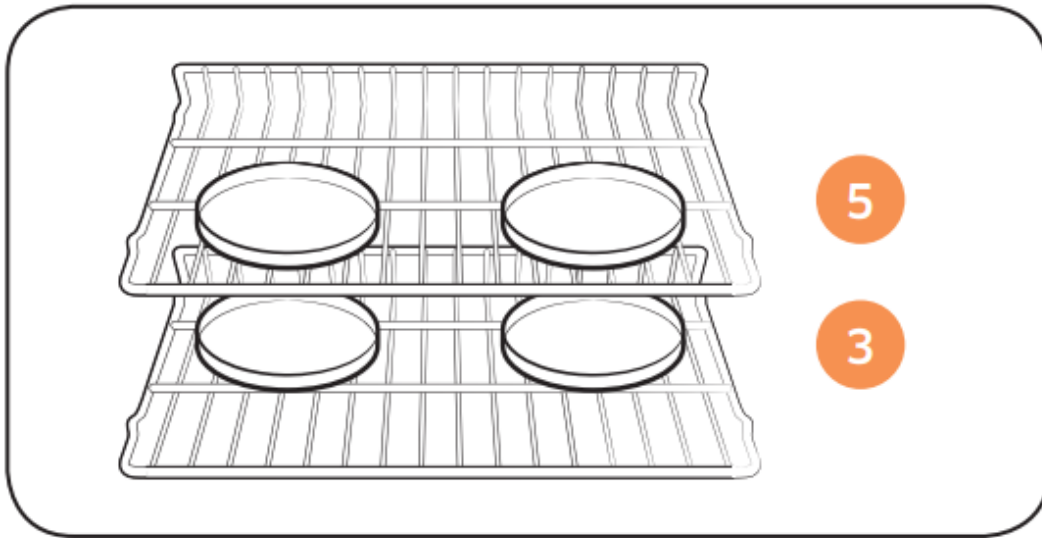

Multiple Oven Racks

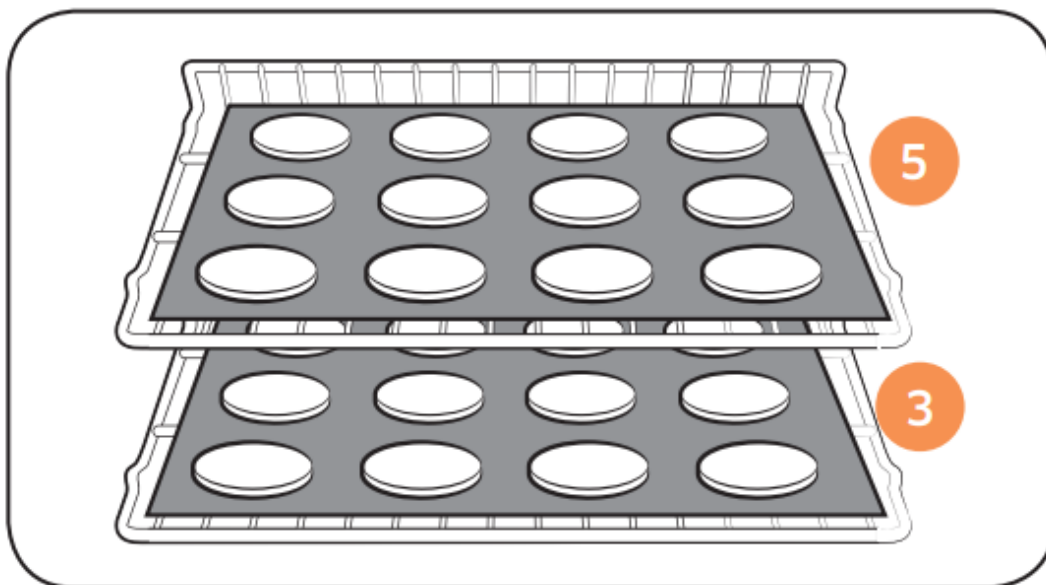

Using multiple oven racks

Type of Baking	Rack Positions
Cakes and cookies	3 and 5

Before using the racks

Each rack has stops that need to be placed correctly on the supports. These stops will keep the rack from coming completely out.

Removing the racks

1. Pull the rack straight out until it stops.
2. Lift up the front of the rack, and then pull it out.

Replacing the racks

1. Place the end of the rack on the support.
2. Tilt the front end up and push the rack in.

CAUTION

- Do not cover a rack with aluminum foil or place aluminum foil on the oven bottom. This will hamper heat circulation, resulting in poor baking, and may damage the oven bottom.
- Arrange the oven racks only when the oven is cool.

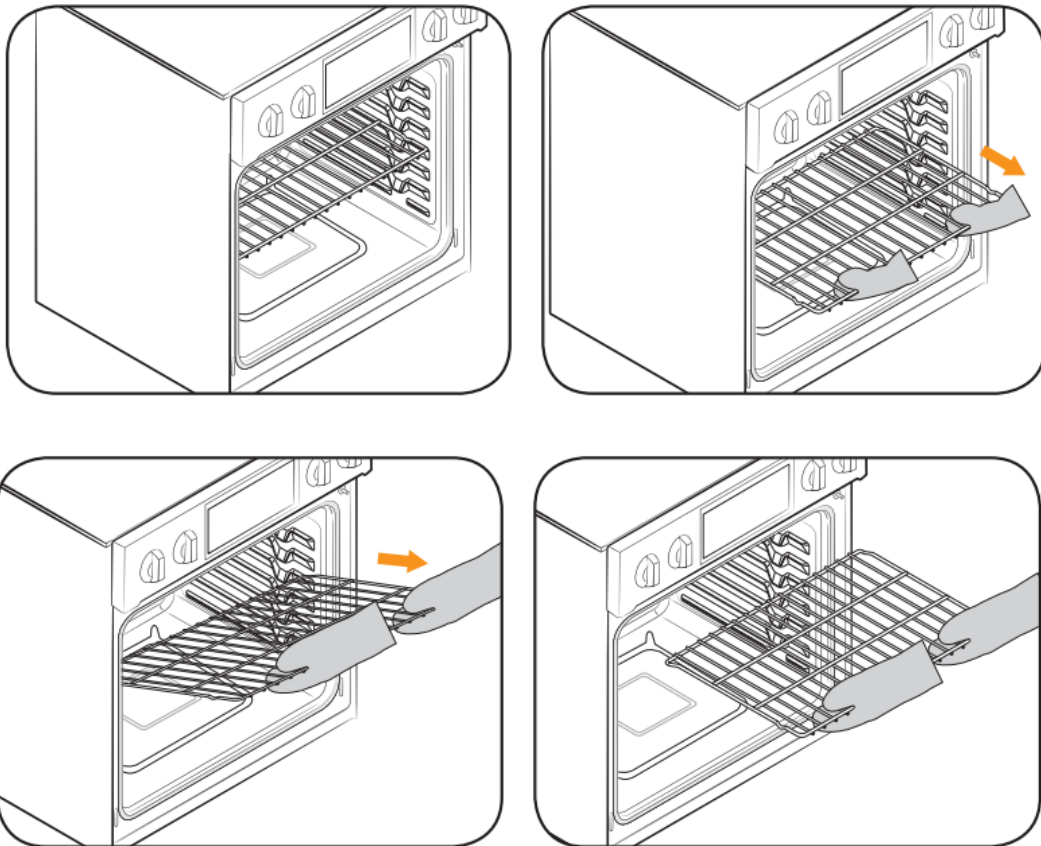

Using the gliding rack

Installing the Gliding rack

- With the Gliding rack in the Closed position and the oven off, carefully insert the Gliding Rack between the guides until the rack reaches the back.

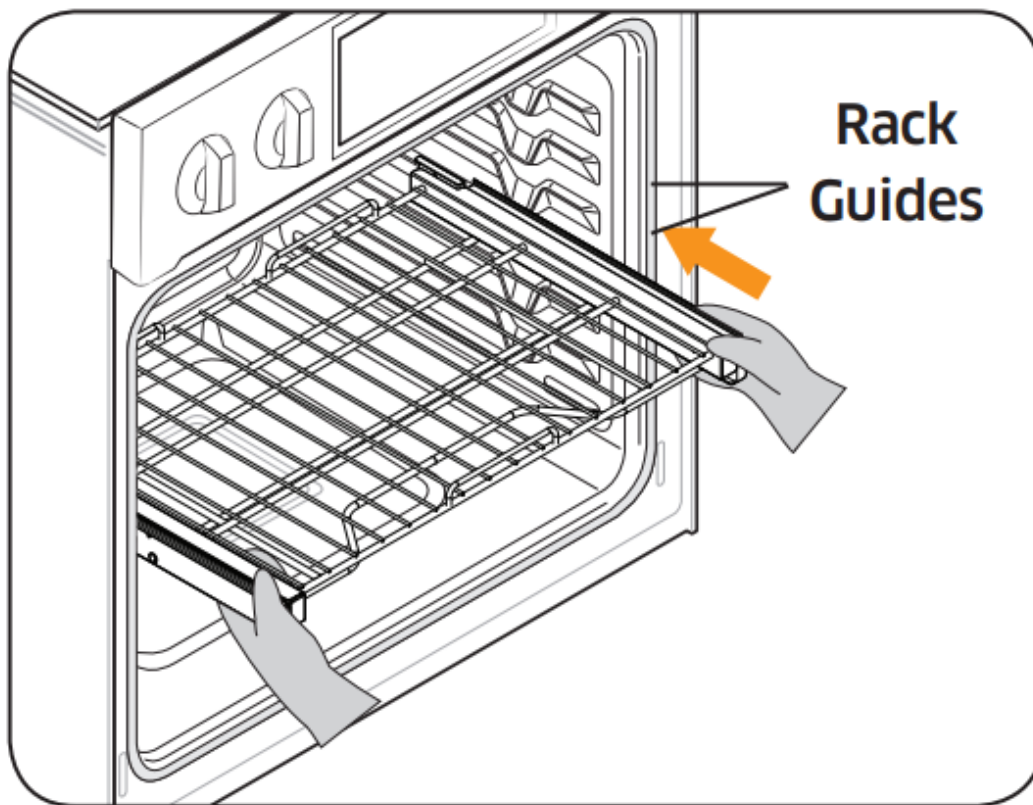

- When using the Gliding rack in the oven, be sure to pull on the handle of the rack only to slide it in and out. If you grasp the frame while using the rack, the entire Gliding rack will be removed. Make sure you use oven mitts when handling the Gliding rack during cooking.

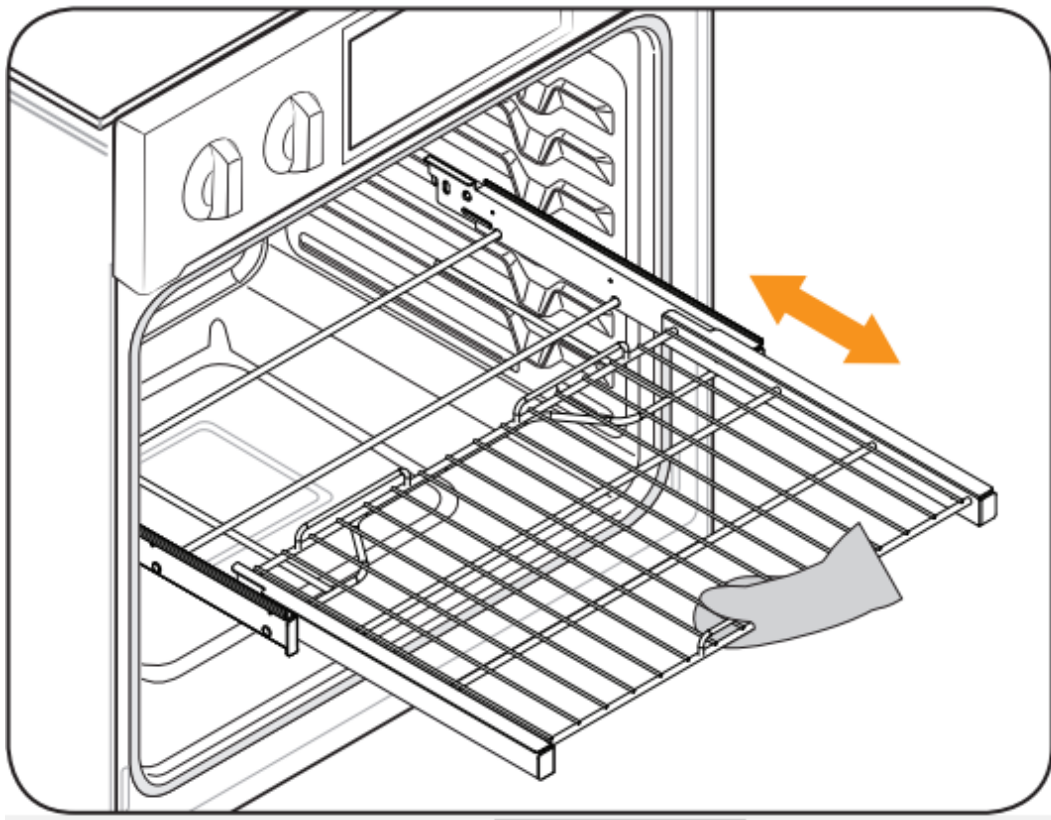

Removing the Gliding rack

- With the Gliding rack in the Closed position and the oven off and cool, grasp the rack and frame and pull both forward to remove.

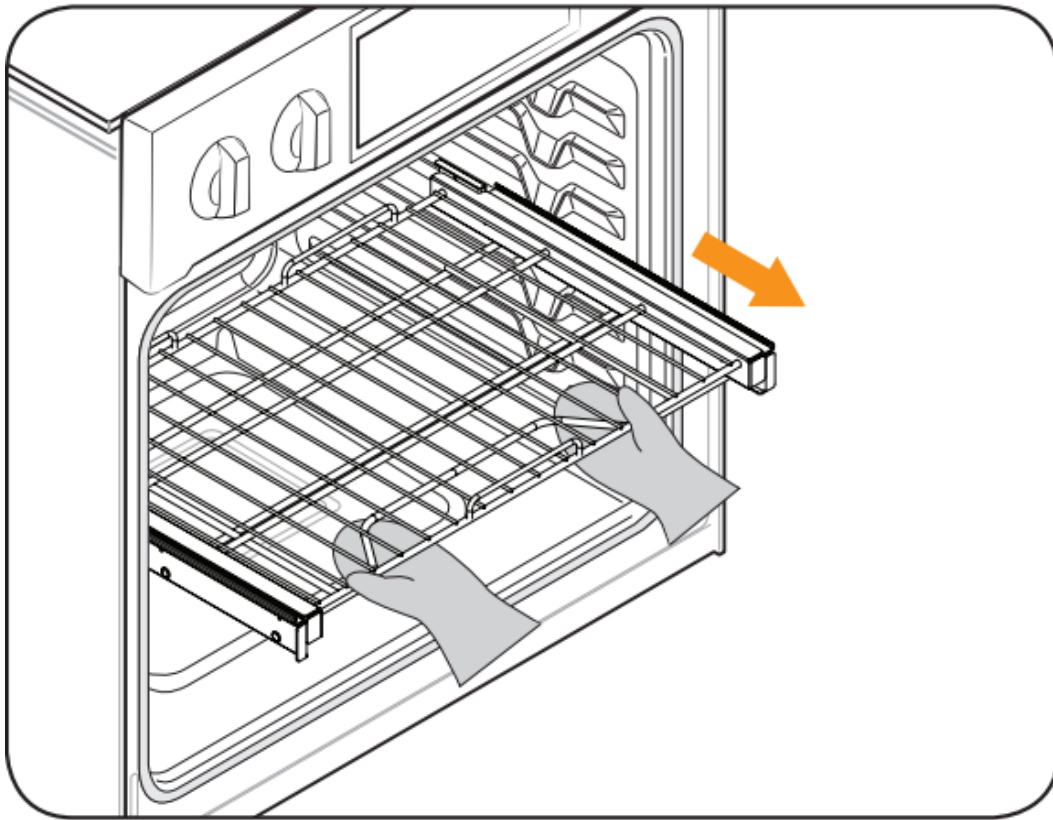

Do not install the Gliding rack directly above the Wire rack. You will not be able to install it properly and the rack could fall.

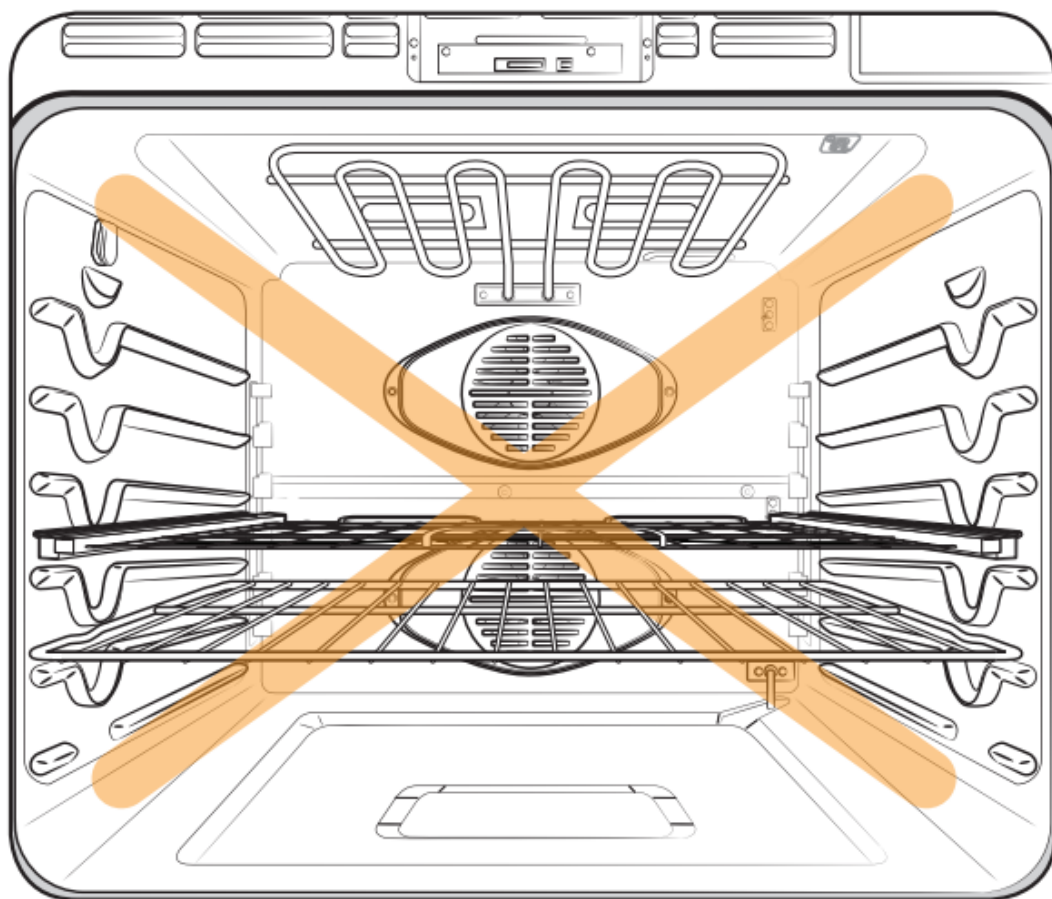

Using the divider

- To use twin mode operation, insert the divider.
- Handle the divider with both hands.
- Use oven gloves when inserting or removing the divider.

To Install the Divider into the Upper Oven Cavity

1. Insert the divider into the 4th rack position of the cavity.
2. Push the divider in until its back end rests against the back of the cavity

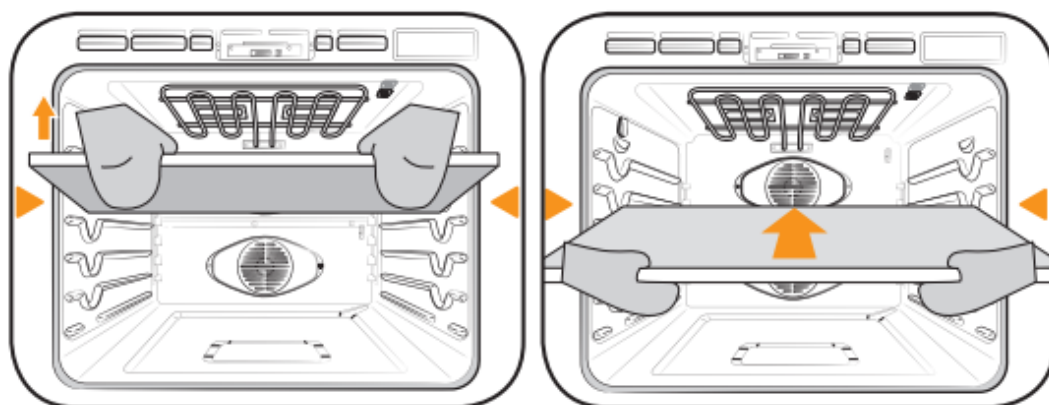

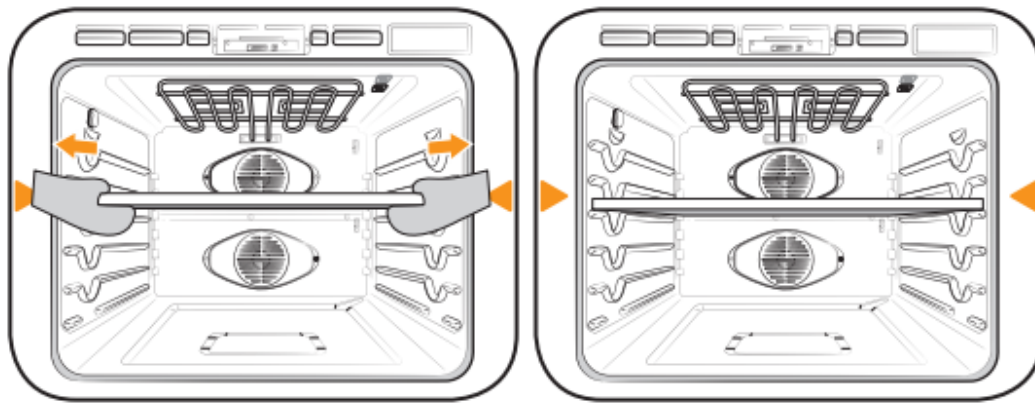

Using the clean feature

The Clean feature has four selections: Self-Clean, Hybrid Clean, Descal, and Draining.

Self Clean

This self-cleaning oven uses high temperatures (well above cooking temperatures) to burn off leftover grease and residue completely or reduce them to a finely powdered ash that you can wipe away with a damp cloth.

Before a self cleaning cycle

- We recommend venting your kitchen with an open window or using a ventilation fan or hood during the selfcleaning cycle.
- Remove the wire rack, broil pan, broil pan insert, all cookware, and any aluminum foil from the oven.
- Wipe up debris from the oven bottom. (Fig. 1)
- The silver-colored oven racks can be self-cleaned, but they will darken, lose their luster, and become hard to slide.
- Residue on the front frame of the oven and outside the gasket on the door will need to be cleaned by hand. Clean these areas with hot water, soap-filled steel-wool pads, or cleansers such as Soft Scrub. Rinse well with clean water and dry.
- Do not clean the gasket. The fiberglass material of the oven door gasket cannot withstand abrasion. It is essential for the gasket to remain intact. If you notice it becoming worn or frayed, have it replaced. (Fig. 2)
- Make sure the oven light cover is in place and the oven light is off.

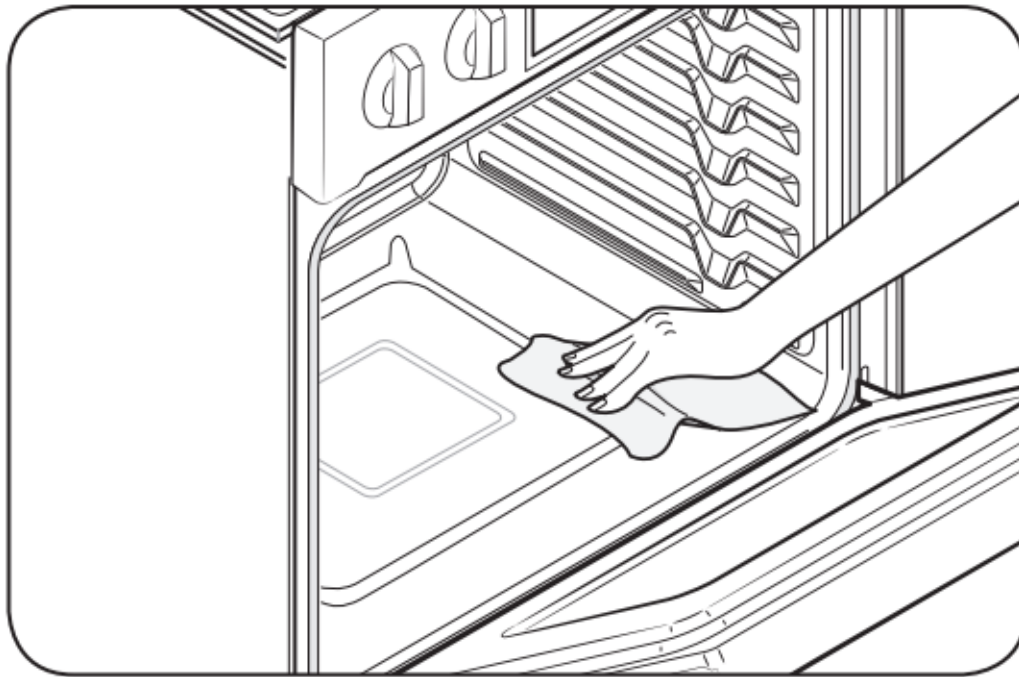

Fig. 1

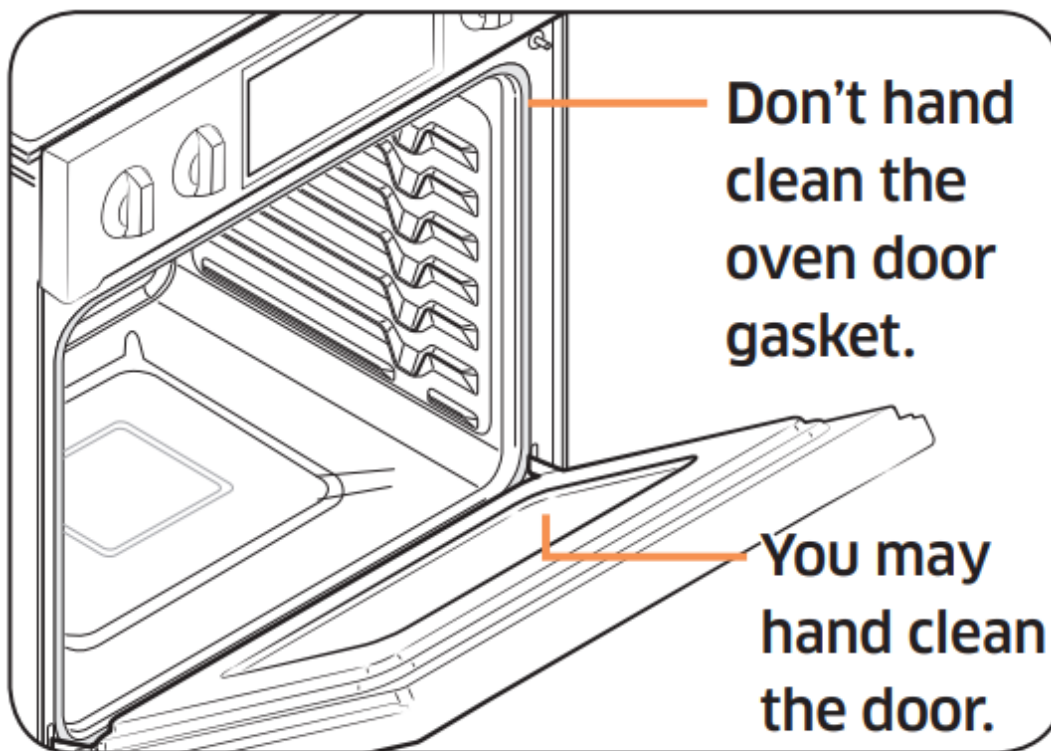
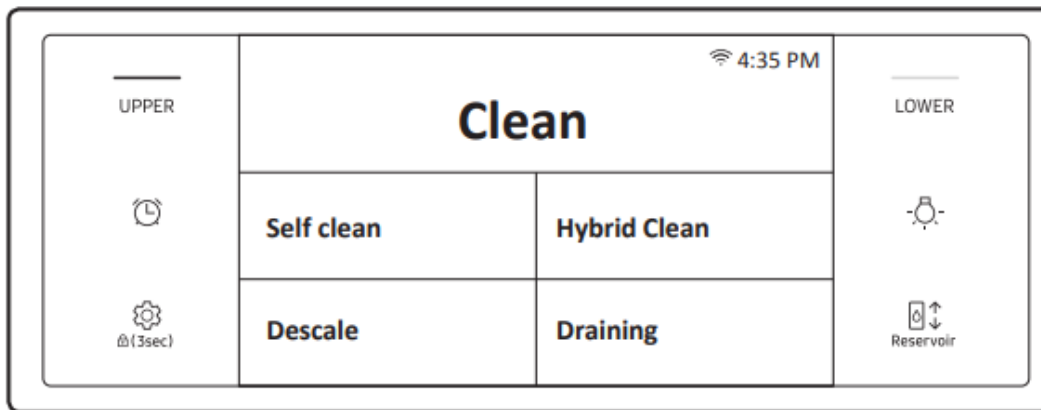

Fig. 2

How to run a self cleaning cycle

1. Turn the Mode knob to Clean. The display will show 4 cleaning selections.



2. Tap Self Clean.

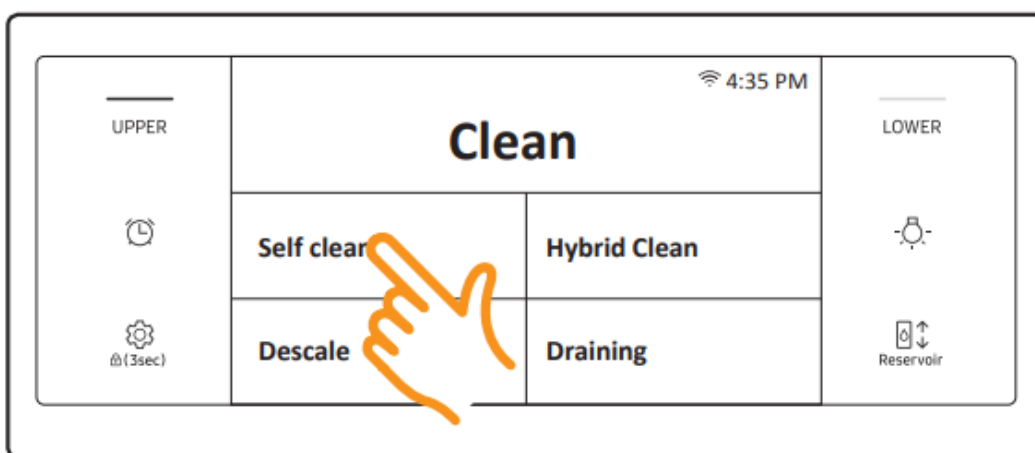

3. Tap Clean Time.

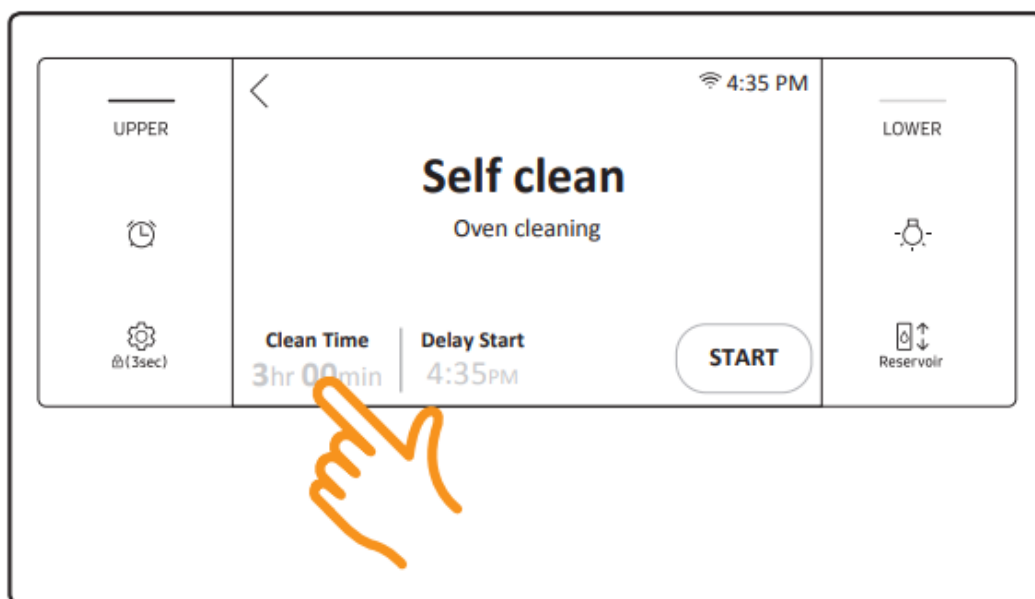

4. Flick the screen to set the clean time. You can choose 2 hours, 3 hours, or 5 hours. (The default is 3h).

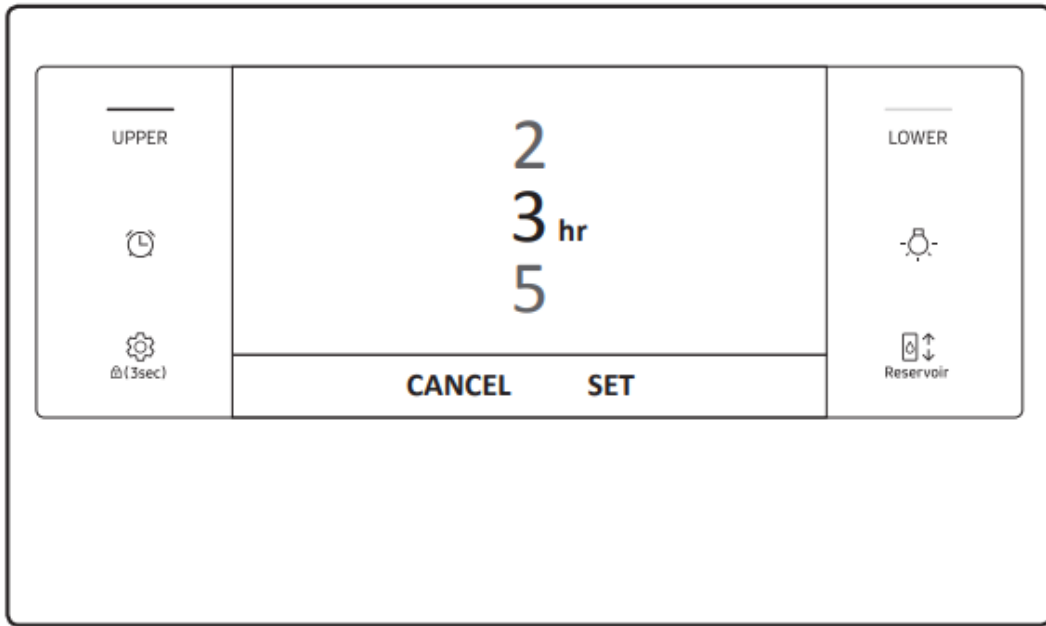

5. Tap SET.

6. If you don't want to use the Delay Start feature, go to Step 8. Otherwise, tap Delay Start, and then go to Step 7.

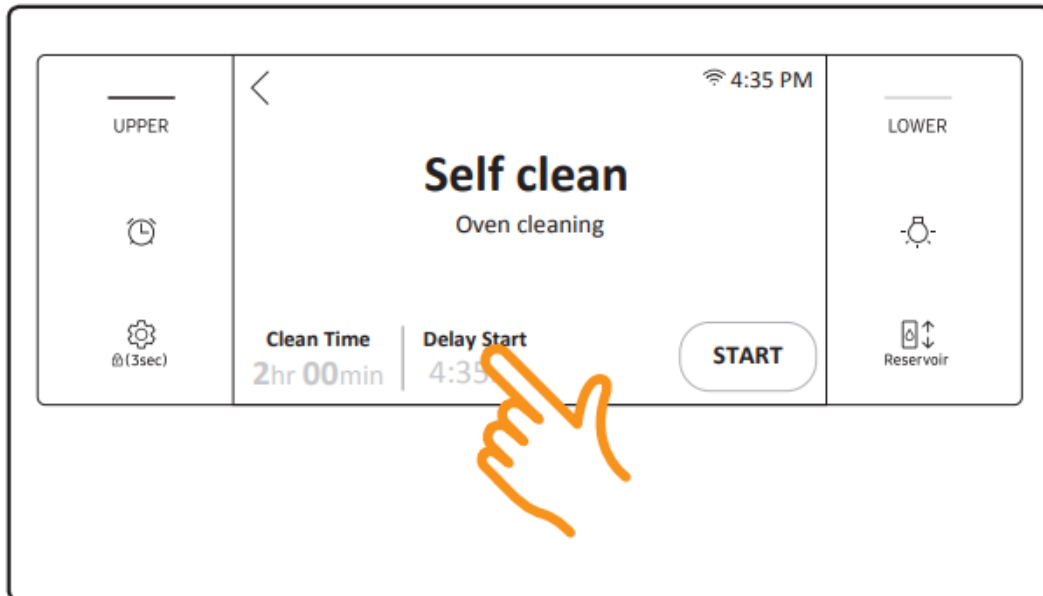

7. Set the time you want self-cleaning to start, and then tap Set.

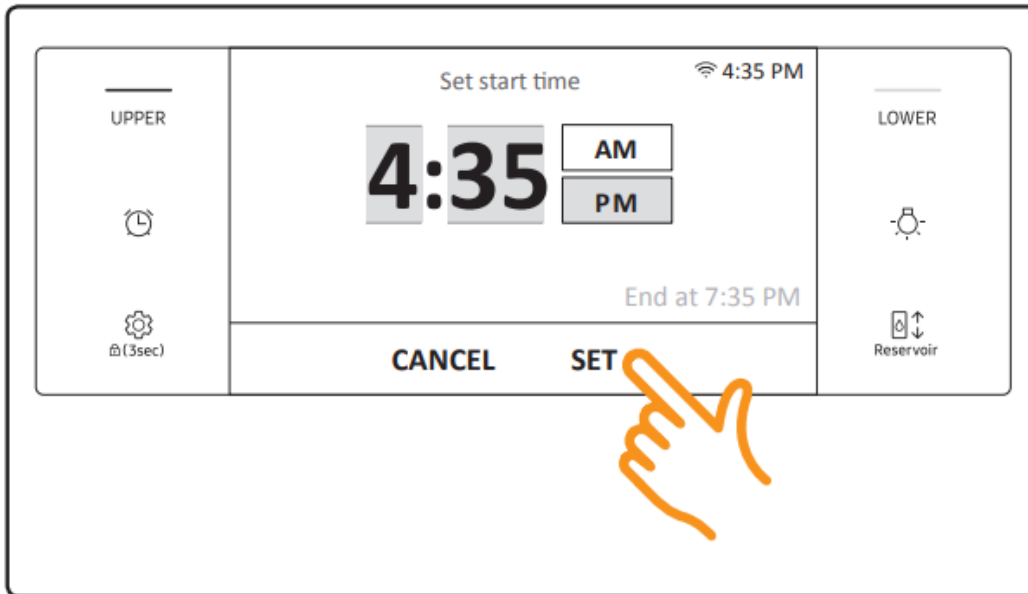

8. Tap START to begin self-cleaning. The motor-driven door lock will engage automatically. Important: Both doors lock when you run a self cleaning cycle on either oven.

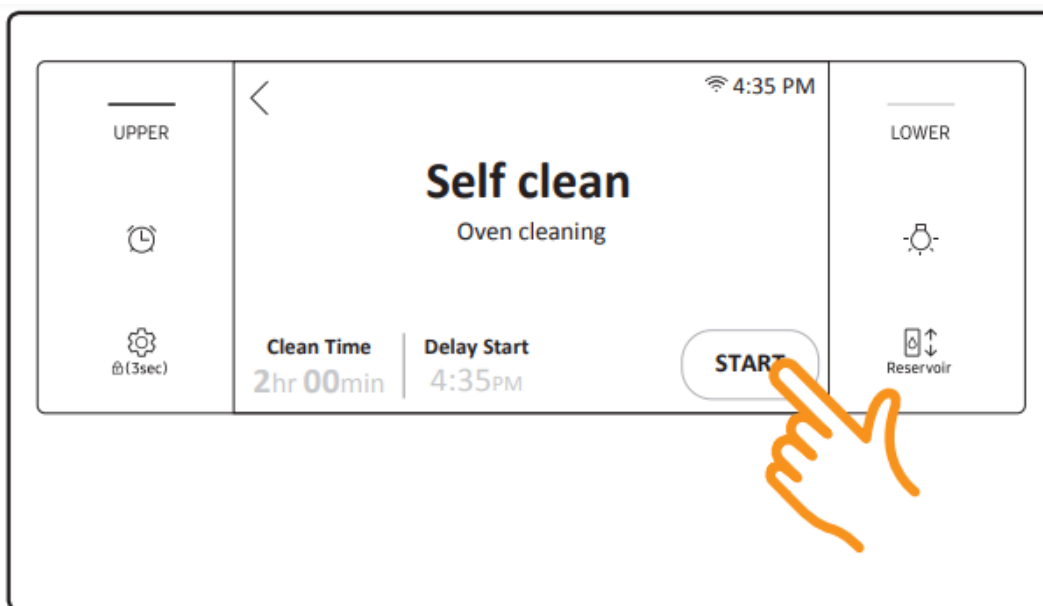

9. If you need to stop or interrupt a self cleaning cycle, tap CANCEL

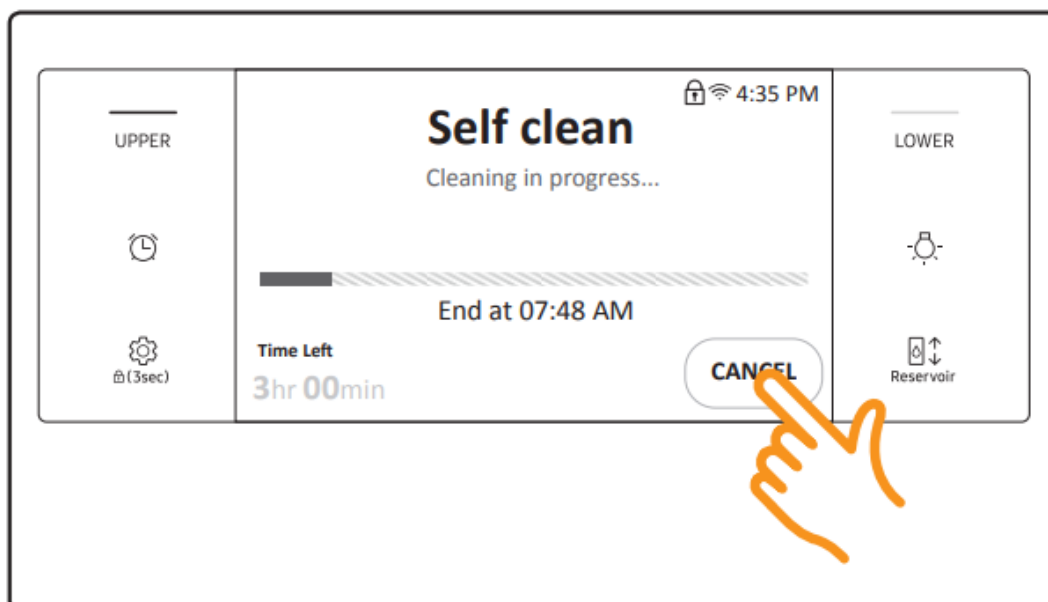

After a self-cleaning cycle

- You may notice some white ash in the oven. Wipe it up with a damp cloth after the oven cools. (If white spots remain, remove them with a soap-filled steel wool pad and rinse thoroughly with a vinegar and water mixture.)
- If the oven is not clean after one cycle, repeat the cycle.
- You cannot set the oven for cooking until the oven is cool enough for the door to unlock.

Hybrid Clean

The Hybrid cleaning function saves time and energy by removing leftover grease and residue that you can wipe away with a damp cloth

Before a Hybrid cleaning cycle

- Remove the wire rack, broil pan, broil pan insert, all cookware, and any aluminum foil from the oven.
- Wipe up debris from the oven bottom. (Fig. 1)
- The silver-colored oven racks can be Hybrid cleaned, but they will darken, lose their luster, and become harder to slide.
- Residue on the front frame of the oven and outside the gasket on the door will need to be cleaned by hand. Clean these areas with hot water, soap-filled steel-wool pads, or cleansers such as Soft Scrub. Rinse well with clean water and dry.
- Do not clean the gasket. The fiberglass material of the oven door gasket cannot withstand abrasion. It is essential for the gasket to remain intact. If you notice it becoming worn or frayed, have it replaced. (Fig. 2)

- Make sure the oven light cover is in place and the oven light is off

How to run a hybrid cleaning cycle

1. Turn the Mode knob to Clean. The display will show 4 cleaning selections.

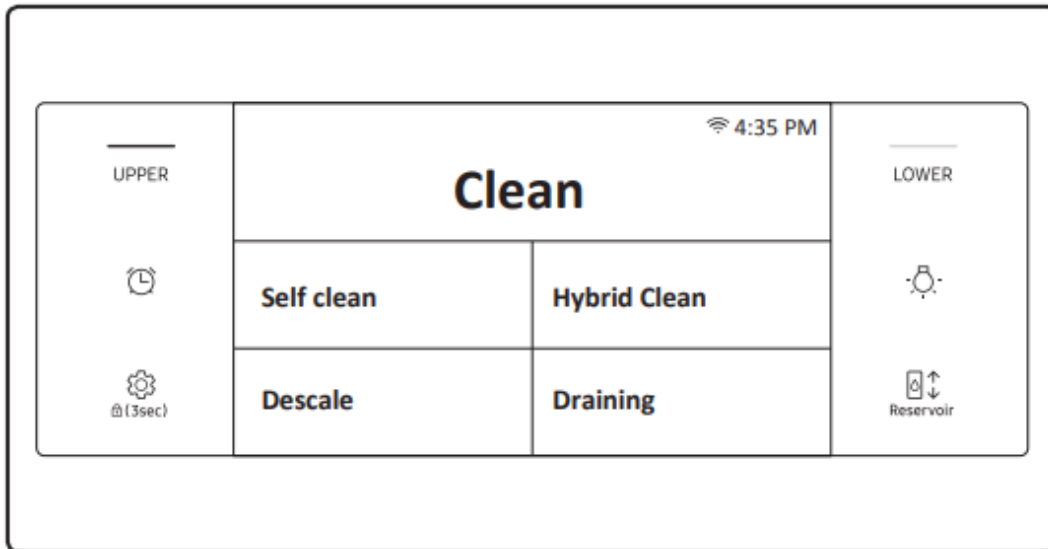

2. Tap Hybrid Clean

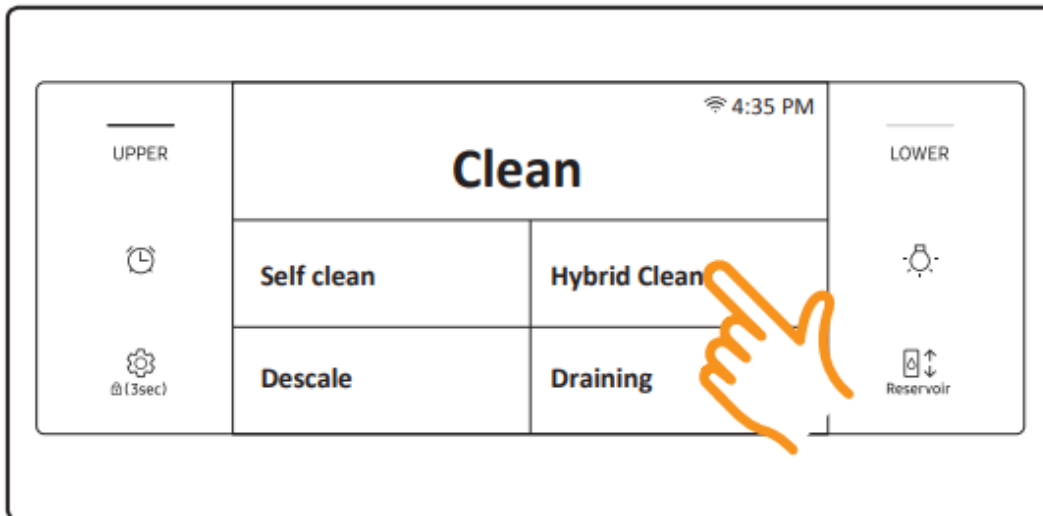

3. Tap the Clean Time area to adjust the clean time. The clean time adjustment screen appears. You can set the clean time to 1hr 30min or 2hr 30min.

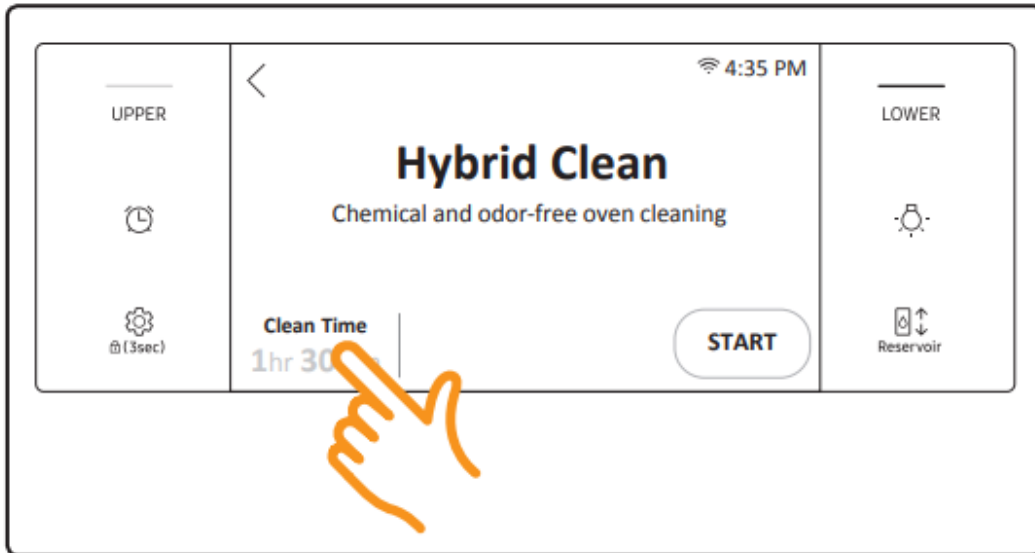

4. Tap SET. The clean time adjustment screen closes and the clean time information is displayed on the screen.

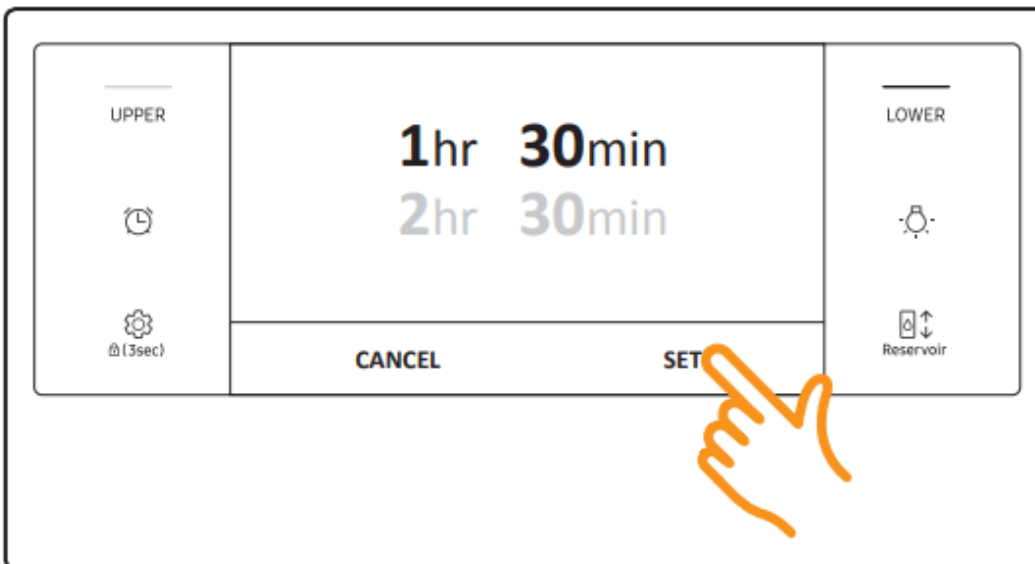

5. Tap START to begin Hybrid cleaning.

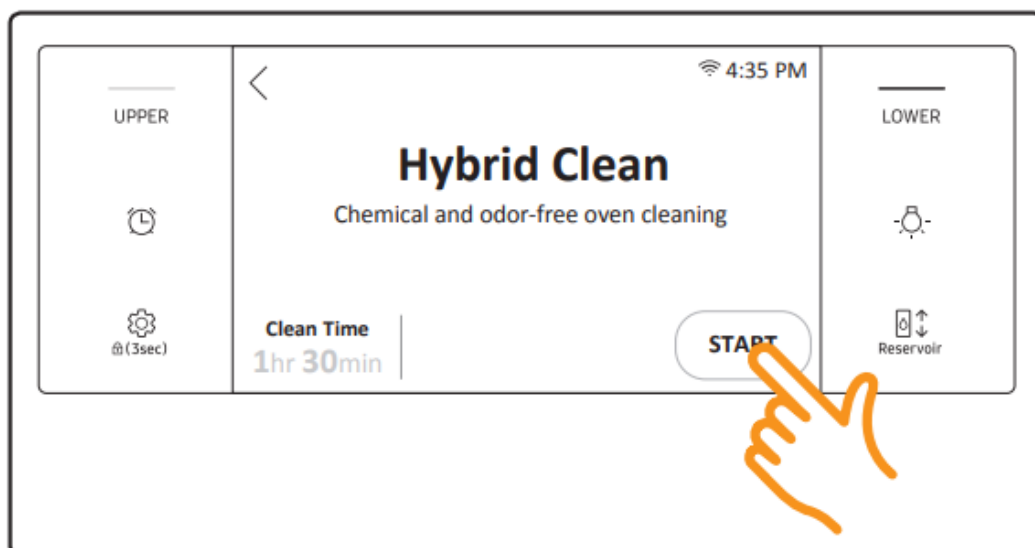

6. Follow the on-screen instructions. Hybrid cleaning will start automatically after the oven senses water in the water reservoir.

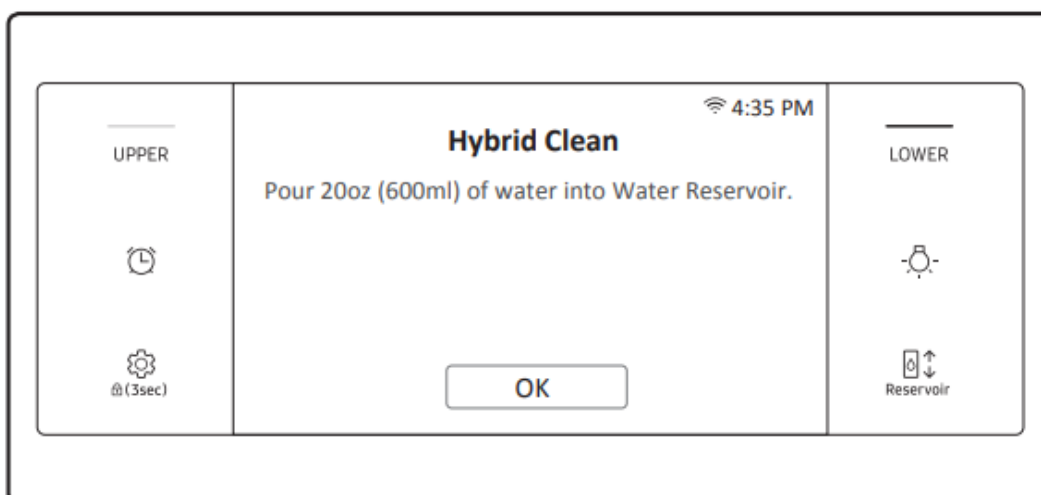

7. When Hybrid cleaning is complete, clean the oven's interior. There will be a significant amount of water remaining on the bottom of the oven after a Hybrid cleaning cycle. Remove the residual water with a sponge or soft dry cloth.

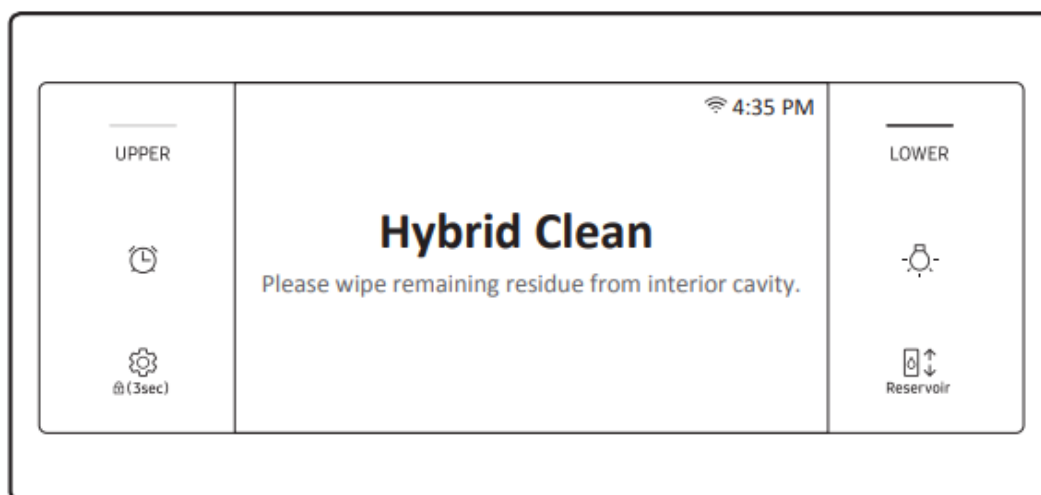

After a Hybrid cleaning cycle

- Take care when opening the door after a Hybrid cleaning procedure has ended. The water on the bottom is hot.
- Open the oven door and remove the remaining water with a sponge. Do not leave the residual water in the oven for any length of time. Wipe the oven clean and dry with a soft cloth. Do not forget to wipe under the oven door seal.
- Use a detergent-soaked sponge, a soft brush, or a nylon scrubber to wipe the oven interior. Remove stubborn residue with a nylon scourer. You can remove lime deposits with a cloth soaked in vinegar.
- If the oven remains dirty, you can repeat the procedure once the oven has cooled.
- For heavy residue, such as grease left over from roasting, we recommend that you rub detergent into the residue before activating the Hybrid cleaning function.
- After cleaning, leave the oven door ajar at a 15° angle to allow the interior enamel surface to dry thoroughly

Descal (Upper oven only)

If you use Steam Bake or Steam Roast functions frequently, we recommend descaling regularly to remove minerals from the oven that may affect the taste or quality of food cooked. When running a descaling cycle, use only descaling agents that are specific to steam ovens or coffee machines.

How to run a descale cycle

1. Turn the Mode knob to Clean. The display will show 4 cleaning selections.

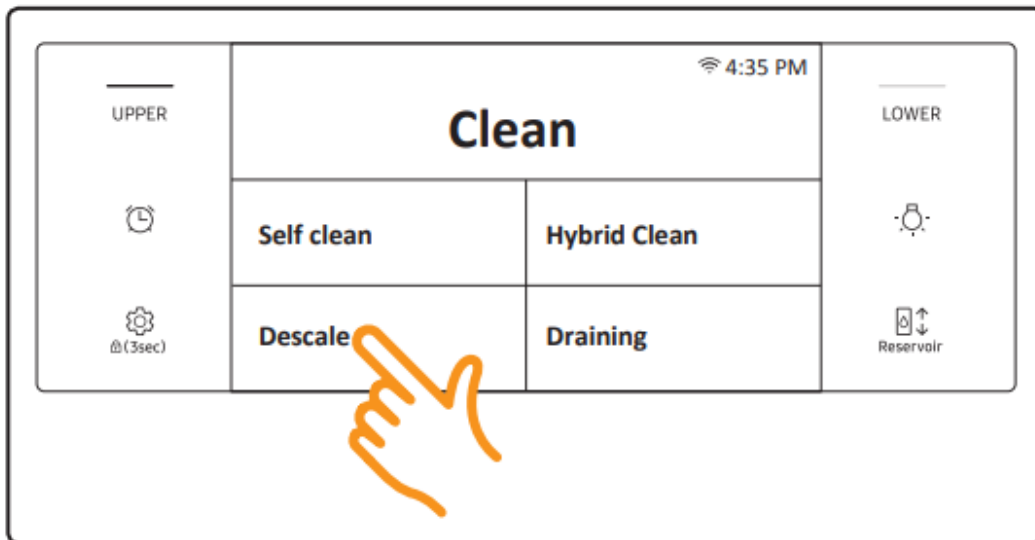

2. Tap Descal.

3. Tap START.

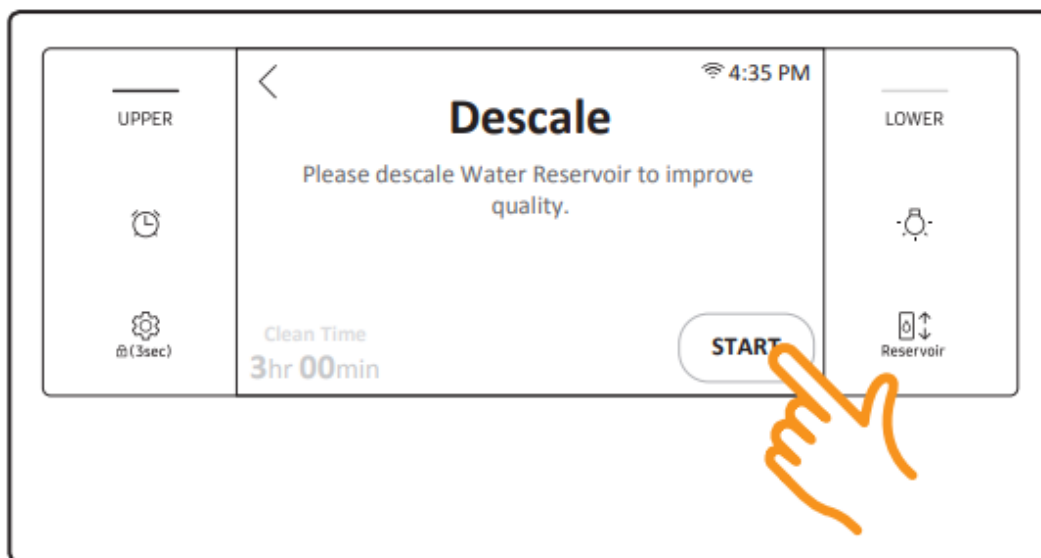

4. Follow the on-screen instructions. It takes 3 hours to complete the cycle.

- Empty and clean the water reservoir, and then fill it with 1.7 oz (50 ml) of descaling agent and 13.5 oz (400 ml) of drinkable water.

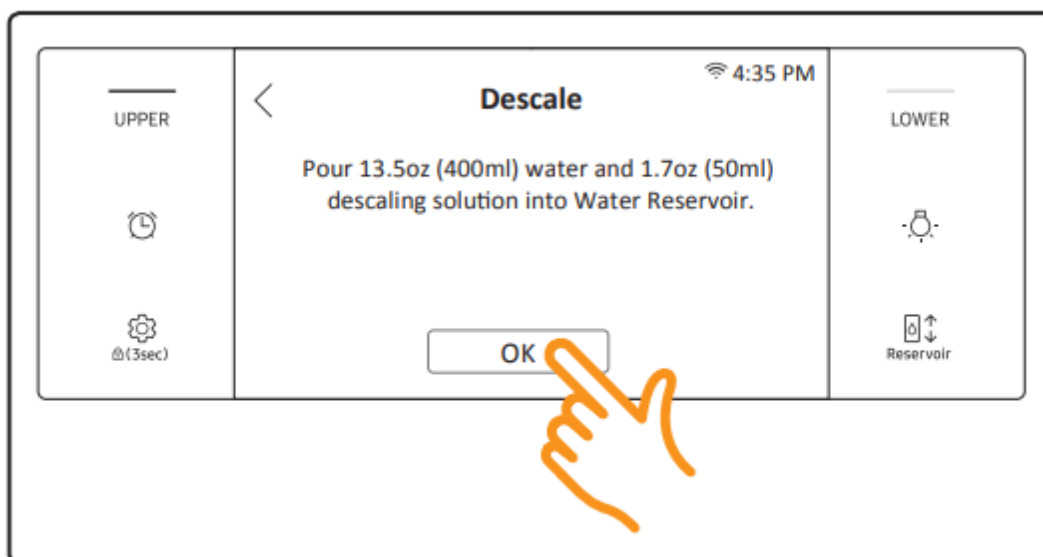

5. When descaling is complete, the oven drains water automatically.

6. Use oven gloves to remove and empty the water reservoir, and then refill it with 22 oz (650 ml) of drinkable water for rinsing.



7. Follow the on-screen instructions, and then tap OK to start rinsing.

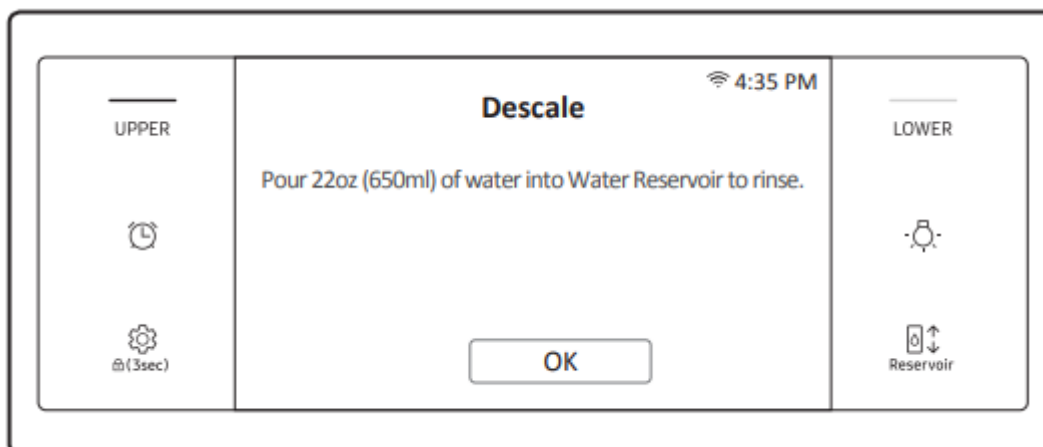

8. When rinsing is complete, use oven gloves to empty and clean the water reservoir.

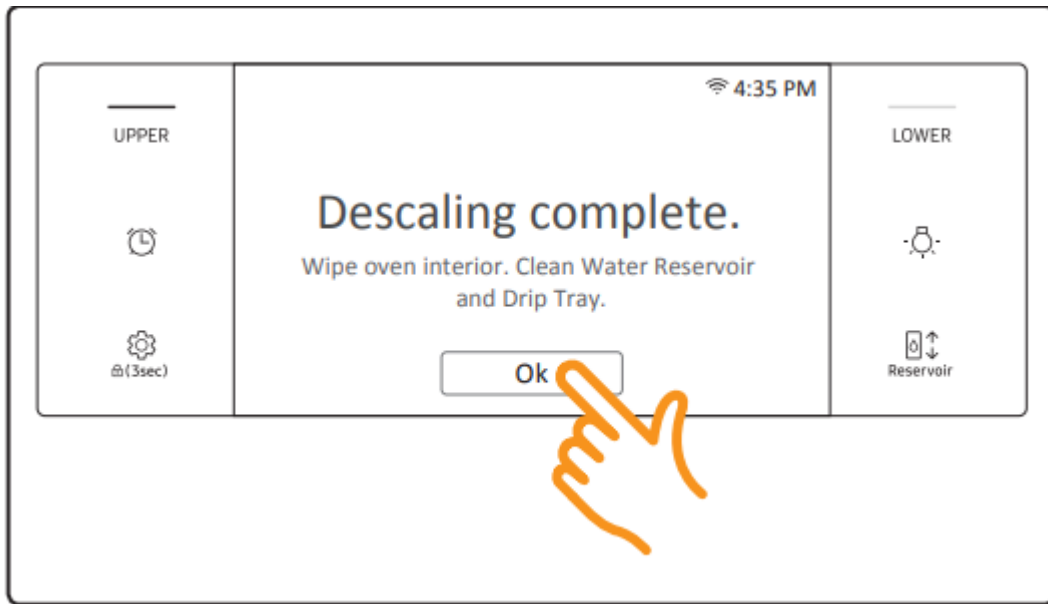

Draining (Upper oven only)

When a steam function is complete, you must drain the remaining water to prevent the water from affecting other cooking modes. To drain the water, follow these steps:

How to run a draining

1. Turn the Mode knob to Clean. The display will show 4 cleaning selections.
2. Tap Draining.

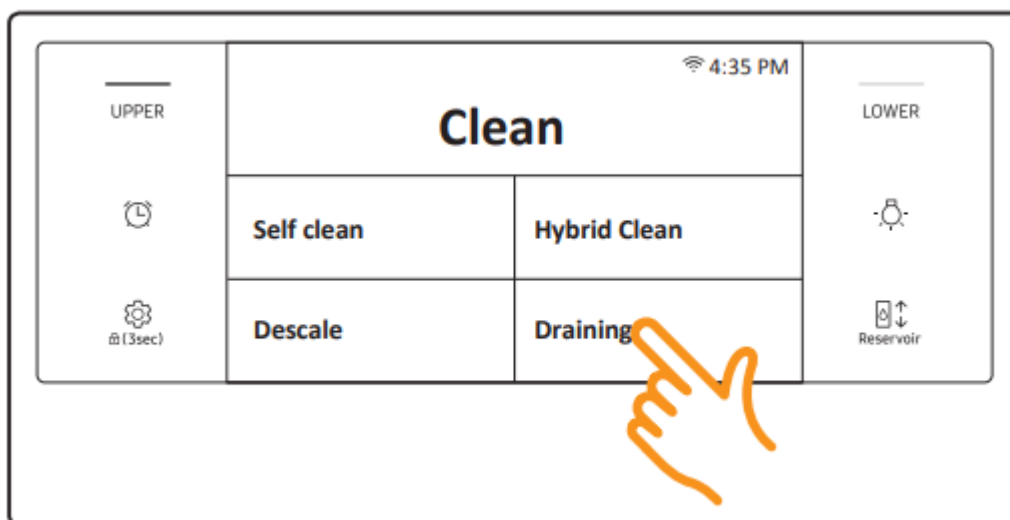

3. Tap START. The oven drains water from the steam generator to the water reservoir.

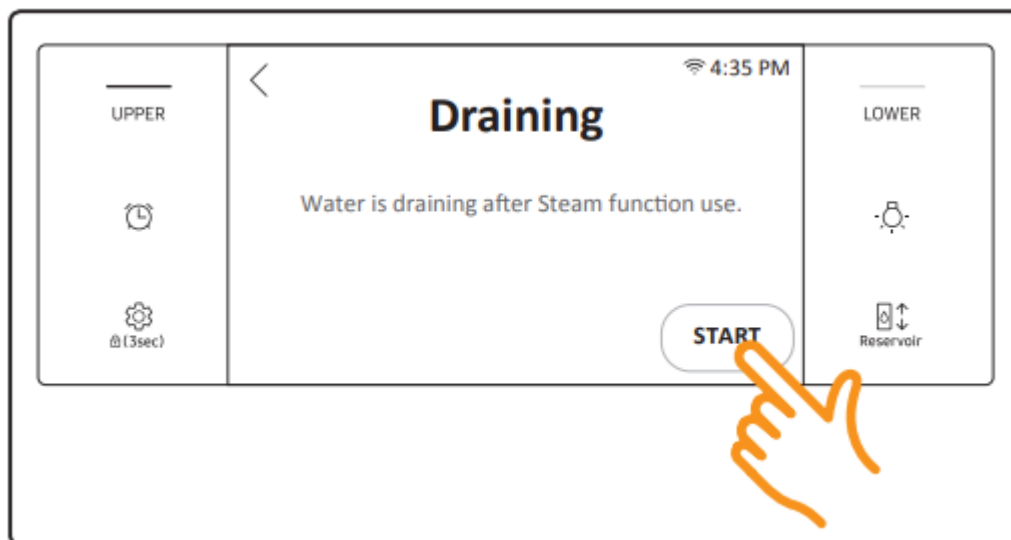

4. When draining is complete, use oven gloves to remove and empty the water reservoir.

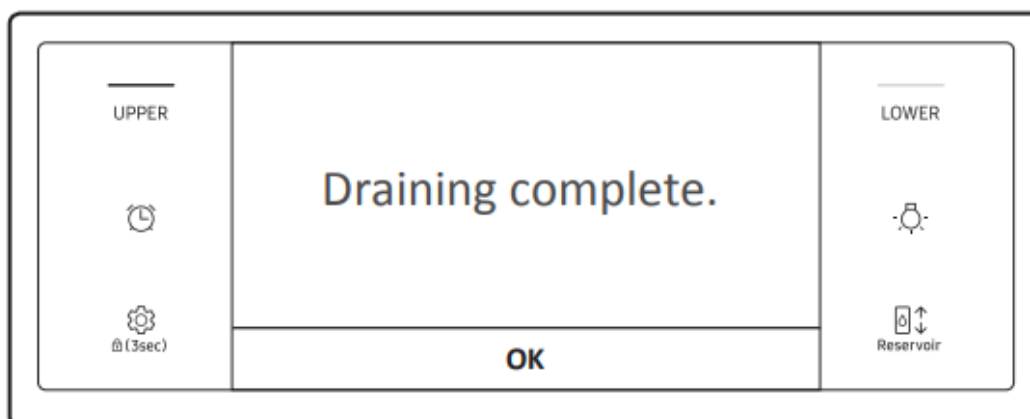
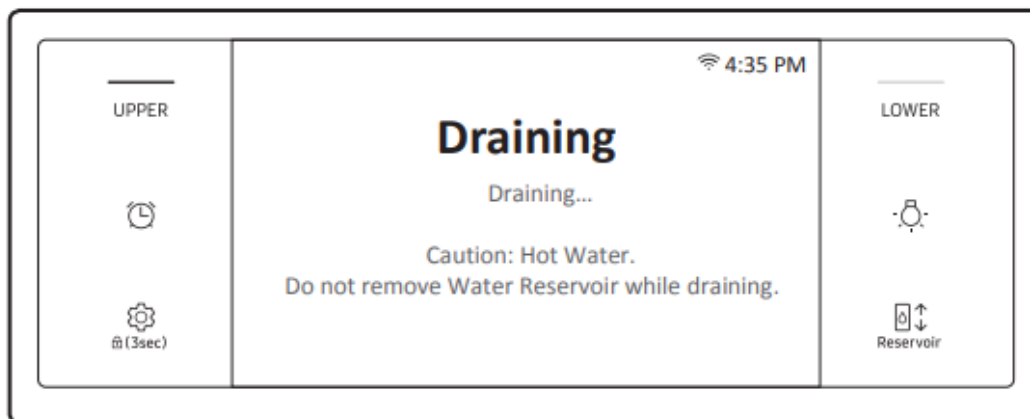

Settings

In Settings, you can change the default settings to your preference or diagnose problems with the network connection.



Tap Settings  (3sec) . The display will show the Setting item.

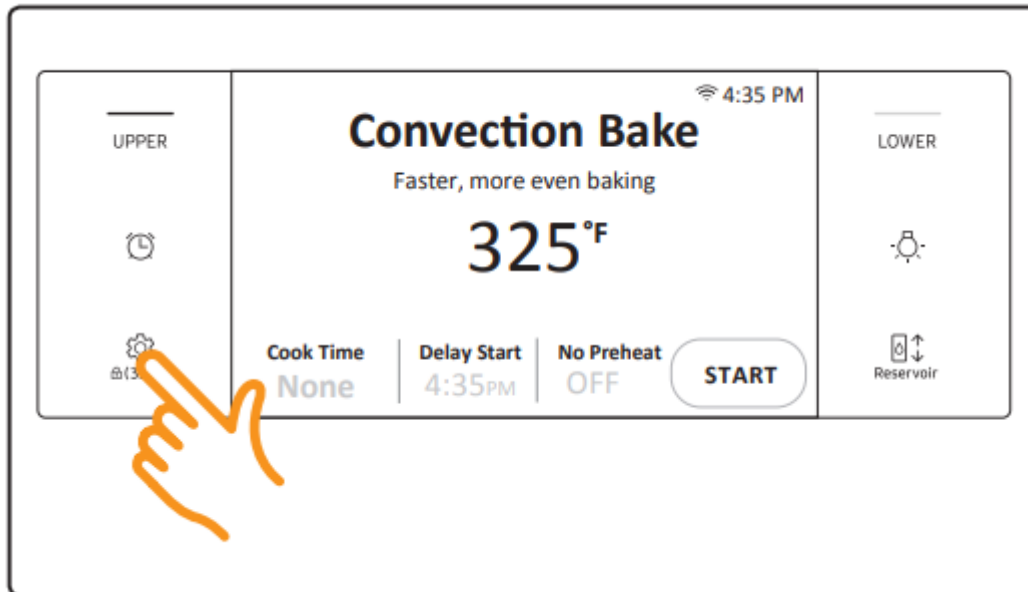

Wi-Fi

To enable a Wi-Fi connection



1. Tap Settings  (3sec) > Wi-Fi, and then tap ON in the right screen.
2. Tap Wi-Fi, and then tap a Wi-Fi network in the list that appears.
3. You will be prompted to provide a password for a secure network. Enter the password.

To manually input an IP



1. Tap Settings  (3sec) > Wi-Fi, and then tap ON in the right screen.
2. Tap Wi-Fi, and then tap Add Network.
3. Enter an IP manually, and then tap CONNECT to apply your settings

Display

1. Brightness You can change the brightness of the display screen.



- Tap Settings  (3sec) > Display > Brightness, and then use the bar next to Brightness to adjust the brightness of the screen.

2. Screen saver If screen saver is turned off, the Clock theme and Timeout menu are disabled.



- Tap Settings  (3sec) > Display > Screen saver, and then tap OFF in the right screen.

3. Clock theme



- Tap Settings  (3sec) > Display > Clock theme, and then tap in the right screen. You can select a theme.

4. Timeout



- Tap Settings  (3sec) > Display > Timeout, and then tap in the right screen. You can select a time from 5 minutes to 60 minutes.

Date & Time

To enable automatic date and time

1. Turn on the Wi-Fi connection.



2. Tap Settings  (3sec) > Date & Time, and then tap Date & Time.

3. Tap ON in the right screen. The data and time are set automatically.

To manually input the date and time



1. Tap Settings  (3sec) > Date & Time, and then tap Date & Time.

2. Tap OFF in the right screen. Time zone, set date, and set time are activated.

3. You can set the time zone, date, and time.

To change the time format



1. Tap Settings  (3sec) > Date & Time > Select time format, and then tap in the right screen.

2. You can select 12-hour clock or 24-hour clock.

Language

Choose a display language.



1. Tap Settings  (3sec) > Language, and then tap in the right screen.
2. You can select English, Spanish, or French.

Volume

Adjust the volume level for beeps and melodies.



- Tap Settings  (3sec) > Volume, and then use the bar next to Volume to adjust the volume.

Temp

1. Temp unit You can program the oven control to display the temperature in Fahrenheit or Celsius. The oven has been preset at the factory to display in Fahrenheit.



- Tap Settings  (3sec) > Temp > Temp unit, and then tap in the right screen. You can select °C or °F.

2. Temp adjust The temperature in the oven has been calibrated at the factory. When first using the oven, be sure to follow recipe times and temperatures. If you think the oven is too hot or too cool, you can correct the temperature in the oven. Before correcting, test a recipe by using a temperature setting that is higher or lower than the recommended temperature. The baking results should help you to decide how much of an adjustment is needed. The oven temperature can be adjusted ± 35 °F (± 19 °C).



- Tap Settings  (3sec) > Temp > Temperature Adjust, and then tap in the right screen. You can increase or decrease the temperature by 35 °F (19 °C).

12 hour energy Saving

If you accidentally leave the oven on, this feature will automatically turn off the oven after 12 hours during baking functions or after 3 hours during a broil function.



1. Tap Settings  (3sec) > 12 hour energy Saving, and then tap ON in the right screen.

2. The 12 hour energy saving icon will appear in the indicator area.

Easy connection

Easy connection enables you to easily configure the network settings including the authentication procedure.

Help

Help provides useful tips and explanations on a specific item that you select.

1. Troubleshooting

- Tap a checkpoint directly on the screen, and try the suggestions.

2. Guide for first use

- Provides simple instructions on the basic use of the oven.

About device

You can see information about the oven and do a software update. To update the software:



1. Tap Settings  (3sec) > About device > SW update, and then tap Update in the right screen.

2. Tap INSTALL. The software is updated and the system restarts automatically.

Sabbath

You can set Sabbath mode. See the Using the sabbath feature section on the next page.

Demo mode

This option is for use by retail establishments for display purposes only. (The heating element does not operate.)



1. Tap Settings  (3sec) > Demo mode, and then tap ON in the right screen.

2. The Demo mode indicator appears on screen.

Using the sabbath feature

How to use the Sabbath feature

1. Turn the Mode knob to Bake mode.

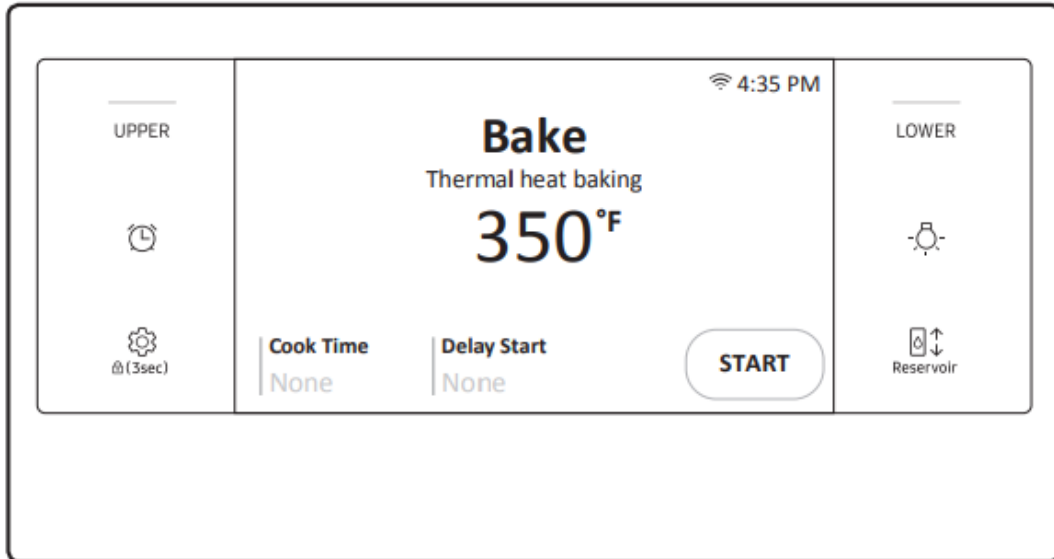

2. Set the temperature and cook time you want.

3. Tap START.

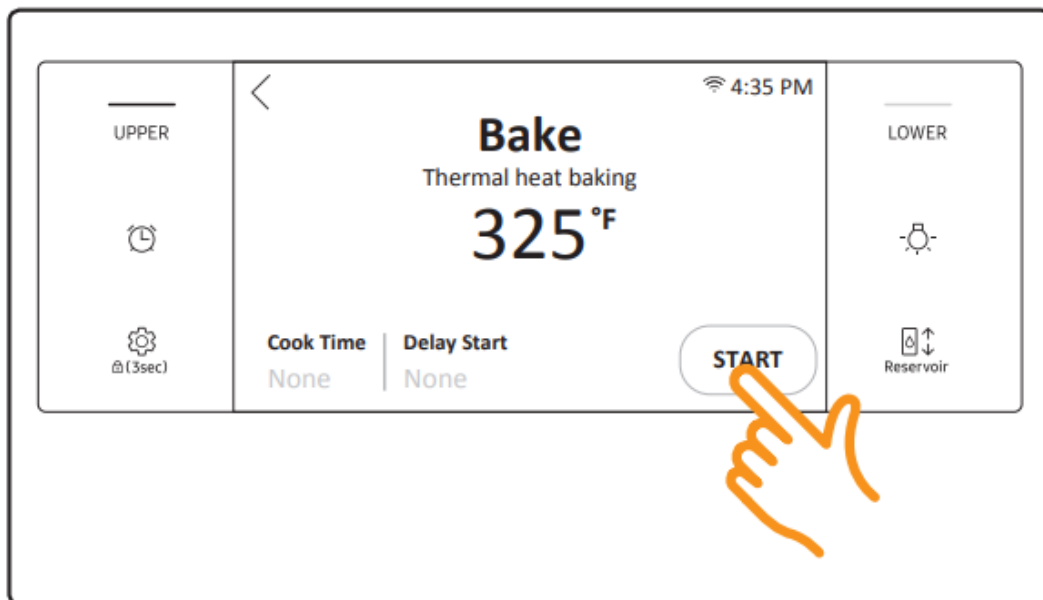

4. Tap Settings  (3sec) > Sabbath, and then tap Sabbath to use the Sabbath feature. The oven will not beep or display any further changes. You may change

the oven temperature once baking has started. Remember that the oven will not beep or display any further changes once the Sabbath feature is engaged.

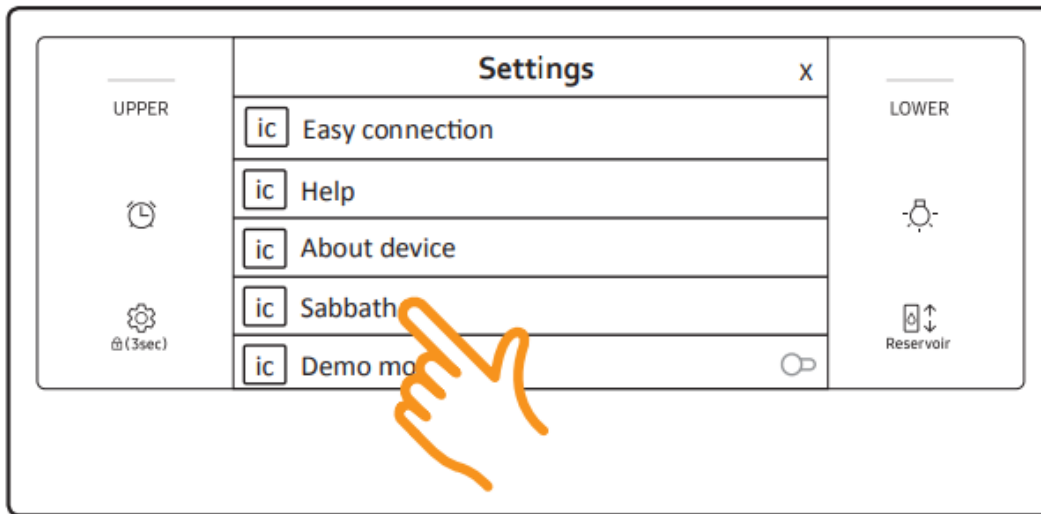

5. You can turn the oven off at any time by touching and holding Sabbath Off for 3 seconds or turning the Mode knob to the OFF position. Note that this does not turn Sabbath mode off.

6. To turn Sabbath mode off, touch and hold Sabbath Off for 3 seconds.

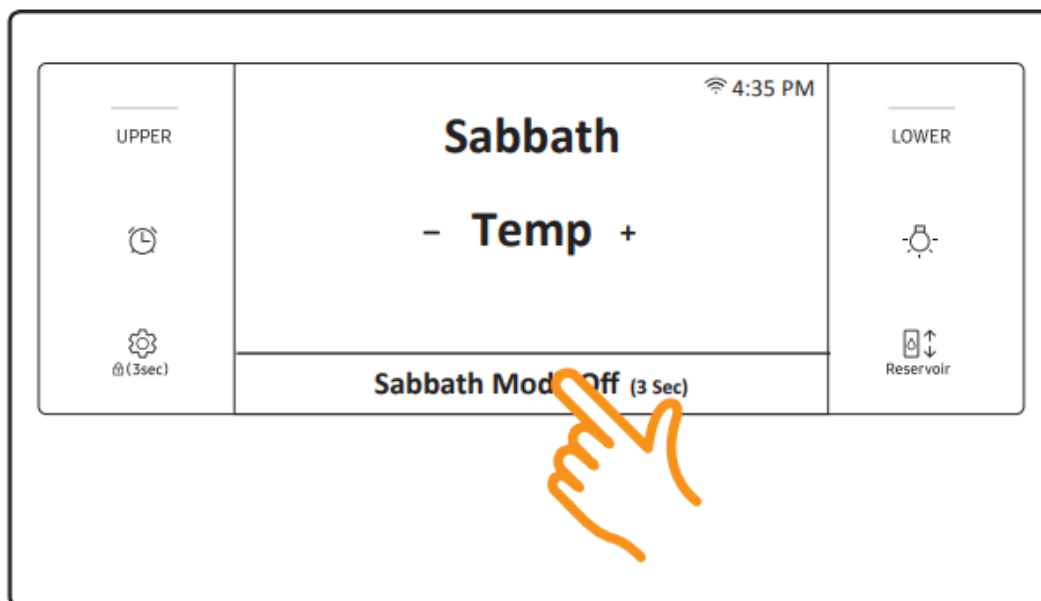

Maintaining your appliance

Care and cleaning of the oven

Cleaning painted parts and decorative trim

- For general cleaning, use a cloth with hot, soapy water.

- For more difficult residue and built-up grease, apply a liquid detergent directly onto the area and leave for 30 to 60 minutes. Wipe with a damp cloth and dry. Do not use abrasive cleaners on any oven surface. They can be scratched.

Cleaning stainless steel surfaces

1. Shake a bottle of Stainless Steel Appliance Cleaner or Polish well.
2. Place a small amount of stainless steel appliance cleaner or polish on a damp cloth or damp paper towel.
3. Clean a small area, rubbing with the grain of the stainless steel if applicable.
4. Dry and buff with a clean, dry paper towel or soft cloth.
5. Repeat as necessary

Oven racks

- If the racks are left in the oven during a self-cleaning cycle, their color will turn slightly blue and the finish will be dull. After the self-cleaning cycle is complete and the oven has cooled, rub the sides of the racks with wax paper or a cloth containing a small amount of oil. This will help the racks glide more easily on their tracks.
- Gliding racks may be cleaned by hand with an abrasive cleaner or steel wool. During cleaning, be careful not to allow water or cleaner to enter the slides on the sides of rack

To lubricate the slides of the gliding rack

1. Remove the rack from the oven. See removing the gliding rack in the Using the gliding rack section on page 39.
2. Fully extend the rack on a table or countertop. Newspaper may be placed underneath the rack for easy cleanup.
3. If there is debris in the slide tracks, wipe it away using a paper towel. (Any graphite lubricant wiped away must be replaced - See steps 4 through 7.
4. Shake the graphite lubricant before opening it. Starting with the left (front and back) slide mechanism of the rack, place four (4) small drops of lubricant on the two (2) bottom tracks of the slide close to the bearing carriers.

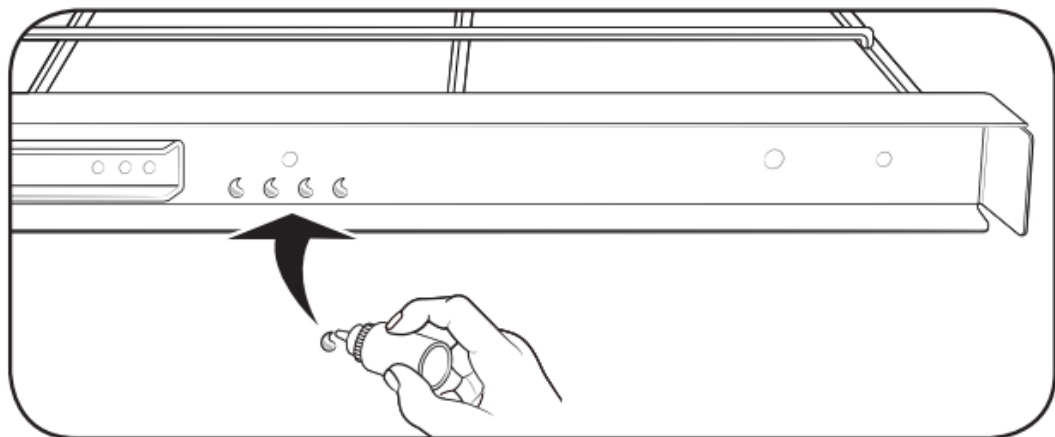
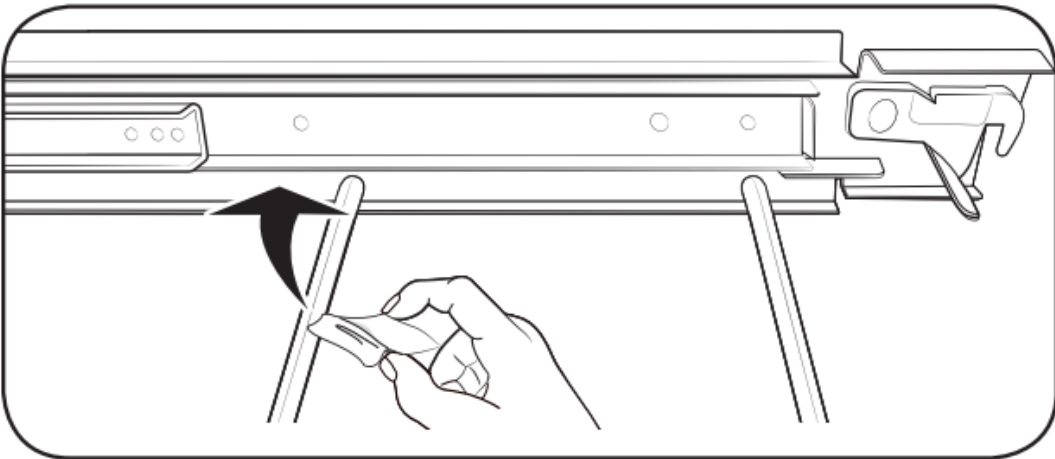
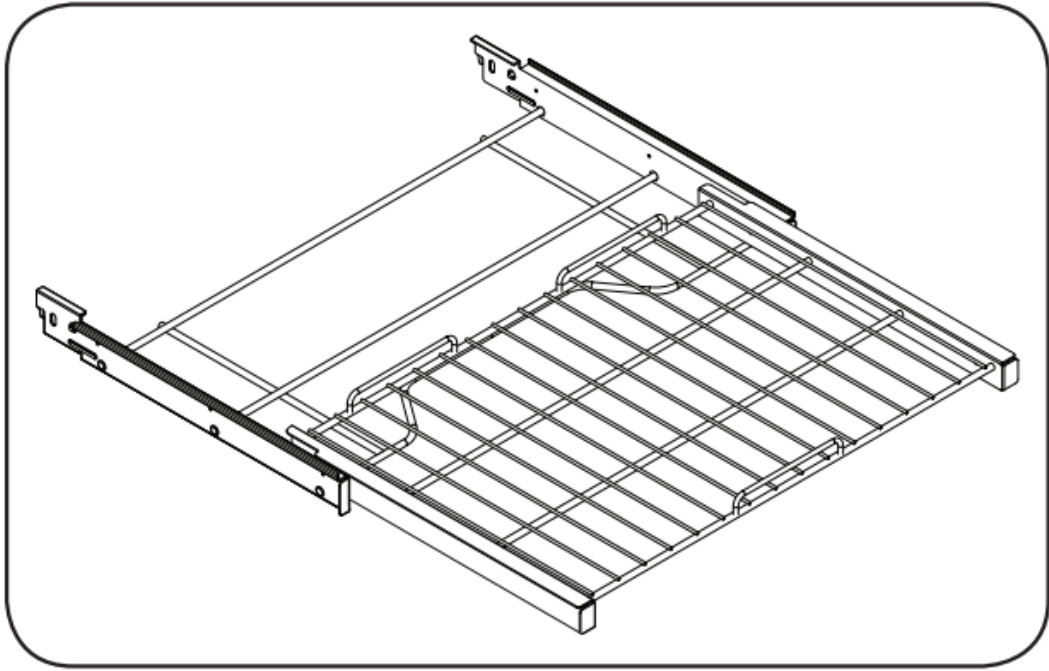

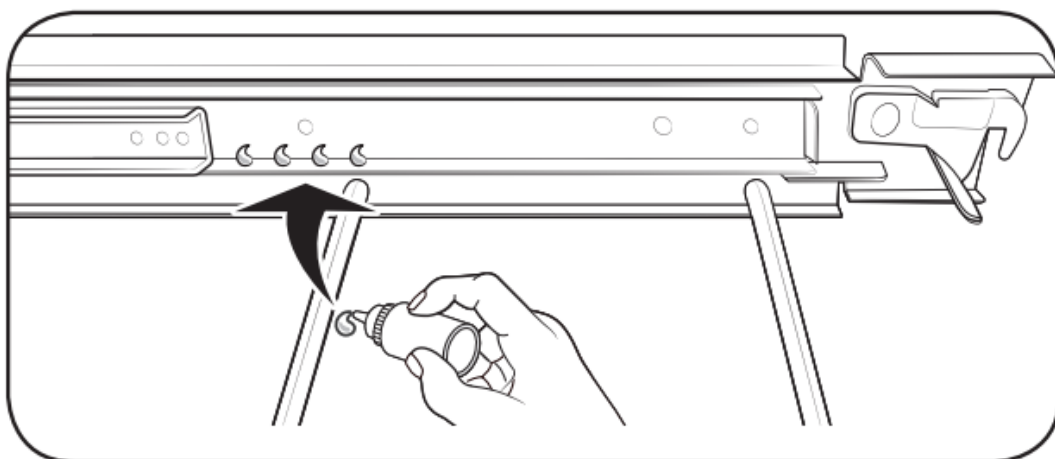

5. Repeat for the right (front and back) slide mechanism of the rack.
6. Open and close the rack several times to distribute the lubricant.
7. Replace the cap on the lubricant and shake it again. Turn the rack over and repeat steps 3, 4, 5, and 6.
8. Close the rack, turn the rack rightside-up, and then place in oven. See Installing the Gliding rack on page 39.

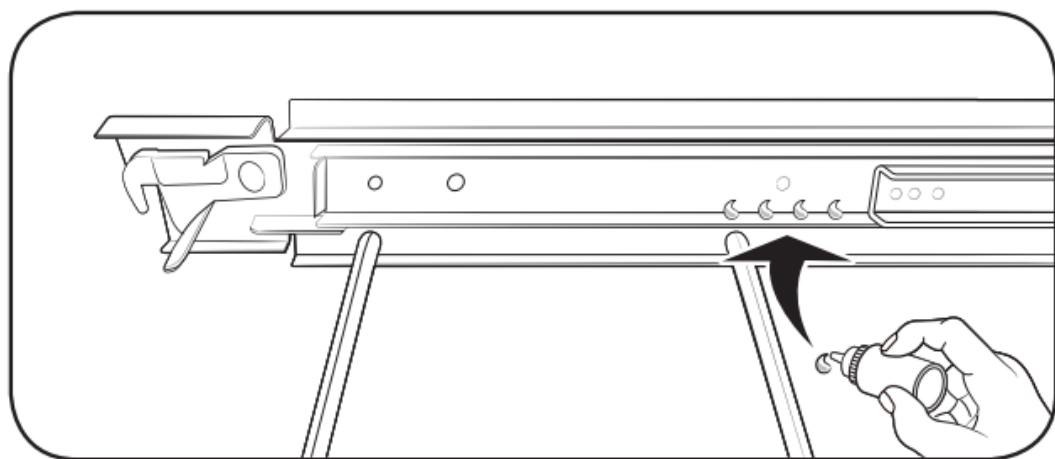

Oven door

- Use soap and water to thoroughly clean the top, sides, and front of the oven door. Rinse well. You may use a glass cleaner on the outside glass of the oven door. DO NOT immerse the door in water. DO NOT spray or allow water or the glass cleaner to enter the door vents. DO NOT use oven cleaners, cleaning powders, or any harsh abrasive cleaning materials on the outside of the oven door.
- DO NOT clean the oven door gasket. The oven door gasket is made of a woven material which is essential for a good seal. Care should be taken not to rub, damage, or remove this gasket.

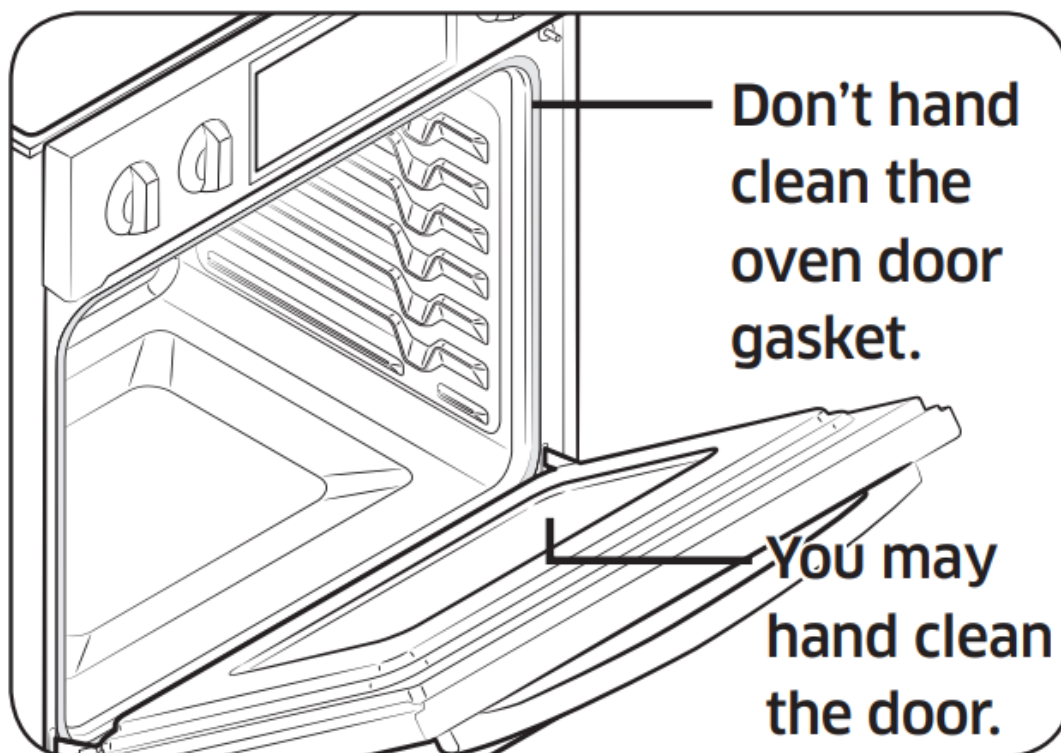

Removing the oven doors

1. Prior to removing the oven door, prepare a surface where you will place it. This surface should be flat and covered with a soft blanket. You can also use the corner posts from your packaging material.
2. Remove the rubber cap(for upper oven door), and then disconnect the LED light's Wire Harness from the bottom right of the door.

NOTE If you are removing the upper door, you must open the lower door to access the wire harness.

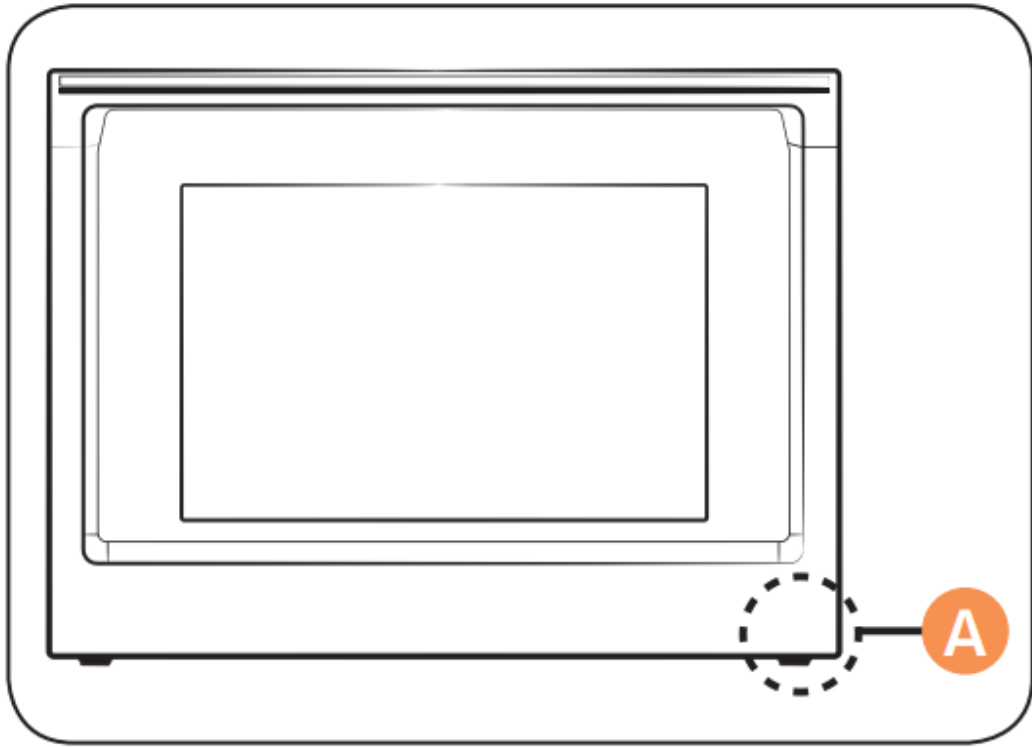

A. Wire Harness

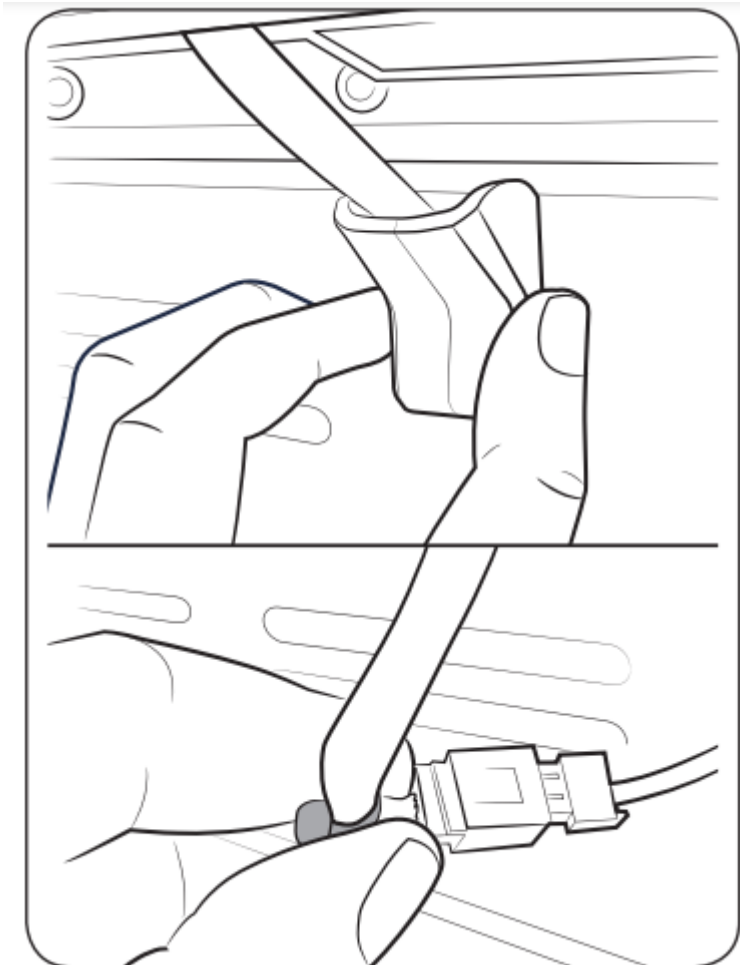

3. Open the oven door.
4. Locate the oven door hinge locks in both corners of the oven door, and then rotate the hinge locks toward the oven door to the unlocked position. If the door hinge lock is not rotated fully (see illustration B on the left for an example of full rotation), you will not be able to remove the door properly.
5. Partially close the door to engage the door latch locks. The door will stop at this point.
6. Using two hands, grasp the edges of the oven door. Lift and pull the oven door toward you and remove. You may need to gently shift the door from side to side as you pull.
7. Set the oven door aside on the prepared covered work surface with the oven door resting on its handle.

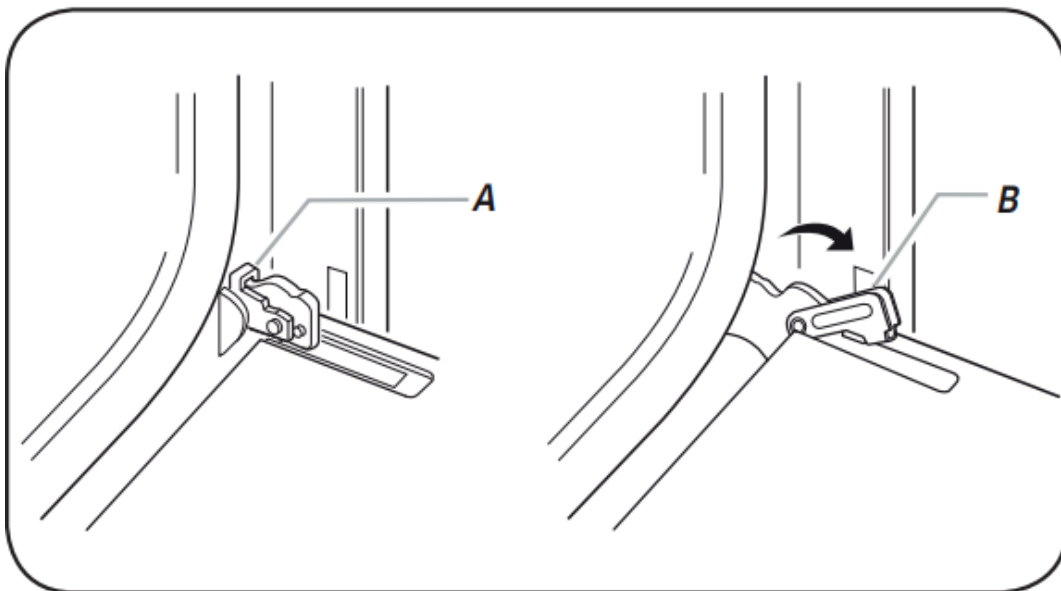

- A. Oven door hinge lock in locked position
- B. Oven door hinge lock in unlocked position

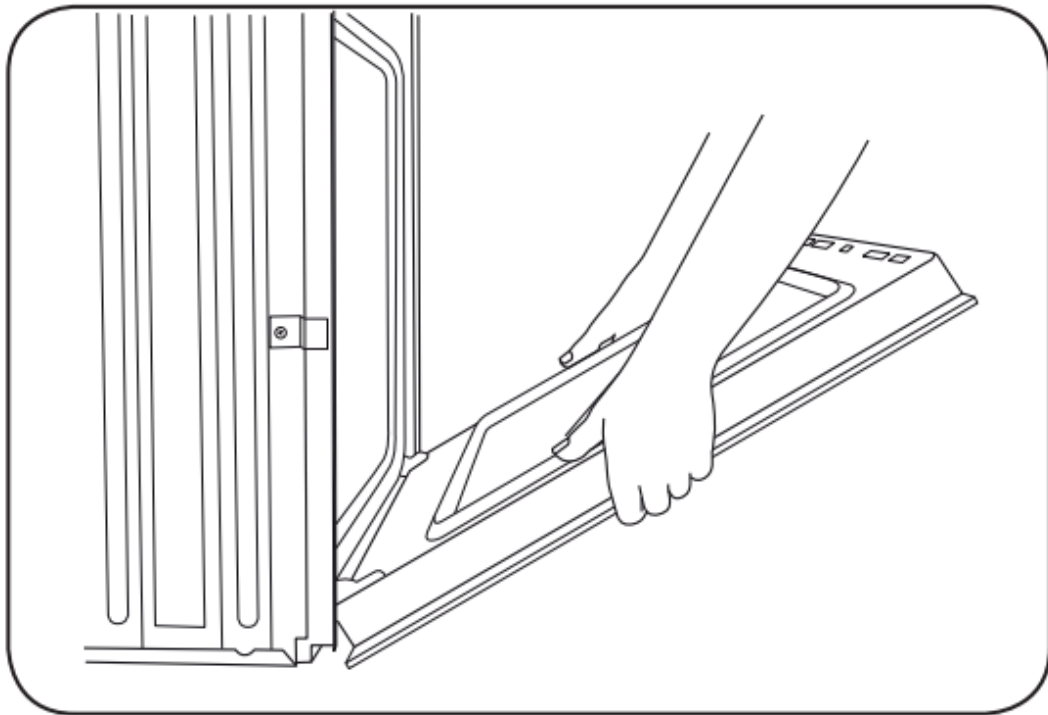
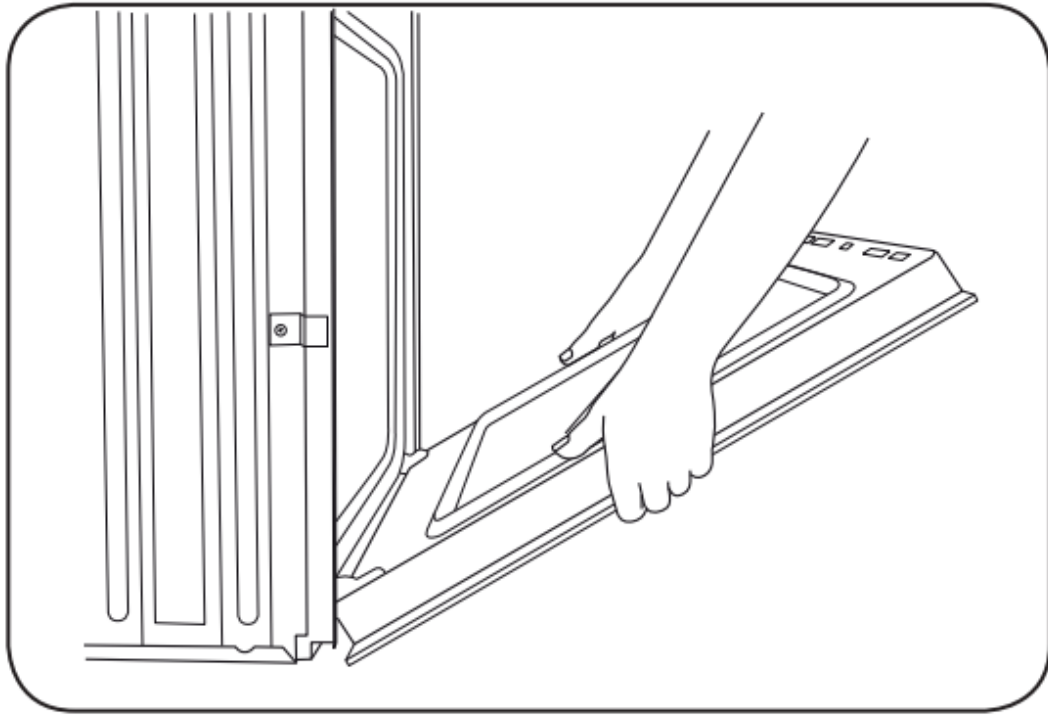

Replacing the oven doors

1. Using two hands, grasp the side edges of the door at the midpoint. Face the oven cavity.
2. Locate the slots on each side of the oven cavity for the door hinge locks.

3. Hold the door at a 45° angle, and then align the door hinges with the slots in the lower front of the oven cavity. Slowly insert the door, making sure you maintain the 45° angle. You will know the door is engaged in the slot when you feel a slight drop.

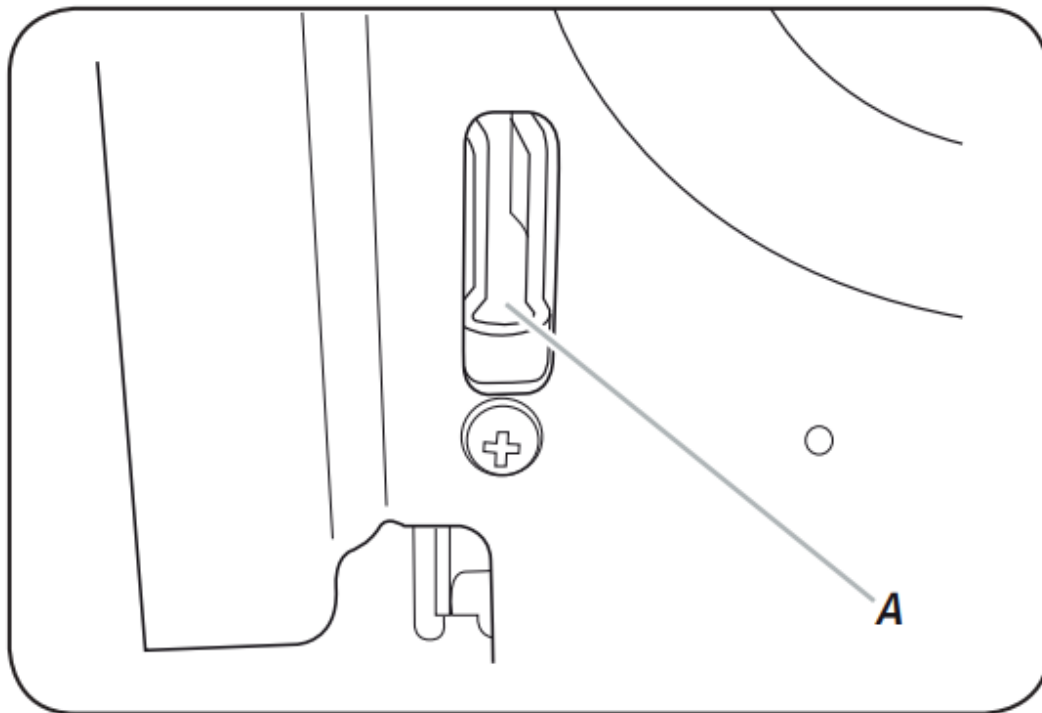

A. Slot in the oven cavity for the door hinge lock

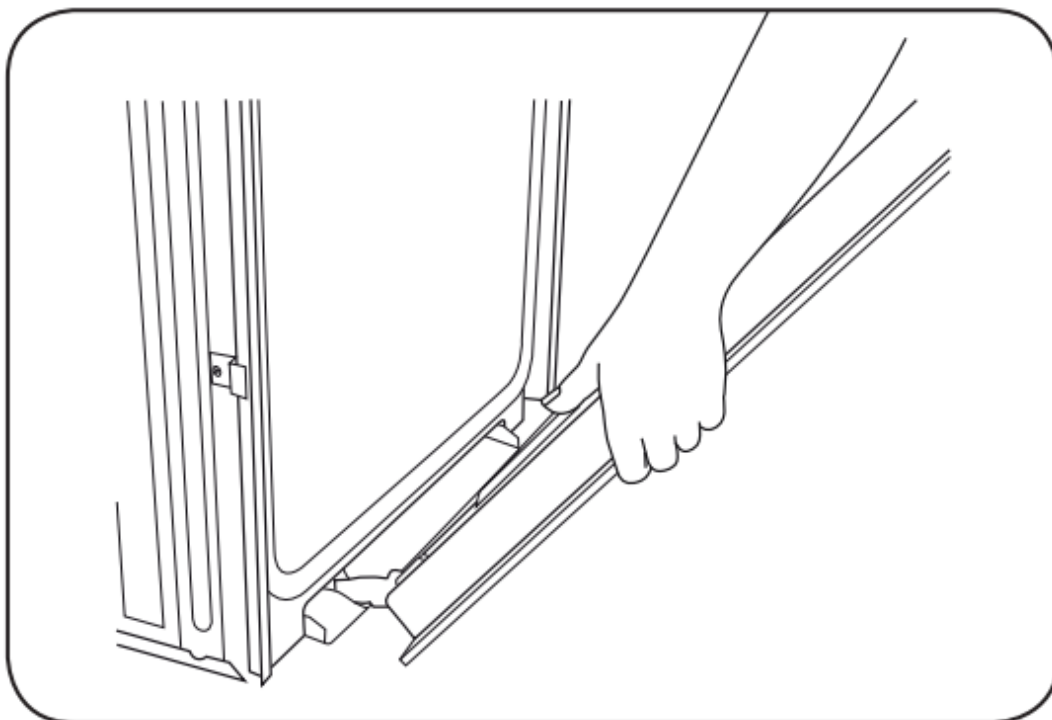

4. Lower the oven door to the fully open position. If the oven door does not open to a full 90°, repeat steps 1 through 3.

5. Locate the oven door hinge locks in the corners of the oven door, and rotate the hinge locks toward the oven cavity to the locked position. See Step 3 (illustration A) in the "Removing the oven doors" section for the proper locked position.
6. Close the oven door.
7. When the hinges are properly installed and the door is closed, there should be an even gap between the door and the control panel. If one side of the oven door is hanging lower than the other, the hinge on that side is not properly installed.
8. Reconnect the LED light's Wire Harness and re-insert the rubber.

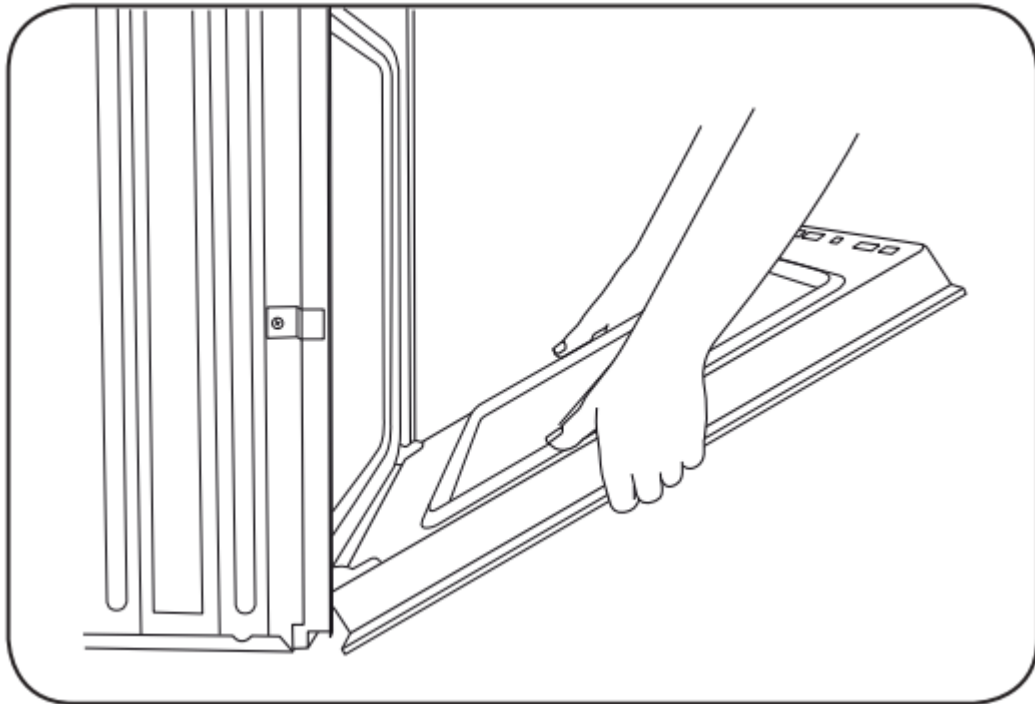

Changing the oven light

The oven light is a standard 40-watt appliance halogen bulb. It comes on when the

oven door is open. When the oven door is closed, touch Lamp  to turn the light on or off. It will not work during a self-cleaning or Hybrid cleaning cycle.

1. To change the halogen bulb, you must tilt the broil heater down. To do this, turn the circular nut on the support counterclockwise while holding the broil heater. The broil heater should loosen and tilt down.

Important: The broil heater is not a removable part. Do not force the broil heater down. Do not let it drop down.

2. Remove the glass cover.
3. Remove the halogen bulb cover.
4. Replace the halogen bulb.

5. When done, replace the glass cover, and then follow Step 1 above in the reverse order to return the broiler to its correct position.

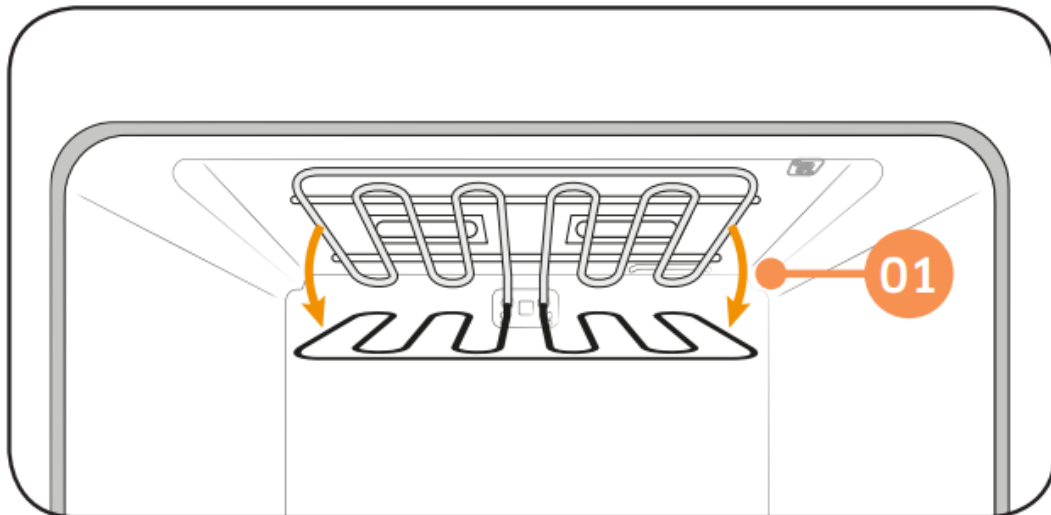
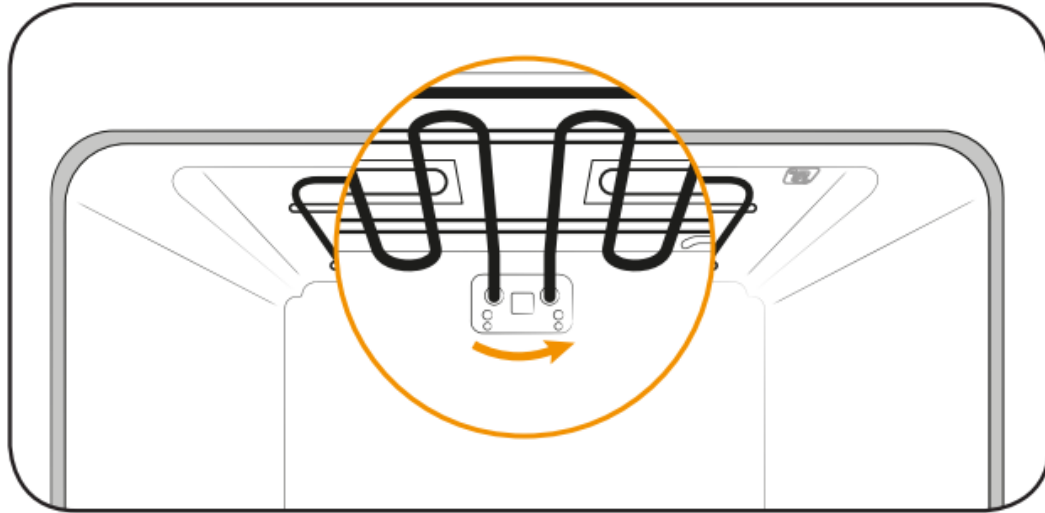

Troubleshooting

CONTROL DISPLAY

Problem	Possible cause	Solution
The display goes blank.	A fuse in your home may be blown or the circuit breaker tripped.	Replace the fuse or reset the circuit breaker.
The buttons cannot be pressed properly	<ul style="list-style-type: none"> • There is foreign matter caught between the buttons • Touch model: There is moisture on the exterior • The lock function is set 	<ul style="list-style-type: none"> • Remove the foreign matter and try again. • Remove the moisture and try again. • Check whether the lock function is set.

OVEN



Problem	Possible cause	Solution
The oven will not turn on	The oven is not completely plugged into the electrical outlet.	Make sure the electrical plug is inserted into a live, properly grounded outlet.
	A fuse in your home may be blown or a circuit breaker may have tripped.	Replace the fuse or reset the circuit breaker
	The oven controls have been set improperly.	See the Operating the oven section starting on page 20
	The oven is too hot	Allow the oven to cool.
	Incomplete service wiring	Call for service
	Power outage.	Check to see if the house lights will turn on. If necessary, call your local electric company for service.
The oven light will not turn on	The light is loose or defective	<ul style="list-style-type: none"> • Tighten or replace the lamp. • Call for service if the door light does not turn on.
	The switch operating the light is broken.	Call for service
	The oven controls have not been set properly.	See the Operating the oven section starting on page 20
	The meat has been placed too close to the element.	Reposition the rack to provide proper clearance between the meat and the element. Preheat the broil element for searing.
	The meat has not been properly prepared.	Remove excess fat from the meat. Cut away fatty edges that may curl, leaving the lean intact.

	Grease has built up on oven surfaces.	Regular cleaning is necessary when broiling frequently
Food does not bake or roast properly	The oven controls have not been set correctly	See the Operating the oven section starting on page 20.
	The oven rack has been positioned incorrectly or is not level.	See the Using the oven racks section on page 37.
	The oven thermistor needs to be adjusted.	See Temp adjust in the Settings section on page 48.
	The serving size may not be appropriate.	Refer to the Broiling recommendation guide for serving sizes on page 30, and then try again.
	The rack has not been properly positioned.	See the Broiling recommendation guide on page 30.
	The cookware is not suited for broiling.	Use suitable cookware.
	In some areas, the power (voltage) may be low.	<ul style="list-style-type: none"> • Preheat the broil element for 10 minutes. • See the Broiling recommendation guide on page 30.
The oven temperature is too hot or too cold	The oven thermistor needs to be adjusted.	See Temp adjust in the Settings section on page 48.
There is water dripping.	You may see water or steam in some cases depending on the food you are cooking. This is not a product malfunction.	Let the oven cool and then wipe with a dry dish towel.
There is steam coming through the crack between the oven body and the door		

Water remains in the oven.		
I can hear water boiling during steam cooking.	Water is being heated by the steam heater.`	This is not a product malfunction.
The oven will not self-clean.	The oven temperature is too high to start a self-clean operation.	Allow the oven to cool and then reset the controls.
	The oven controls have been set incorrectly	See the Self Clean section on page 41.
	A self-cleaning cycle cannot be started if the oven lockout feature has been activated	Deactivate the oven lockout (see page 22).
Excessive smoking during a self-cleaning cycle.	There is excessive soiling in the oven.	Press OFF. Open the windows to rid the room of smoke. Wait until the self-cleaning cycle is cancelled. Wipe up the excessive soil and then start the self-cleaning cycle again.
The oven door will not open after a selfcleaning cycle	The oven is too hot.	Allow the oven to cool
The oven is not clean after a self-cleaning cycle.	The oven controls were not set correctly.	See the Self Clean section on page 41.
	The oven was heavily soiled.	Wipe up heavy spillovers before starting the selfcleaning cycle. Heavily soiled ovens may need to be selfcleaned again or for a longer period of time.
Steam is coming out of the vent.	When using the convection feature, it is normal to see steam coming out of the oven vent.	This is normal operation and not a system failure. Use the oven as usual.

	As the number of racks or amount of food being cooked increases, the amount of visible steam will increase	
A burning or oily odor is coming from the vent.	This is normal for a new oven and will disappear in time.	<ul style="list-style-type: none"> • To speed the process, set a self-cleaning cycle for a minimum of 3 hours. • See the Self Clean section on page 41.
Strong odor.	An odor coming from the insulation around the inside of the oven is normal for the first few times the oven is used.	Operate the oven empty on the bake setting at 400 °F for 1 hour.
Fan noise.	A convection fan may automatically turn on and off.	This is not a system failure but normal operation.
The oven racks are difficult to slide.	The shiny, silver-colored racks were cleaned in a selfcleaning cycle.	Apply a small amount of vegetable oil to a paper towel, and then wipe the edges of the oven racks with the paper towel.
The oven door is locked.	The circuit breaker has been tripped or there was a power failure while the oven door was locked.	Activate Control Lockout, and then unlock the control. See the Control Lockout section on page 22.

Information codes

OVEN

Displayed Code	Possible cause	Solution
C-d0	This code occurs if the control key is short for 1 minute.	Clean the buttons and make sure there is no water on/ around them. Turn off the oven and try again. If the problem continues, contact a local Samsung service center.
C-d1	This code occurs if the door lock is mispositioned.	Press OFF, and then restart the oven. If the problem persists, disconnect all power to the oven for at least 30 seconds and then reconnect the power. If this does not solve the problem, call for service.
C-F0	This code occurs if communication between the Main and Sub PBA is interrupted	
C-F2	This code occurs if communication between the Main and Touch is interrupted.	
C-20	The oven sensor is open when the oven is operating	
	The oven sensor is short when the oven is operating	
C-21	This code occurs if the internal temperature rises abnormally high.	
C-23	The temp probe sensor is short when the oven is operating.	Press OFF, and then restart the oven. If the problem persists, disconnect all power to the oven for at least 30 seconds and then reconnect the power. If this does not solve the problem, call for service.
C-30	The PCB sensor is open when the oven is operating.	

	The PCB sensor is short when the oven is operating.	
C-31	This code occurs if the PCB temperature rises abnormally high.	Call for service
-dC-	This code appears if the divider is inserted or removed while the oven is operating.	Make sure the divider is inserted properly, and then restart the oven. If the problem persists, disconnect all power to the oven for at least 30 seconds and then reconnect the power. If this does not solve the problem, call for service.
C-70	The steam sensor is open when the oven is operating	Press OFF, and then restart the oven. If the problem persists, disconnect all power to the oven for at least 30 seconds and then reconnect the power. If does not solve the problem, call the service.
	The steam sensor is short when the oven is operating	
C-72	There are drain system-related problems.	
C-A2	The cooling motor is operating abnormally.	Call for service.

Warning

This content is compiled from multiple sources and is provided for reference purposes only. It may not be complete or fully applicable to all situations. If you are unable to resolve your issue, please contact the product manufacturer or an authorized service provider for official support.