

## PRODUCT FEATURES

This revolutionary Mini Robotic Vacuum Cleaner is equipped with functions suitable for cleaning up floor surfaces of home and office, such as wood, tile, and linoleum. The Mini Robotic Vacuum Cleaner is definitely a good household helper.

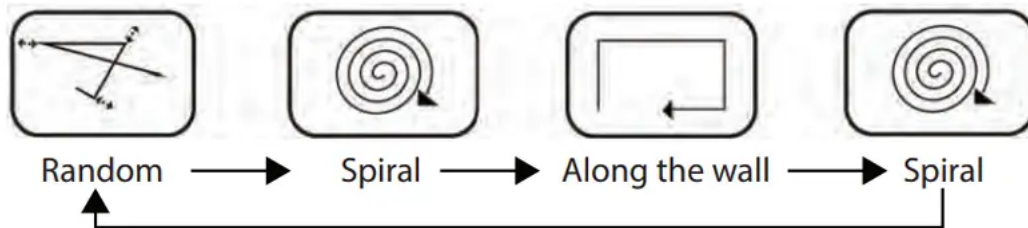

## MAIN BODY AND ACCESSORIES



Main body x 1

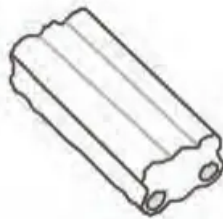

Rechargeable battery x 1

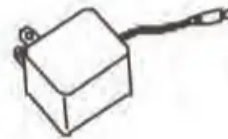

Adapter x 1



Filter x 1



User Manual x 1



Side brush x 2

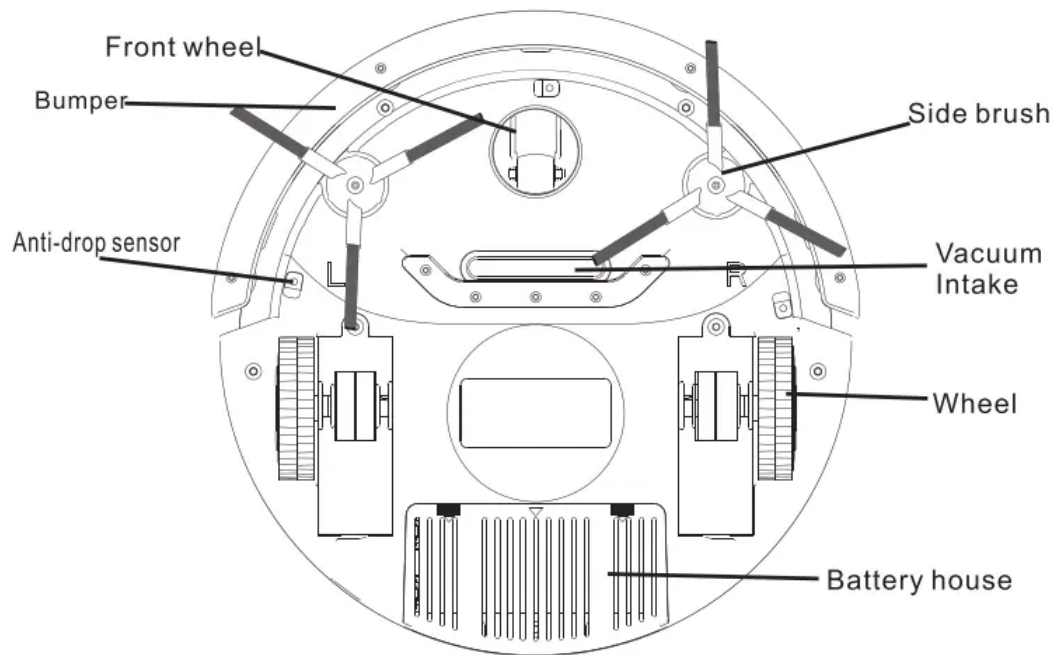
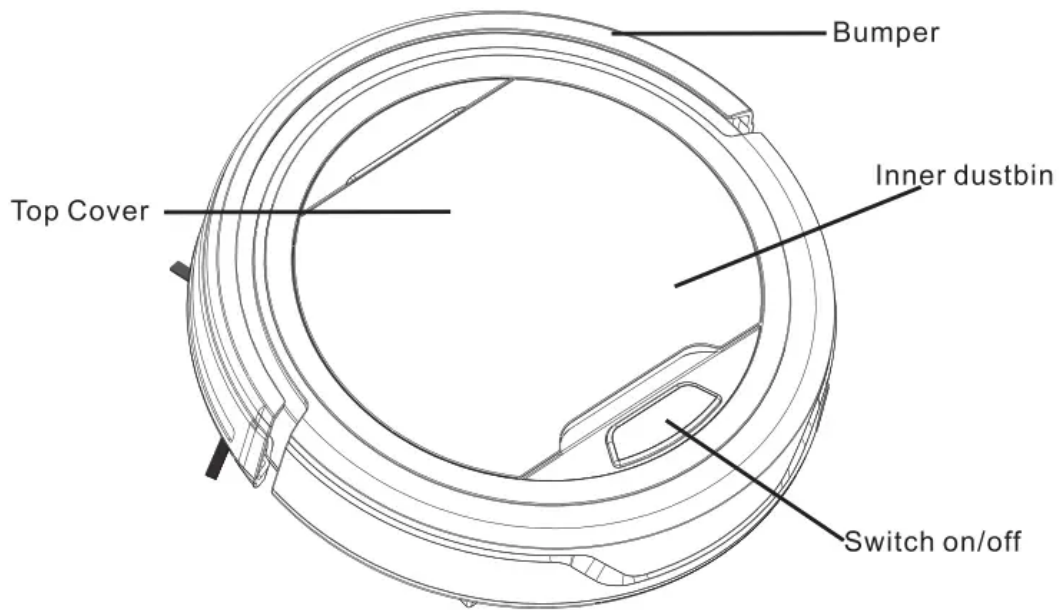

## PRODUCT FEATURES

1. Before installing or removing the battery, the product must be disconnected from the power source.
2. Open the battery cover.
3. Insert the battery into the battery cabinet and close the cover. Make sure the cover clips well located in its position.

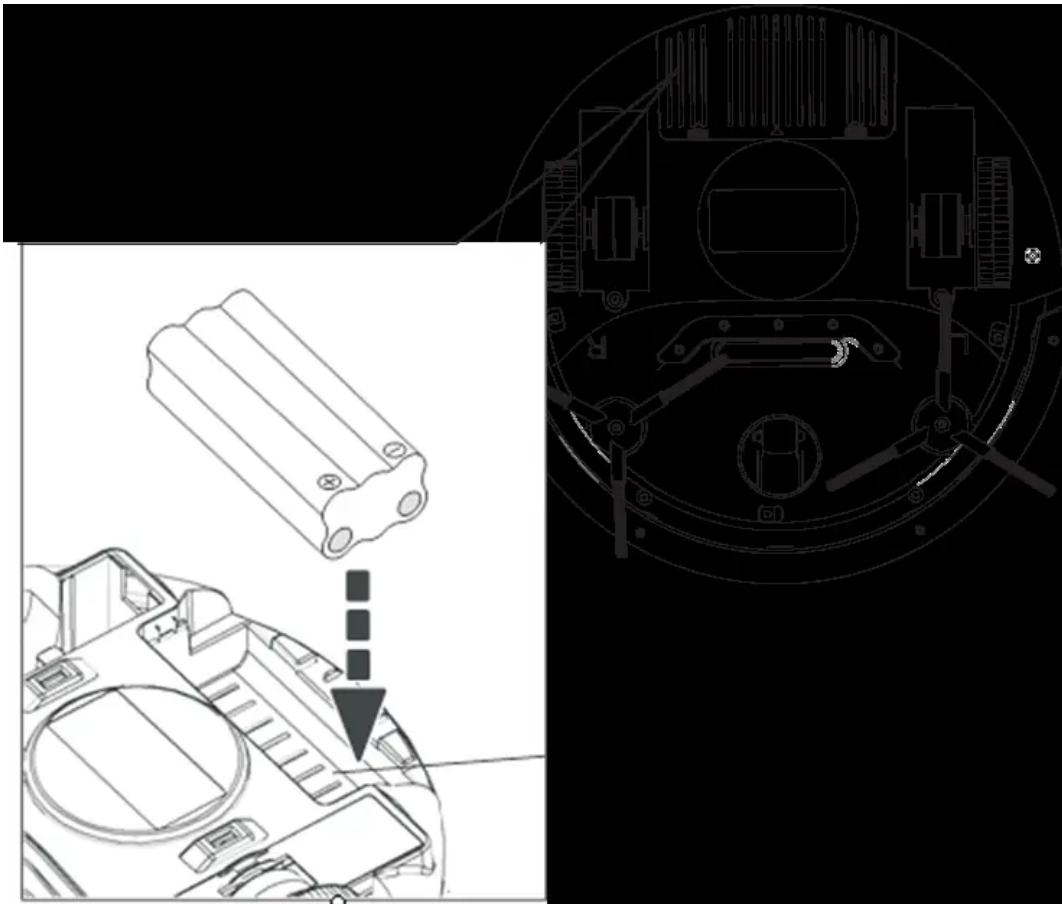

## RECHARGING BATTERY

1. Before charging, make sure the battery is correctly installed.
2. **The procedure of charging the product is as follows:** firstly, connect the adapter output into the DC jack, and then plug into power socket of the other end, a blue light will flash.
3. After fully charged, the indicator light will turn to solid blue light.
4. When the product runs out of power, LED indicator will turn red, which prompts the user to charge the product.
5. To ensure the best performance and lift span of the battery, please charge the product for at least 4 hours continuously. After fully charged for 4 hrs, indicator light will turn to solid blue light. The product can do cleaning after 4 hours charging.

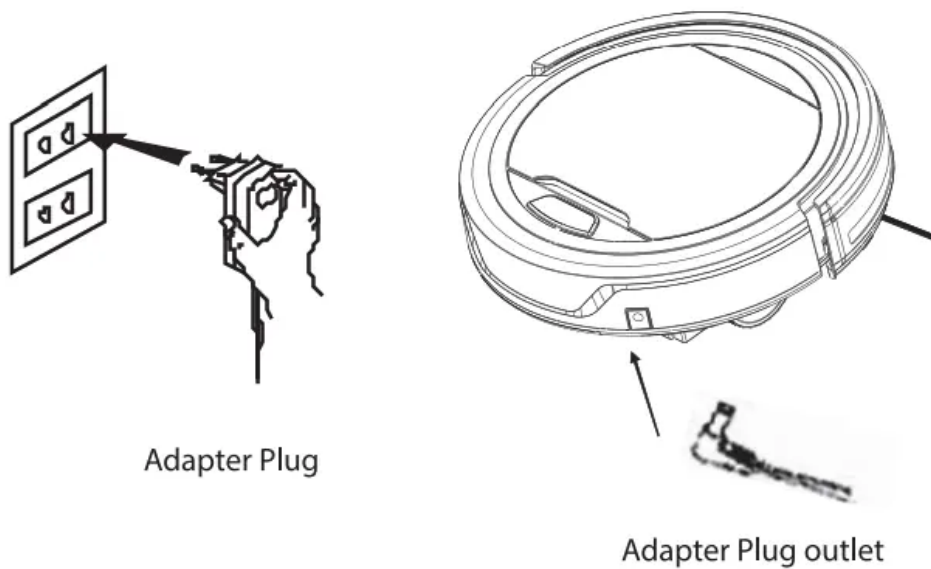

## GENERAL OPERATION

### Starting Operation

1. For first use, take out the insulating strip in battery cabinet as shown in figure below, and then put back the battery cover.
2. Place the product in a room with much free space, and then power it on to do cleaning work.
3. When the product runs out of power, the LED indicator in the illumination ring will turn red which the product will stop working.

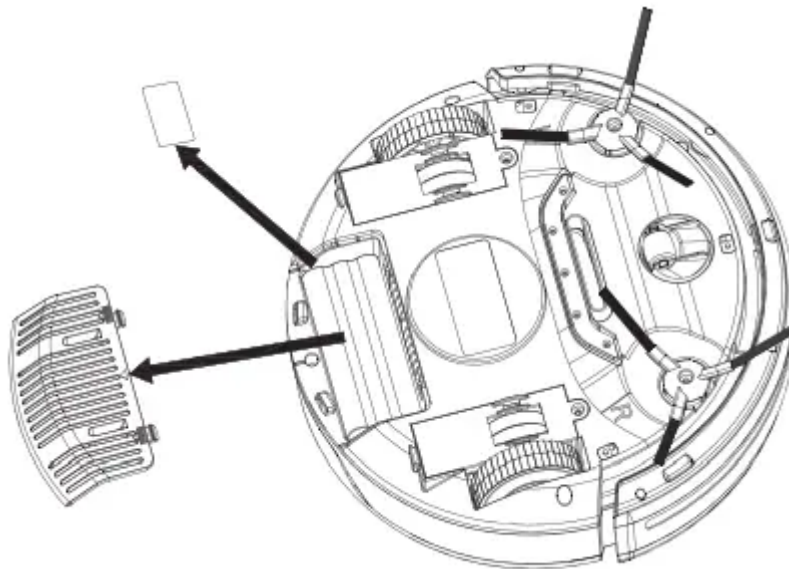

### Note:

\* This product is not suitable for long-pile carpets.

## SIDE BRUSH INSTALLATION

Put the L side brush at L place and R side brush at R place on the bottom and then push to fix it and vice versa—to pull up, side brush will be taken out.

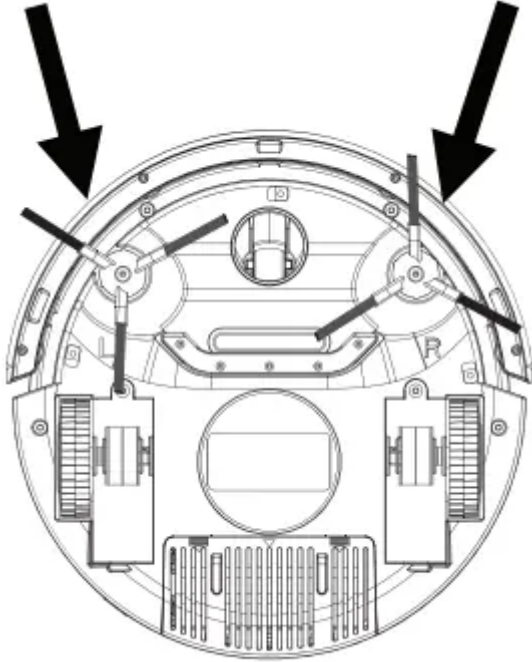

## CLEAN AND MAINTENANCE

### Cleaning Dust Bin

1. Open the upper cover by lifting the lid near the power on/off button.
2. Put your finger into the dust bin groove and grip to take it out.

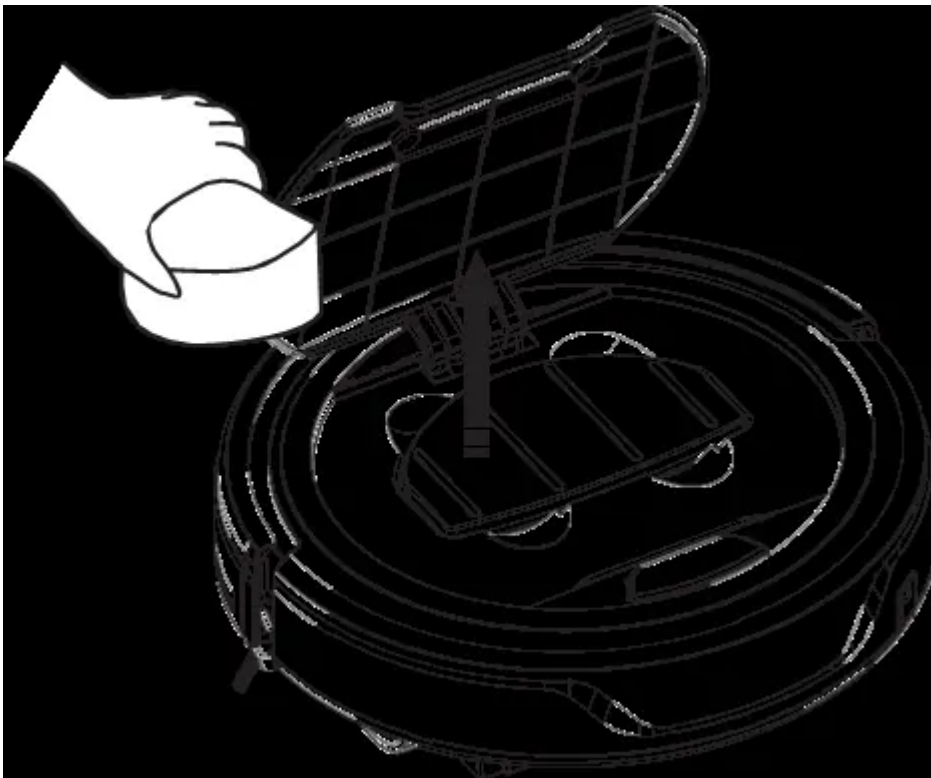

3. Open the dust bin lid
4. Take out the inner filter
5. Empty the dirt in the dust bin.

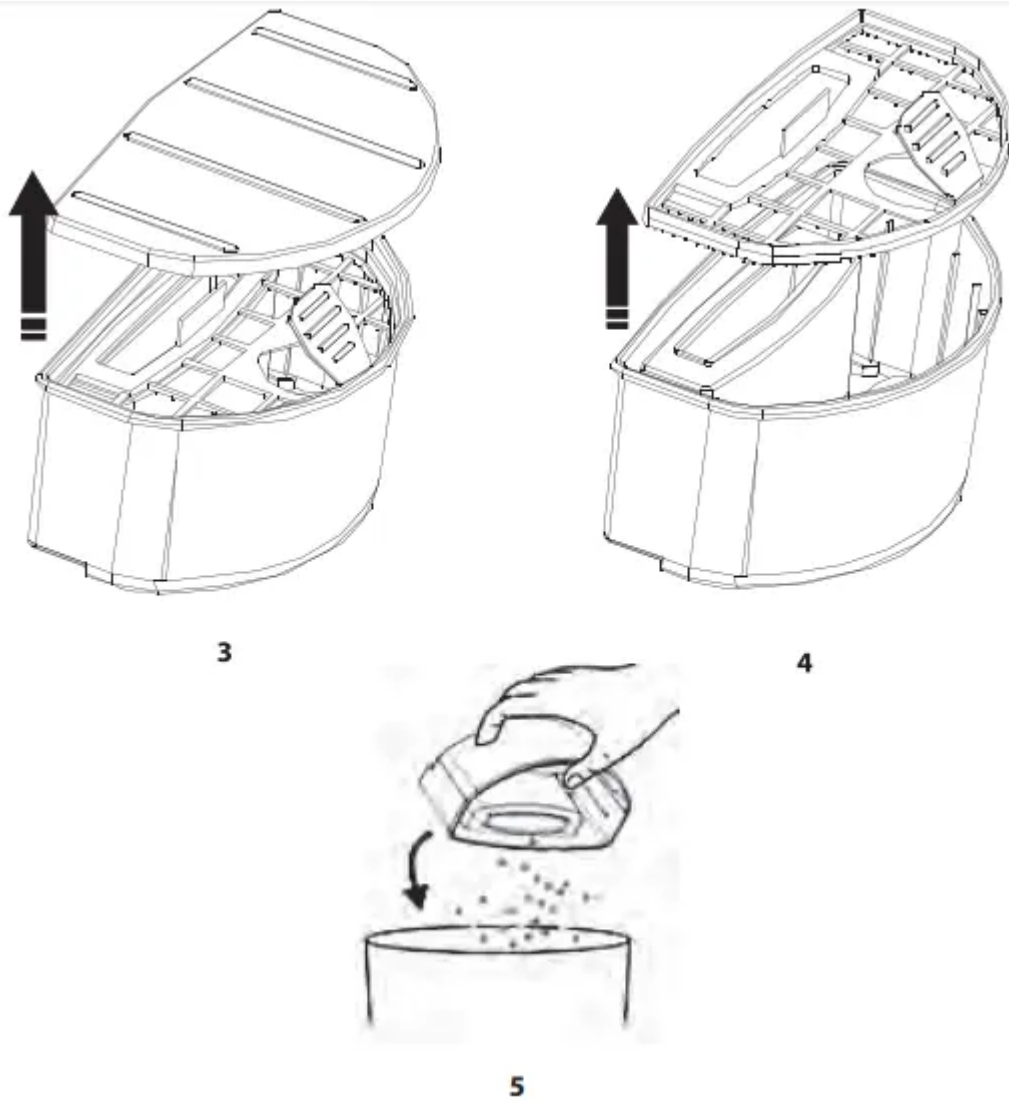

### Cleaning Dust Bin

1. Rinse the dust bin with tap water. Do not wash it in washing machine, dish-washing machine or other machine.
2. Periodically clean the filter with a soft bristle brush.
3. Reinstall the filter and the dust bin lid once they get dried.
4. Put back the dust bin into the cleaner.

#### NOTE:

Before putting back the dust bin, please make sure the PE pad (function as non-return valve) in the dust bin is well attached. Recheck the filter also before operating the product. Using product without filter might cause malfunction.

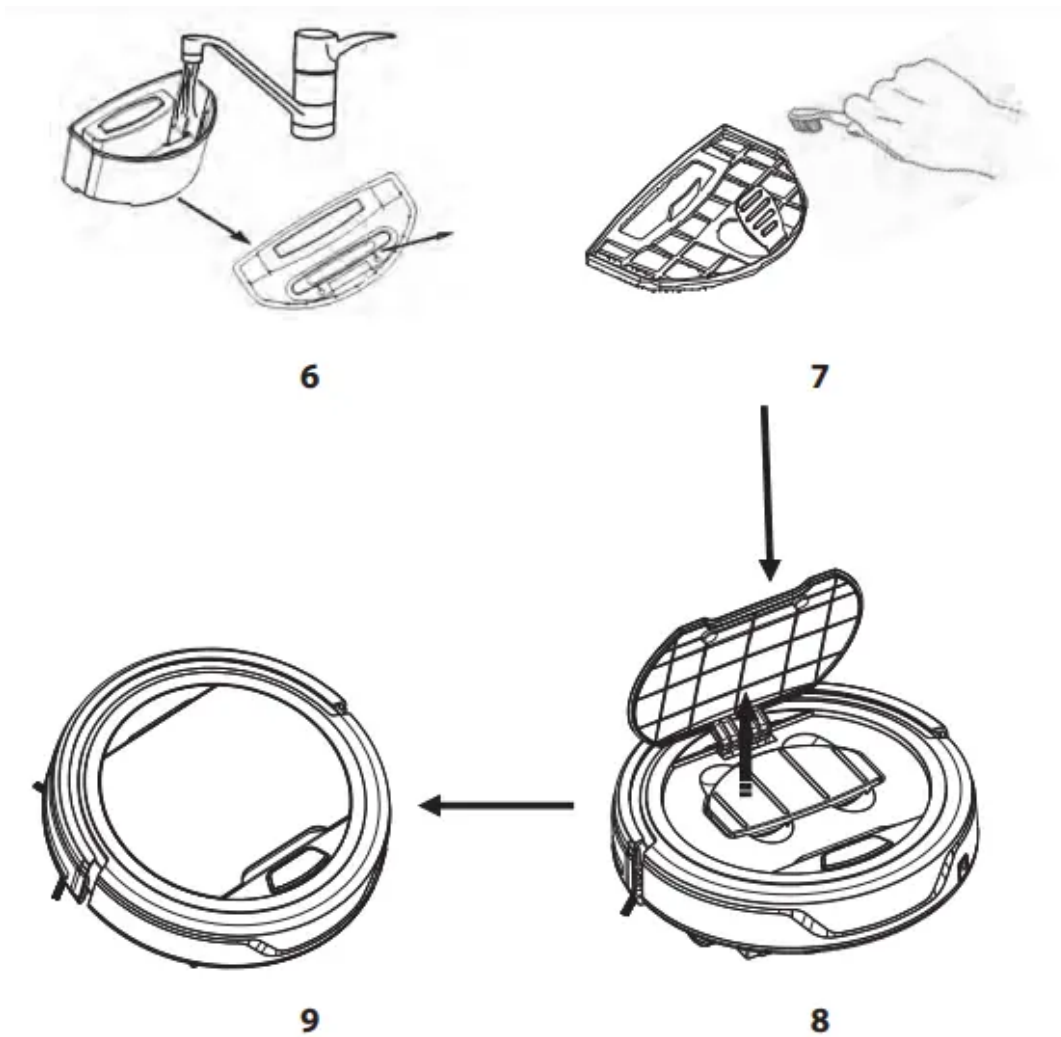

## Cleaning intake

After repeated use for some time, dirt and dust might accumulate around the intake of the product, to ensure its best cleaning efficiency and constant airflow it should be cleaned periodically.

- 1.Remove the external power source.
- 2.Clean up the dirt and dust at the intake.

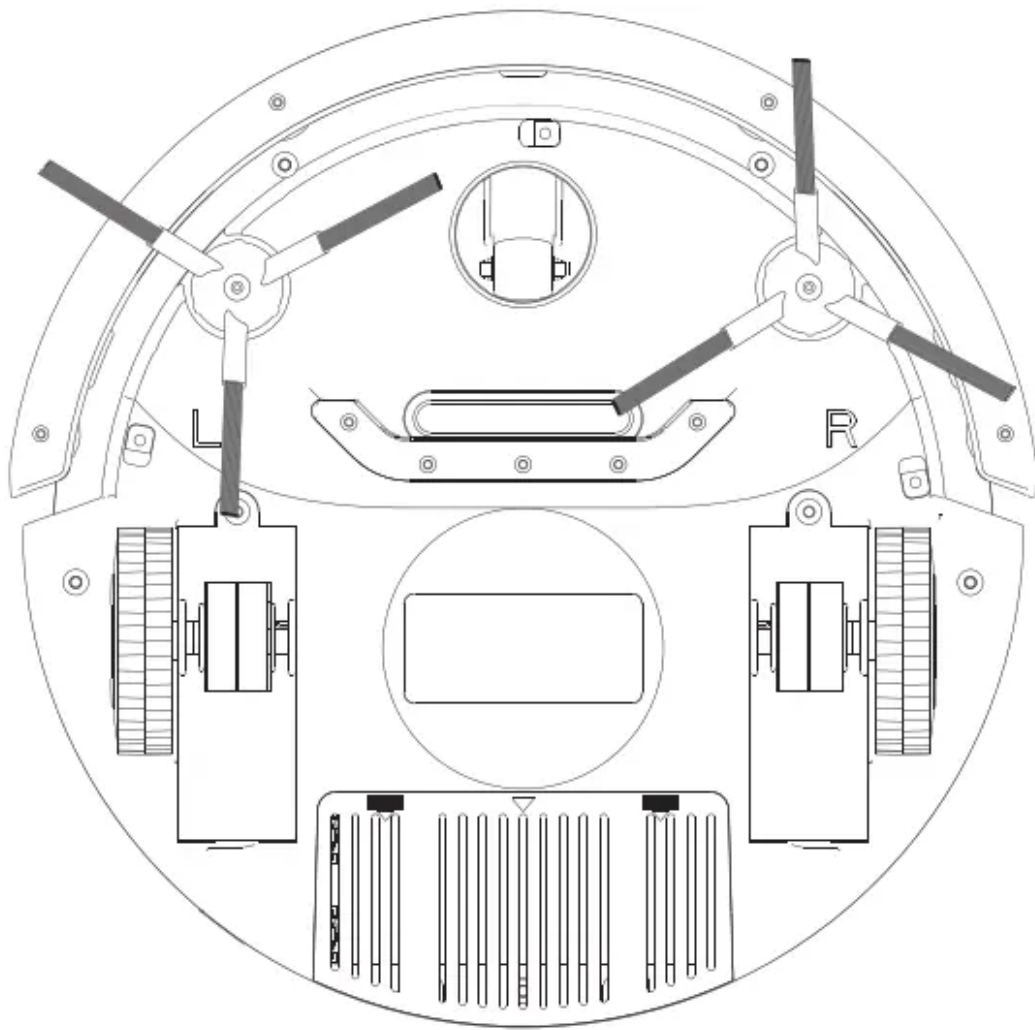

# TROUBLESHOOTING



	<b>Problem</b>	<b>Possible Cause</b>	<b>Solution</b>
<b>1</b>	Red LED stays after power on	1.Battery Low condition 2.Main body is picked up	1.Recharge the battery 2.Replace the robot on the floor
<b>2</b>	Vacuum on but can not collect dirt and hair	1.The dust bin is full 2.The filter is not installed correctly	1.Clean the dust bin 2.Re-install the filter correctly
<b>3</b>	The product is moving backwards after being started	1.The product is on dark colored floor 2.Anti-drop sensor light was covered	1.Put the robot on light color floor. 2.Clean anti-drop sensor light.
<b>4</b>	LED indicators flash in blue after 4hrs charging	Power supply might been cut off during charging	The robot can be operated if the battery has been fully charged for 4hrs
<b>5</b>	The side brushes crooked, not good to sweep	Being used for a long time	If it becomes crooked, please scald it in hot water to recover it to its original shape
<b>6</b>	The product won't start	1.Battery is not installed properly 2.Battery low 3.The robot is under protection status	1.To install the battery correctly 2.To have the battery fully charged (turn off the cleaner first) 3.To re-set the robot
<b>7</b>	The product circles around only, cannot go straight	One of the wires of the wheels might be loosened	1.Open the wheel cover and connect the loosen wire properly 2.Send the robot to seller for repairing

# SAFETY INSTRUCTIONS

Before using this product, please read the safety instructions and follow all normal safety precautions.

1. Read this user manual thoroughly and carefully before using this product
2. Keep this manual in your sight.
3. Any operation opposite to descriptions in this user manual may lead to harm to human or this product.

## Safety Instructions

1. Only use the product indoors, do not use it outdoors.
2. Before starting the product, make sure the dust bin filter is properly installed.
3. Do not use this product in wet or moist environment (any environment with liquid), e.g. bathroom or laundry.
4. Before use, collect the floor environment (remove all the fragile objects and cords, clothing, papers, loose cables, as well as making sure to lift curtains and drapes off the floor to avoid any possible accidents. In case that a loose cable is tangled with the product, the cable might move around with the product as it works and topple down the table, chairs, or cabinet and might cause hurt or property damage.)
5. Do not sit on top of this product or attach an object on the top of it. Beware of children or pets while the product is in operation
6. Do not make this product close to cigarette, lighter, match or any flammable
7. Never use the product to clean up combustible or highly volatile liquids such as gasoline.
8. While the product is in operation, make sure all doors leading outside are closed.
9. In case that the product is malfunctioned or damaged by external force, please contact the seller before repairing.
10. Before charging, check whether adapter and outlet are properly connected.
11. Use this product in temperature from 0°C to 40 (centigrade degree) and do not place this product in high-temperature environment or under baking sunlight for a long time.
12. The appliance is not to be used by person (including children) with reduced physical, sensory or mental capabilities, or persons lack of experience and knowledge, unless they have been given supervision or instruction.
13. Children being supervised do not play with the appliance.

## Battery and Recharging Instructions

- 1.The battery is rechargeable, please use the voltage and current specified on the packing. If you are not sure of the voltage and current of your house, please contact the seller or local power company or a licensed electrician. (Only use battery pack which provided by manufacturer or specified by manufacturer, please check the polarity before installing the battery. Battery voltage: 14.4VDC, working current: 850mA)
- 2.Only use the original battery and power adapter of the product for charging.
- 3.Charging adaptor is for indoors use only.
- 4.Do not recharge the product if the battery cord or plug is damaged.
- 5.Never touch the charger, plug or cable with damp hands.
- 6.Before cleaning the product, unplug the adaptor, switch off the unit and take out the battery.
- 7.Please take out the battery when it is not in use for a long time.
- 8.The battery must be removed from the product before it is scrapped.
- 9.The product must be disconnected from the power source when removing the battery. The battery is to be disposed of safely.

### Warning

This content is compiled from multiple sources and is provided for reference purposes only. It may not be complete or fully applicable to all situations. If you are unable to resolve your issue, please contact the product manufacturer or an authorized service provider for official support.